

DE LA RECHERCHE À L'INDUSTRIE



Correlations between Tunneling Spectroscopy and SRF cavity performances

Thomas Proslie

TTC – CERN - 05/02/220

Team:

Technician: A. Four, E. Fayet, G. Jullien, C. Servouin

Scientist: S. Berry, C. Antoine, E. Cenni, G. Devanz, F. Eozenou, **T. Proslie**

Ph.D.: Sarra Bira (IPNO/CEA), Y. Kalboussi (CEA)

Internship: R. Dubroeuq, S. Habhab

Collaborations:

KEK: T. Saeki, T. Kubo, Marui. (thin films, theory, electropolishing)

IPNO: D. Longuevergne, M. Fouaidy, T. Pépin-donat

HZB: O. Kugeler (characterization, thin films)

DESY: M. Wenskat (characterization, thin films)

CERN: G. Rosaz, S. Calatroni (thin films)

STFC: R. Valizadeh (thin films, Nb₃Sn)

INFN: C. Pira (thin films)

JLAB: A-M. Valente, G. Ciovati, D. Patshupati (Bulk Nb, thin films)

FNAL: S. Posen, A. Romanenko, A. Grassellino, M. Chechin (Bulk Nb, Nb₃Sn)

ANL: A. Glatz – Theory (theory simulations)

IIT: J. Zasadzinski

TRIUMPH: T. Junginger (characterization)

Cornell: D. Hall, M. Liepe (Nb₃Sn)

Correlations between Tunneling Spectroscopy and SRF cavity performances

- Point Contact Tunneling spectroscopy
- Bulk Nb treatments
- Nb₃Sn/Nb
- Summary and future

Correlations between Tunneling Spectroscopy and SRF cavity performances

- Point Contact Tunneling spectroscopy
- Bulk Nb treatments
- Nb₃Sn/Nb
- Summary and future

Tunneling spectroscopy: what do we measure and why?

principle

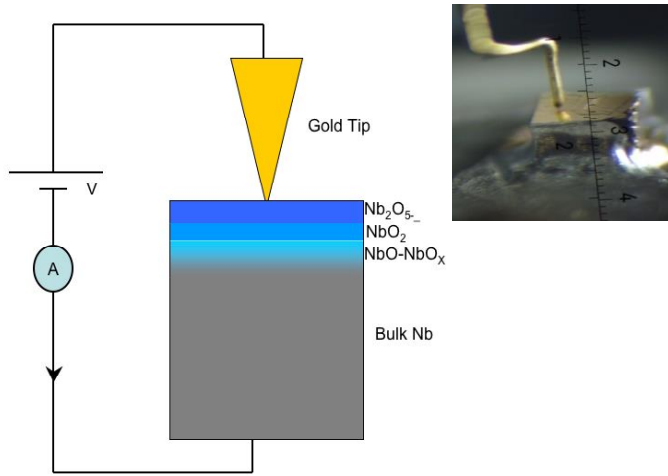

measure

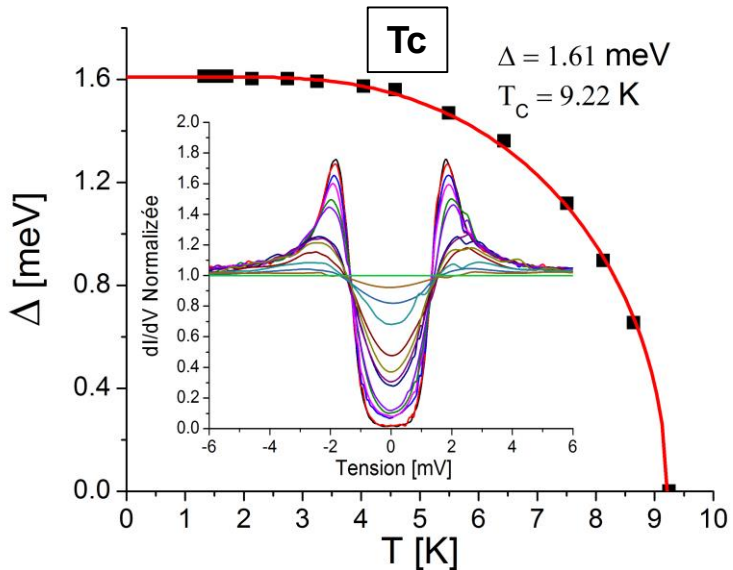
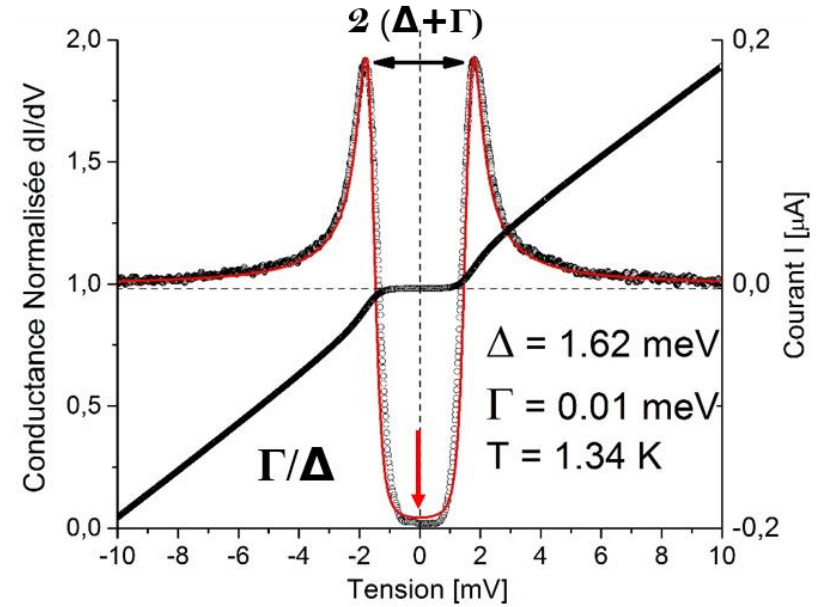

- Measure the fundamental superconducting parameters:
 Δ , T_C , H_{C2}
- Measure non-ideal signature: Γ .
- Shape of the DOS give clues to microscopic origins:
Proximity effect, magnetic impurities, deleterious phases.
- Direct correlation to **SRF cavity performances.**
- Cartography.

The Point Contact system at CEA

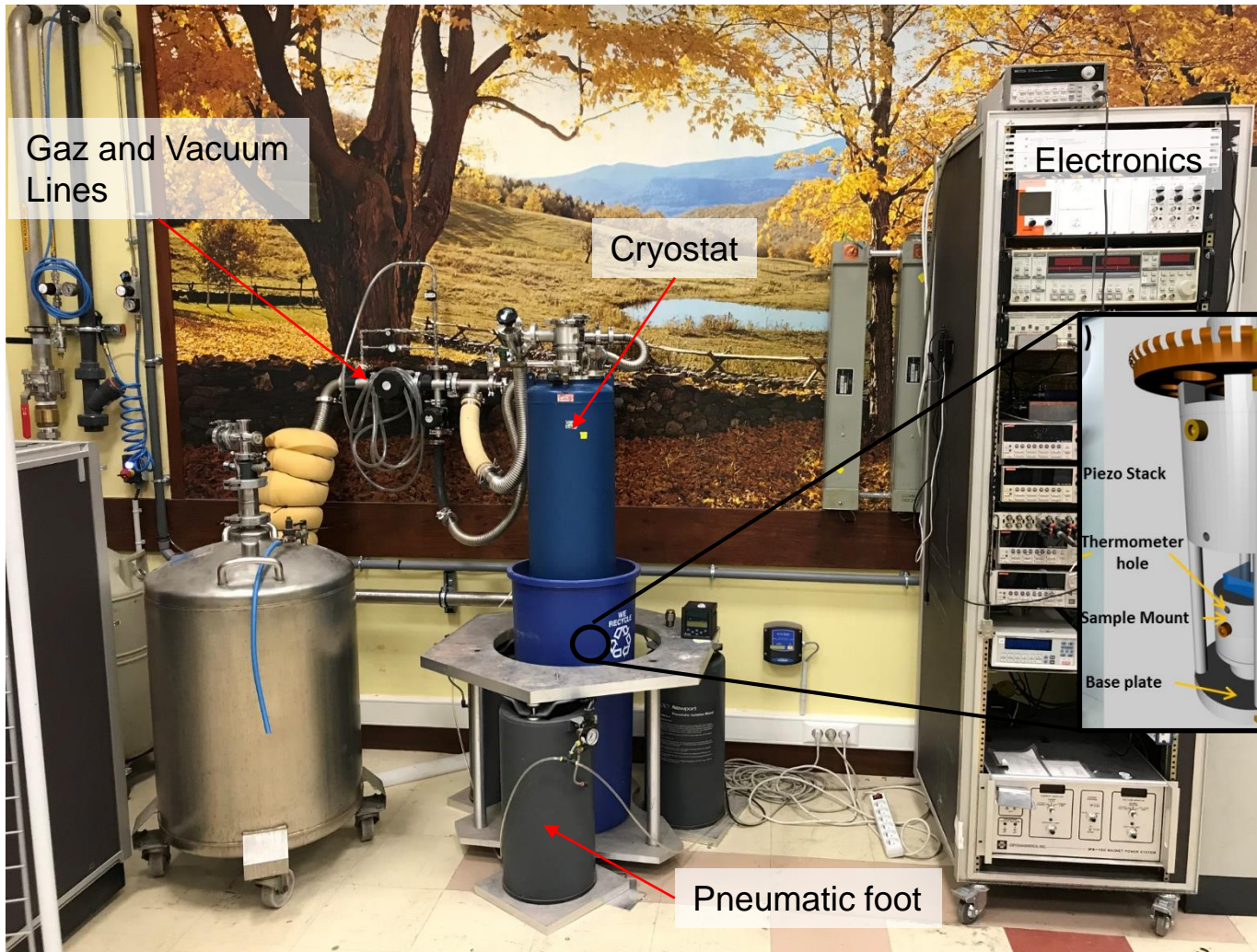

- Temp: 1,4 K
- Magnetic field: 6 T
- Cartography: 10 μm – 1 mm
- Sample size: 10x10 mm
- Fast measurements: 100-300 junctions/5hrs
- Transport (RRR, T_c vs H applied...)
- Hall Effect

Used for Nb/Cu, bulk Nb doping, Nb₃Sn, multilayers etc...

Correlations between Tunneling Spectroscopy and SRF cavity performances

- Point Contact Tunneling spectroscopy
- Bulk Nb treatments
- Nb₃Sn/Nb
- Summary and future

Tunneling spectroscopy: Bulk Nb HFQS

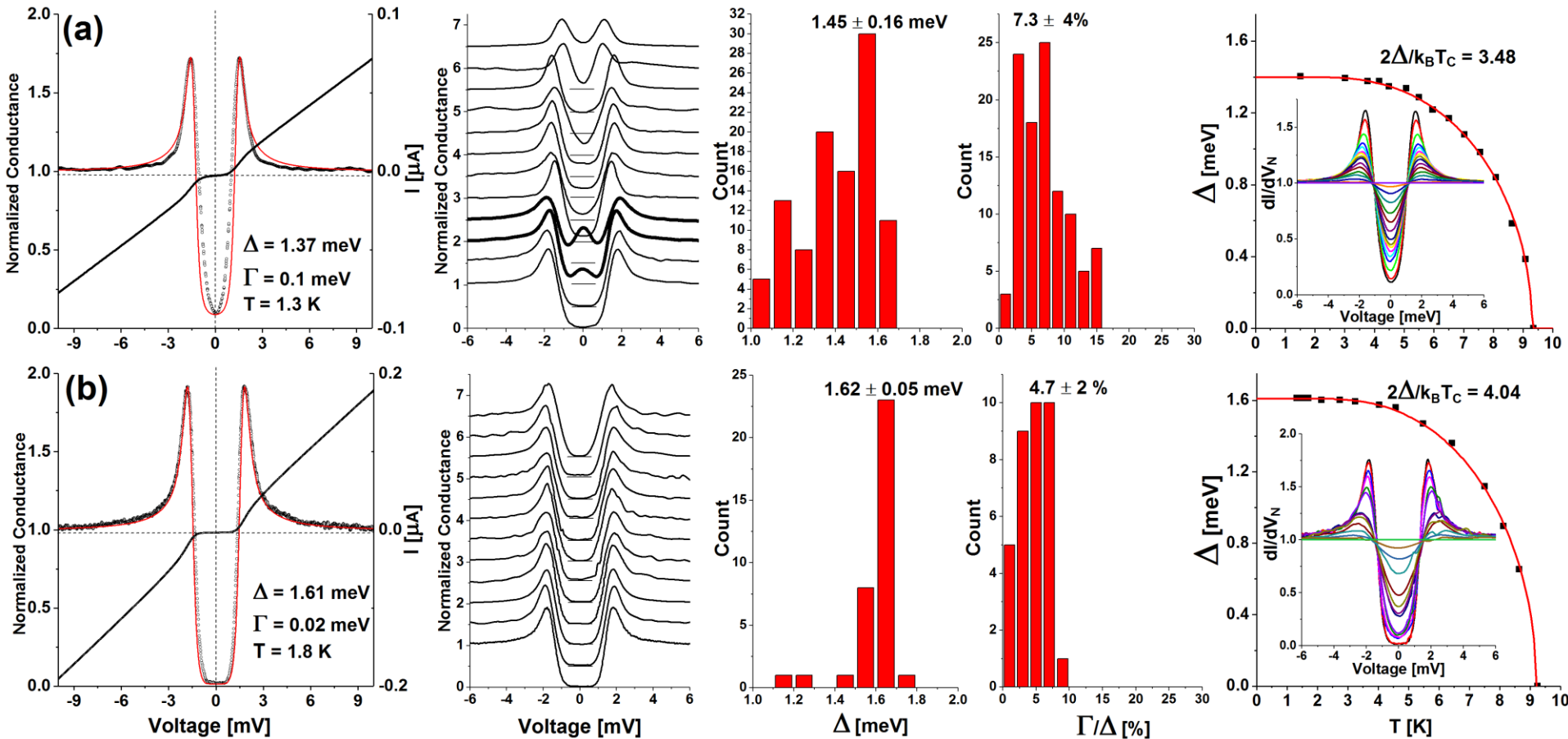

Hot Spots:

- spread of gap values as low as 1 meV
- Inelastic scattering parameters Γ
- Zero Bias Peaks

Cold Spots:

- Narrow gap distribution 1.6 meV
- Lower Inelastic scattering parameters Γ
- No zero bias peaks

Tunneling spectroscopy: bulk Nb - Why small gaps?

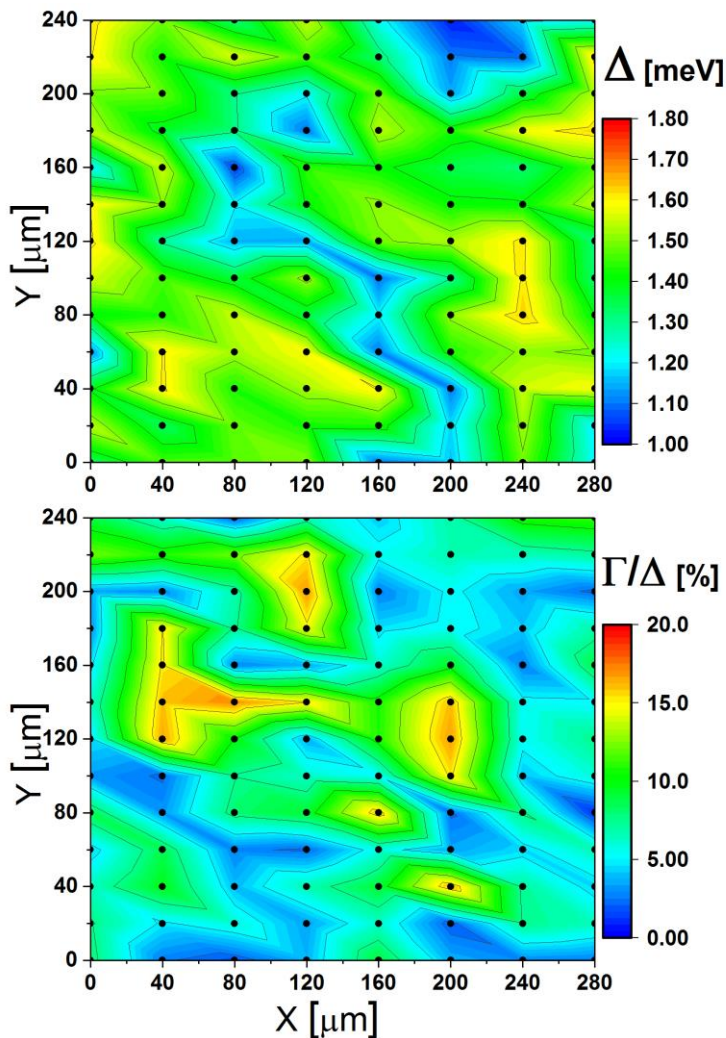

Proximity effects: MacMillan Model

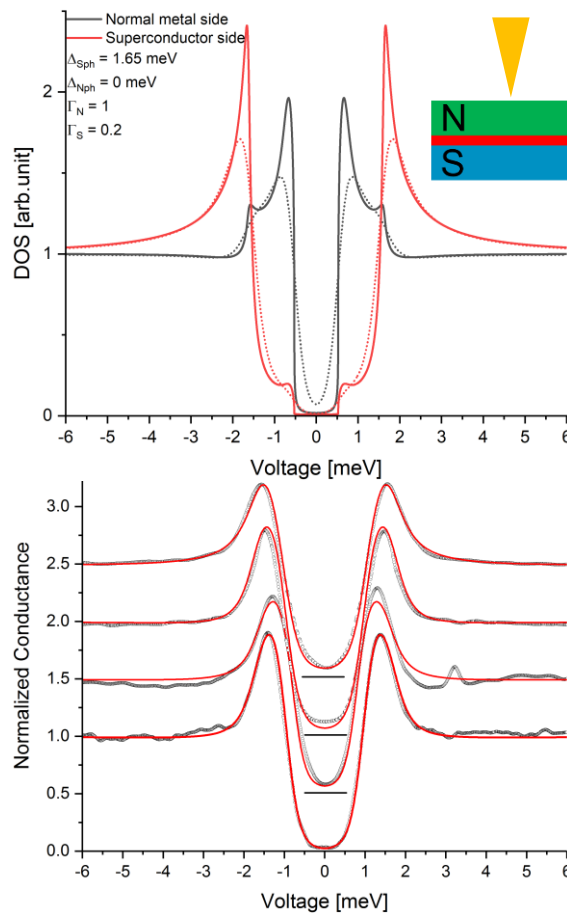

- Any Temperature.
- Diffusive scattering
- Low transparency interface ($\sigma=0.1$).
- No spatial dependence

- $\Gamma_S, \Gamma_N, \Delta_{Sph}, \Delta_{Nph}$
- $\Gamma_{N/S} = \hbar \cdot V_{FN/S} \cdot \sigma / (2 \cdot B \cdot d_{N/S})$
- Distinguish btw buried and surface normal metal phases

$$\Gamma_S \ll \Gamma_N \rightarrow d_N \ll d_S$$

$$\Delta_{Sph} (1.6 \text{ meV}), \Delta_{Nph} (0 \text{ meV})$$

- **Presence of normal metal regions:** $10 \text{ nm} < d_N < 15 \text{ nm} \rightarrow$ reduce the quench field of SRF cavities: $H_B \sim \Phi_0 / (6 \lambda_N d_N)$ Onset at 100 mT $\rightarrow d_N \leq 20 \text{ nm}$ consistent with PTC. Transparent at low fields (Q0) but revealed at « higher » accelerating gradients.
- Candidates: Nb Hydride phases at the surface (XRD at 90 K no sign of NbH_x phases)

Tunneling spectroscopy: Nb Doping: N and Ti

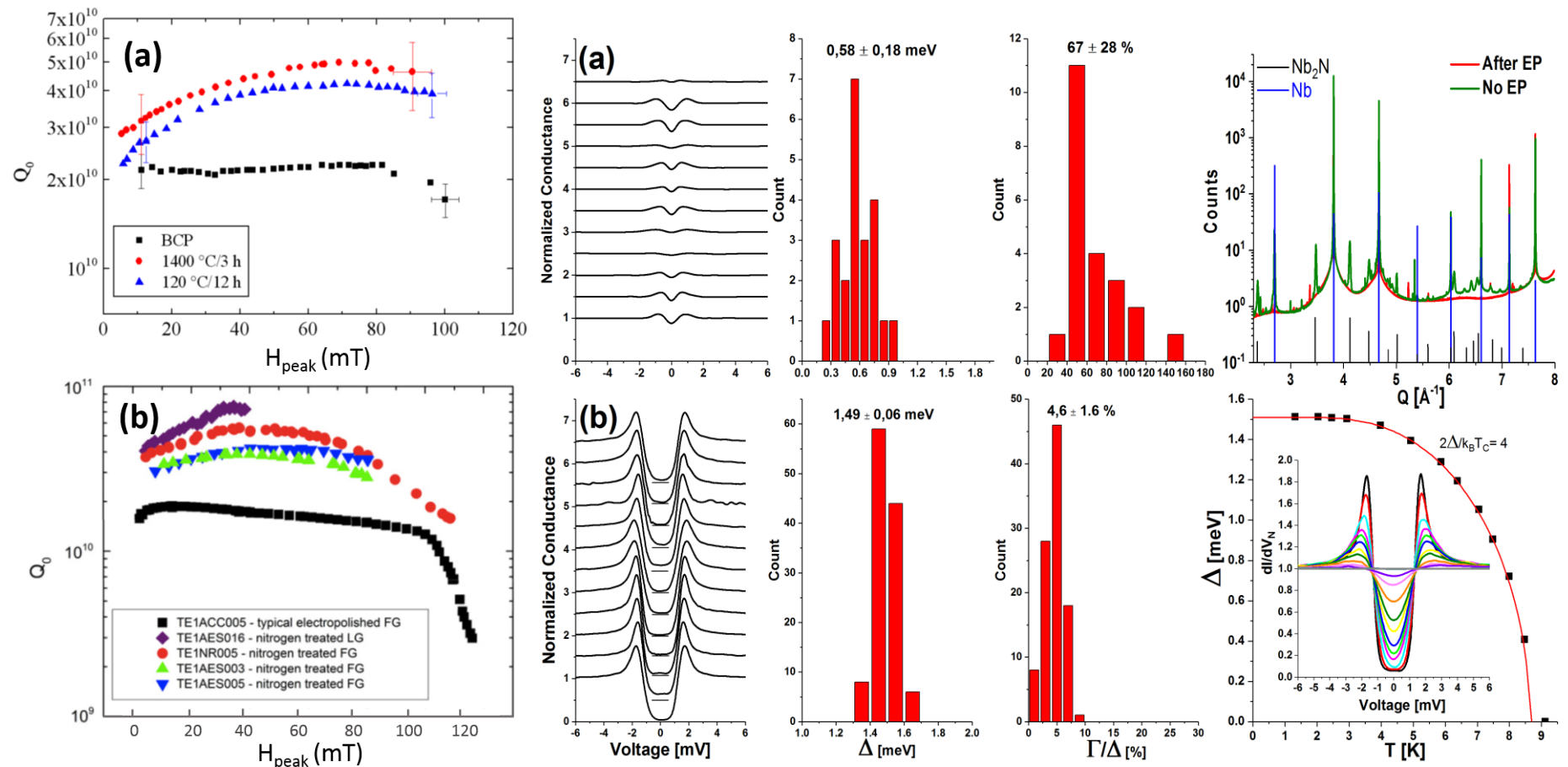

■ N / Ti Doping:

- Narrow gap distribution
- Very low Inelastic scattering Γ values
- Near ideal DOS
- No Zero Bias Peaks

■ But:

- Gap values a bit lower (1.48 meV) than bulk Nb (1.6 meV)
- T_c (8.7 K) < Bulk Nb T_c (9.2)
- Ratio $2\Delta/k_B T_c = 4$ (similar to this cavity)

High Bias region

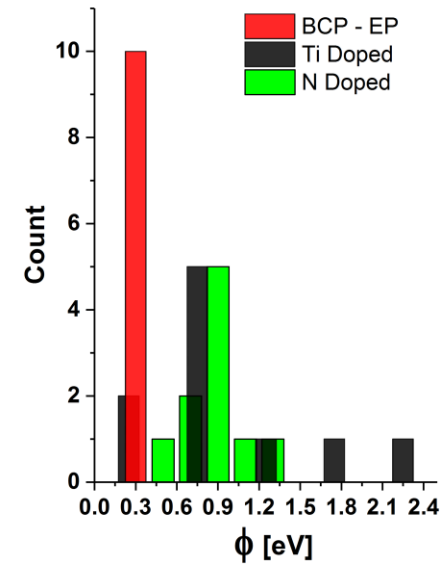
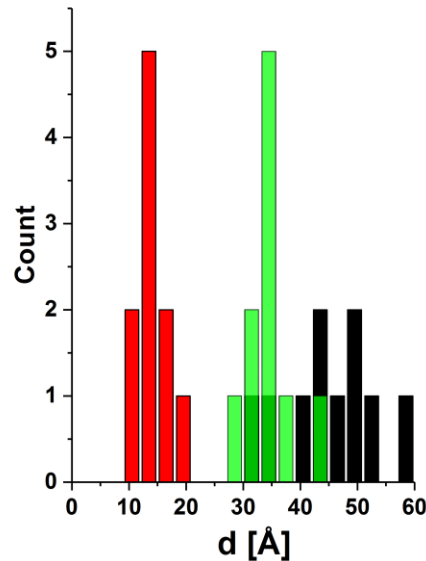
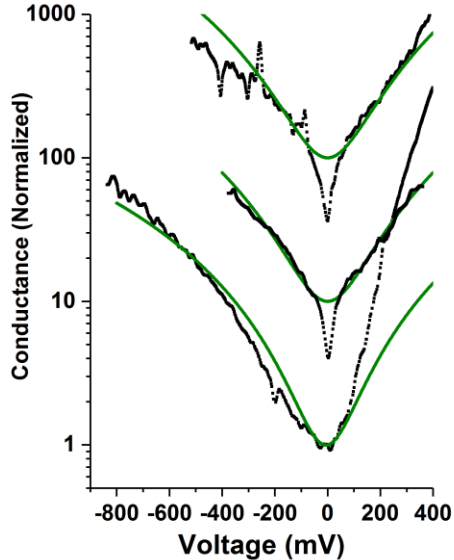

$$\frac{G(V)}{G(0)} = 1 - \left(\frac{A_0 \Delta \phi}{16 \bar{\phi}^{3/2}} \right) eV + \left(\frac{9}{128} \frac{A_0^2}{\bar{\phi}} \right) (eV)^2$$

d, thickness of the oxide
 Φ , work function of the oxide
 Φ_{TIP} , work function of the tip

- Undoped: reduced barrier height and thickness
 - Doped (Ti or N): higher barrier height and thickness
- Points towards defects in the oxide mitigated by addition of dopants:
- TLS – Hydrogen relationship and ZBP as signature
 - *Qbits : magnetic impurities, H + O(?) as a source of it*
 - *Low fields measurements*

Correlations between Tunneling Spectroscopy and SRF cavity performances

- Point Contact Tunneling spectroscopy
- Bulk Nb treatments
- Nb₃Sn/Nb
- Summary and future

Nb₃Sn/Nb (Cornell)

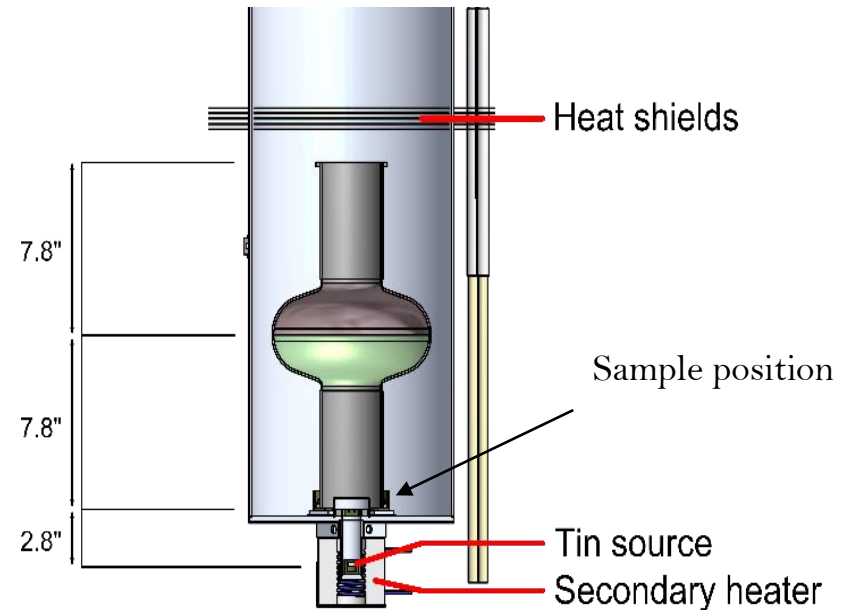
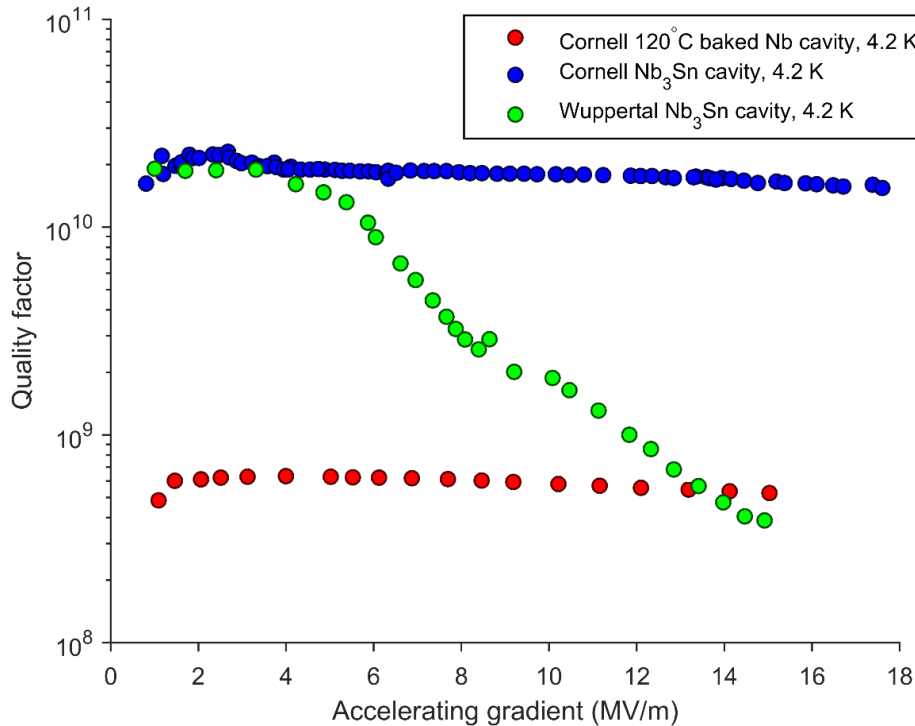

- Wuppertal method: diffusion of Sn in a Nb cavity
- Nb₃Sn Q₀ at 4,2K ~ Nb Q₀ at 2K
- Moderate increase of Q₀ between 4K to 2K -> Non-BCS
- Q₀ decrease at ~ 6K

Have we reached the limits of Nb₃Sn ?

Nb₃Sn cavity RF tests

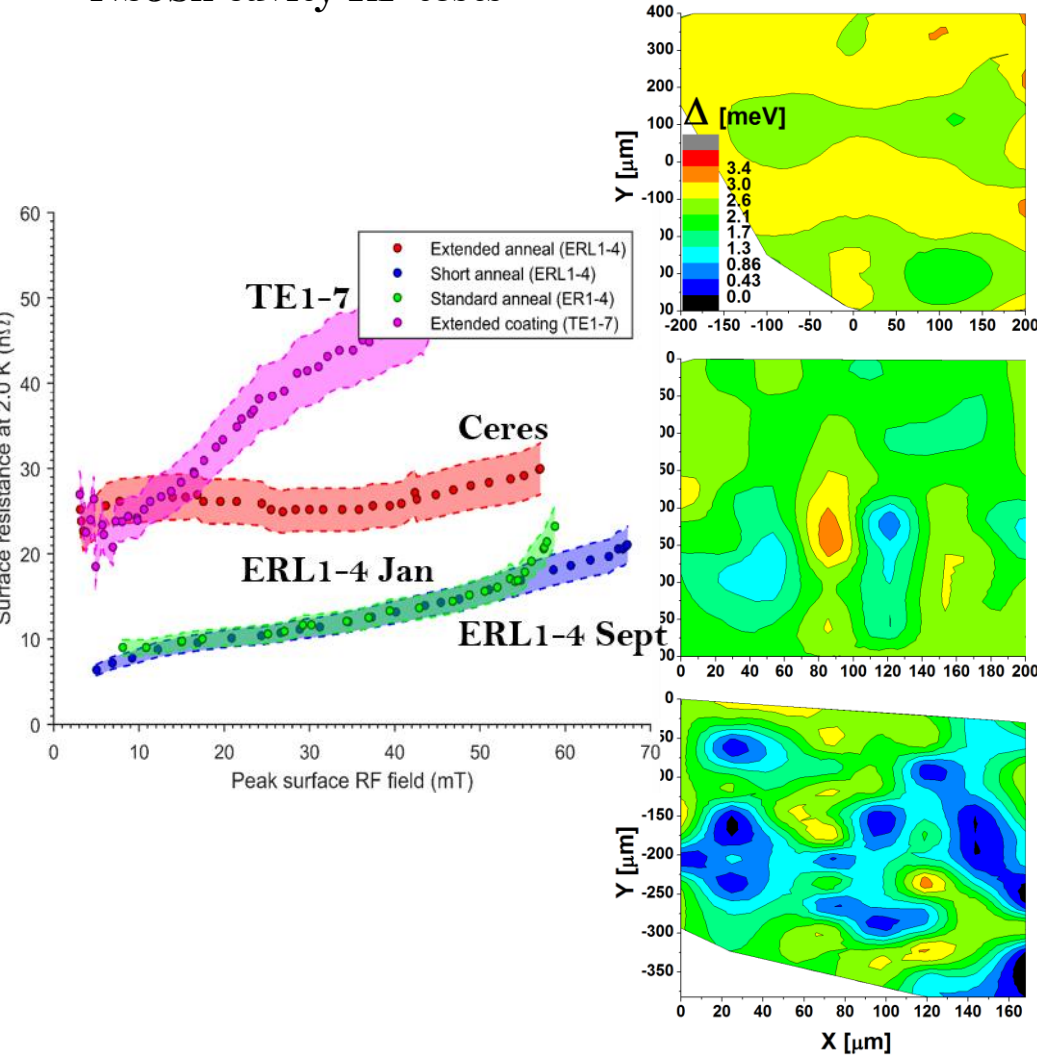

PCTS measurements

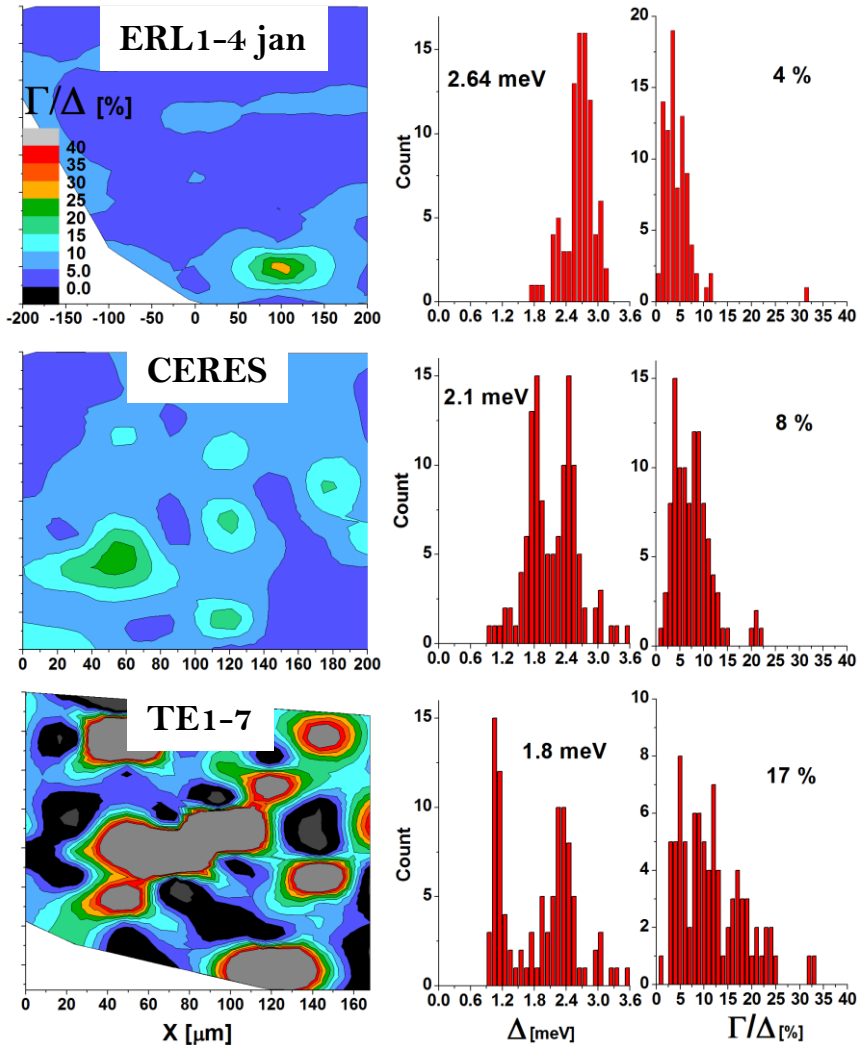

- $\Delta > \text{Nb}$ and Γ/Δ is small
 -> Quality factor @ 4K is $\sim \text{Nb}$ @ 2K

- But pockets of Nb rich phases:
 - Lower Tc and Δ
 - Carbon contamination

Nb₃Sn/Nb (Cornell) – TEM

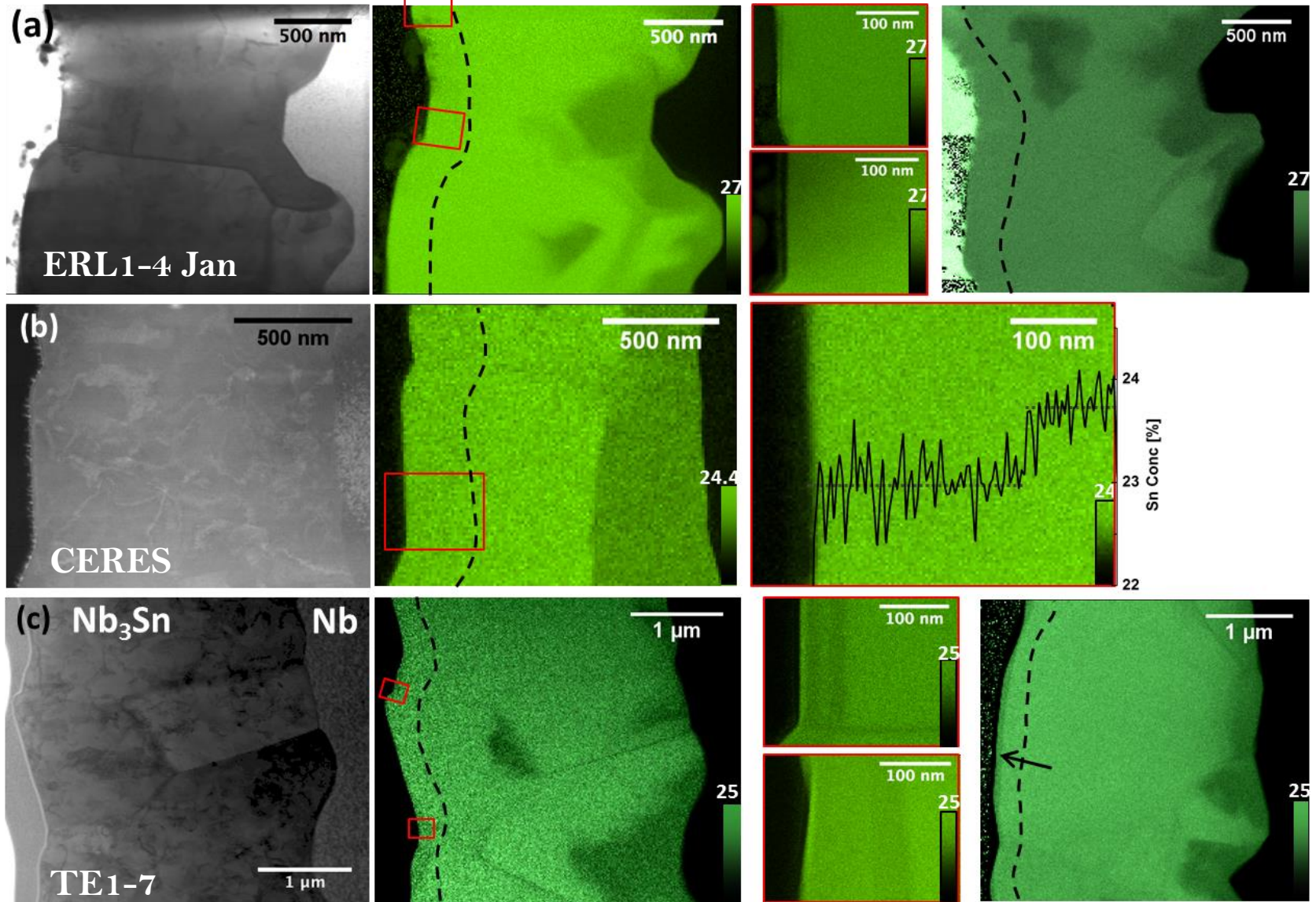

- phase rich Nb ~ 17.5 - 23%
- Interface Nb-Nb₃Sn , grain boundaries
- **Pockets near the surface**
- Crystallites ~ 100 - 200 nm (XRD)

Quench field vs Average Gap

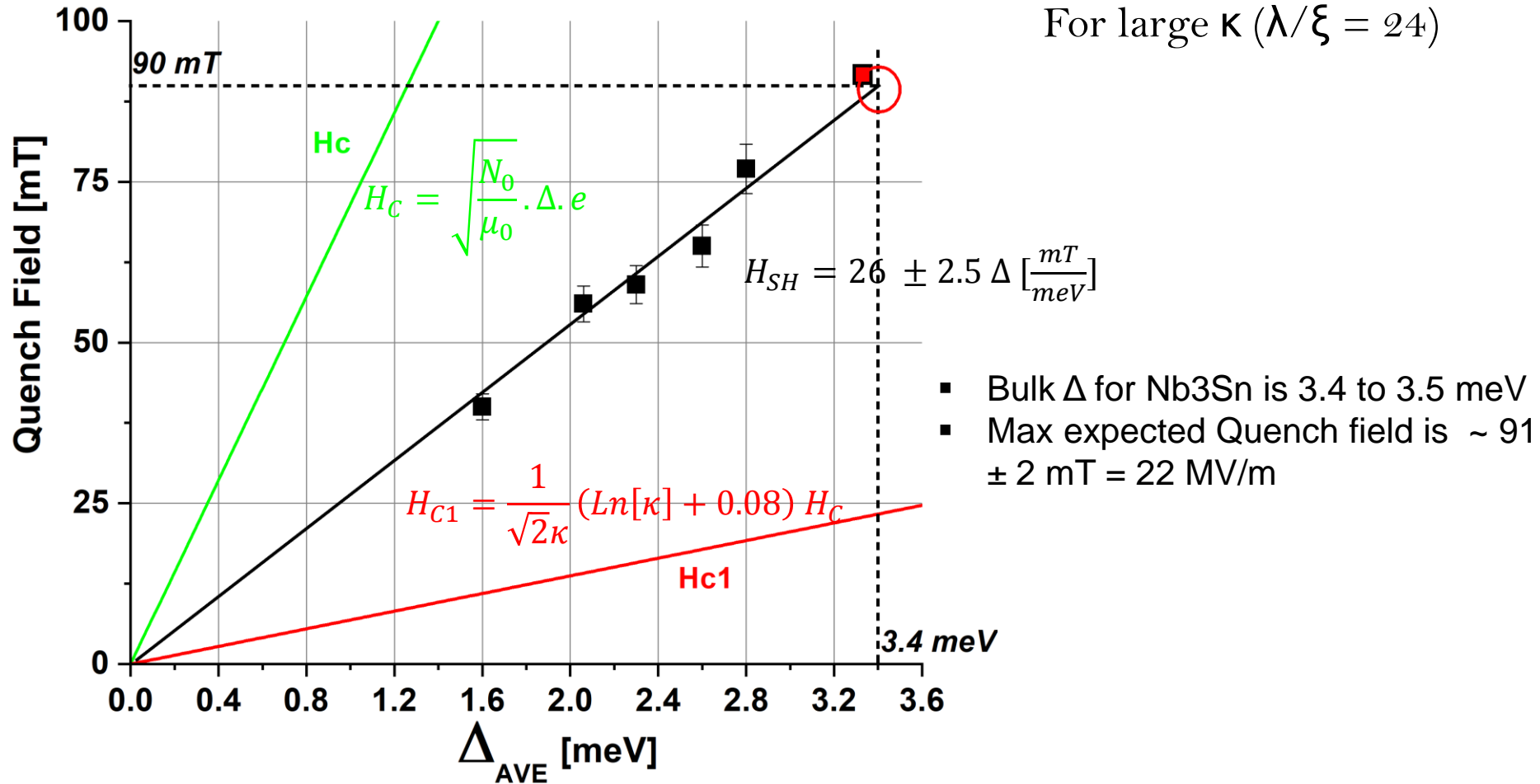

- Linear dependence of E_{max} on the average surface gap ($\sim 300 \times 300 \mu m$)
- $H_{SH} \sim 3.5$ times the H_{C1} but why this gap dependence? Roughness, effective penetration depth?
- A15 compounds (V_3Si , Nb_3Sn , Nb_3Al ...) are good for Q_0 and higher operation temp. (4,2 K)
- But what about E_{MAX} ? How to increase E_{MAX} ?

Correlations between Tunneling Spectroscopy and SRF cavity performances

- Point Contact Tunneling spectroscopy
- Bulk Nb treatments
- Nb₃Sn/Nb
- Summary and future

Summary:

- Enable testing surface treatments/heterostructures on coupons prior to cavity tests
- Faster turn over and phase space exploration of growth parameters etc...
- Measurement of Nb₃Sn sample from FNAL
- Nb₃Sn : linear dependence of E_{max} and the superconducting gap.
- Nb: à déterminer.

Future:

- Faraday Cage to improve noise (ordered) ~ 3 months.
- Measure of infusion in bulk Nb and Nb₃Sn thin films from DESY, Jlab, STFC.
- Bulk Nb: Correlation between inhomogeneous properties and samples measurements
- Smaller scan areas < 1 μm.

Thanks you

The END

Funding Sources



Cartography

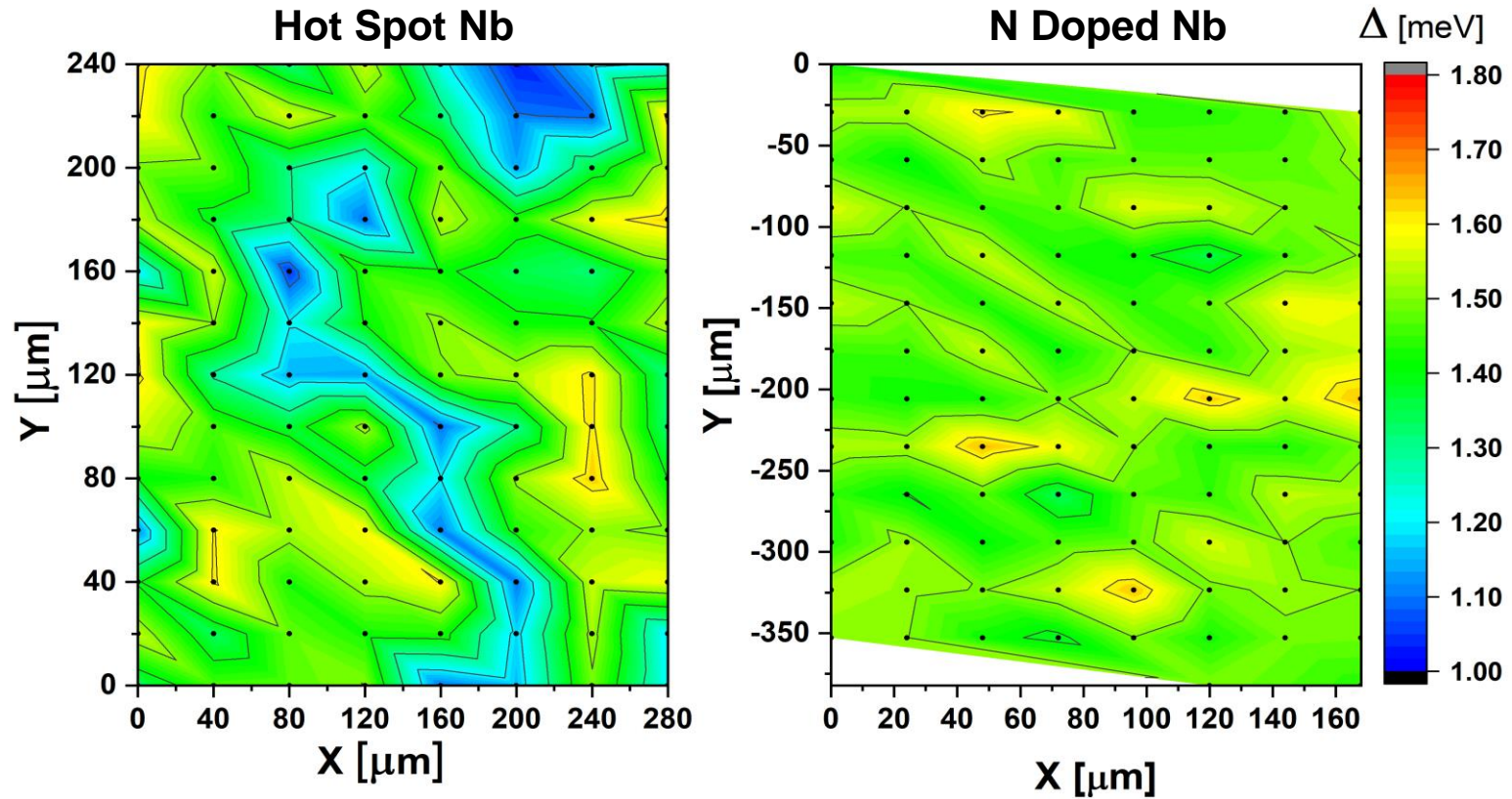

- N doping: Homogeneous bulk Nb gap values on the surface
- Hot spot: Regions with low superconducting gap values that can be fitted with normal metal regions on the surface (presumably hydrides)

Tunneling spectroscopy: what do we measure and why?

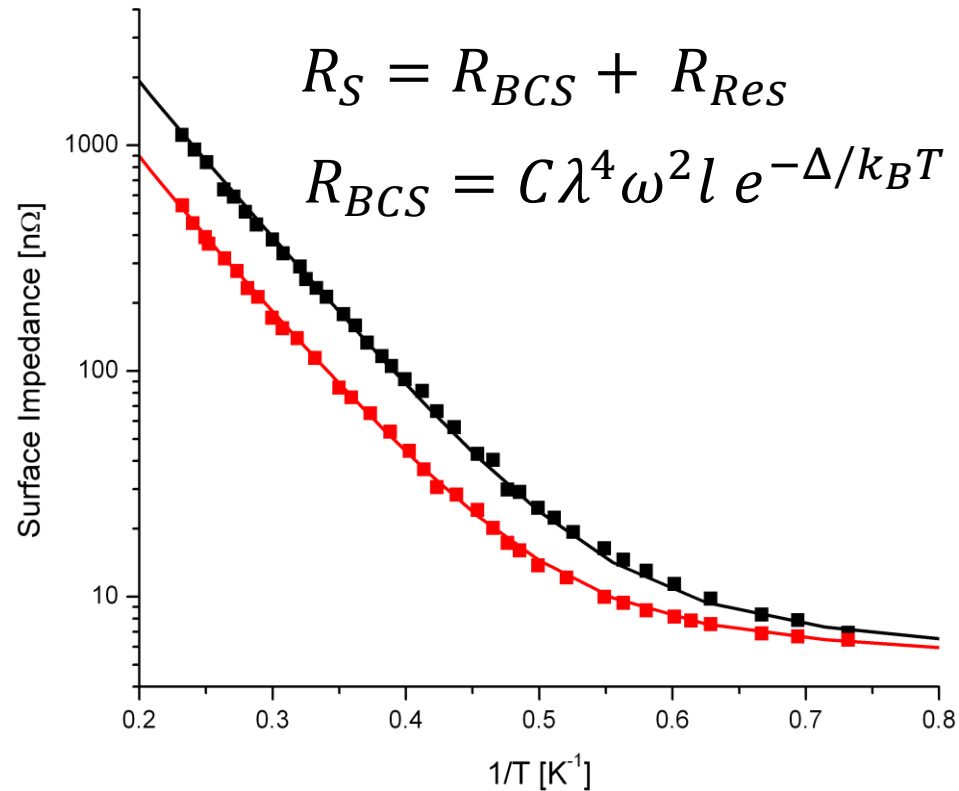
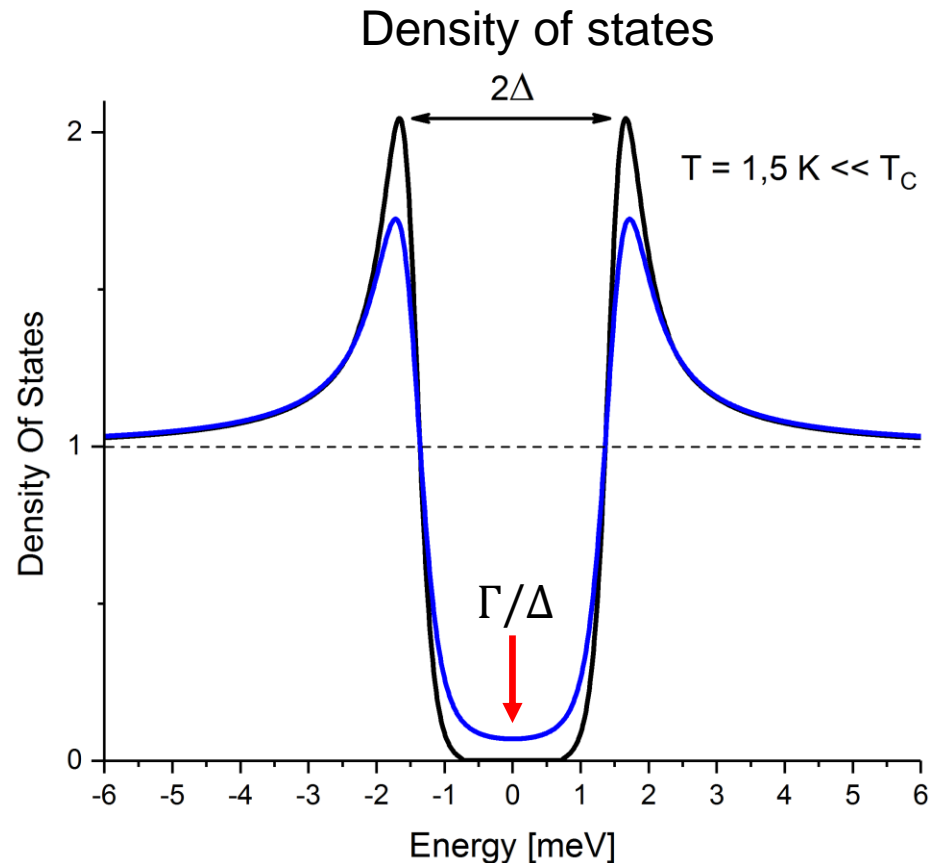

- R_S depends on $DOS(E_F)$. $DOS(E_F) (B, T, \Delta, r)$
- $DOS(E_F) \neq 0 \rightarrow$ dissipation @ $T=0 \text{ K}$
- $DOS(E_F) (B, T, \Delta, r)$, $R_S = \langle DOS(E_F) (B, T, \Delta) \rangle_r$
- Saturation mechanisms of the DOS? \rightarrow Inelastic scattering (Γ)
- Higher Gap (Δ) \rightarrow Higher Q

Cartography: calibration

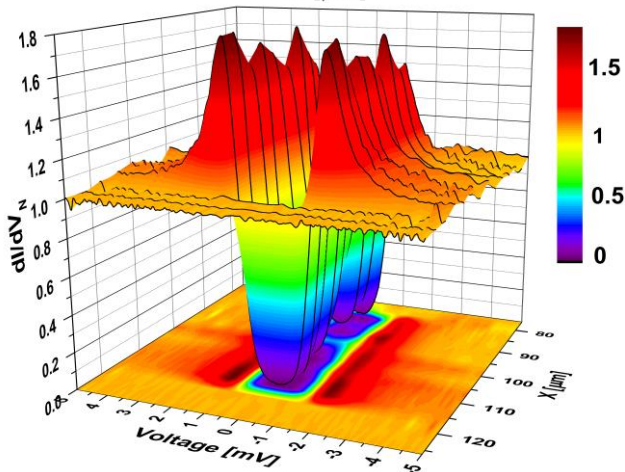
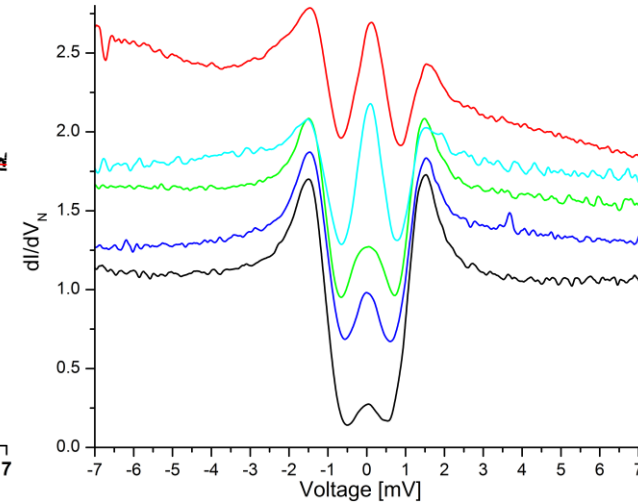
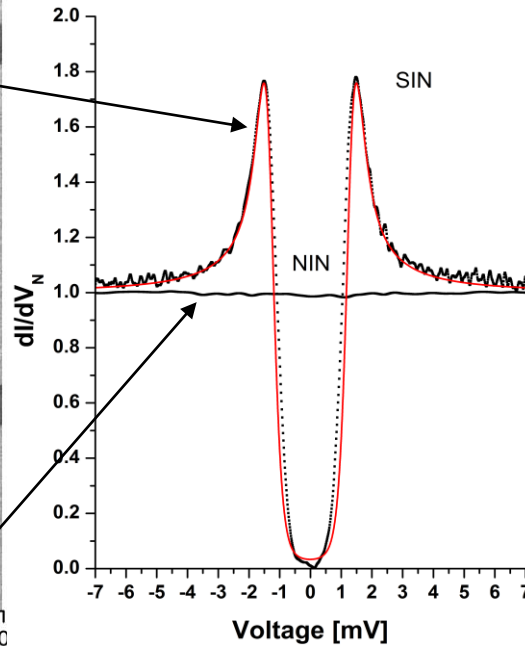
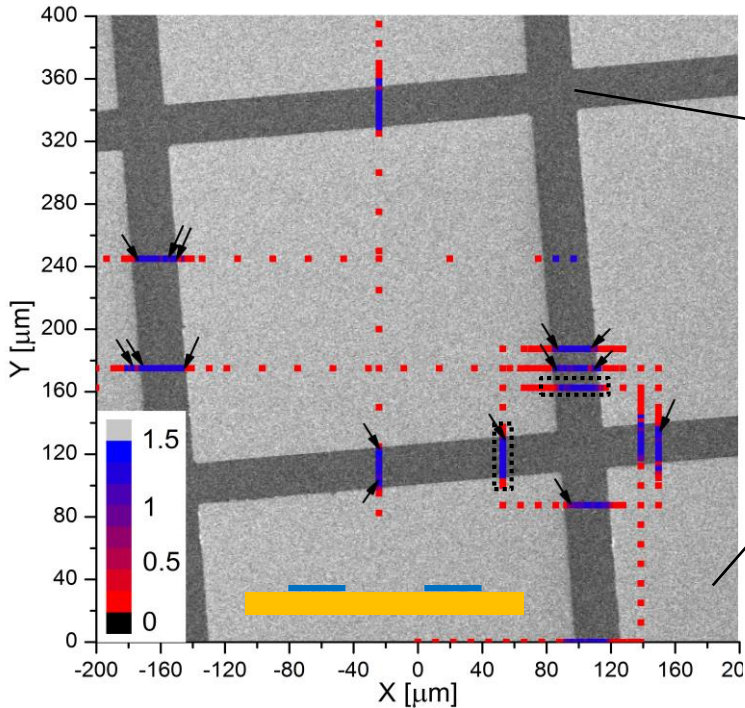
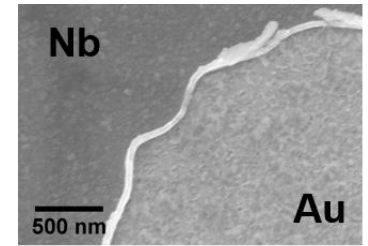

Standard:

- Lignes de Al(6 nm)/Nb (80 nm) sur Au (200 nm)
- Calibration: $X = 4,1 \text{ nm/V}$
 $Y = 4,9 \text{ nm/V}$
- Détails la DOS

Nb₃Sn/Nb (Cornell) - Magnetometry

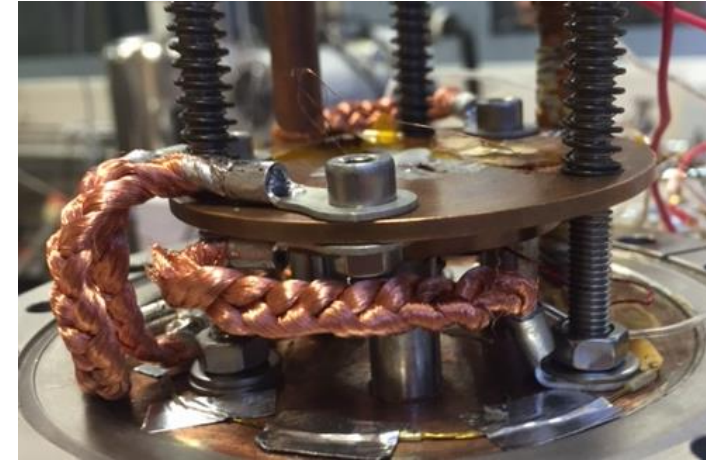
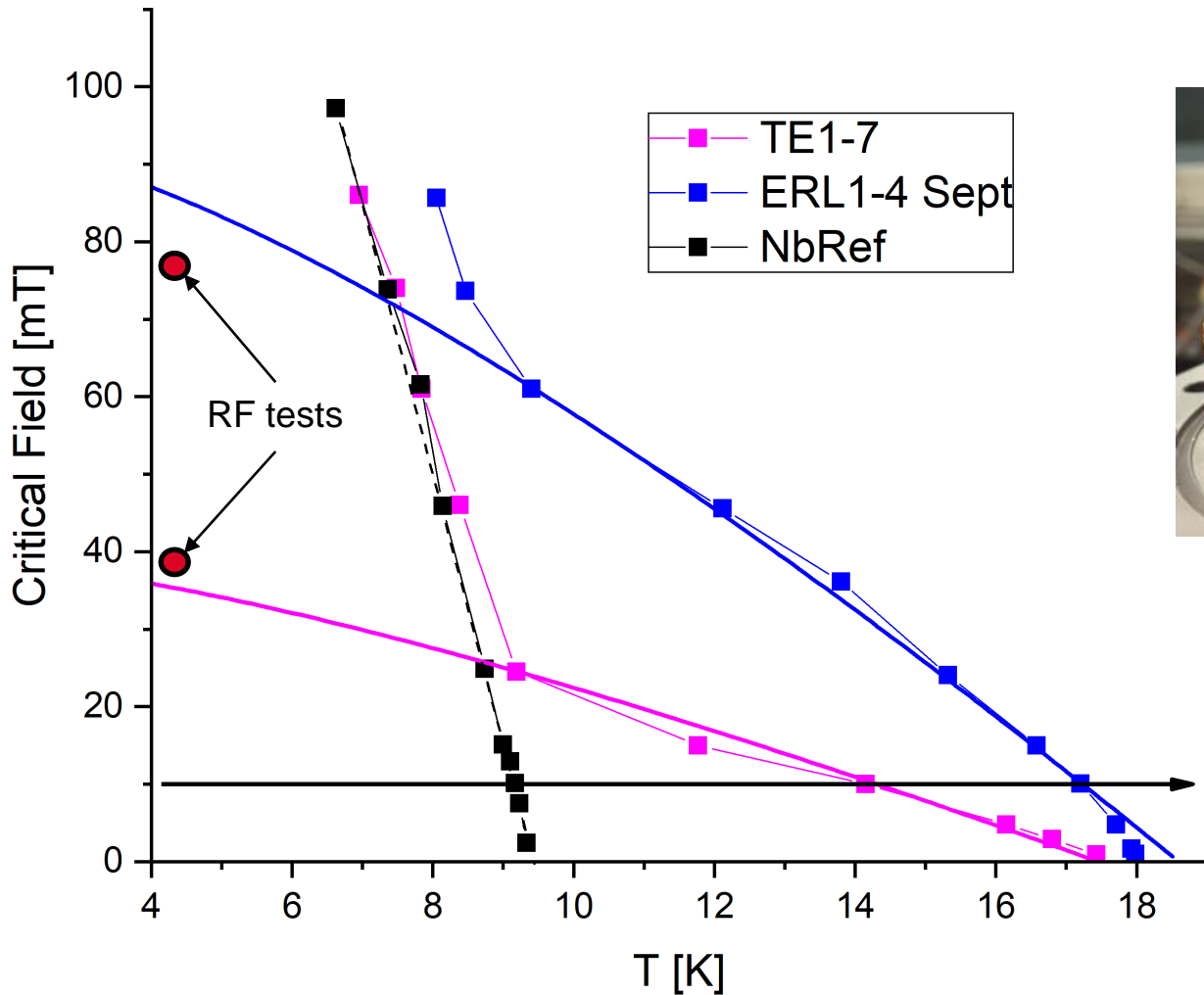

- Measure critical penetration field In Bulk and thin films samples
- Sample size: > 1 inch
- 4.2 K and 120 mT

- The critical field measured by Magnetometry correlates with RF tests Quench fields

Comparison Theory - experiments

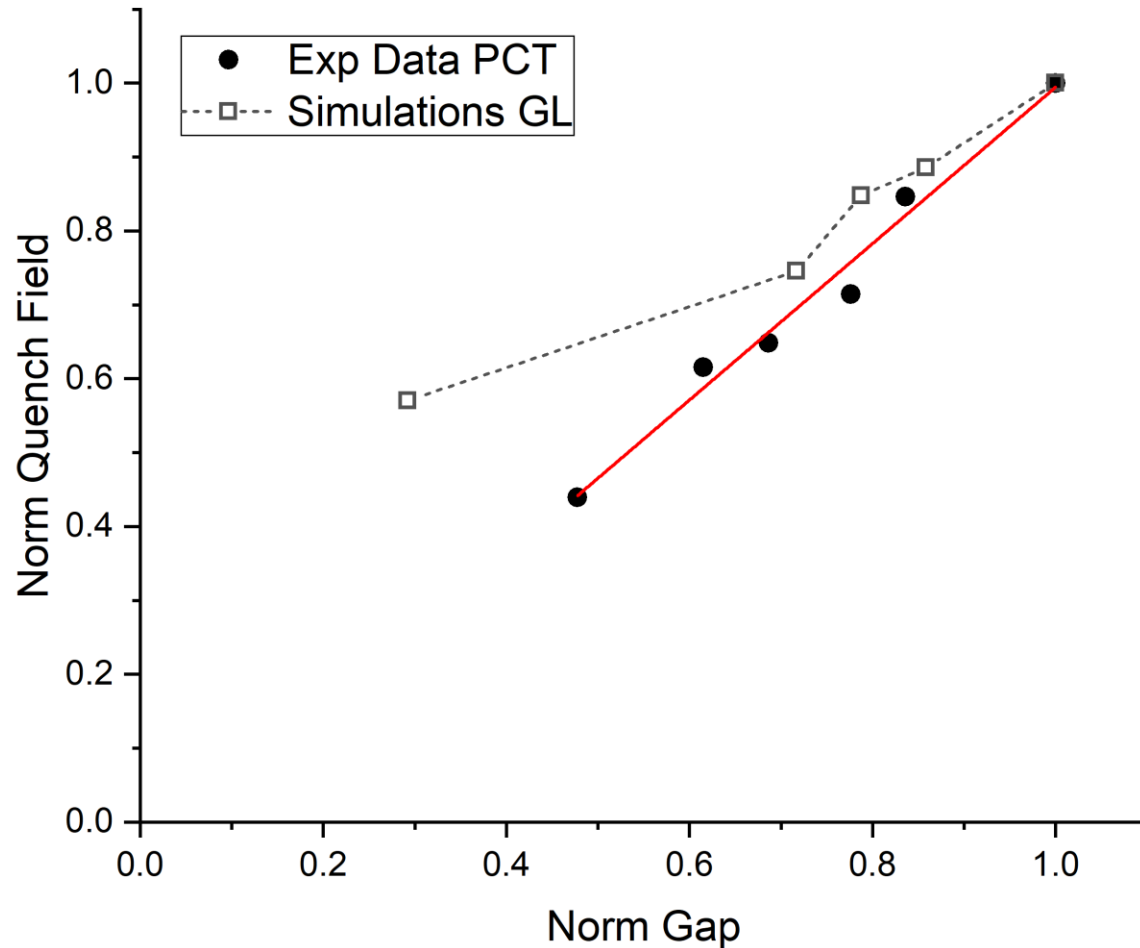

- Qualitative agreement between GL simul and PCT data
- To be continued

Nb₃Sn/Nb - simulation

Case of surface layer Low Tc 6K + lower bulk Tc 14K

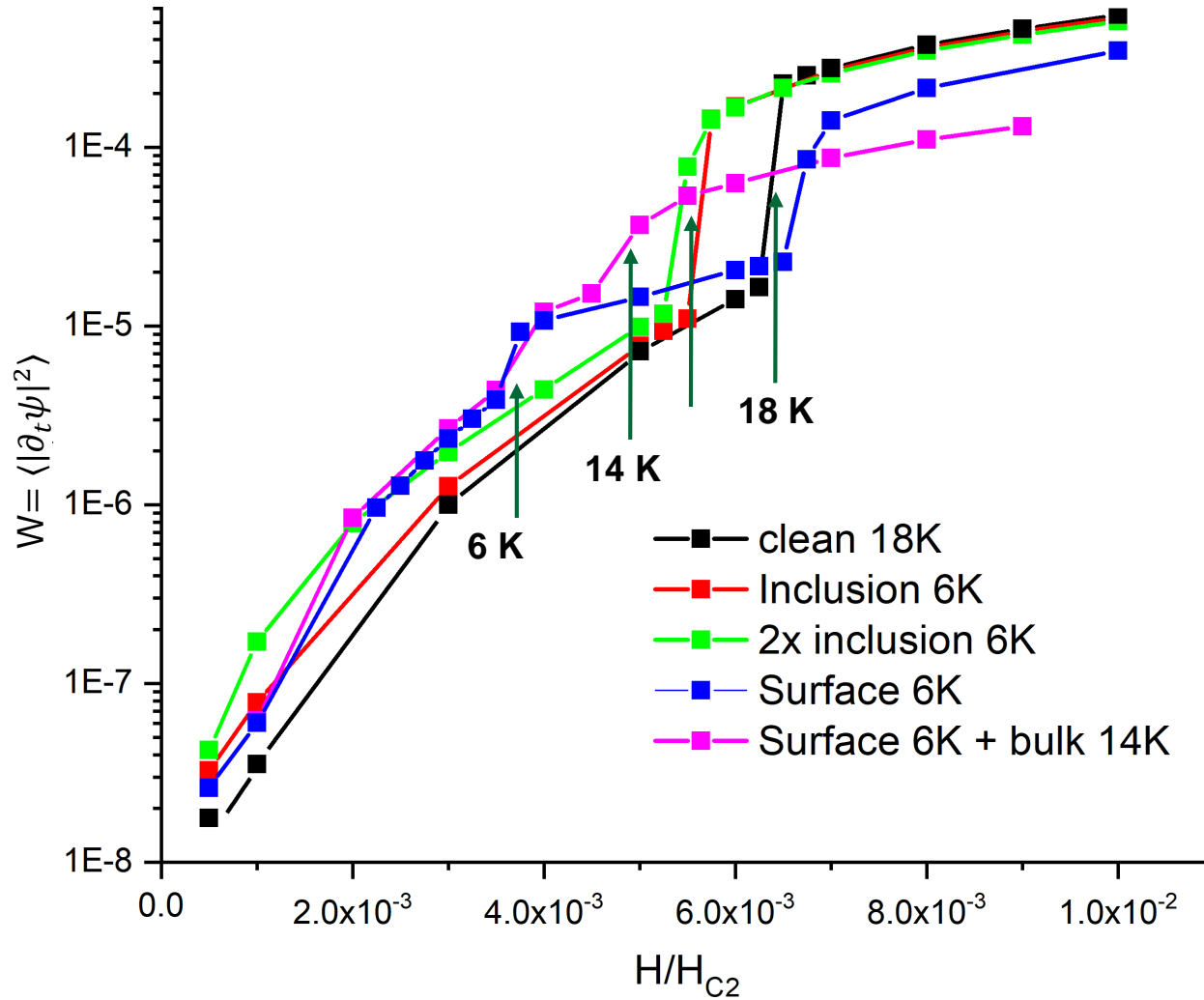

- Lower bulk Tc also lead to lower penetration field.