

Mechanical Engineering of Accelerator Components and Peripherals

Antti Kolehmainen, Tommi Mikkola and Tuukka Lehtinen
on behalf of CERN EN-MME



ENGINEERING
DEPARTMENT

CERN EN-MME Group

“The mandate of the MME group is to provide to the CERN community specific engineering solutions combining mechanical design, fabrication and material sciences.”

- EN-MME group size roughly 150 people
- Our main activities are:
 - Mechanical design
 - Engineering calculations and simulations
 - Production and sourcing
 - Material development
 - Mechanical and geometrical measurements
- We work on all the machines and experiments!

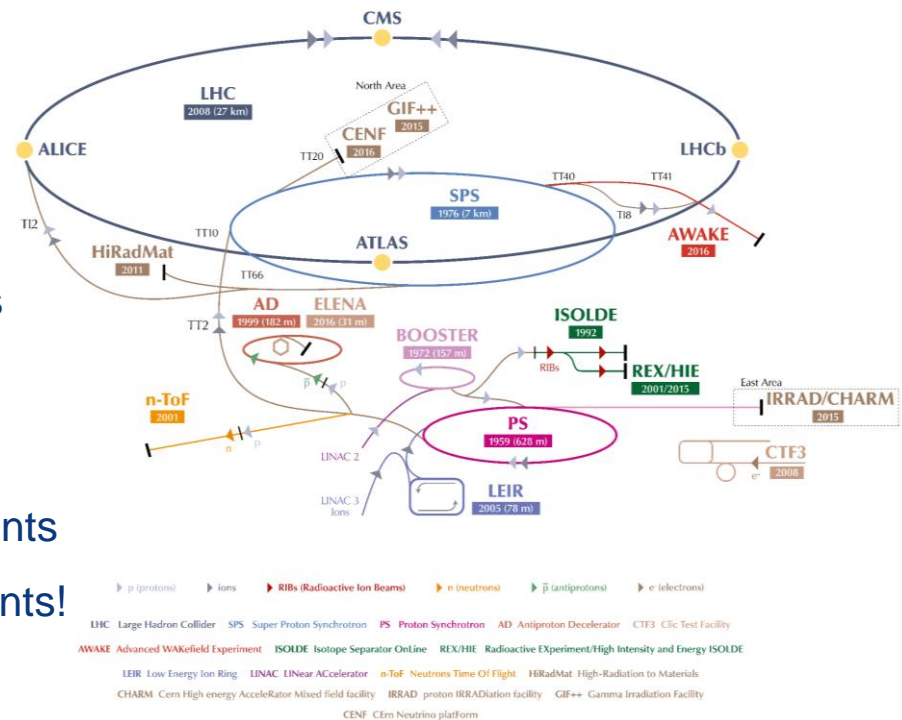

Mechanical Design – Design Inputs

Client specification

Space limitations and interfaces

Page 4 of 11

1. INTRODUCTION
This document represents the basic requirements for the 3D model of the ELENA MBR design, done in CATIA. It further represents the interface document between the magnet work package and the design office.

2. NOMENCLATURE
All the parts and assemblies established for this magnet shall follow the same nomenclature as the prototype (f.g. AD_MBHEKXXXX, where XXXX is a consecutive number).

3. SOFTWARE
For this design it has been agreed that the software used will be CATIA V5. The release version may change according to CERN procedures.

4. COORDINATE SYSTEM
The coordinate system to be observed shall be the following:

Right handed, orthogonal coordinate system to be used

- z-axis: tangential to the beam in the direction of the beam in the center of the magnet
- y-axis: vertical in the opposite direction to gravity, 0 at the magnet center
- x-axis: According to a right-handed coordinate system perpendicular to x and z (0 at mechanical pole center)

An example for the coordinate system can be found under Figure 1.

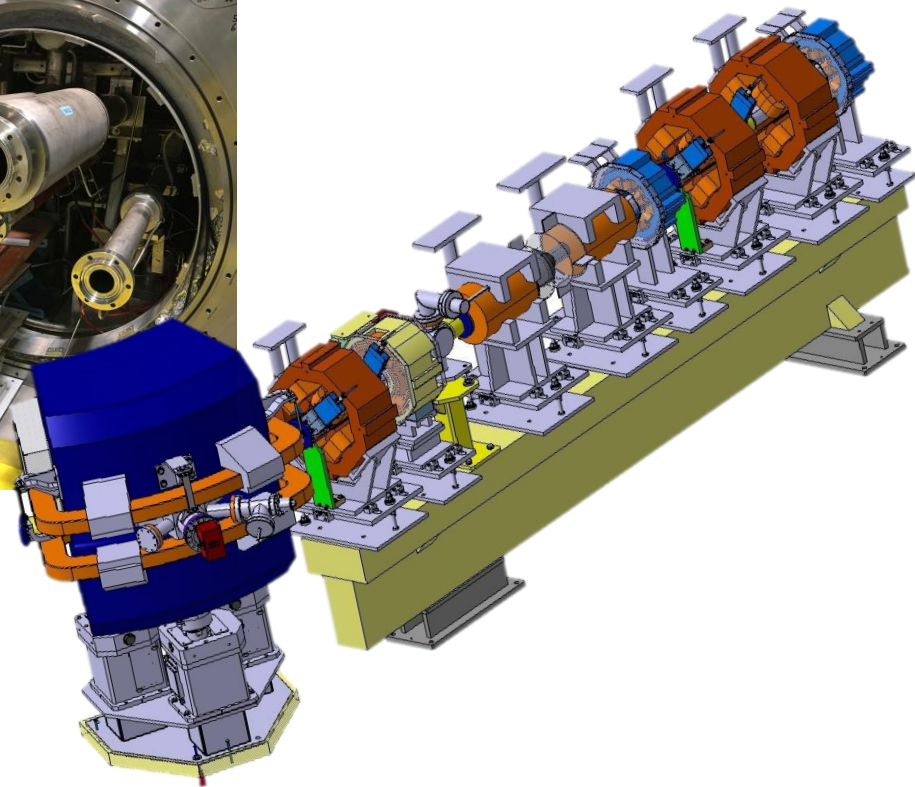
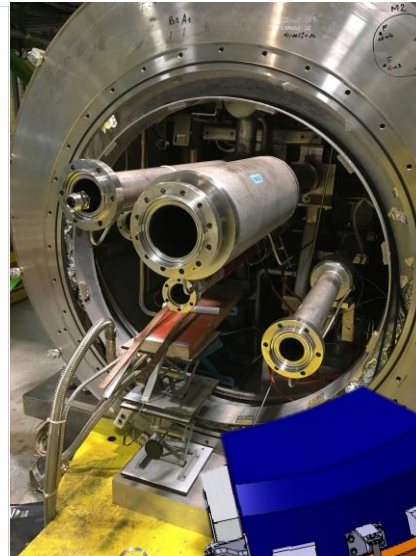
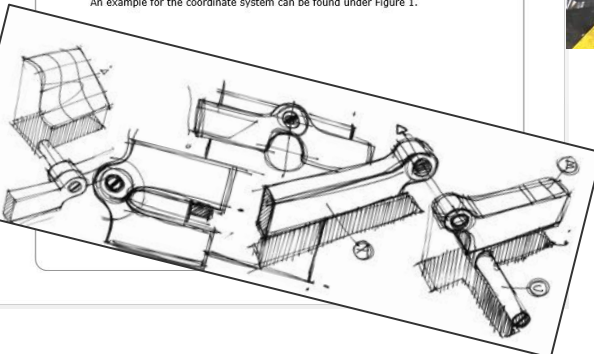

All project parties partake in defining design inputs!

Mechanical Design – Process

Iteration:

- Designer – Client
- Analysis, simulation
- Integration
- Manufacturing

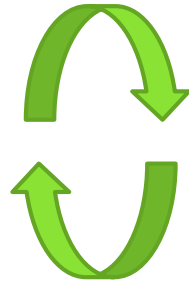

Deliverables:

- 2D drawings
- 3D models
- Supporting documents, such as analysis or measurement reports

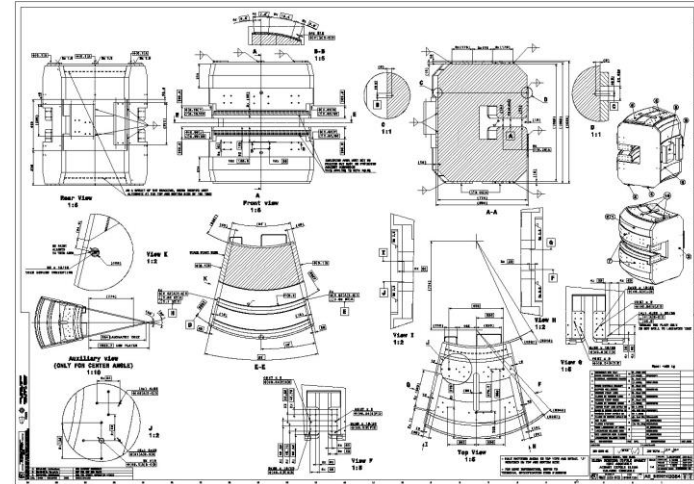
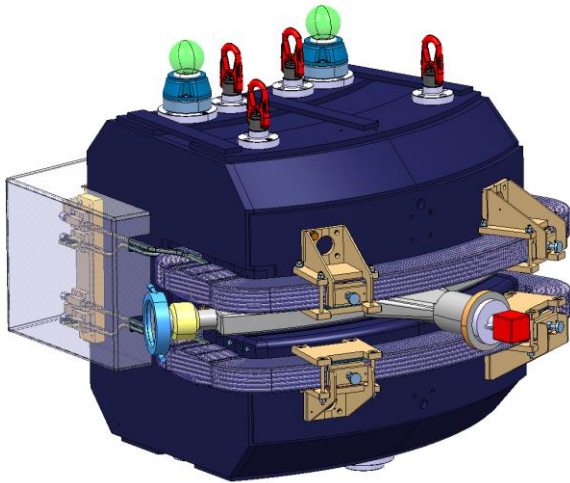

Engineering Calculations and Simulations

Why: To guide design work, to meet requirements, and to assess safety

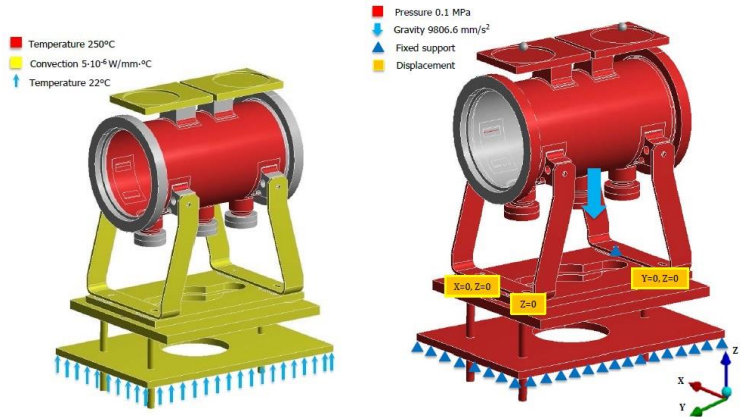

Figure 5 - Thermal boundary conditions for the quadrupole

Figure 6 - Boundary conditions and loads for the structural analysis.



Boundary conditions

Functional device

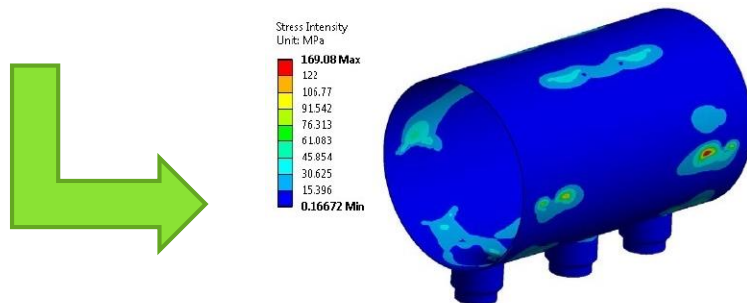

Figure 10 - Stress intensity for the vacuum vessel.

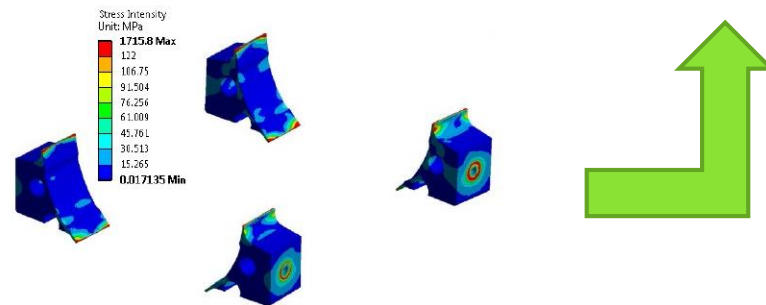

Figure 11 - Stress intensity for the welded connectors.

Analysis results

Manufacturing and Production

- EN-MME operates three machine shops mostly for prototype and small series production
- Capabilities:
 - Machining: Milling, turning, drilling, cutting, grinding, electrical discharge machining, etc.
 - Forming: Sheet metal bending, rolling, punching, pressing, extrusion, etc.
 - Joining: Welding, brazing, soldering, etc.



Material Development and Measurements

Material development examples:

- Graphites for beam impacts
- Stainless steel alloy for permeability

Mechanical measurement examples:

- Non-destructive testing: X-ray for LHC dipole magnets
- Destructive testing: Material tensile strength testing

Geometrical measurements: Verification of component compliance to specification (drawings and/or model)

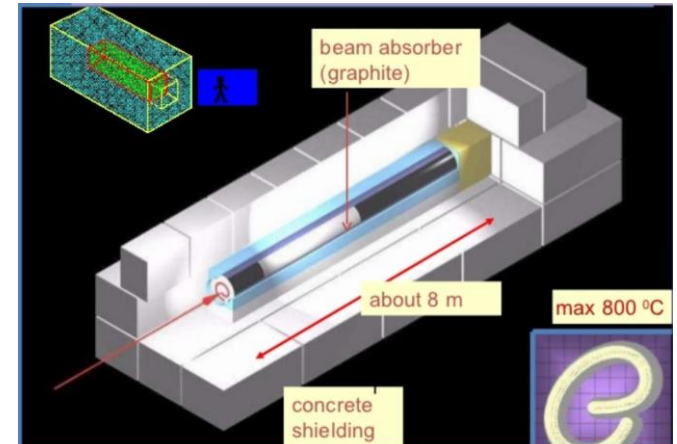



ENGINEERING
DEPARTMENT

Questions!