



Business opportunities at CERN

Slovenia @ CERN - 09 October 2019

Jérôme Pierlot



AGENDA

- **Business Opportunities @ CERN**
 - What we buy
 - Shopping List
 - HL-LHC
- **Upcoming Tenders**
- **Successful Bidders from SI**



Business Opportunities @ CERN

Suppliers Database Registration

- **Please register in CERN Database (only 38 Firms...)**
- **Please accept the GCCC:**

General Conditions of CERN Contracts

GCCC are standards, and light compared to many private companies

- **Dedicated section in the Tender form for remarks, in case of major divergence with GCCC leading to a deal-breaker situation**

... but CERN has the right to accept or not !



What we buy

- **Recurrent supplies & services**
- **Accelerator technologies required for consolidation projects and new developments**



- **Civil engineering:**

- New constructions & renovation of existing buildings
- Roads, earthworks and sewage systems
- Metallic structures



- **Cooling and ventilation equipment**

- New systems & renovation of existing buildings
- Air handling units
- Pumps



Electrical engineering

- Biggest private Network in EU
- 200 MW of installed Power
- 300 + HV Cubicles
- 350 + Transformers
- 2000 + LV Switchboards
- 300 + UPS Systems

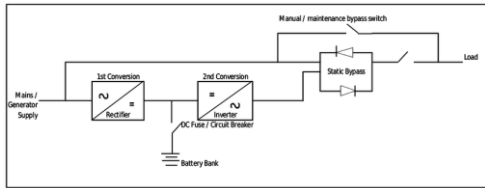

- 100 + 48 V DC systems
- 25 000 + Circuit Breakers

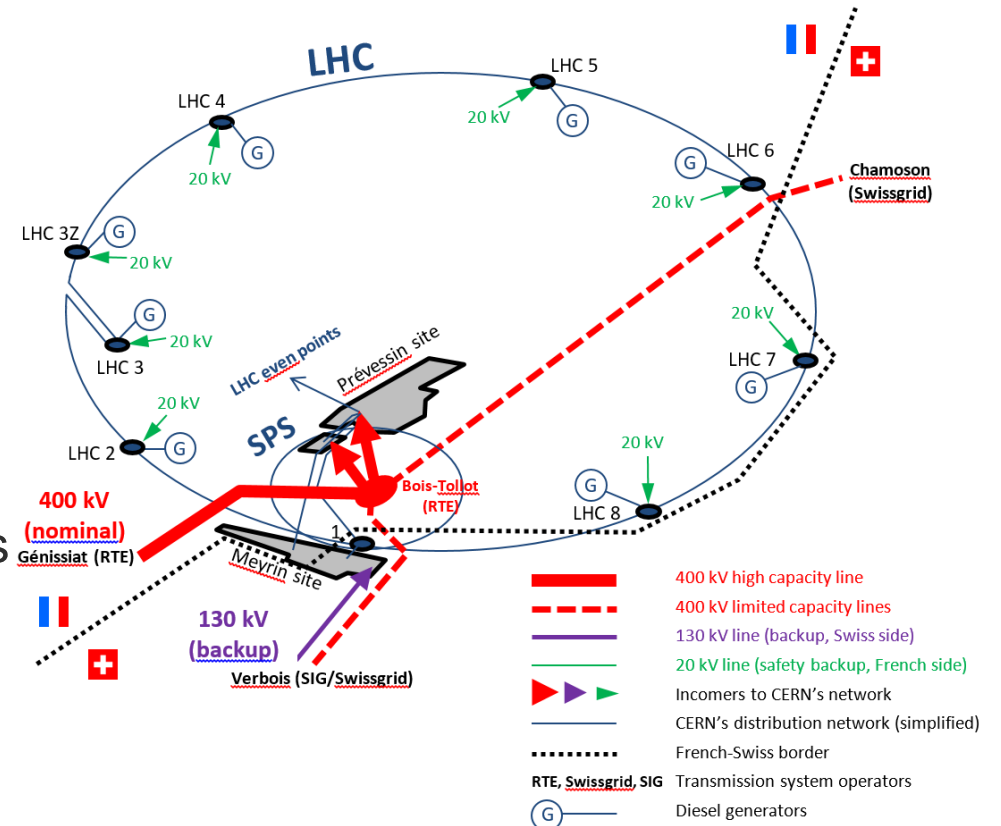



- **Information & Technology:**

- Computing systems
- Servers
- Software
- Network equipment
- Personal computer equipment



- **Magnets**

- Electro Magnets
- Permanent Magnets





- **Mechanical Engineering**

- Machining & Sheet metal work and arc welding
- Raw materials, finished and semi-finished products (plates, pipes, etc.)
- Offsite engineering and testing

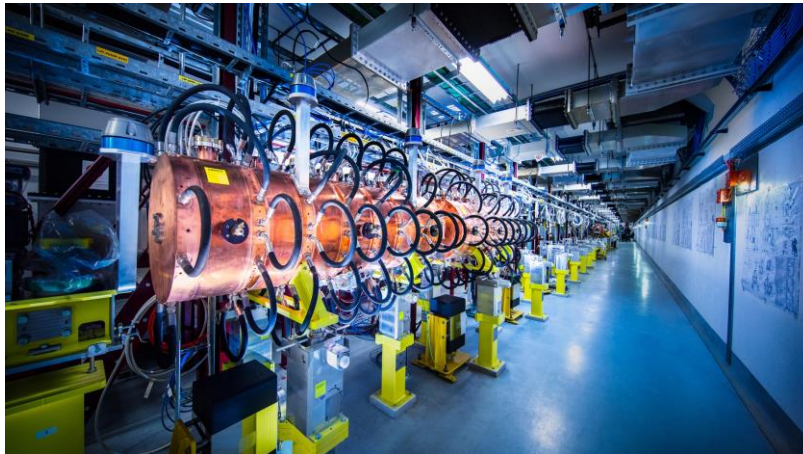

- **Electronics & RF Equipment**

- Electronic components (active, passive)
- PCBs and assembled boards
- LV and HV power supplies
- Radiofrequency equipments
- Amplifiers



- **As well as various different Supplies:**

- Cryogenic and vacuum equipment
- Particle detectors
- Health and safety equipment
- Transport and handling equipment
- Office supply, furniture, etc...

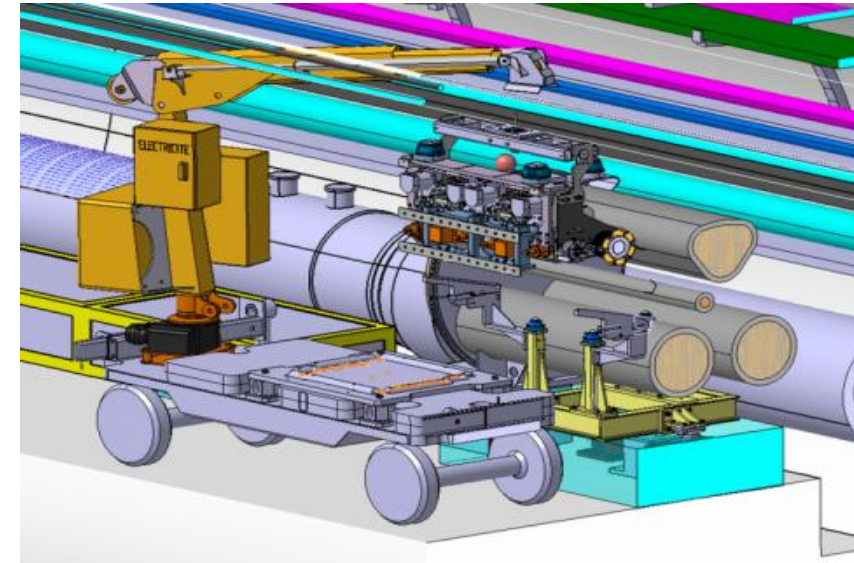
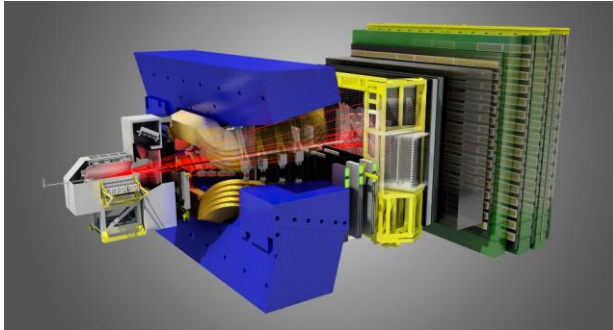



- **But also many onsite Service Contracts:**

- Access control
- Internal mail distribution
- Food & catering
- Office cleaning
- Park and gardens maintenance
- Electrical maintenance
- Cranes maintenance
- Snowplow
- ... and many more !



- **CERN buy everything that is needed to run the Organization and its accelerators !**

Supplies ↔ Services

from Office Supplies ↔ to Particles Detectors

Simple Supplies ↔ Highly Technological Supplies

3 Types of Enquiries

“Price Enquiry” (DO) :

1. Enquiries < 10'000 CHF
2. 10'000 CHF ≤ Enquiries < 200'000 CHF



“Invitation-to-Tender” (IT) :

3. Enquiries ≥ 200'000 CHF



Procurement Website

<https://home.cern/>

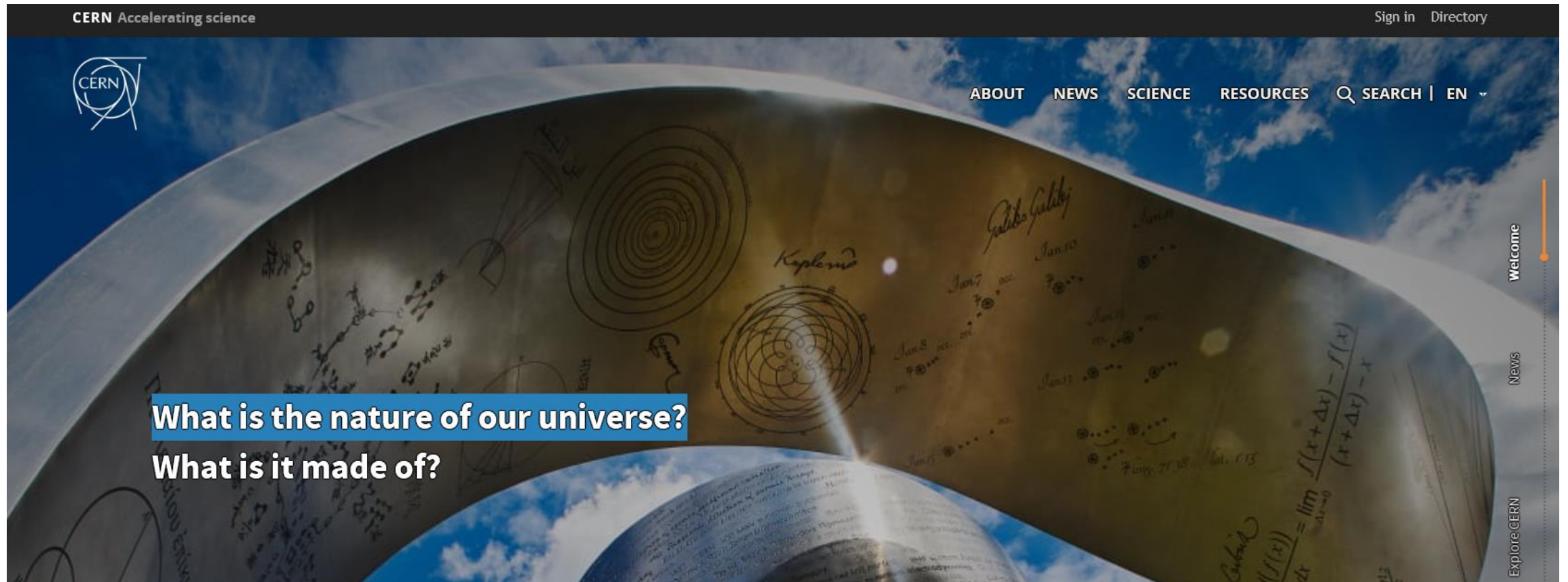

**What is the nature of our universe?
What is it made of?**

Procurement Website

› The Higgs boson

› The birth of the Web

› The High-Luminosity LHC

FOLLOW US



FIND US

- › Contact us
- › Getting here

CERN
Esplanade des Particules 1
P.O. Box
1211 Geneva 23
Switzerland

CERN & YOU

- › **Doing business with CERN**
- › Knowledge transfer
- › CERN's neighbours
- › CERN & Society Foundation
- › Partnerships
- › Alumni

GENERAL INFORMATION

- › Careers
- › Visits
- › Privacy policy

Procurement Website

The screenshot shows the top section of a website. At the top left, there is a logo consisting of a dome and buildings, with the text "Doing business with CERN" below it. To the right of the logo, the text "Procurement and Industrial Services Group" is displayed in a large, bold font. Below this, a dark blue navigation bar contains the following links: "Doing Business with CERN", "CERN Personnel", "Industrial Liaison Officers", and "Group Members". The main content area is divided into three columns. The first column has the heading "Doing business with CERN" and an illustration of a dome structure, with the text "Supplier Portal" below. The second column has the heading "Business opportunities" and an illustration of a man and a woman shaking hands, with the text "Key reference documents" below. The third column has the heading "High Luminosity LHC project" and an illustration of a particle accelerator tube with the text "Accelerating Science" on it, with the text "Who to contact" below.

Doing business with CERN

Procurement and Industrial Services Group

Doing Business with CERN CERN Personnel Industrial Liaison Officers Group Members

Doing business with CERN

Business opportunities

High Luminosity LHC project

Supplier Portal

Key reference documents

Who to contact



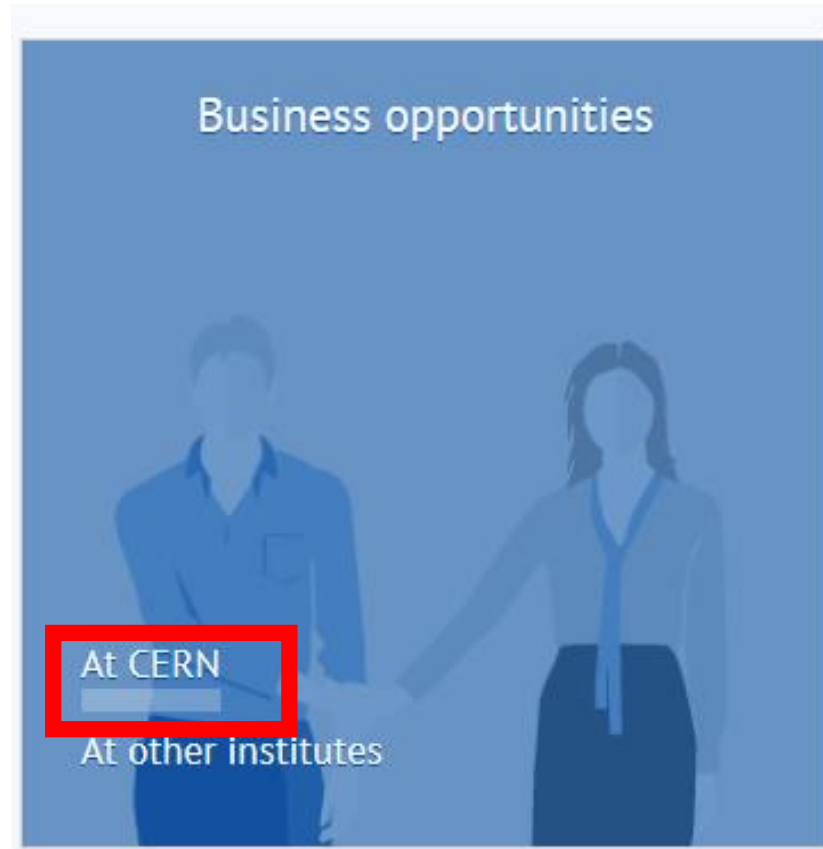

Accelerating Science

Procurement Website



Procurement Website

| Search Menu | | Links Menu | |
|--|--|-----------------------------------|--|
| Type of Contract: <input type="text" value="All"/> | Market Survey dispatched: <input type="text" value="All"/> | Reference: <input type="text"/> | Call for Tenders scheduled for dispatch: <input type="text" value="All"/> <input type="text" value="All"/> |
| Activity Code: <input type="text"/> | Description and/or Specific Condition: <input type="text"/> | Requirement: <input type="text"/> | Commercial contact: <input type="text" value="All"/> |
| Cost Range: <input type="text" value="All"/> | Publication Date: <input type="text" value="From"/> <input type="text" value="To"/> dd-mm-yyyy | | |
| <input type="button" value="Search"/> <input type="button" value="Reset"/> | | | |

| Publication Date | Type of Contract | Reference | Requirement (Activity Code) | Description/Specific Condition | Cost Range | Market Survey scheduled for dispatch | Contacts and Interest in being contacted / Market Survey Documents | Invitation to Tender scheduled to dispatch |
|------------------|------------------|---|--|---|------------|--------------------------------------|--|--|
| 01-10-2019 | Supply |  MS-4574/SMB/LHC | Supply of roof renovation works of building SM18 (01020304) | CERN intend to place a contract for the roof renovation works ... Interested firms shall have a proven experience and competence in the ... <input type="button" value="Read More"/> | B | Fourth quarter 2019 | To express an interest please send an e-mail to procurement.service@cern.ch Technically: D. Rodriguez Gomez Commercially: S. Magnan | Fourth quarter 2019 |
| 26-09-2019 | Supply |  MS-4565/IT | Supply of a turnkey data centre on CERN's Prévessin site, in France (01020101 , 01030103 , 01900100 , 01900300 , 02030200 , 02700100 , 03040100 , 04900600 , 13040600) | CERN intends to place a contract for supply of a ... Interested firms shall have a proven experience and competence in design, ... <input type="button" value="Read More"/> | D | Fourth quarter 2019 | To express an interest please send an e-mail to procurement.service@cern.ch Technically: W. Salter Commercially: A. Horridge | First quarter 2020 |
| 18-09-2019 | Supply |  IT-4557/EN | Supply, installation, testing and commissioning of a heat recovery station at Point 8 of LHC (France) (01030302) | CERN intends to place a contract for the supply, installation, testing ... Interested firms shall have a proven experience and competence in the ... <input type="button" value="Read More"/> | A | Refer to MS-4394/EN | To express an interest please send an e-mail to procurement.service@cern.ch Technically: P. Pepinster Commercially: B. Jenssen | Fourth quarter 2019 |
| 13-09-2019 | Supply |  MS-4541/EN | Supply of optical fibre cables (08040300) | CERN intends to place a framework contract for the supply of ... Interested firms shall have proven experience and competence in the production ... <input type="button" value="Read More"/> | A | Fourth quarter 2019 | To express an interest please send an e-mail to procurement.service@cern.ch Technically: S. Merolj Commercially: B. Jenssen | Second quarter 2020 |
| 02-09-2019 | Supply |  MS-4567/EN/HL-LHC | Supply of PXIe High Availability Chassis for the LHC Collimators controls upgrade (03040700) | CERN intends to place a contract for the supply of ... Interested firms shall have a proven experience and competence in the ... <input type="button" value="Read More"/> | A | Fourth quarter 2019 | To express an interest please send an e-mail to procurement.service@cern.ch Technically: P. Peronnard Commercially: F. Bonthond | Fourth quarter 2019 |

Procurement Website

Procurement and Industrial Services Group

Doing business with CERN

Doing Business with CERN CERN Personnel Industrial Liaison Officers Group Members

Doing business with CERN

Business opportunities

High Luminosity LHC project

Accelerating Science

Supplier Portal

Key reference documents

Who to contact

Procurement Website



The image shows a screenshot of the HL-LHC Industry Procurement Website. The top navigation bar is dark blue with white text. On the left, it says "CERN Accelerating science". On the right, there are links for "Sign in" and "Directory". Below this, the "HiLumi HL-LHC PROJECT" logo is on the left, followed by the text "HL-LHC Industry". The main navigation menu is a dark blue bar with white text, containing "HOME", "ABOUT", "PROCUREMENT", "TENDERING", "TIMELINE", "EVENTS", and "ILOS". The "PROCUREMENT" and "ILOS" links are highlighted with red boxes. Below the navigation bar is a large photograph of a piece of equipment, the TANB (New HL-LHC Neutral Beam Absorber). The photograph shows a white cylindrical component with various cables and connectors. A label on the equipment reads "ANB-260-500-091-A". A blue text box in the bottom left of the photo says "TANB" and "New HL-LHC Neutral Beam Absorber". A vertical photo credit on the right edge of the image reads "(Photo: Miguel Lino Dos Santos - CERN)".

CERN Accelerating science

Sign in Directory

HiLumi
HL-LHC PROJECT

HL-LHC Industry

HOME ABOUT **PROCUREMENT** TENDERING TIMELINE EVENTS **ILOS**

TANB

New HL-LHC Neutral Beam Absorber

ANB-260-500-091-A

(Photo: Miguel Lino Dos Santos - CERN)

Procurement Website



HL-LHC Industry

Website for HiLumi Procurement

Home

ILO Documents

Present Departmental Requests

Work Packages

Project Breakdown Structure List

Shopping Lists

Domains Of Activity

Activities To Work Packages

Recent

Shopping List WP18

Shopping List WP16

Shopping List WP13

Shopping List WP6B

Dear ILO this page gives you access to Purchasing statistics, to an space to exchange data on exper
Surveys and Invitation to Tender in preparation for HL-LHC. You will also find the list of HL-LHC cor

Do not hesitate to indicate us other views you would find interesting. You can always exchange info

Present Departmental requests

| ✓ | ID | Reference | WP | Title | Category | Date raised | Date needed | Status |
|---|----|----------------------|------|-----------------------------------|---------------------------|-------------|-------------------------|------------------|
| | 1 | DR-6286387/TE/HL-LHC | WP12 | Co-lamination for HL beam screens | ... 200.000 < x < 750.000 | 04.02.2016 | 01.09.2017 - 01.12.2017 | Process finished |
| | 2 | DR-6210212/TE | WP12 | UHV All metal gate valves | ... >750.000 | 17.11.2015 | 01.09.2016 - 31.08.2021 | Process finished |
| | 3 | DR-6262431/TE/HL-LHC | WP3 | MQXF, END SPACERS | ... 200.000 < x < 750.000 | 22.12.2017 | 14.01.2016 - 22.12.2017 | Process finished |
| | 4 | DR-6259143/TE/HL-LHC | WP3 | WP3 Q4 magnet QUACO | ... >750.000 | 12.01.2016 | 01.12.2016 - 01.02.2021 | Process finished |

Procurement Website

| | | | | | | | | |
|-----|----------------------|-----|-------------------|-----|----------|------------|------------|----------------------|
| 183 | DR-7930265/TE/HL-LHC | WP7 | CLIQ series units | ... | >750.000 | 20.08.2019 | 21.12.2023 | MS Under preparation |
|-----|----------------------|-----|-------------------|-----|----------|------------|------------|----------------------|

| | |
|------------------|---|
| Title | CLIQ series units |
| Reference | DR-7930265/TE/HL-LHC |
| WP | WP7 |
| Category | >750.000 |
| Date raised | 20.08.2019 |
| Date needed | 21.12.2023 |
| Long Description | <p>This purchase concerns the supply of 8 (STRING) + 24 (HL-LHC) units of CLIQ (Coupling-Loss induced Quench) for the protection of the HL-LHC IT magnets</p> <p>Interested firms must have proven experience in:</p> <ul style="list-style-type: none"> - Assembly of racks with electrical & electronics components - Testing and handling of critical electronics & electrical equipment within the range of parameters of this application (~ 1000 VDC, ~ 40 mF, ~ 10 kA) - Handling metallized film capacitors in the parameter range of this application - Storage energy systems discharge into loads (resistive & inductive) - CE marking design oriented <p>The company selected shall comply with CERN Safety rules (available at the link: http://cern.ch/safety-rules) and the Swiss and French and European legislation, in particular:</p> <ul style="list-style-type: none"> - IS 23 Criteria and Standard Test Methods for the Selection of Electric Cables and Wires with Respect to Fire Safety and Radiation Resistance (2005). - IS 41 The use of plastic and other non-metallic materials at CERN with respect to fire safety and radiation resistance (2005) |
| Status | MS Under preparation |

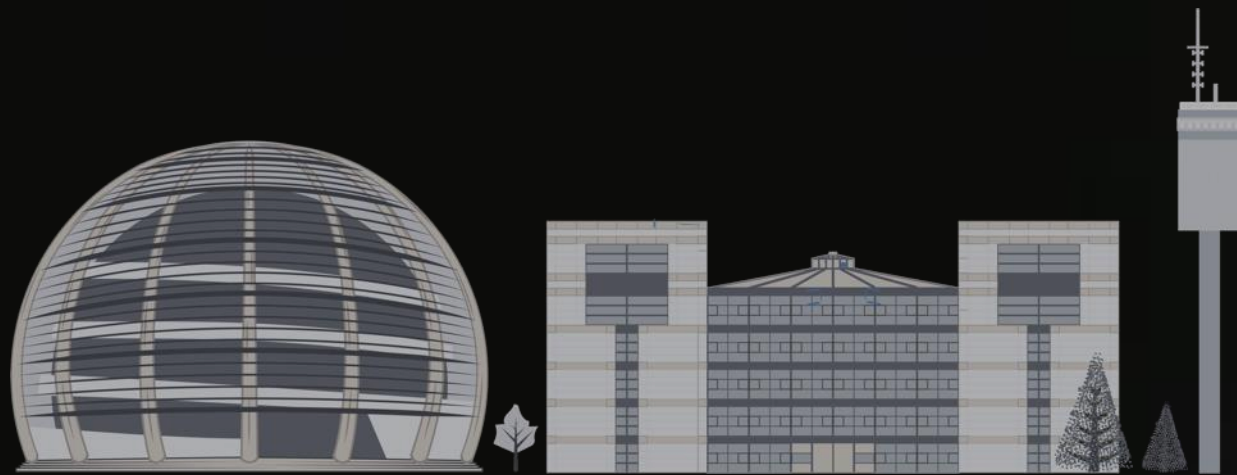

Upcoming Tenders

MS-4565/IT

Supply of a turnkey data center on Preveessin site

Requirement:

Supply of a turnkey **data centre** on CERN's Préveessin site, in France (01020101, 01030103, 01900100, 01900300, 02030200, 02700100, 03040100, 04900600, 13040600)

Description and/or Specific Condition:

CERN intends to place a contract for the supply of a **turnkey data centre** on CERN's **Préveessin** site, in France, including the **design, construction, operation and maintenance**. The data centre shall provide an initial capacity of **4 MW** and be capable of staged upgrades to at least **12 MW**. It shall include all technical infrastructure systems as well as racks, **excluding IT and networking equipment**. The contract is foreseen to be awarded in January 2021.

Interested firms shall have a **proven experience and competence in design, construction, operation and maintenance of data centres**. The proposed data centre should be based on an **existing design** which is already **operational**.

MS-4513/TE/HL-LHC

Design and supply of 76 units of 2kA Direct Current Current Transducers (DCCTs)

Requirement :

Design and supply of 76 units of 2kA **DCCTs** for the High-Luminosity Project ([02100900](#))

Description and Specific Condition:

CERN intends to place a contract for the design and manufacture of **76 bipolar voltage output DCCTs** with a nominal current rating of **2 kA** and a **12 hour stability** of less than 1 part in 10^6 (ppm)

Interested firms shall have testing and **calibration facilities to less than 10-ppm absolute accuracy**, and be experienced in supplying high precision DCCT systems.

MS-4541/EN

Supply of Optical fiber cables

Requirement :

Supply of **optical fibre cables** (08040300)

Description and Specific Condition:

CERN intends to place a **framework contract** for the supply of optical fibre cables (both **single mode and multimode** optical fibre cables, and totally approximately **300 km**) meant to be **pulled** or **air-blown** in a dedicated optical fibre infrastructure.

Interested firms shall have proven experience and competence in the **production of optical fibre cables**.

MS-4561/SMB

Supply of construction works

Requirement :

Supply of the construction works for a **new building** for the heat recovery station at point 8 on the French part of CERN. (01010300, 01020200, 01020300, 01020400)

Description and Specific Condition:

CERN intends to place a contract for the construction works for a new building **(15 x 6 ml)** for the heat recovery station at point 8 on the **French part of CERN**, including **reinforced concrete** (100m³), road works, steel construction, cladding (250m²), roofing and waterproofing (90m²), external door, and metal floor (90m²).

Interested firms shall have a proven experience and competence in the field of civil engineering works and construction of **industrial buildings**.

MS-4558/SMB

Supply of Personal Protective Equipment

Requirement :

Supply of **personal protective equipment** (10080100, 10080200, 10080300, 10080400, 10080500, 10080600)

Description and Specific Condition:

CERN intends to place a **three-years contract** for the supply of **personal protective equipment** on the CERN site including work and protective clothing, head, eye, ear, hand, foot and body protections.

Interested firms shall be able to prove experience and competence in the supply of personal protective equipment, **including on stock, follow-up service for repairs and replacements.**

MS-4541/EN

Supply of centrifugal water pumps

Requirement :

Supply of **centrifugal water pumps** (01030303)

Description and Specific Condition:

CERN intends to place a five-year **blanket purchase contract** for the supply of centrifugal water pumps in the flow range between **1 and 1000 m³/h** and a **manometric height between 20 and 200 m**. The quantity of pumps needed per year is estimated to be around 15 with an average flow of 150 m³/h and a manometric height of 60 m. The above estimated quantities are given for information only, and do not constitute any commitment from CERN.

Interested firms shall have **proven competence and experience of at least ten years in the field of designing, manufacturing and testing centrifugal water pumps** in the flow range between 1 and 1000 m³/h and a Manometric height between 20 and 200 m.

MS-4561/SMB

Supply of technical services for exhibitions, events and educational laboratories

Requirement :

Supply of **technical services for exhibitions**, events and educational laboratories on the CERN site, and outside CERN for travelling exhibition deployment (12070300, 12070400).

Description and Specific Condition:

CERN intends to place a contract for the provision of technical services for exhibitions, events and educational laboratories on the CERN site and as well for occasional travelling exhibitions outside CERN. The services include **maintenance of 500 pieces of audio-visual and IT equipment** on two permanent exhibitions and ten visit points at the CERN sites in **Switzerland and France**, as well as events held at CERN and technical support for **travelling exhibitions**. The contract is foreseen for an initial period of three years, renewable by CERN.

Interested firms shall have **proven experience** and competence in the domains of **exhibition services**, IT services and/or facility management services.

HL-LHC Procurement Challenges ahead

End Spacers manufactured in G11 NEMA material for D2

Requirement : Tendering foreseen by 2020

- High precision machining
- Complex shapes
- Material to be acquired by the manufacturer

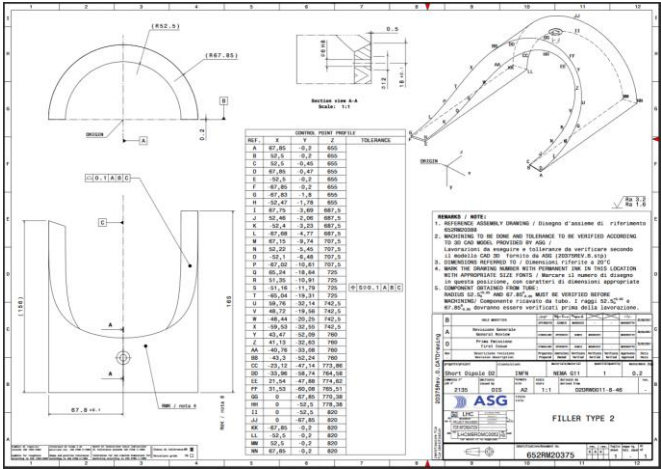
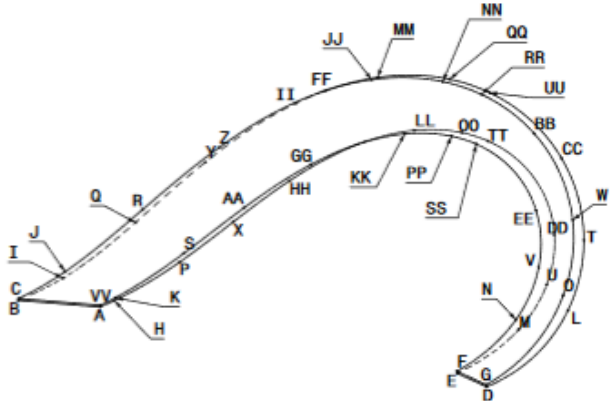
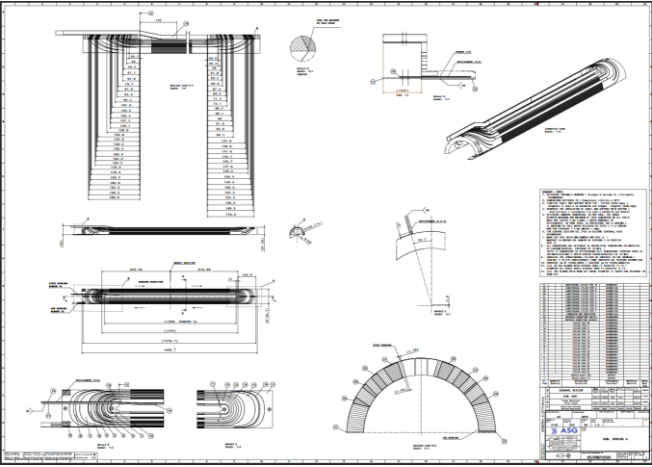
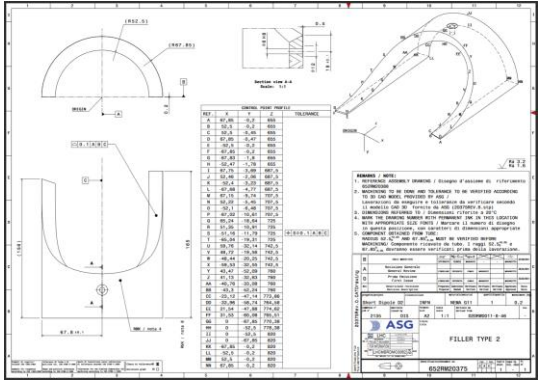
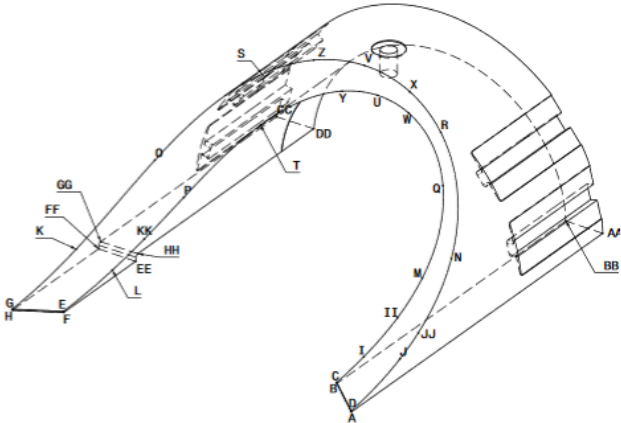

Wedges for D2

Requirement : Tendering foreseen by 2020

- High precision manufacturing
- Tight tolerances
- Made of OFE Copper extruded and cold drawn

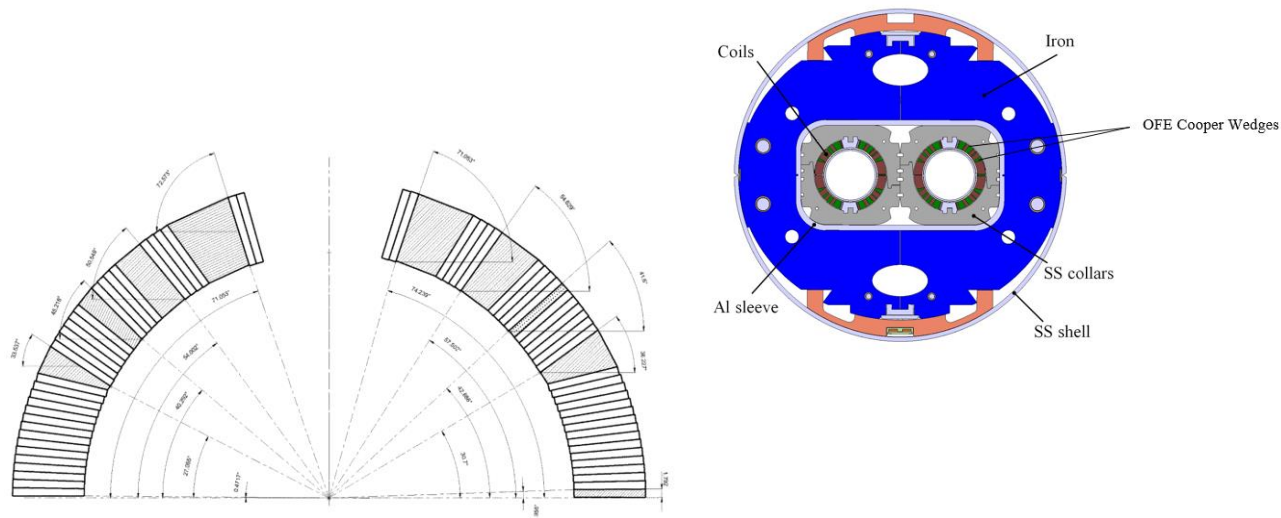

NOTE

- 1) All edges have a fitting radius $R = 0.3 \text{ mm}$
- 2) The roughness of each surface will have to be included in the values of $Ra = 1.6$ and $Ra = 3.2$

| Position | Drawing # | Checked | Date | Rev | Description | Degree of Accuracy | Status | Release |
|----------|-----------|---------|------------|-----|-------------|--------------------|--------|---------|
| | | | 2010-03-10 | 1 | | 1 | 3.000 | 0/0 |

| Drawing # | Equipment | Group | Drawing # |
|-----------|-----------|-------|------------------|
| | | F | MBR/DP_DWG_00100 |

Coupling-Loss Induced Quench (CLIQ)

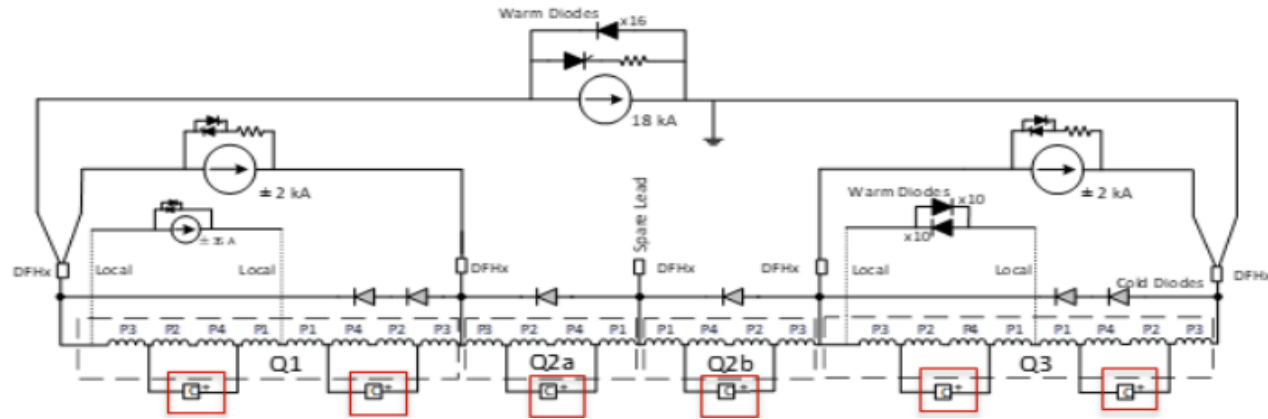

Requirement :

- Protection of superconducting magnets after a quench
- Assembly of racks with electrical & electronics components
- Integration and testing of critical electronics & electrical equipment (~ 1000 VDC, ~ 40 mF, ~ 10 kA)
- Handling metallized film capacitors in the parameter range of this application
- Storage energy systems discharge into loads (resistive & inductive)

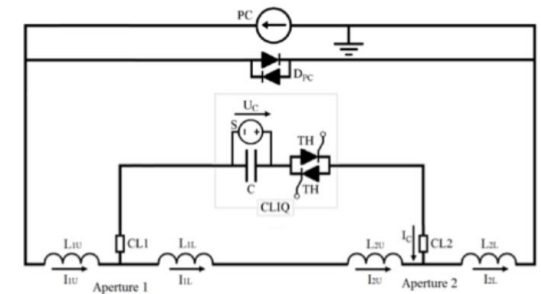

Capacitors for CLIQ for superconducting magnet protection

Requirement :

- Long life (>20 years at 25 C), Energy will be stored and released a maximum of 5 times per day and 200 times per year, usually into an inductive load of ~ 4 mH with a peak current of ~ 3 kA
- Capacitance of ~ 40 mF
- Withstand a surge current up to 100 kA



Cryogenic Cables for Beam Position Monitors

Requirement :

- ~ 300 cables needed (proto, series, spares)
- Cables to withstand cryogenic temperatures (~ 5K)
- SiO₂ Coaxial RF Cables

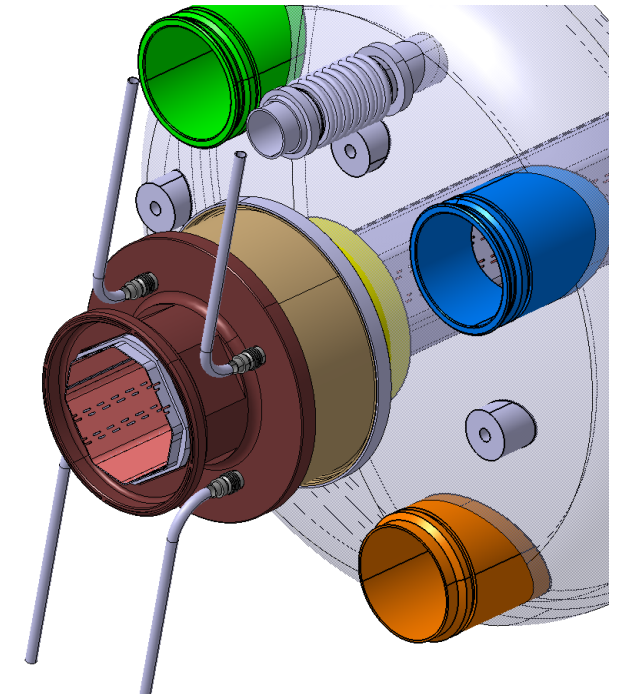

Transport equipment

Requirement :

- Customized vehicles for installation of the magnets in the LHC
- Customized forklift for FeedBoxes
- Trailer and transfer system for Absorber (TAXN)

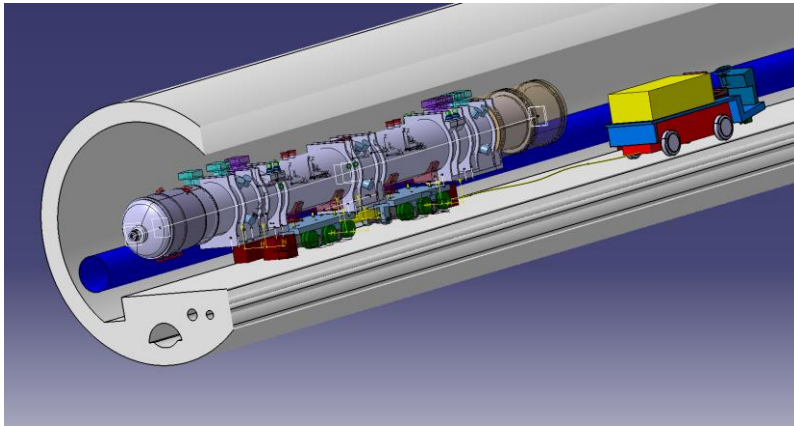

Equipment for the new HL-LHC Electrical Buildings

Requirement :

- Power Transformers
- MV Cubicles
- Power Cables (fire and radiation resistance)
- LV Switchboards and electrical protections



Electrical Substation LHC P5 (CMS)

Requirement :

- 66 / 18 kV substation
- 38 MVA transformer
- Modification of LHC P6 electrical

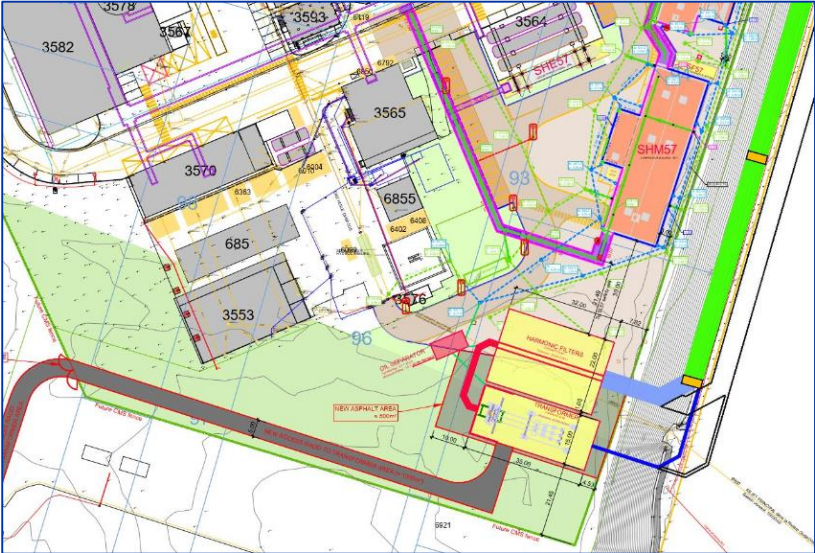
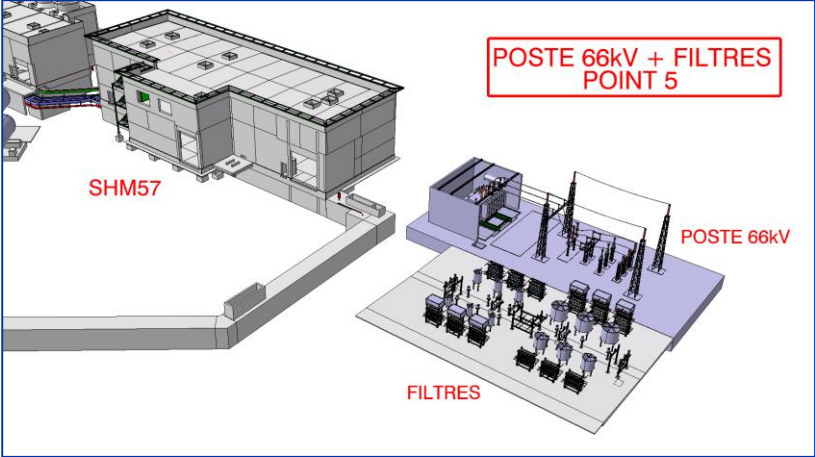
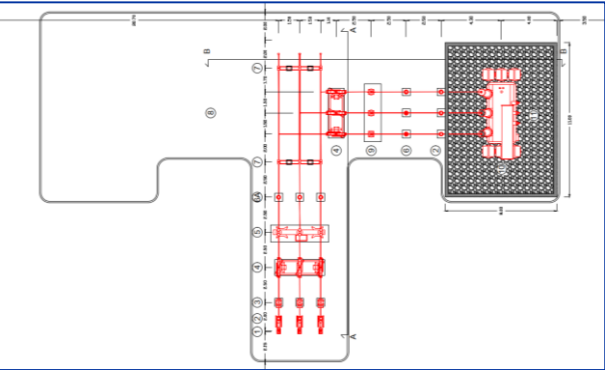

Cooling and ventilation for HL-LHC Project

Requirement :

- Design, supply, installation, testing and commissioning of surface and underground ventilation systems



Cooling and ventilation for HL-LHC Project

Requirement :

- Design, supply, installation, testing and commissioning of:
 - chilled and mixed cooling water production systems
 - compressed air and heating circuit
 - primary cooling water systems
 - secondary demineralised
 - raw water cooling circuits for the HL-LHC Project





Successful Bidders & Contractors

Successful Bidders & Contractors

- **100 % of the successful bidders**
 - Were registered in CERN Database
 - Made an offer
- **Often small – medium sized and flexible firms**
- **Full understanding of specifications**
 - Exceeding specifications will be too expensive
 - Take into consideration test and documentation costs
- **Best offer directly**
- **Agreed on the General Conditions of CERN Contracts**
 - GCCC are standards, and light compared to many private companies

Three notable examples of successful bidders offering goods originating from Slovenia

- ELGOLINE LTD
- CONTAINER DOO
- ZUSTAL
- PARTICULARS

ELGOLINE LTD

**Podskrajnik 34,
SI-1380 CERKNICA**

End-Cap Bus Tapes / ATLAS

Bus tapes – flexible circuits

- Joint Development Project between Elgoline Ltd. & Jožef Stefan Institute
- Route to the End cap Petal: power (HV and LV), Data, Ground, Clock, and control to silicon strip modules on a end cap petal
- Cu/Kapton©, double-sided, dimensions 65x35 cm²
- The circuit has to be radiation hard up to 660 kGy

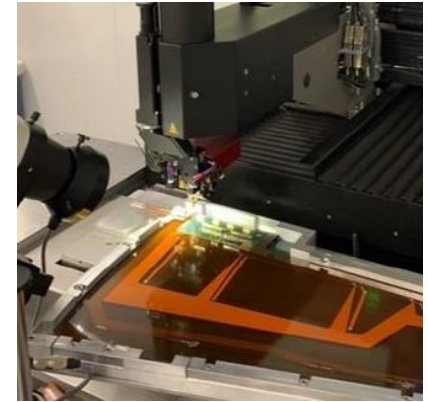
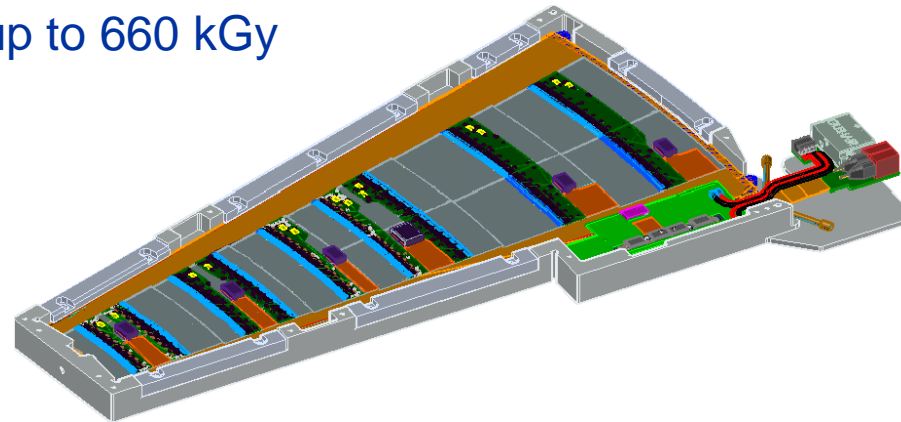

CONTAINER D.O.O.

**Bezigrajska cesta 6,
SI-3000 CELJE**

Special containers for transport of nuclear materials

Container certified «Type A»



Container certified «IP2»



Special container certified «IP2»

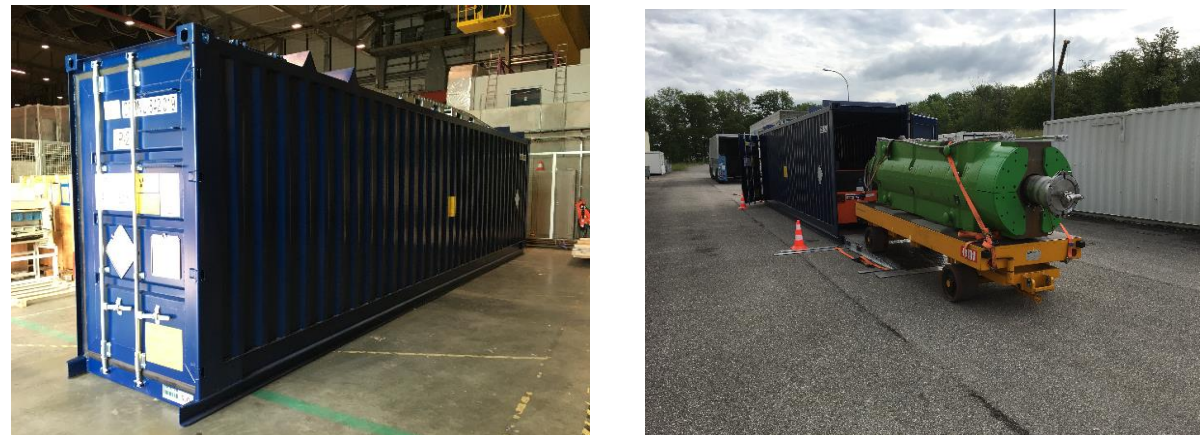

ZustAI

Raceva 14, SI-4226 ZIRI

Mechanical parts for automatized trolleys in radioactive environment

- Manufacturing of a total quantity of 34 mechanical parts for automatized trolleys to be used in radioactive environment
- Parts in stainless steel 304L and brass

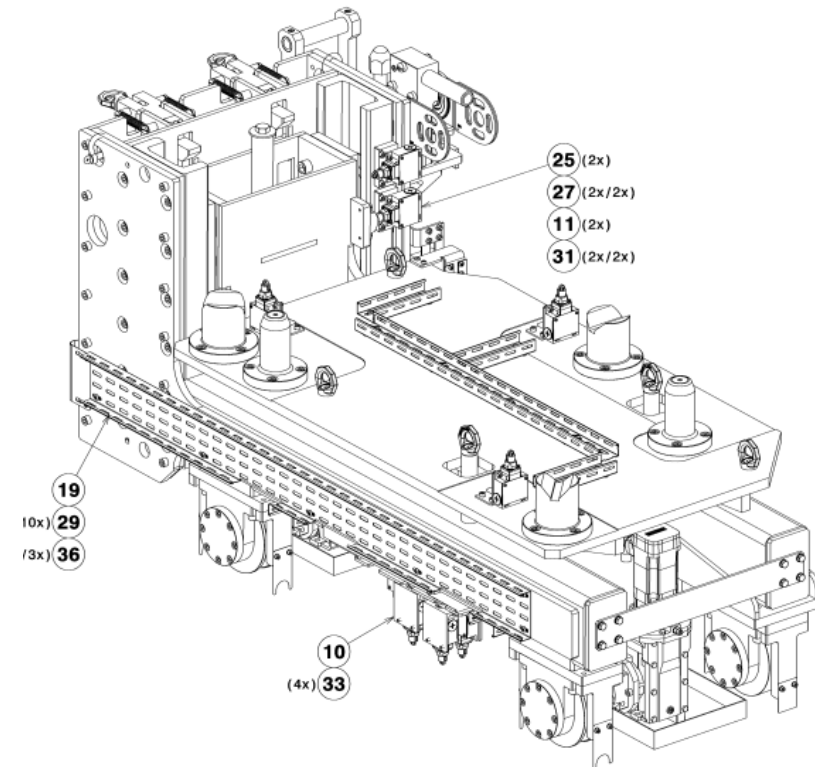
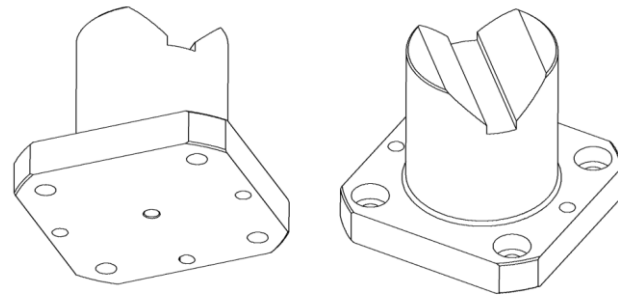

PARTICULARS

Dragomelj 154,
SI-1230 DOMZALE

Sensor characterization with Laser

Characterizations of Pixel detector prototypes

Edge-TCT (Transient Current Technique) employs a LASER supplied by Particulars to induce e-h pairs in the silicon

- 3 axis beam focusing (beam spot 5 μm) and positioning system (precision 1 μm)
- Infrastructure for testing irradiated samples in place (chiller, cold chuck, dry air, small volume)

Measurements of charge collection efficiency as a function of position, depletion depth and charge sharing across neighboring pixels

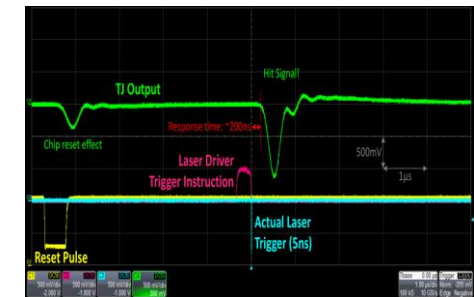
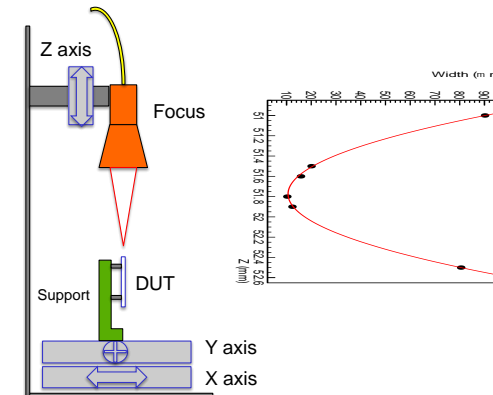
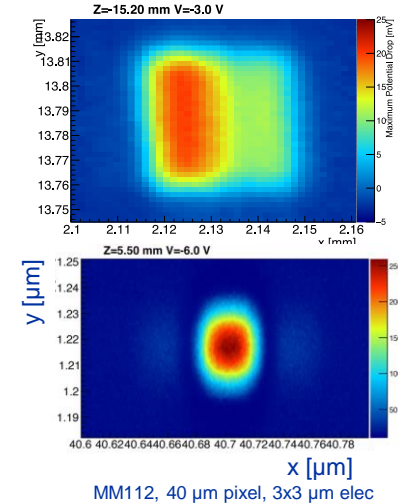

So, why not you ?

Thank you



home.cern