

LHeC



Possible Civil Engineering Layouts for :
(as discussed Chris Adolphsen, Max Klein, Frank Zimmermann 16 Oct 09)

- Pulsed machine 60 GeV
- 60 GeV Energy Recovery Linac
- 140 GeV pulsed Machine

LHeC



Pulsed machine 60 GeV

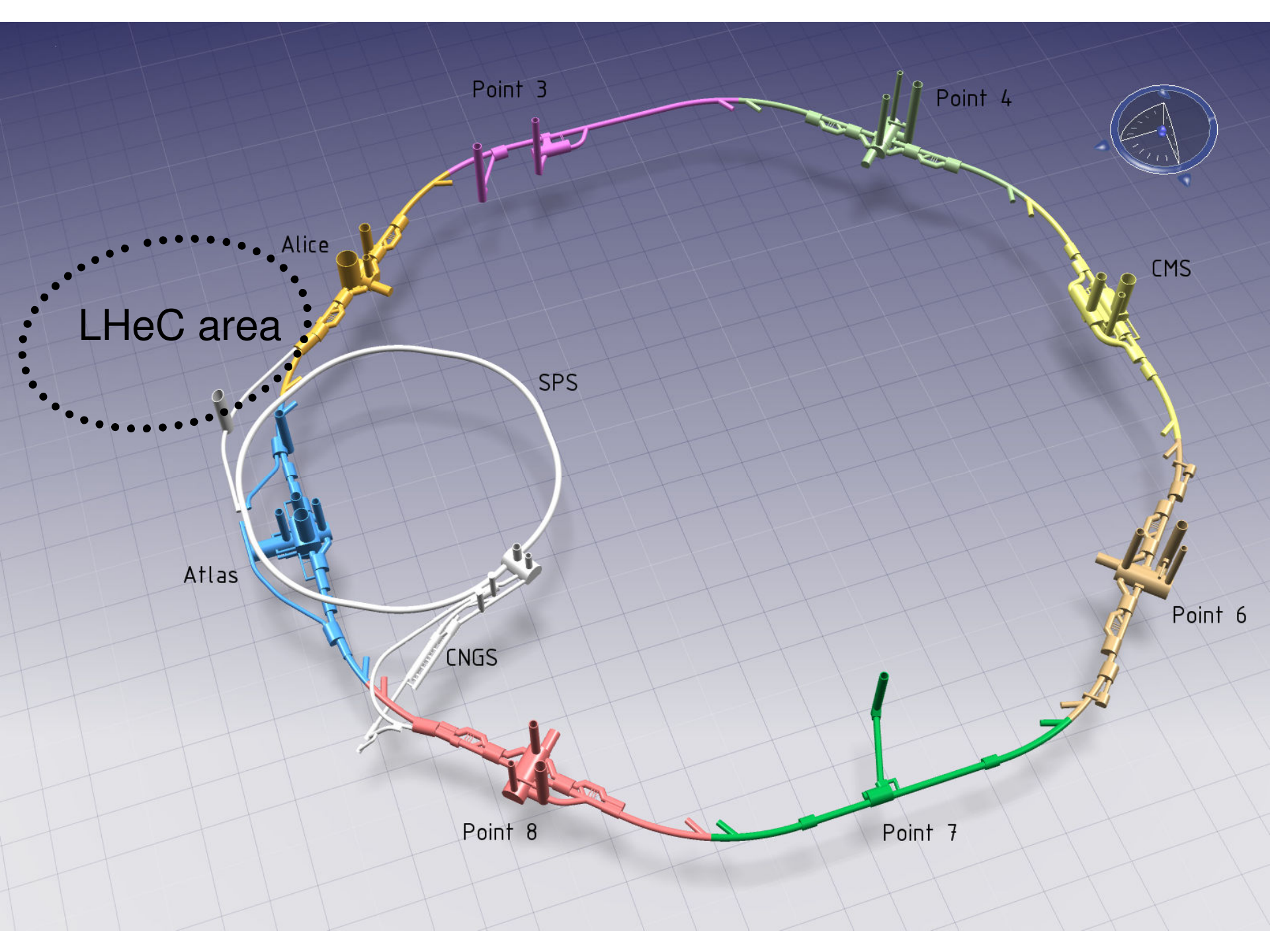

Assuming
'ALICE'
interaction
point

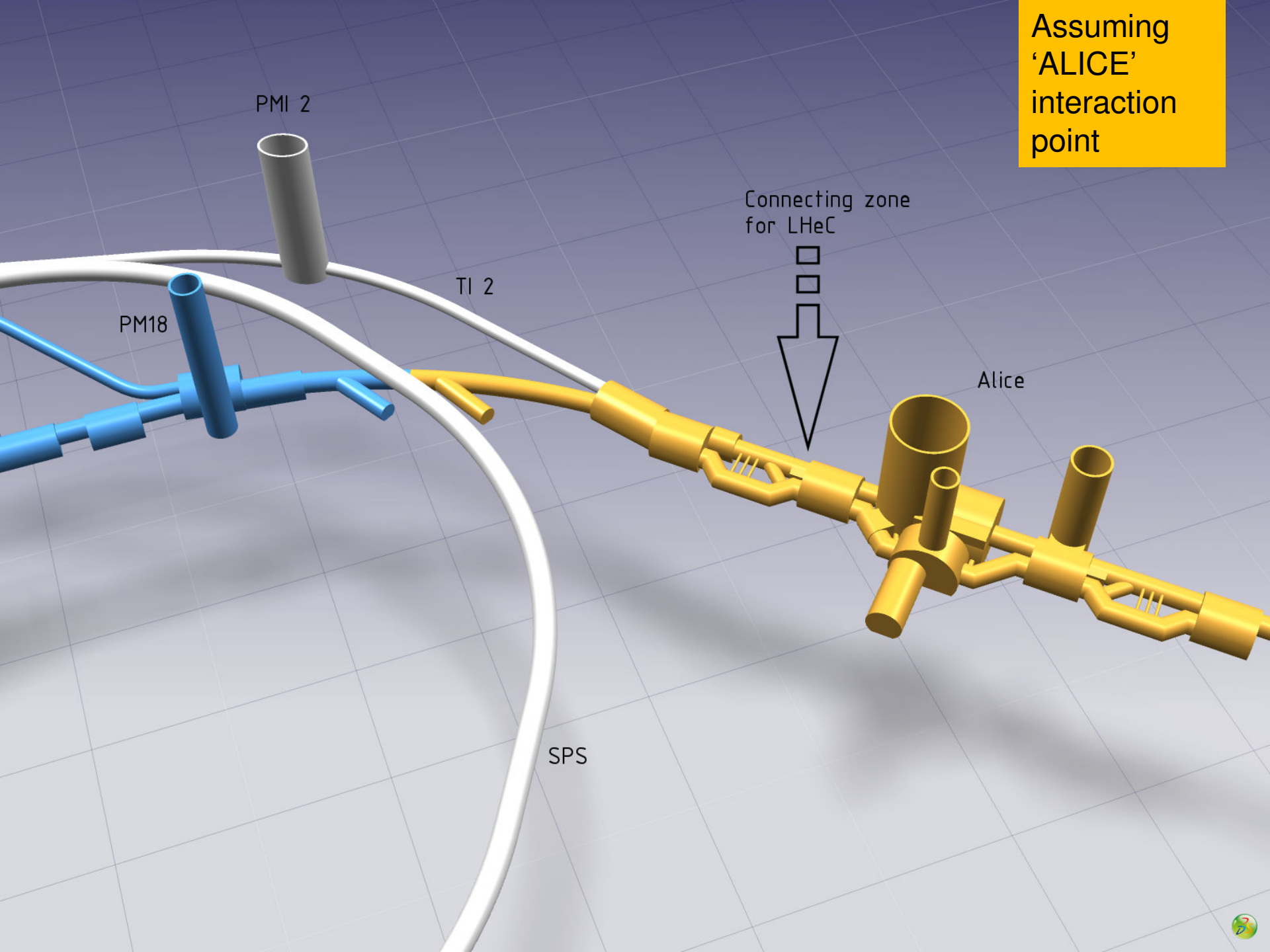

Pulsed machine 60 GeV - Top view

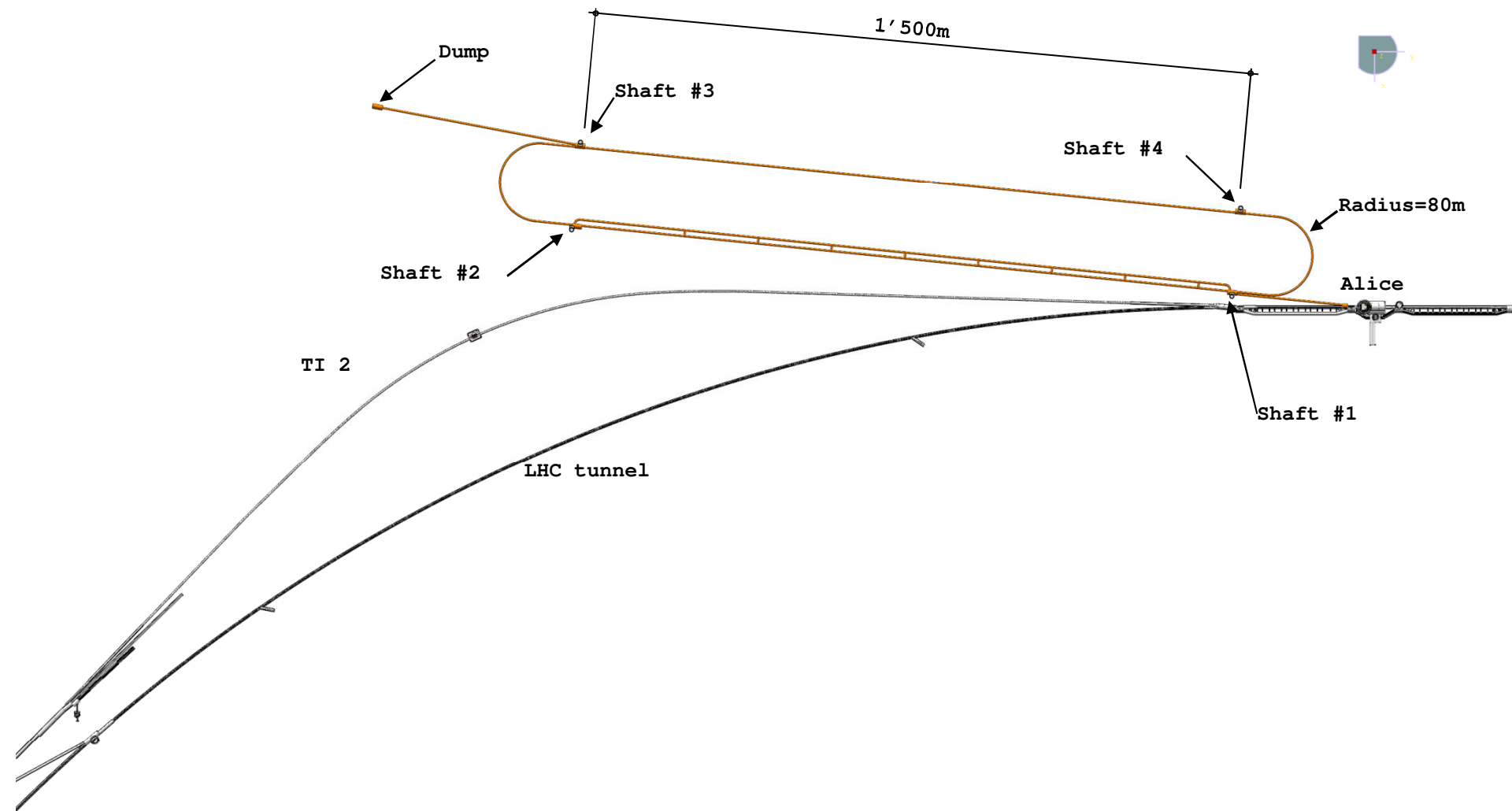

Pulsed machine 60 GeV - Top view

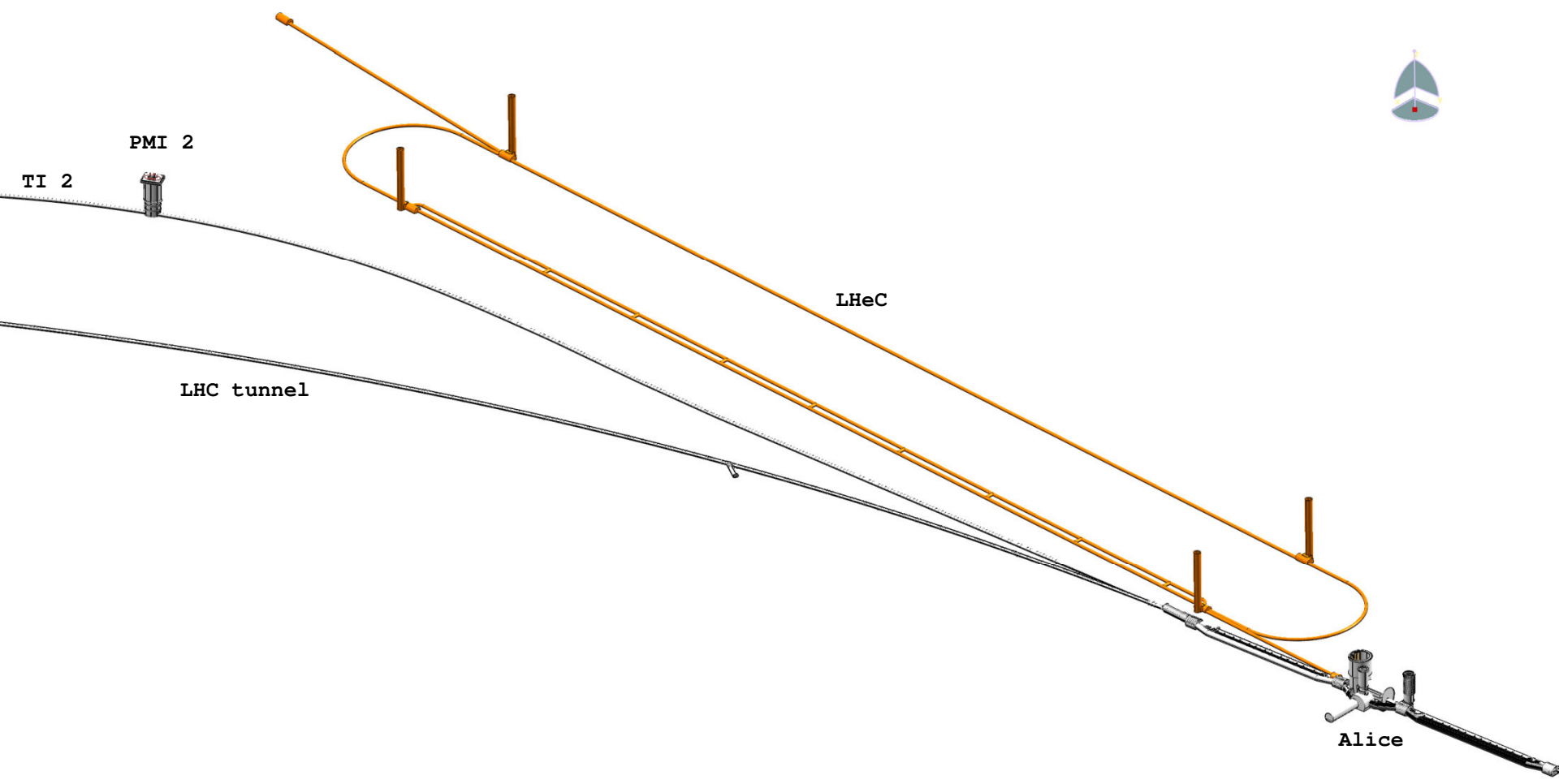

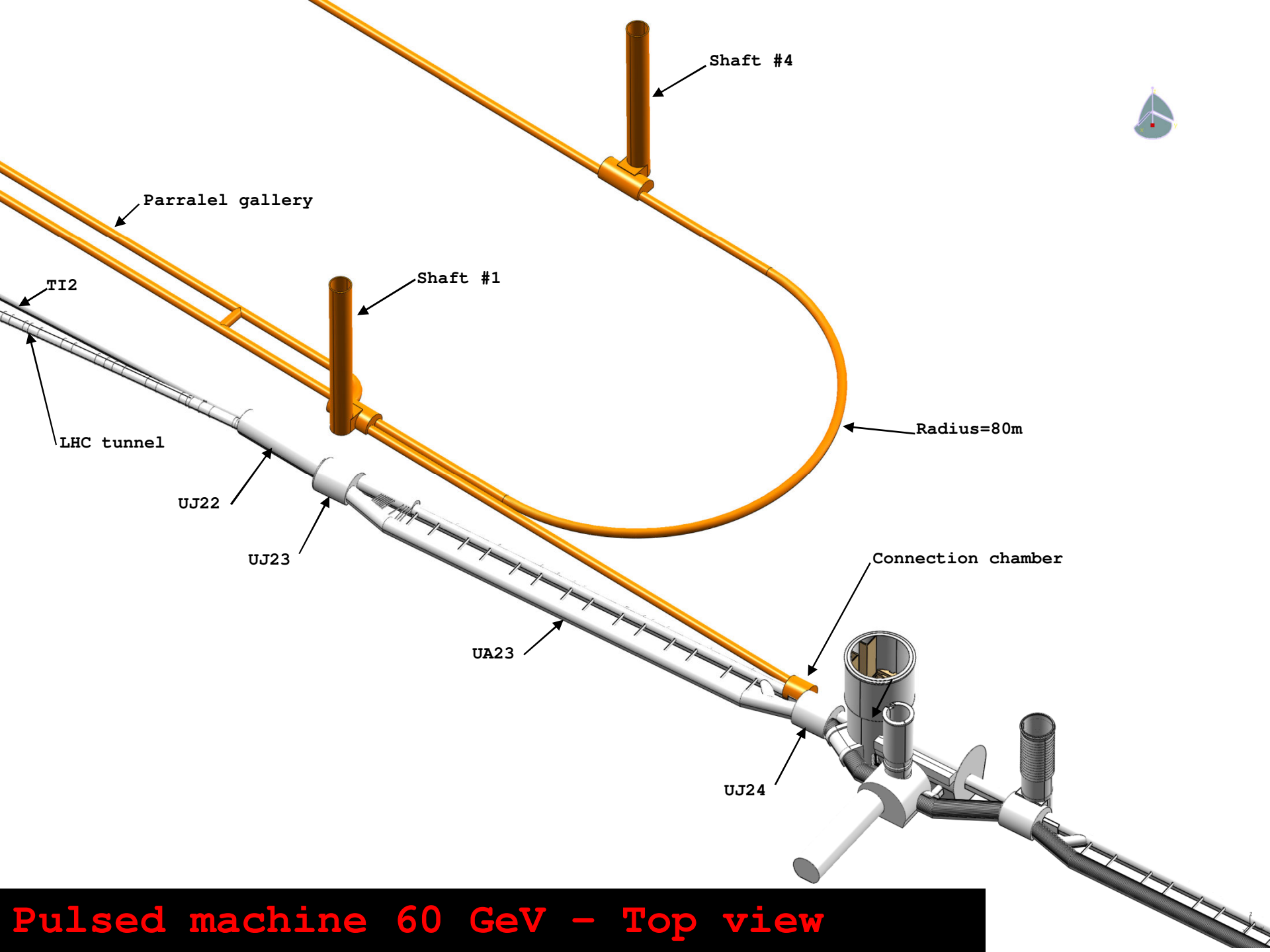

Pulsed machine 60 GeV - Top view

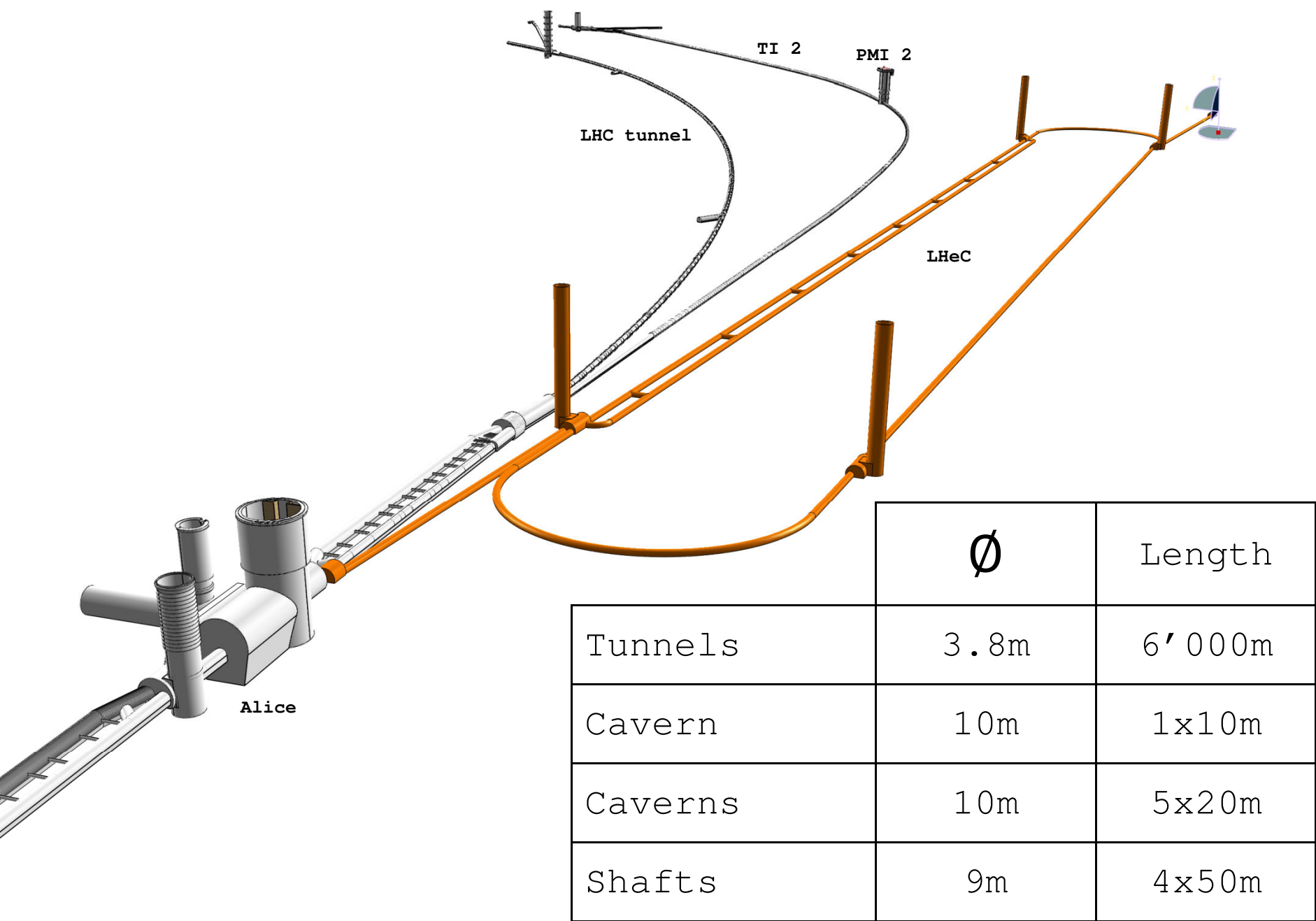

Pulsed machine 60 GeV - Top view

LHeC



60 GeV Energy Recovery Linac
Or 140 GeV pulsed Machine

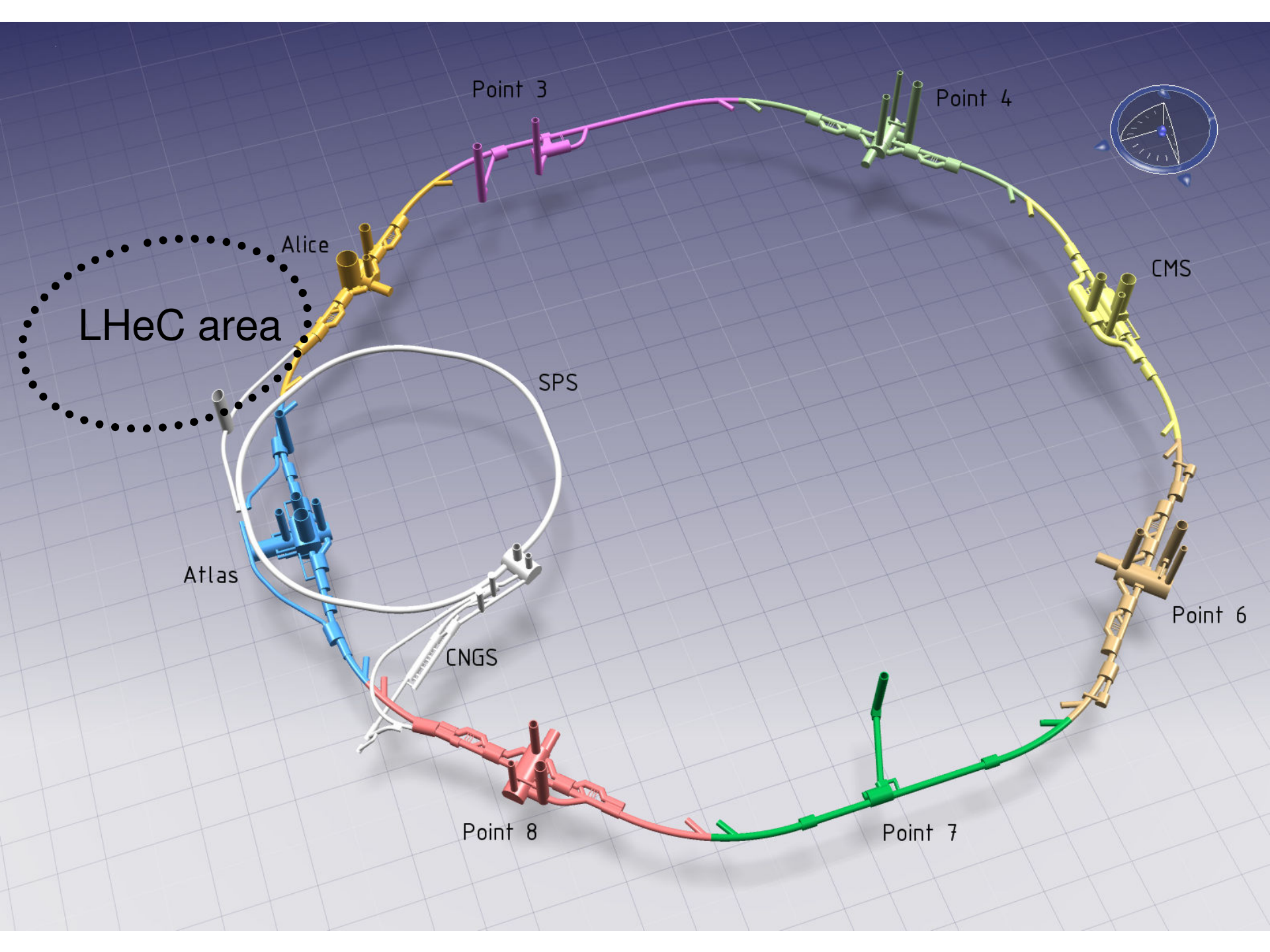

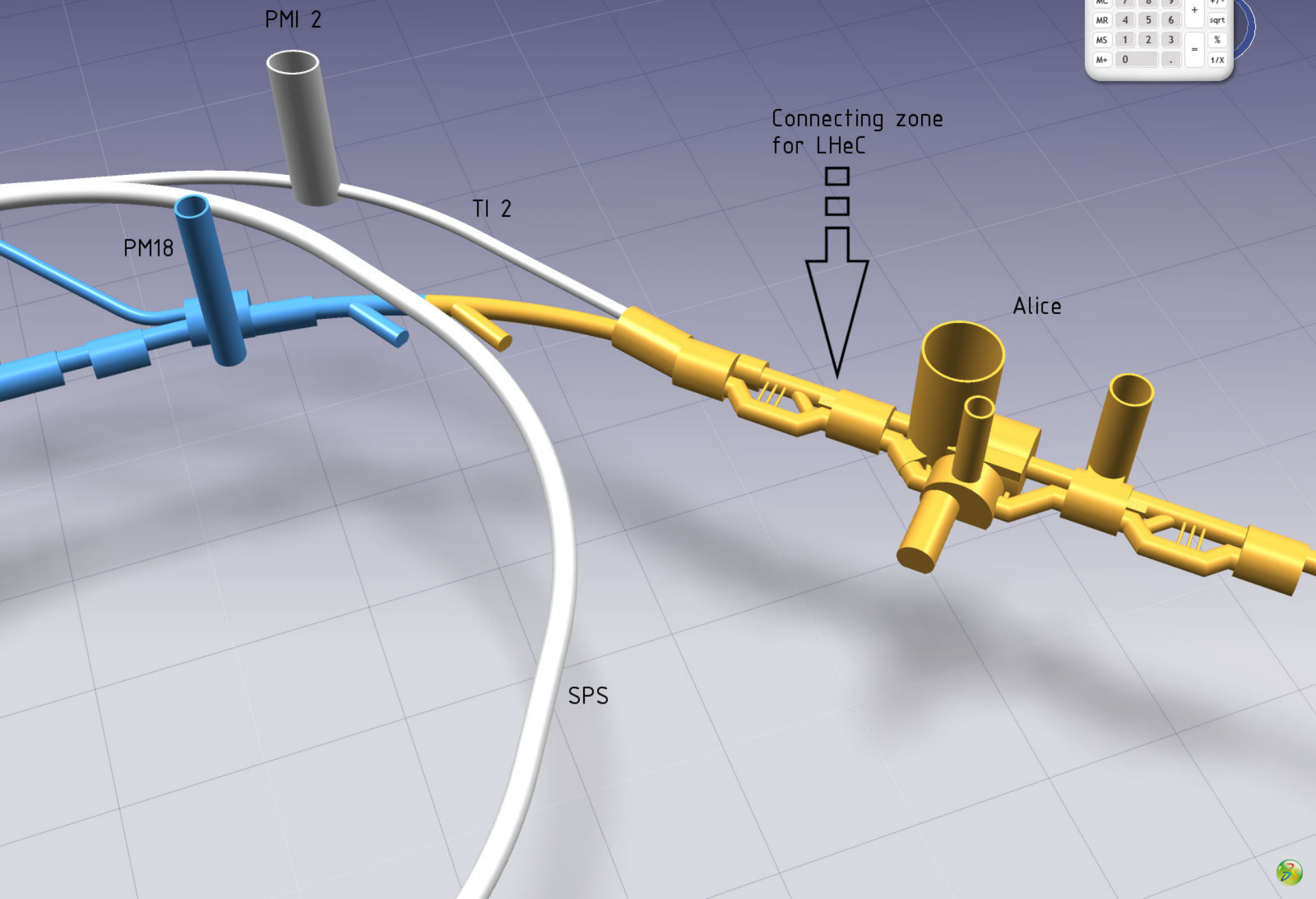

60 GeV Energy Recovery Linac Or 140 GeV pulsed Machine

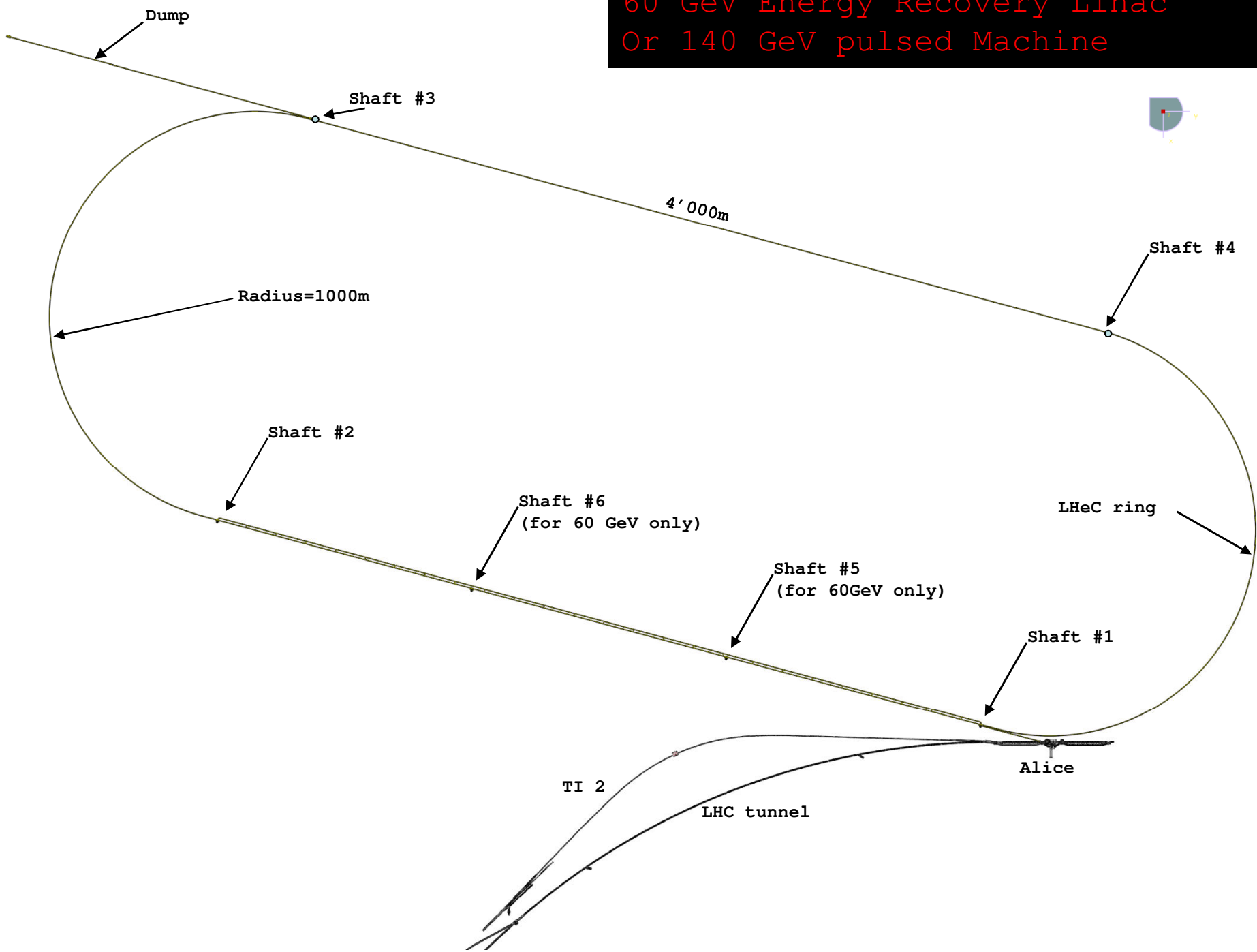

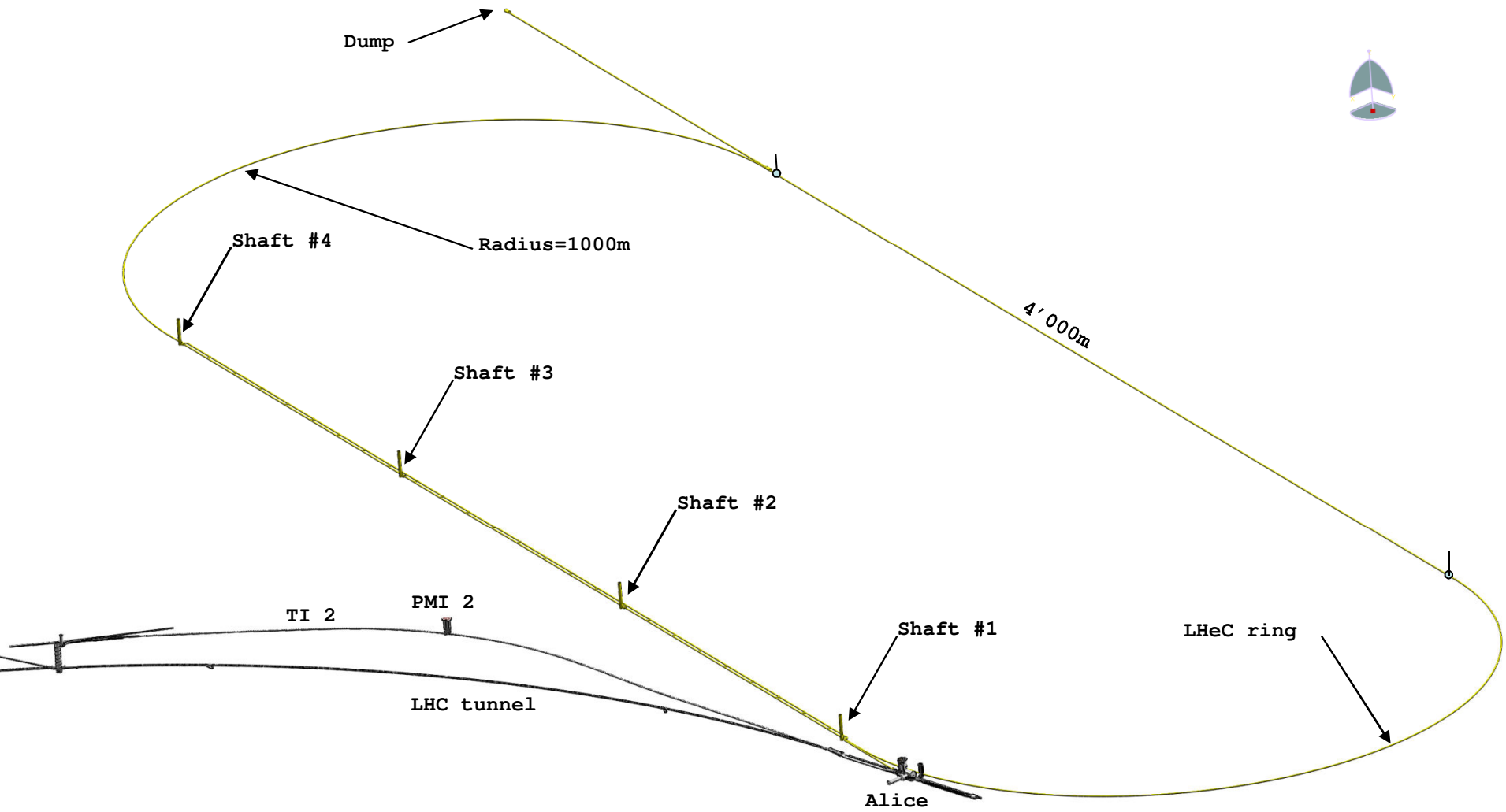

60 GeV Energy Recovery Linac = 2 shafts
 Or 140 GeV pulsed Machine = 4 shafts



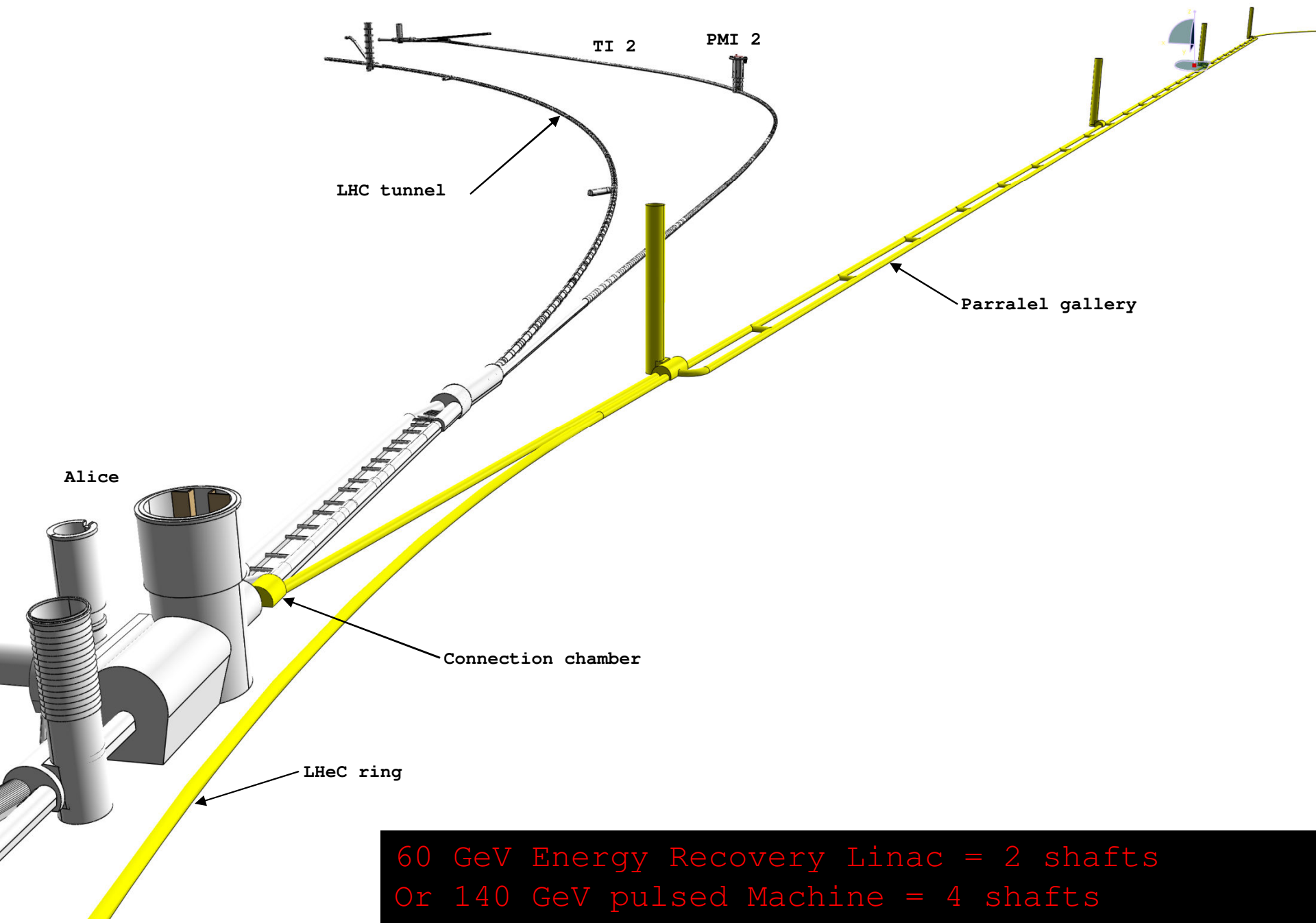

60 GeV Energy Recovery Linac = 2 shafts
Or 140 GeV pulsed Machine = 4 shafts

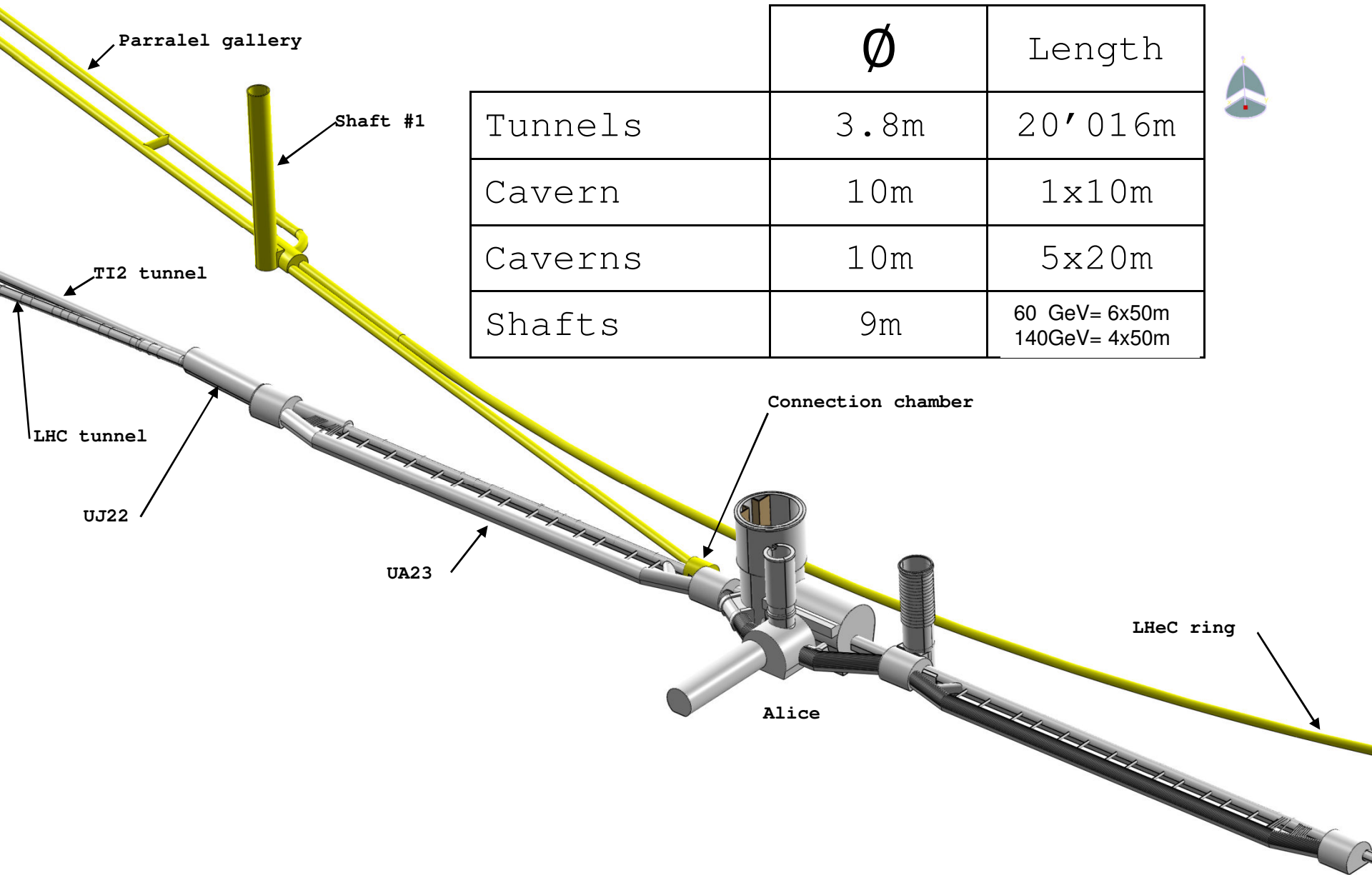

60 GeV Energy Recovery Linac
Or 140 GeV pulsed Machine