

Testing of an upgraded Low-Voltage Power Supply (LVPS) for the ATLAS TileCalorimeter front-end electronics

Ryan Mckenzie, Edward Nkadimeng, Thabo Lepota,
Nkosiphendule Niara, Roger van Rensburg, Charles
Sandrock, Bruce Mellado

Outline

- Location of LVPS brick.
- Why upgrade the LVPS brick?
- LVPS structure.
- LVPS production and testing.
- The initial tests station.
- Test parameters
- Sample tests and results.
- Summary

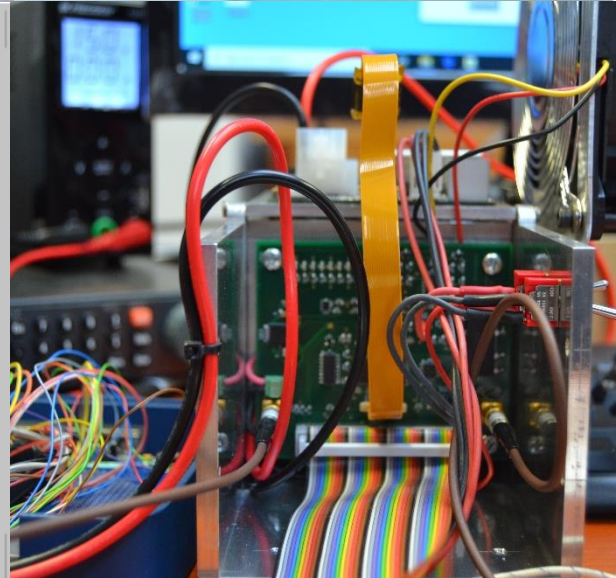
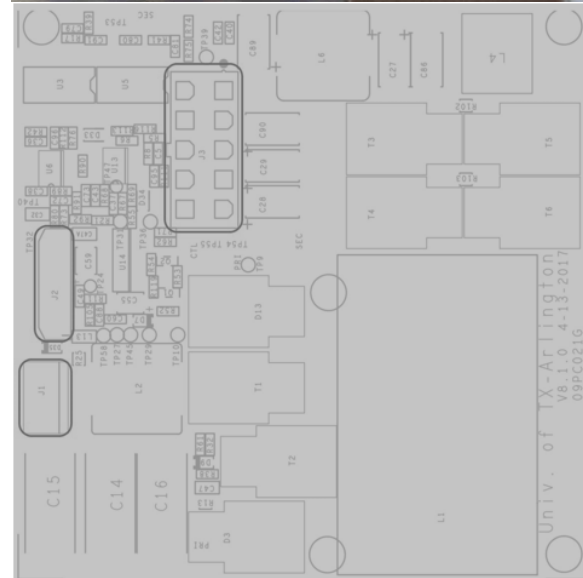
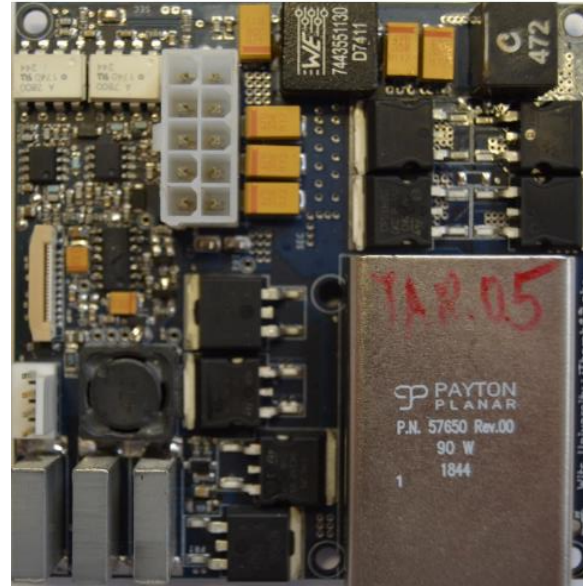

Location of LVPS Brick

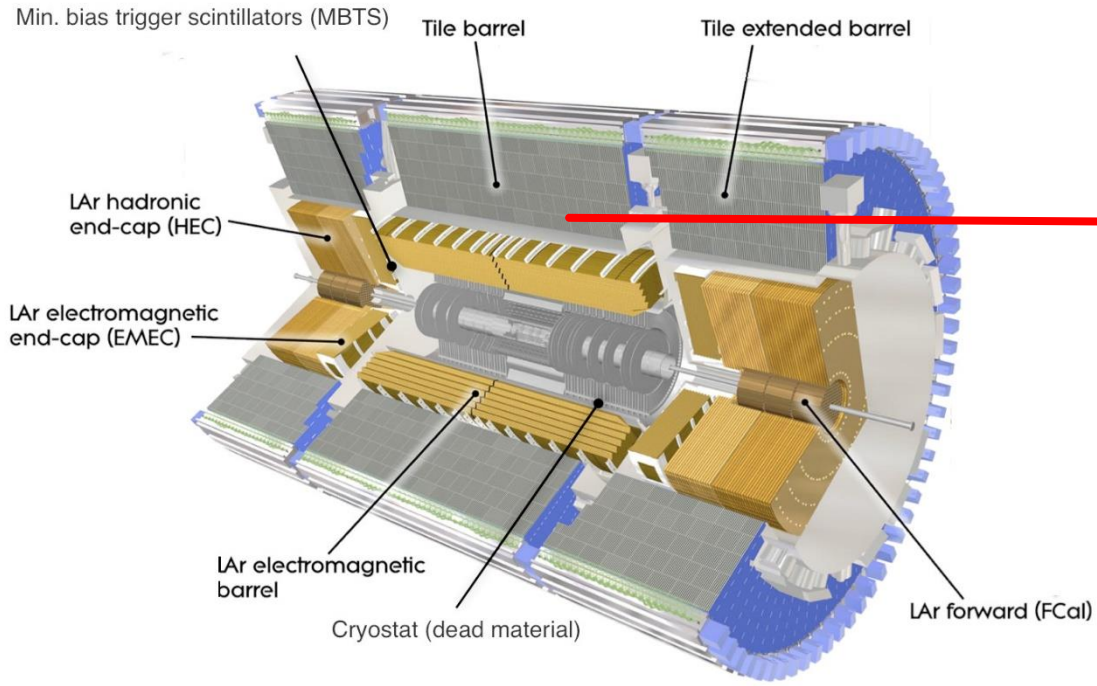

Tile Calorimeter

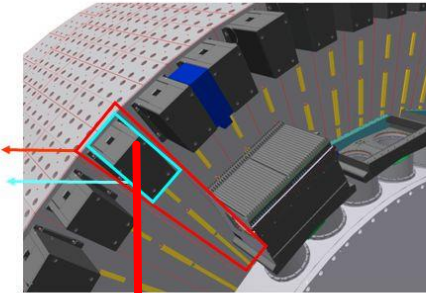

*Tilecal: one barrel (6m), 2 endcaps (3m).
- 256 drawers with front end electronics.
- 256 power supplies, 300W each.*

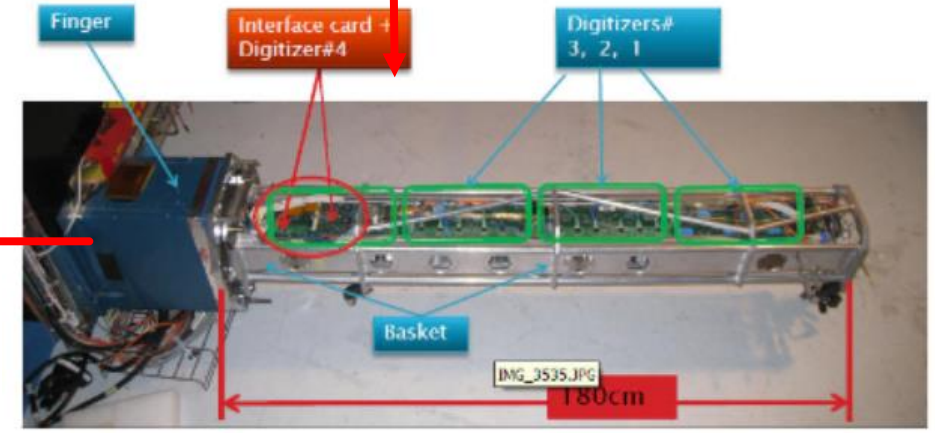
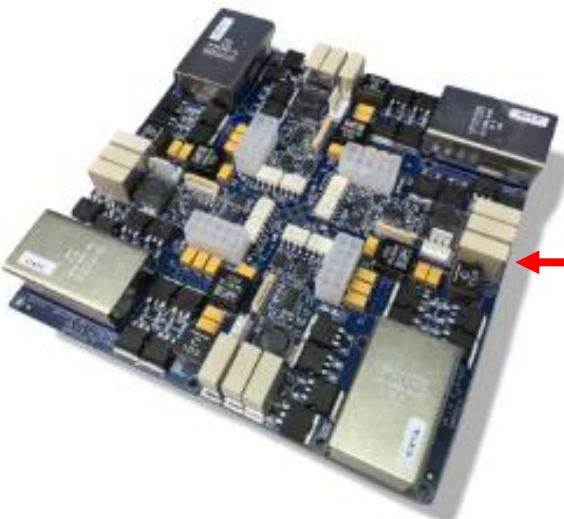

Why upgrade the LVPS brick?

- Current electronic components are reaching their end-of-life criteria and as such require replacement.
- Emphasis is placed on the reliability of the particle detector and by extension all of the subsystems and electronics therein
- LVPS's represent a single point failure in the readout system. - loss of data from a particular module.
- Limited access to LVPS on the order of once per year.
- Upgrade from a 2-stage to 3-stage power distribution system.

LVPS Brick Block Diagram and functional description

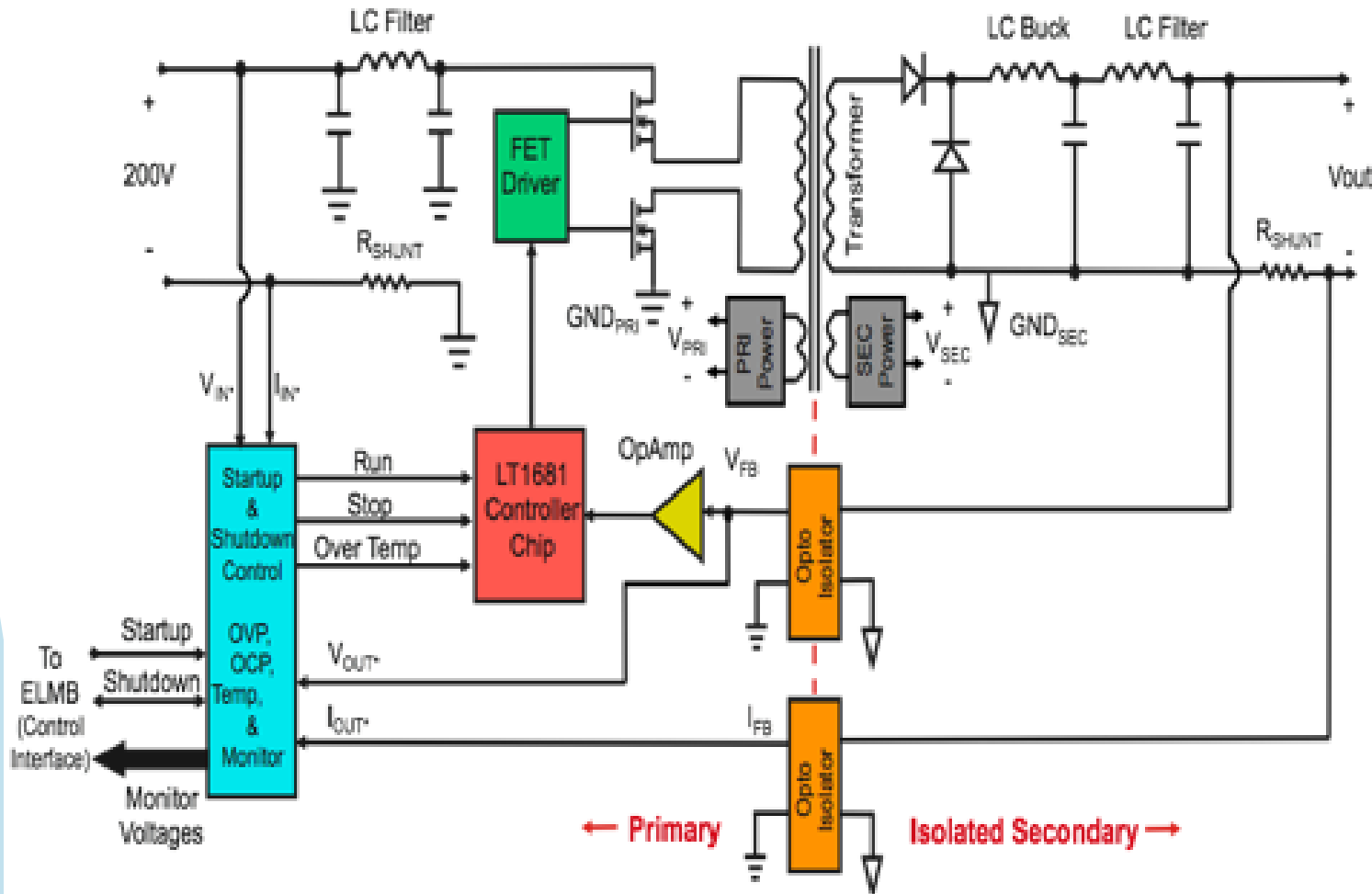

- LT1681 Controller Chip: Heart of design
- FET Drivers: Drive the Field Effect Transistors.
- FET's: When conducting current flows to the primary windings of the transformer which transfers energy to the secondary windings.
- Opto-Isolators: Provide voltage feedback for controlling the output voltage.
- Shunt Resistor: For measuring the output current
- Protection circuitry: Over Current Protection , Over Voltage Protection,

Version 8.1.0 Brick

Brick ID: 09PC021G-A

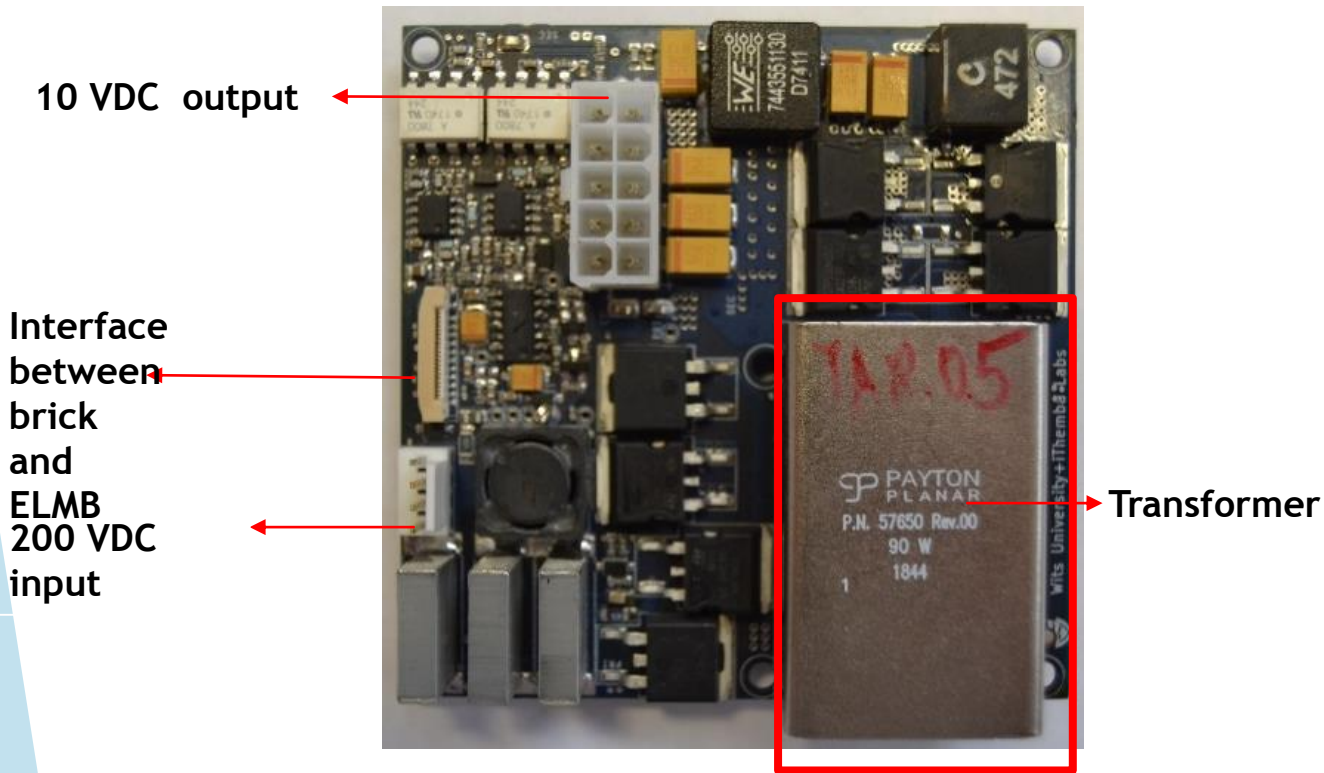

Version 8.1.0 Brick produced within South Africa

- Basic Topology: Transformer coupled buck converter.
- Function: +200 VDC bulk power converted to +10VDC at 2.5A which is distributed to Point-of-Load Regulators within the Front-End electronics.
- 8 identical bricks per LVPS.
- Identical footprint to bricks currently installed within ATLAS allowing for drop-in replacement.

LVPS brick Production Testing

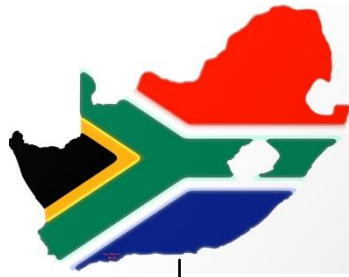

Production

- Pre-production expected to commence in 2020 in Capetown, South Africa.
- Approximately 1024 bricks to be produced.

Initial Testing

- Purpose: To ensure reliability and quality of new TileCAL LVPS bricks after production.
- Quickly quantifies a multitude of performance metrics of a LVPS brick.
- Station verifies all protection circuitry inbuilt into LVPS.
- Tests a single brick at a time.

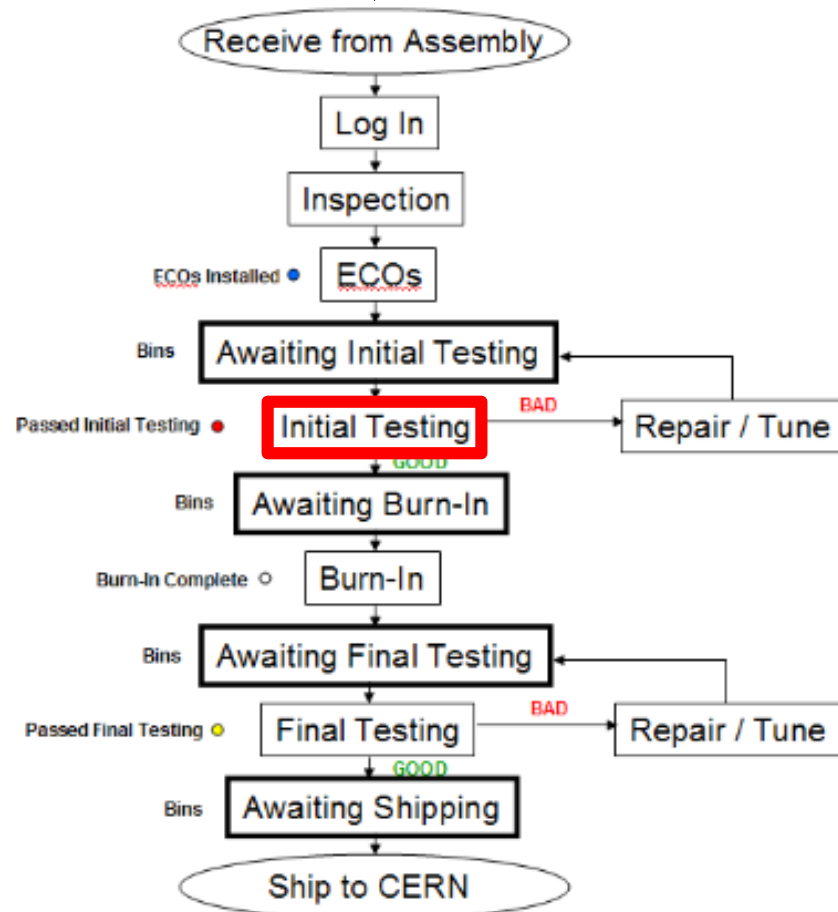

Initial Test Station

Wavesurfer Oscilloscope

Electronic load

Low voltage power supply

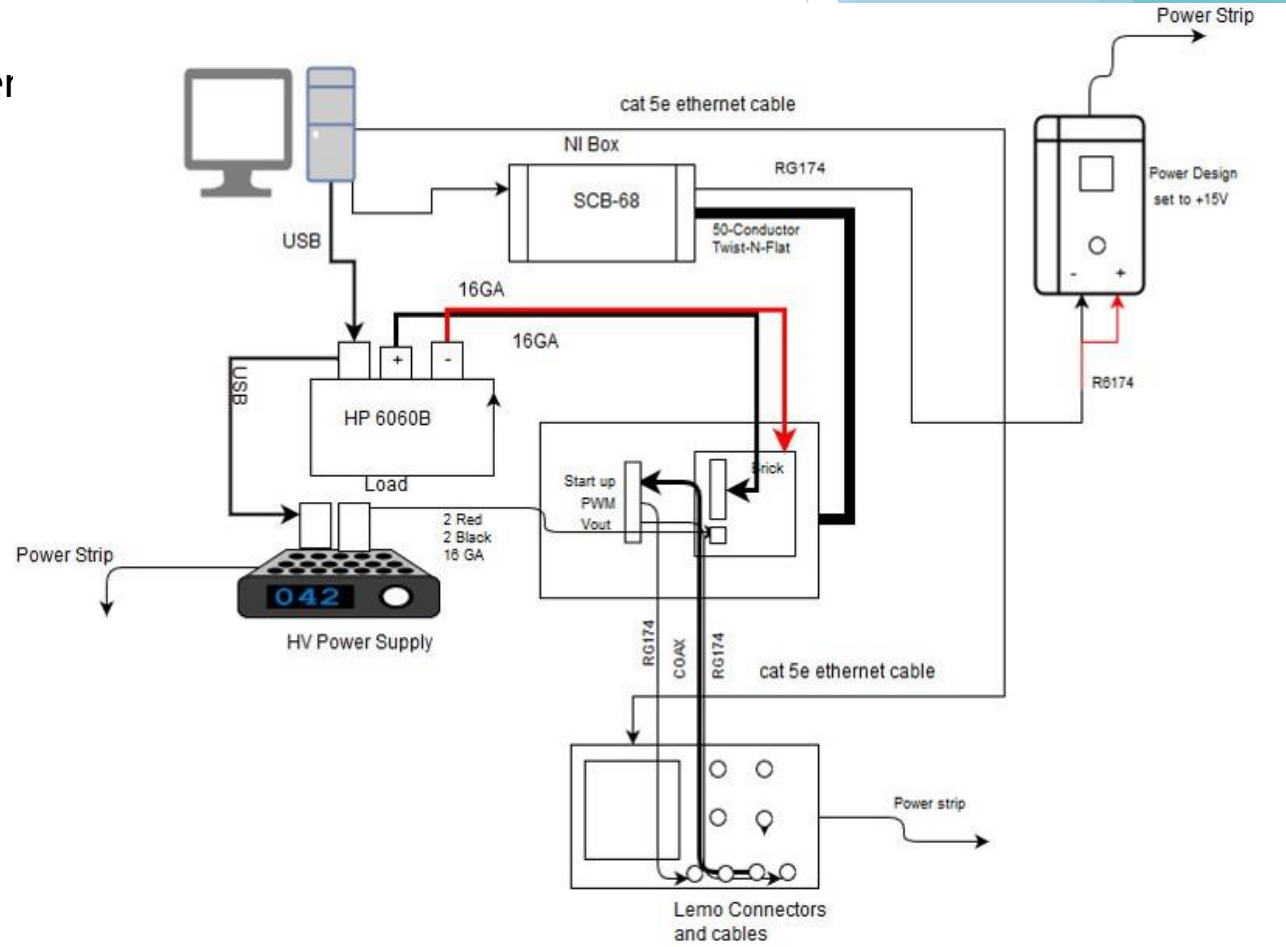
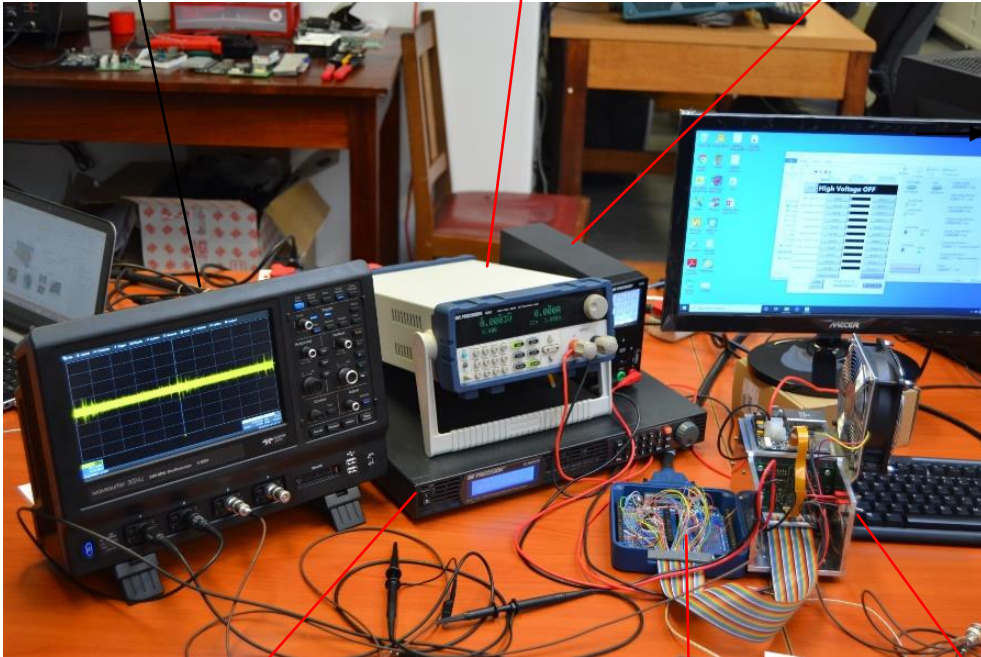

High voltage (DC) power supply

NI data acquisition card

Test rig with brick mounted

Wits Initial Test Stand

Test Station Schematic

Tests

UTA LVPS RUN WAVESURFER 3024.vi

User: Ryan Brick Type: A Serial Number:

STOP High Voltage OFF

Min. Stable Current Test #1 Details >>

Min. Output Voltage Test #2 Details >>

Voltage Trip Point Test #3 Details >>

Current Trip Point Test #4 Details >>

Output Analysis Test #5 Details >>

Startup Verification Test #6 Details >>

VOut / VMon vs Trim Test #7 Details >>

VOut / IMon vs Load Test #8 Details >>

Voltage Input Monitor Test #9 Details >>

Current Input Monitor Test #10 Details >>

Temperature Monitor Test #11 Details >>

Manual Control Manual Display

Clear Run All

OPERATION MODE: Manual Control ELOG

Run-Enable (15V signal) Start (15V power)

Output Voltage 10.7425 Volts

Input Voltage Monitor 1.04177 Volts

Input Current Monitor -0.0083523 Volts

Output Voltage Monitor 2.28994 Volts

Output Current Monitor 0.258126 Volts

Temperature Monitor 1 121.71 Degrees Fahrenheit

Temperature Monitor 2 87.4989 Degrees Fahrenheit

Runout 3.87137 Volts

EXIT MANUAL CONTROL

Temperature monitor

- A pre-synthesized programme used to perform a test sequence.
- Required adaptation to Wits hardware.
- Outputs relevant data as a txt fil, and/or a graphic with an associated outcome status
- The programme allows manual control of the LVPS brick.
- Allows for significant automation of testing.

Test parameters

Parameter	Minimum	Maximum
Frequency Standard Deviation	0	1000
Duty Cycle Standard Deviation	0	0.1
Frequency Max (Hz)	290000	350000
Frequency Min (Hz)	250000	310000
Minimum Stable Load (A)	2	2.1
Minimum Output Voltage (V)	9.8	10.2
Over Voltage Protection (V)	11.5	12
Over current Protection (A)	10.25	10.75
Output Root Mean Square Voltage	0	0.5
Clock duty cycle average	0	40
Clock Duty Cycle Standard Deviation	0	0.15
Start-up delay (Max) (s)	0.08	0.2

- Provide extrema of allowed operational environment of LVPS brick., i.e deviation about nominal.
- Based on operational limits of LVPS brick components.
- Over Voltage Protection (OVP), Over Current Protection (OCP) are very important.



Test 3 - Test sequence

- Test 3 determines whether the protection circuitry of the LVPS brick is functioning correctly. In this test the Over-Voltage-Protection (OVP) circuitry is assessed.
- While operating at minimum stable load, the output voltage is increased by decreasing the Trim voltage, until the built-in OVP shuts down the brick.
- A pass verdict is rendered if the the OVP circuitry activated within the range of 11.5 V and 12.0 V.
- On completion of test 3 the software exports the data as a text file that can then be stored and later analysed 4.10

The following test was completed in the WITS HEP electronics laboratory.

Data of Test 3: Over Voltage Trip Point

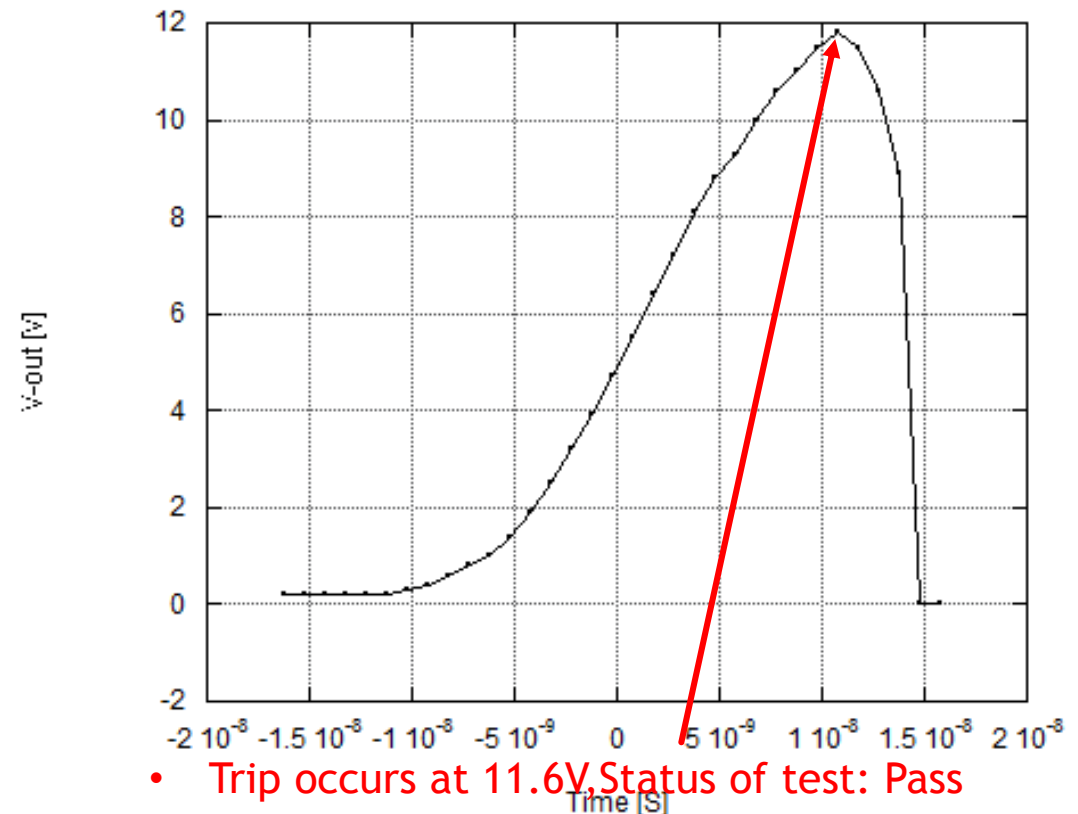

Test 4 - Test sequence

- Similarly to test 3 this test serves to verify that the Over-Current-Protection (OCP) circuitry of the LVPS brick is functioning as designed.
- This is done by increasing the load until the OCP circuitry trips the brick.
- The trip should occur between 10.25 A and 10.75 A for the brick to pass.
- On completion of test 4 the software exports the data as a text file which can be stored and later analysed.

The following test was completed in the WITS HEP electronics laboratory.

Data of Test 4: Over Current Trip Point

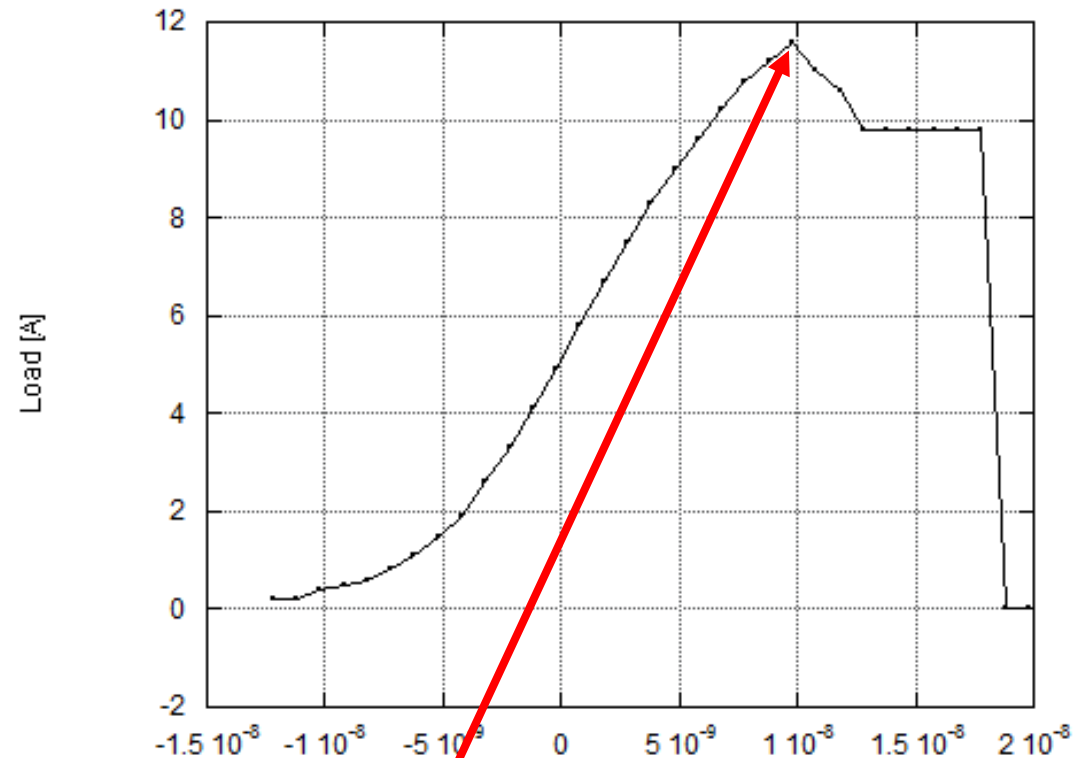

Trip occurs at 11.6A

Status of Test : Failure

Reason: Exceeded Maximum allowed value of 10.7A

The following test was completed in the WITS HEP electronics laboratory

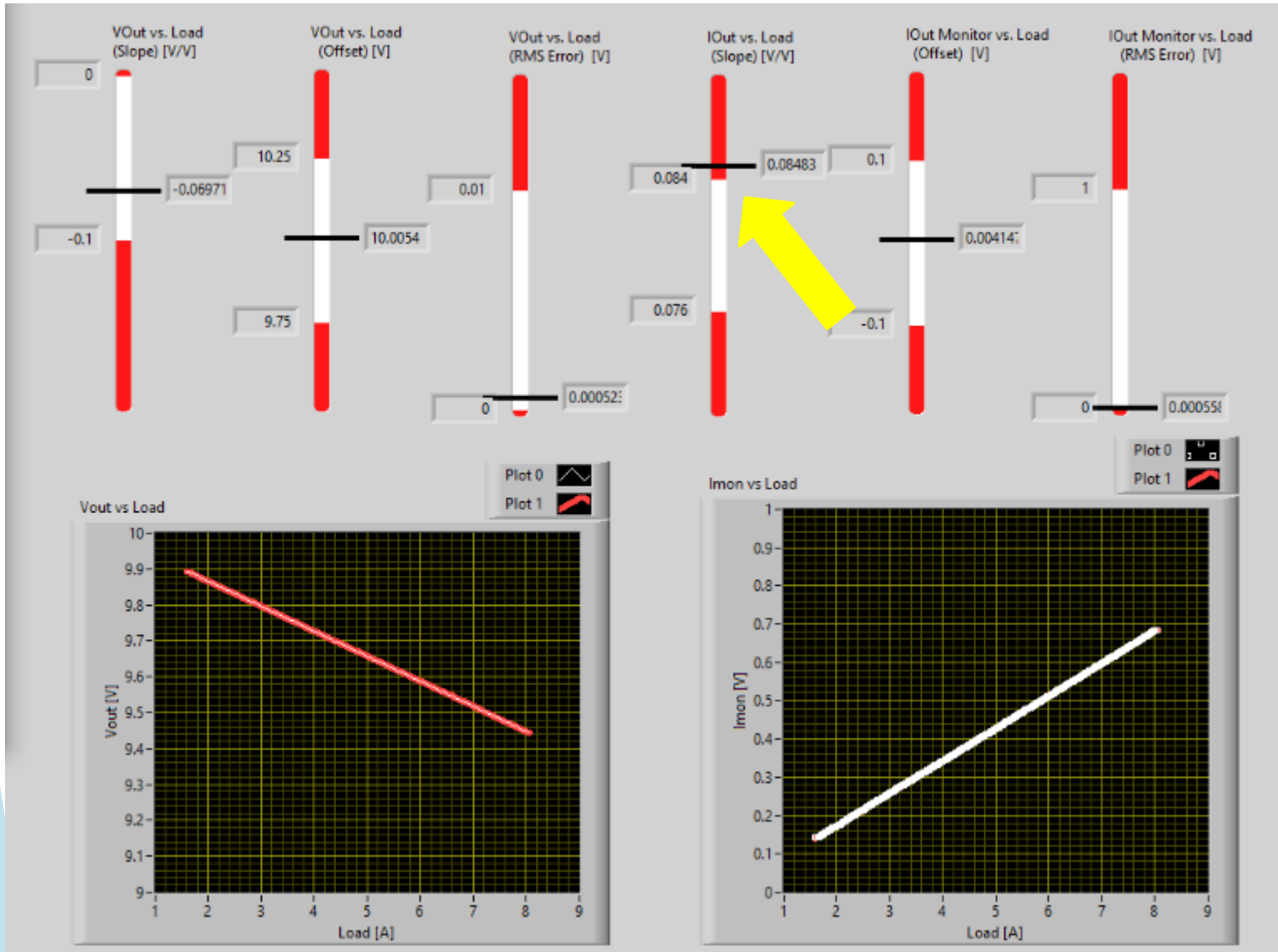

Test 5: Output analysis

Brick ID:09PC021G

Test 5 - Test sequence

- Test 5 serves as an analysis of the outputs of a LVPS brick.
- The brick is operated at nominal load (2.5 A).
- The trim voltage is adjusted to set the output voltage at nominal value - (+10 VDC).

Test 5 - Test results

- All but one of the sub-tests yielded a desirable result.
- This graphic is outputted along with the final test verdict.

Summary

Test	Description	Status
Test 1	Min stable load	Pass
Test 2	Min output voltage	Pass
Test 3	Over voltage protection	Pass
Test 4	Over current protection	Out of nominal range
Test 5	Output analysis	Out of nominal range
Test 6	Start-up delay	Out of nominal range
Test 7	Output/monitor voltage vs trim voltage	Pass
Test 8	Current monitor vs load	Out of nominal range
Test 9	Input voltage monitor	Pass
Test 10	Input current monitor	Pass
Test 11	Temperature monitor	Pass

- 16 version 8.1.0 LVPS bricks were manufactured.
- The initial test station was constructed.
- An entire initial test sequence was successfully completed verifying the functionality of the apparatus in preparation pre-production.
- The LVPS brick ID: 09PC021G- found to yield tests results that lied out of the allowed variance from nominal.
- In this case the brick would have to undergo repair/tuning before shipment