



UNIVERSITY OF  
BIRMINGHAM



ALICE

# Open charm and charm-tagged jets production with ALICE at LHC

Jakub Kvapil for the ALICE collaboration

University of Birmingham, UK

20th Conference of Czech and Slovak Physicists  
Prague

# The Equation of High Energetic Collision...

- Heavy flavour production in pp is well described by the factorisation theorem:

**Production cross section**  
of hadron H from the collision of hadrons A and B

**Parton Distribution Function (PDF)**  
Probability of finding parton m inside hadron M with fraction momentum  $x_m = p_m/p_M$

**Hard scattering**  
Cross section of the process  $a + b \rightarrow c + d$

**Fragmentation function**  
Probability of producing hadron H from the outgoing parton pair

$$\sigma_{A+B \rightarrow H+X} = \sum_{abcd} \iint dx_a dx_b \cdot f_{a/A}(x_a) f_{b/B}(x_b) \cdot \sigma_{a+b \rightarrow c+d}(x_a, x_b, p_c, p_d) * D(p_c, p_d, p_H)$$

Non-perturbative

Perturbative QCD

Non-perturbative

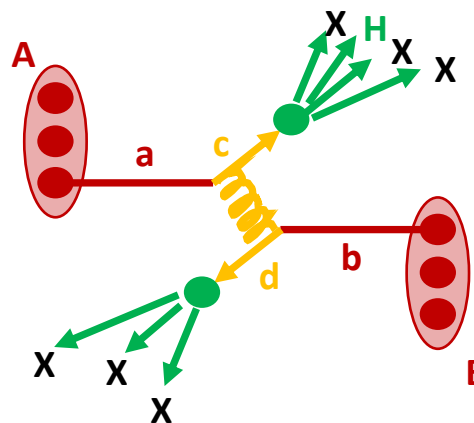
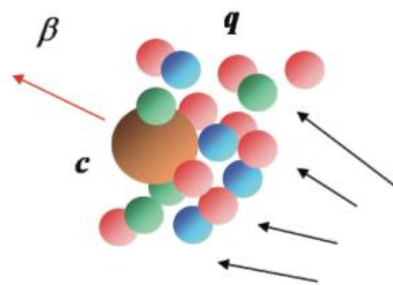

- Fragmentation:** Leading partons can split into other partons (parton shower)
- Hadronization:** Parton showers form hadrons
  - Lund string model – leading order
  - Colour reconnection – beyond leading colour
- Decay:** Hadron decay to final particles

# The Equation of High Energetic Collision...

- Heavy flavour production in pp is well described by the factorisation theorem:

**Production cross section**  
of hadron H from the collision of hadrons A and B

**Parton Distribution Function (PDF)**  
Probability of finding parton m inside hadron M with fraction momentum  $x_m = p_m/p_M$

**Hard scattering**  
Cross section of the process  $a + b \rightarrow c + d$

**Fragmentation function**  
Probability of producing hadron H from the outgoing parton pair

$$\sigma_{A+B \rightarrow H+X} = \sum_{abcd} \iint dx_a dx_b \cdot f_{a/A}(x_a) f_{b/B}(x_b) \cdot \sigma_{a+b \rightarrow c+d}(x_a, x_b, p_c, p_d) * D(p_c, p_d, p_H)$$

Non-perturbative

Perturbative QCD

Non-perturbative

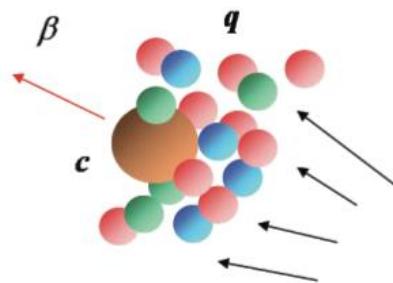

This is more reality

Underlying event

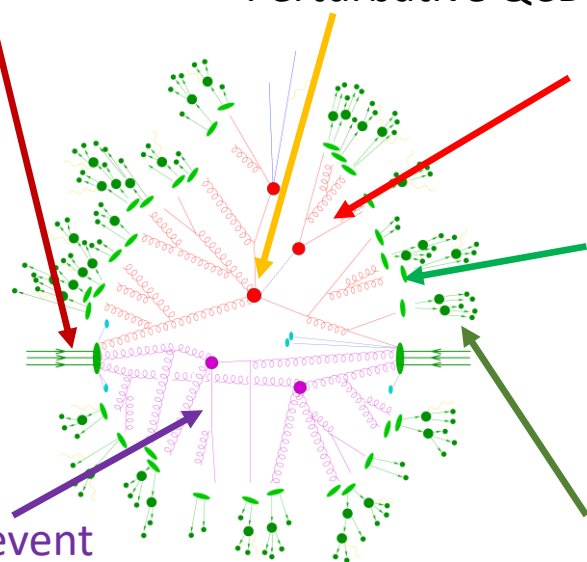

- Fragmentation:** Leading partons can split into other partons (parton shower)
- Hadronization:** Parton showers form hadrons
  - Lund string model – leading order
  - Colour reconnection – beyond leading colour
- Decay:** Hadron decay to final particles

(T. Gleisberg et al., JHEP02 (2004) 056)

# ...and with Quark-Gluon Plasma

- Heavy flavour production in pp is well described by the factorisation theorem:

**Production cross section**  
of hadron H from the  
collision of hadrons A and B

**Parton Distribution Function (PDF)**  
Probability of finding parton m  
inside hadron M with fraction  
momentum  $x_m = p_m/p_M$

**Hard scattering**  
Cross section of the  
process  $a + b \rightarrow c + d$

**Fragmentation function**  
Probability of producing hadron H  
from the outgoing parton pair  
**modified with the medium influence**

$$\sigma_{A+B \rightarrow H+X} = \sum_{abcd} \iint dx_a dx_b \cdot f_{a/A}(x_a) f_{b/B}(x_b) \cdot \sigma_{a+b \rightarrow c+d}(x_a, x_b, p_c, p_d) * D(p_c, p_d, p_H) * \text{Medium}$$

Non-perturbative

Perturbative QCD

Non-perturbative

**This is more reality**

**Ratios of baryon-to-meson spectra  
in different collision systems is  
sensitive to hadronization  
mechanism at low  $p_T$**

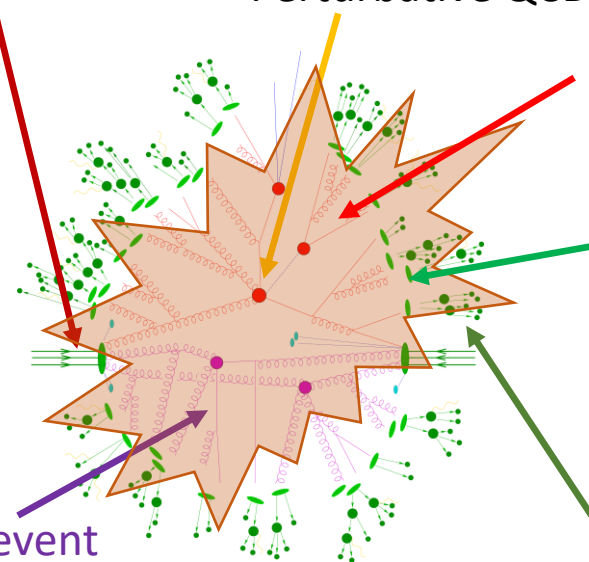

- Fragmentation:** Leading partons can split into other partons (parton shower)
- Hadronization:** Parton showers form hadrons
  - Lund string model – leading order
  - Colour reconnection – beyond leading colour
- Decay:** Hadron decay to final particles

(T. Gleisberg et al., JHEP02 (2004) 056)

# Physics Motivation

- During the initial phase of the collision quarks and gluons can scatter back to back creating collimated sprays of particles - **jets**
- Heavy Flavour (HF) mesons (charm and beauty)
  - Heavy quarks ( $c, b$ ) are mostly produced in **hard scatterings** at the initial stage of the collision
  - Production cross section can be **calculated** within pQCD due to large quark masses for **every momentum**  $p_{T,D}$
  - **(HF) jets** allow smaller dependence on hadronization process due to including all particles from parton shower

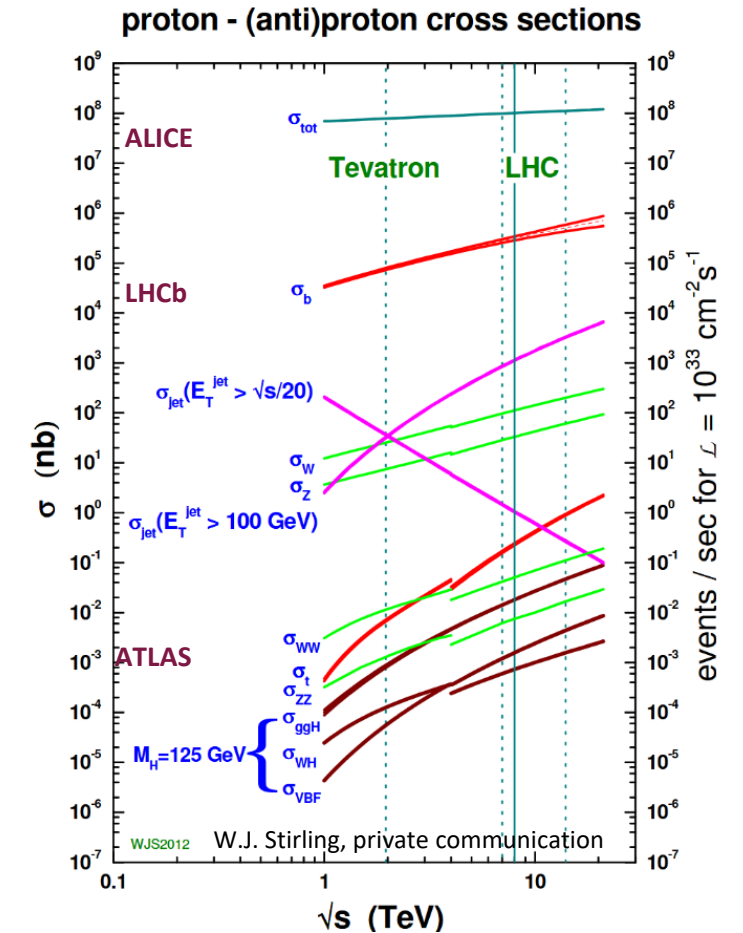
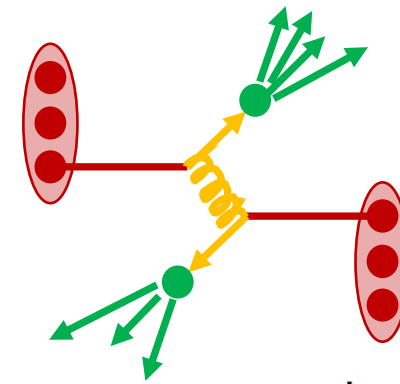

# Physics Motivation

- During the initial phase of the collision quarks and gluons can scatter back to back creating collimated sprays of particles - **jets**
- Heavy Flavour (HF) mesons (charm and beauty)
  - Heavy quarks ( $c, b$ ) are mostly produced in **hard scatterings** at the initial stage of the collision
  - Production cross section can be **calculated** within pQCD due to large quark masses for **every momentum**  $p_{T,D}$
  - **(HF) jets** allow smaller dependence on hadronization process due to including all particles from parton shower
- Proton-proton collisions
  - Considered as “vacuum” case and is important test for pQCD calculations
    - Modified **fragmentation** – parton shower
    - Effects of **recombination** and **colour reconnection** on hadronization
    - **Flavour and mass dependence**
    - **Quark** (HF jets) **vs gluon** (other jets) jet difference

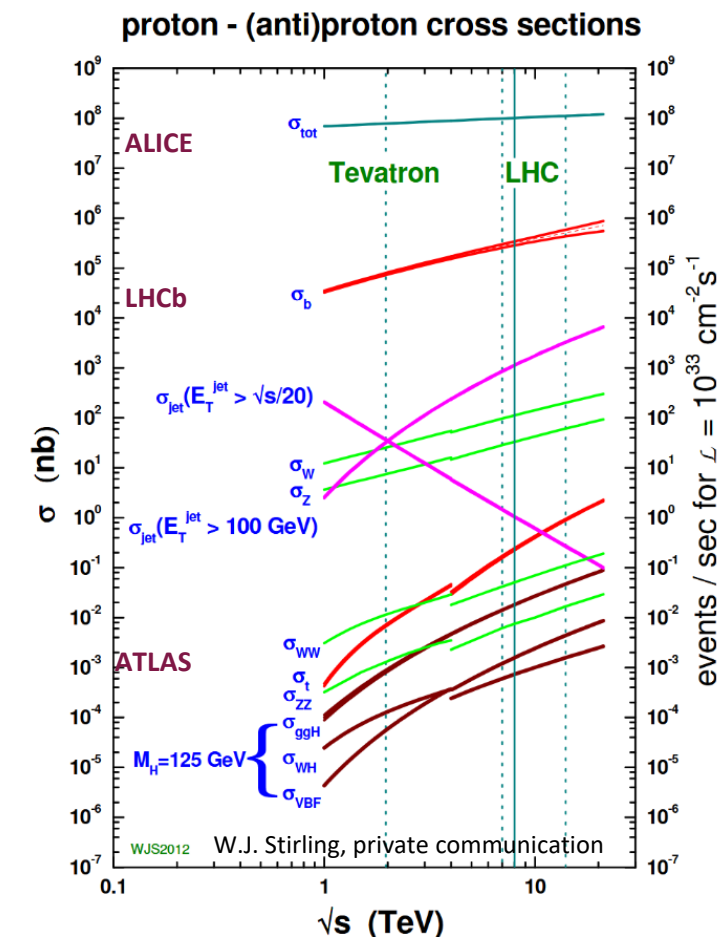
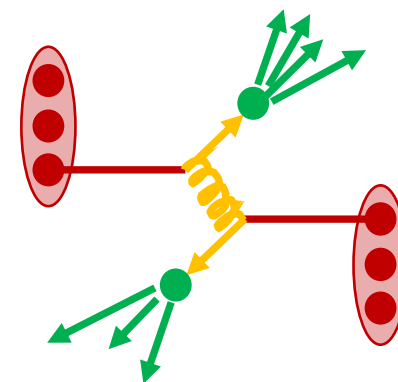

# Physics Motivation

- During the initial phase of the collision quarks and gluons can scatter back to back creating collimated sprays of particles - **jets**
- Heavy Flavour (HF) mesons (charm and beauty)
  - Heavy quarks ( $c, b$ ) are mostly produced in **hard scatterings** at the initial stage of the collision
  - Production cross section can be **calculated** within pQCD due to large quark masses for **every momentum**  $p_{T,D}$
  - **(HF) jets** allow smaller dependence on hadronization process due to including all particles from parton shower
- Proton-proton collisions
  - Considered as “vacuum” case and is important test for pQCD calculations
    - Modified **fragmentation** – parton shower
    - Effects of **recombination** and **colour reconnection** on hadronization
    - Flavour and mass dependence
    - Quark (HF jets) vs gluon (other jets) jet difference
- Ion-ion collisions
  - **Quark-gluon plasma is created**, a hot dense medium where quarks and gluons are bound only weakly - free to move on their own
  - **HF mesons** can be used as **ideal “hard” probe** of this medium

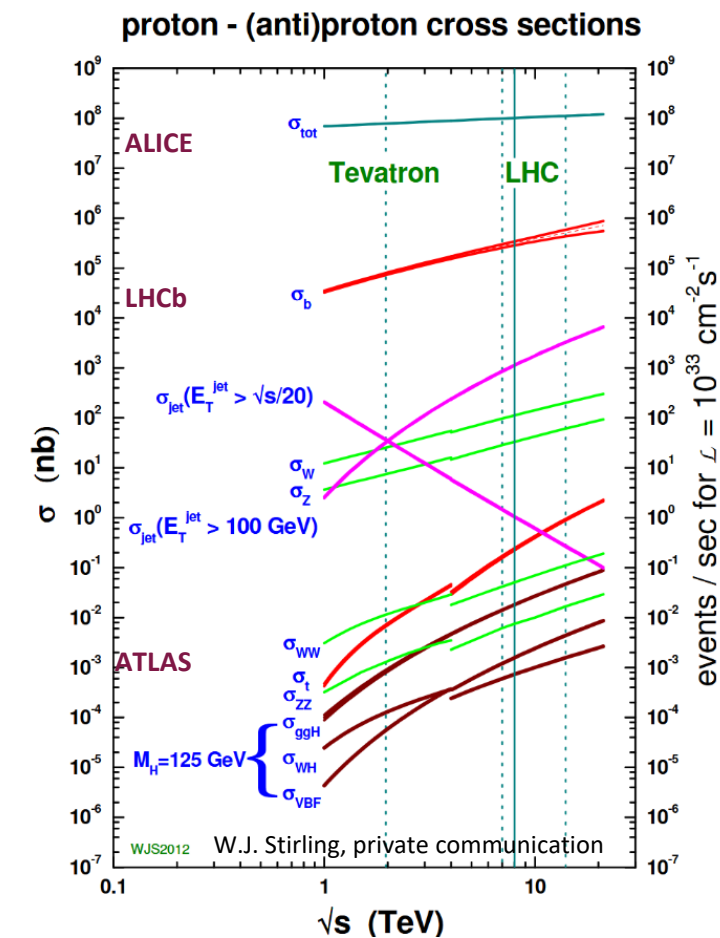
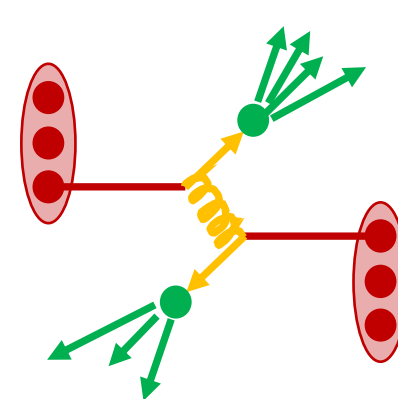

# The ALICE Detector – Inner Tracking System

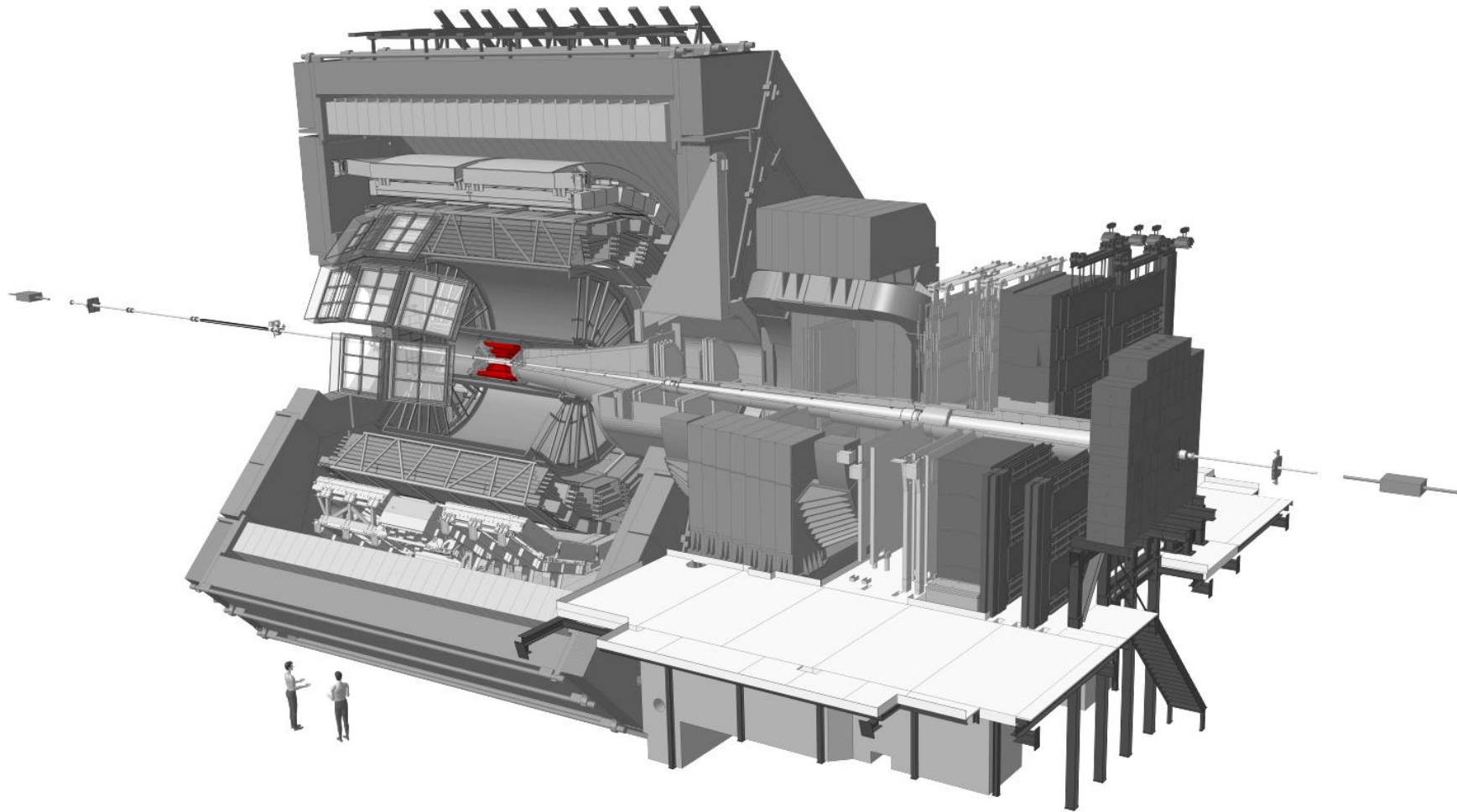

- Detectors

- ITS  $|\eta| < 0.9$

- Vertexing and tracking

# The ALICE Detector – Time Projection Chamber

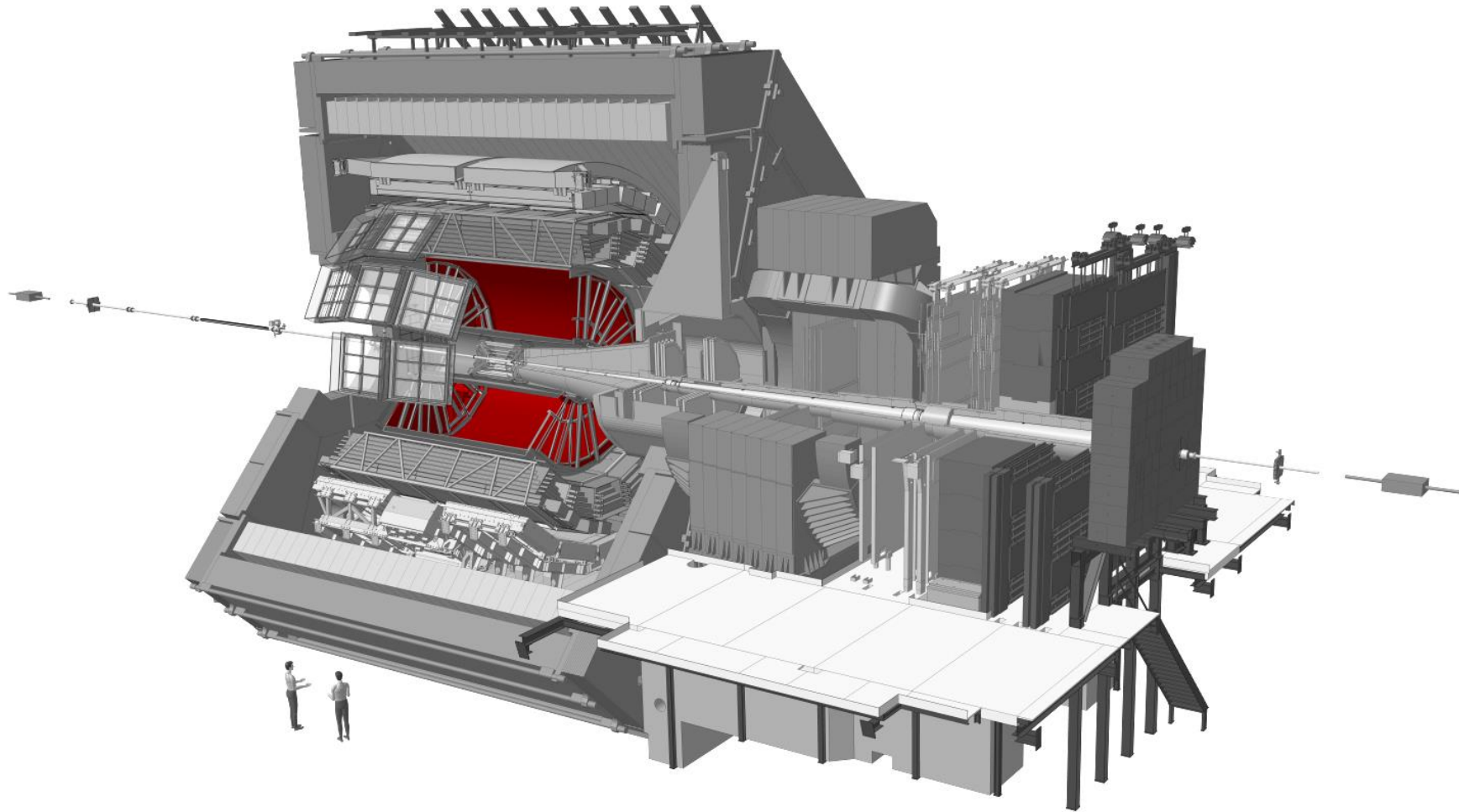

## • Detectors

- ITS  $|\eta| < 0.9$ 
  - Vertexing and tracking
- TPC  $|\eta| < 0.9$ 
  - Tracking and PID

# The ALICE Detector – Time of Flight

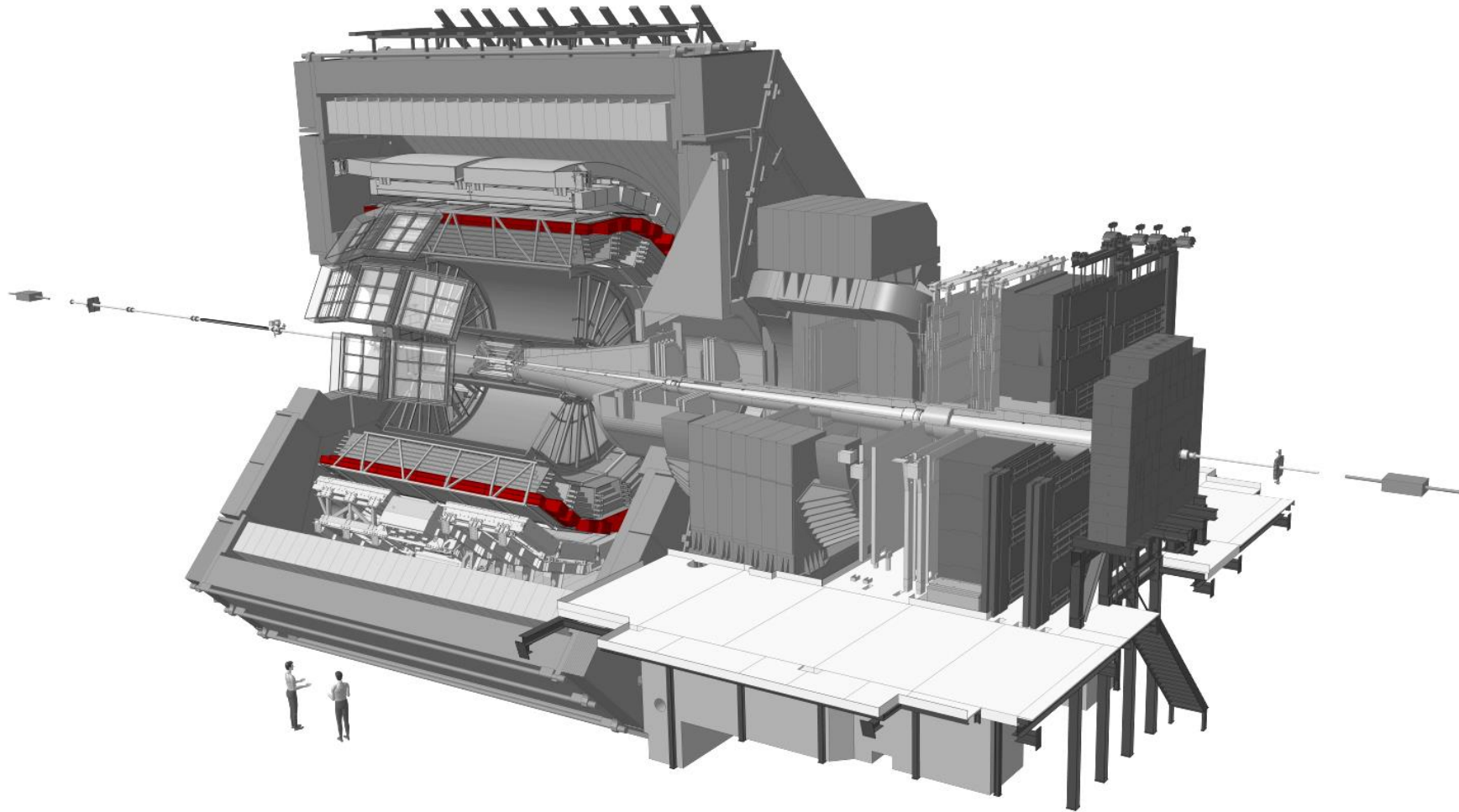

## • Detectors

- **ITS**  $|\eta| < 0.9$ 
  - Vertexing and tracking
- **TPC**  $|\eta| < 0.9$ 
  - Tracking and PID
- **TOF**  $|\eta| < 0.9$ 
  - PID

# The ALICE Detector – Calorimeters

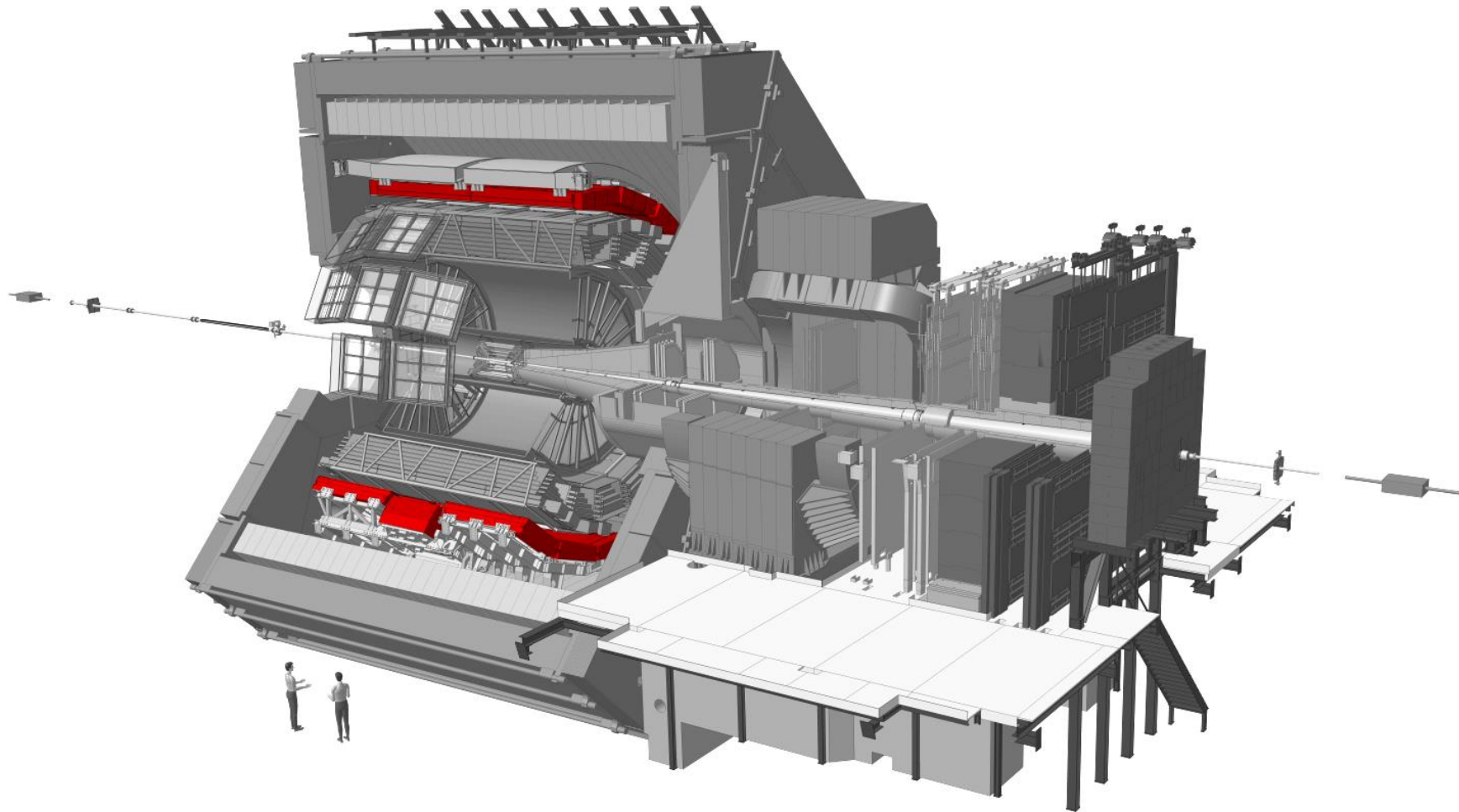

## • Detectors

- **ITS**  $|\eta| < 0.9$ 
  - Vertexing and tracking
- **TPC**  $|\eta| < 0.9$ 
  - Tracking and PID
- **TOF**  $|\eta| < 0.9$ 
  - PID
- **EMCAL/PHOS**  $|\eta| < 0.7$ 
  - ePID and trigger

# The ALICE Detector – V0

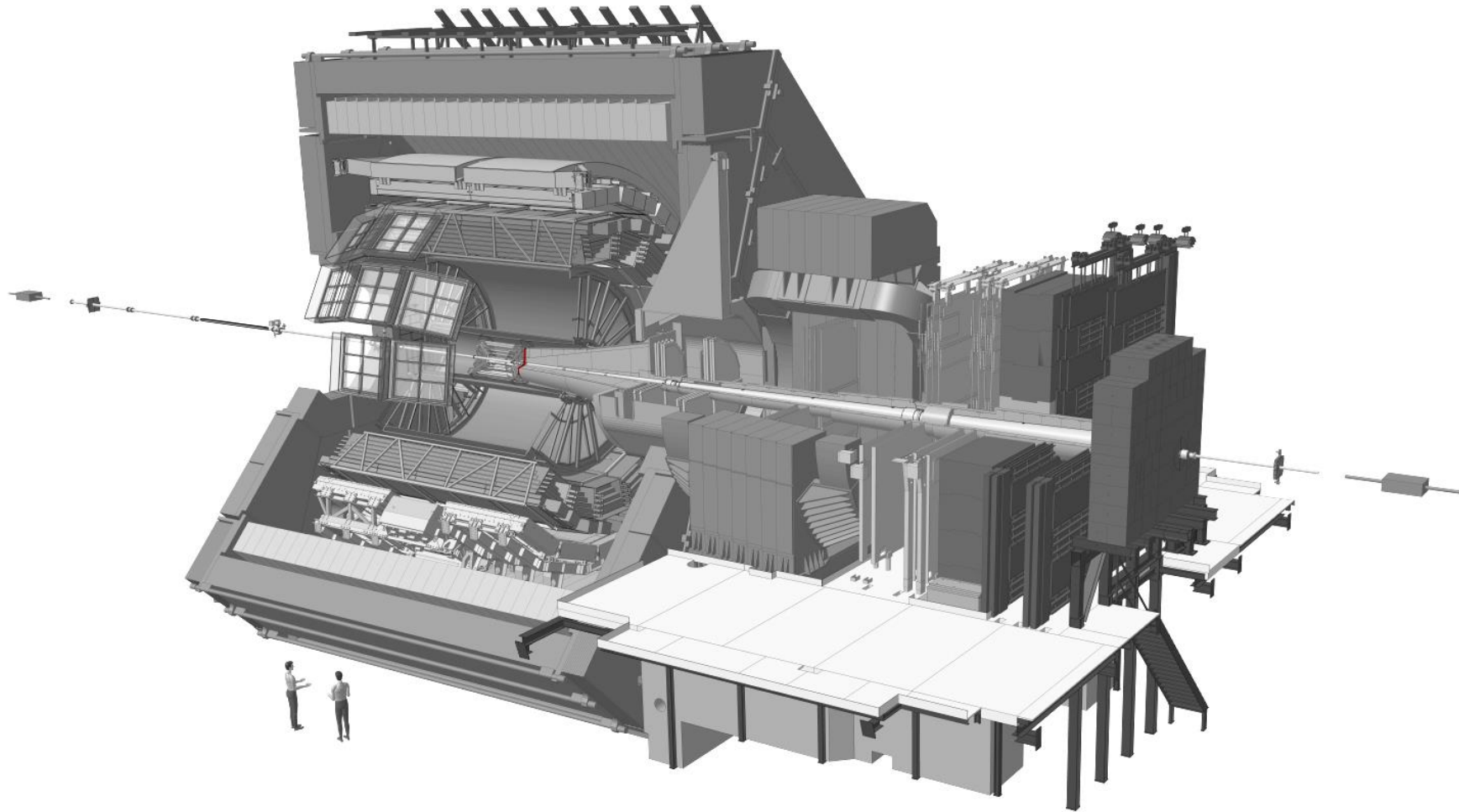

## • Detectors

- **ITS**  $|\eta| < 0.9$ 
  - Vertexing and tracking
- **TPC**  $|\eta| < 0.9$ 
  - Tracking and PID
- **TOF**  $|\eta| < 0.9$ 
  - PID
- **EMCAL/PHOS**  $|\eta| < 0.7$ 
  - ePID and trigger
- **V0**  $-3.7 < \eta - 1.7$   
 $2.8 < \eta - 5.1$ 
  - Trigger and background rejection

# Let's study the hadronization part

- Effect of **coalescence/recombination** on hadronization
  - Charm quark will pick up other quark and create a particle
- Meson/meson ratio ( $D^+ / D^0$ )
  - Flat with  $p_T$  and compatible with theory

- Strange meson/non-strange meson ( $D_s / D$ )
  - Does not depend on multiplicity and compatible with  $e^+ e^-$

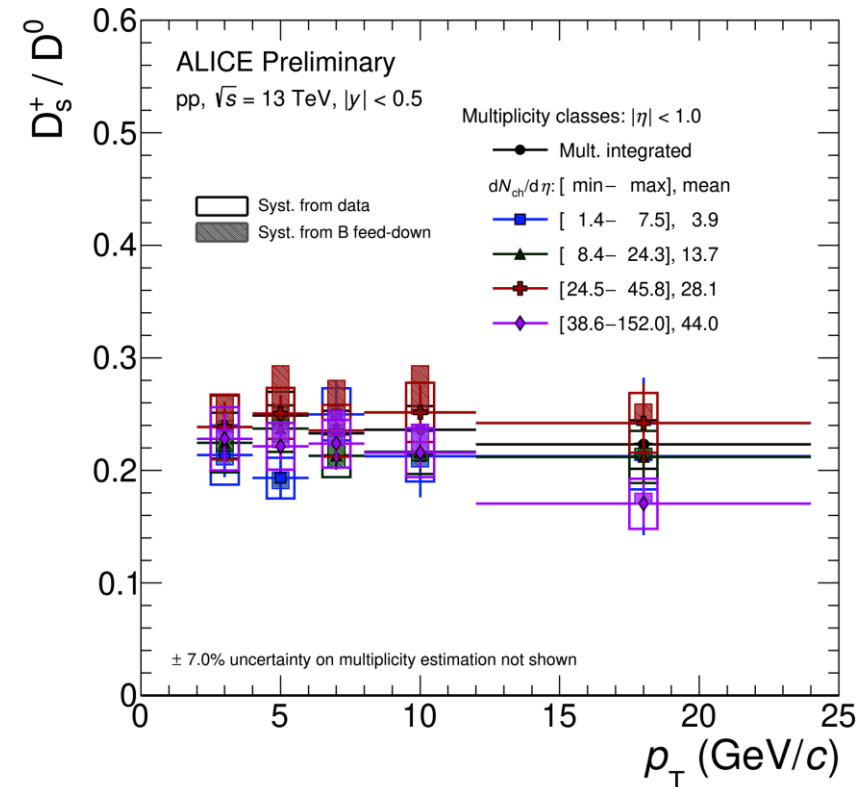
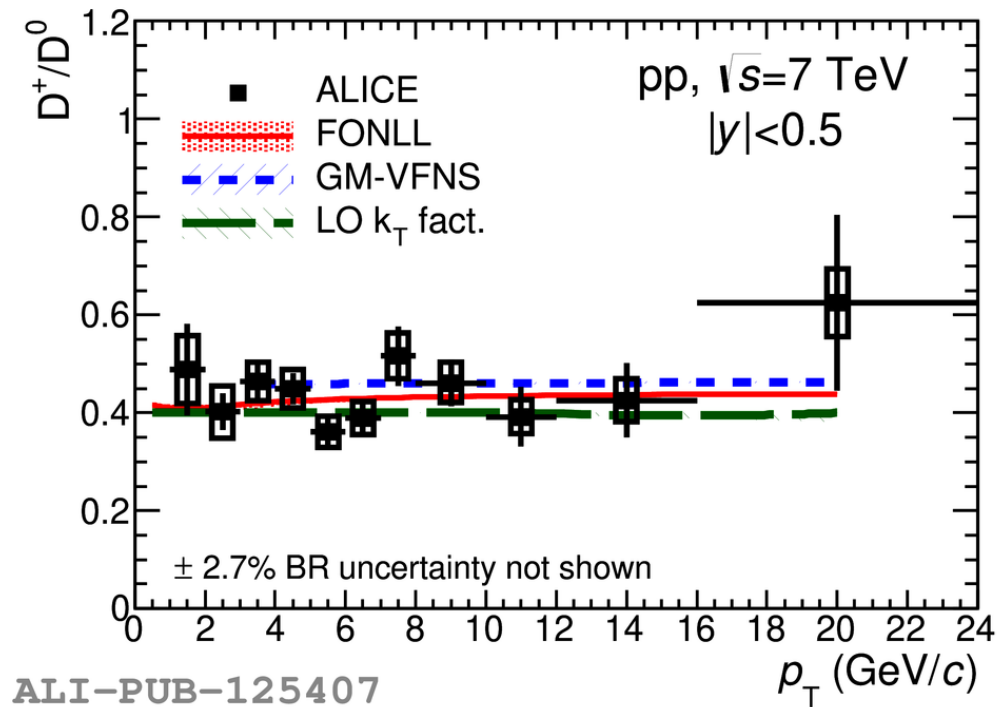

# Let's study the hadronization part

- Effect of **coalescence/recombination** on hadronization
  - Charm quark will pick up other quark and create a particle
- Meson/meson ratio ( $D^+/D^0$ )
  - Flat with  $p_T$  and compatible with theory
- Baryon/meson ( $\Lambda_c^+/D^0$ )
  - **Big enhancement from  $e^+e^-$  collisions with strong  $p_T$  dependence**
  - Significant enhancement with increasing multiplicity
    - QGP droplet?
  - Fragmentation not universal? Additional effects?
    - Colour reconnection, recombination, unobserved baryonic state?
  - Largely underestimated with default PYTHIA8 (Monash)
  - Better described by PYTHIA8 with colour reconnection (string formation beyond leading colour)
  - Colour reconnection effect seems to increase with multiplicity

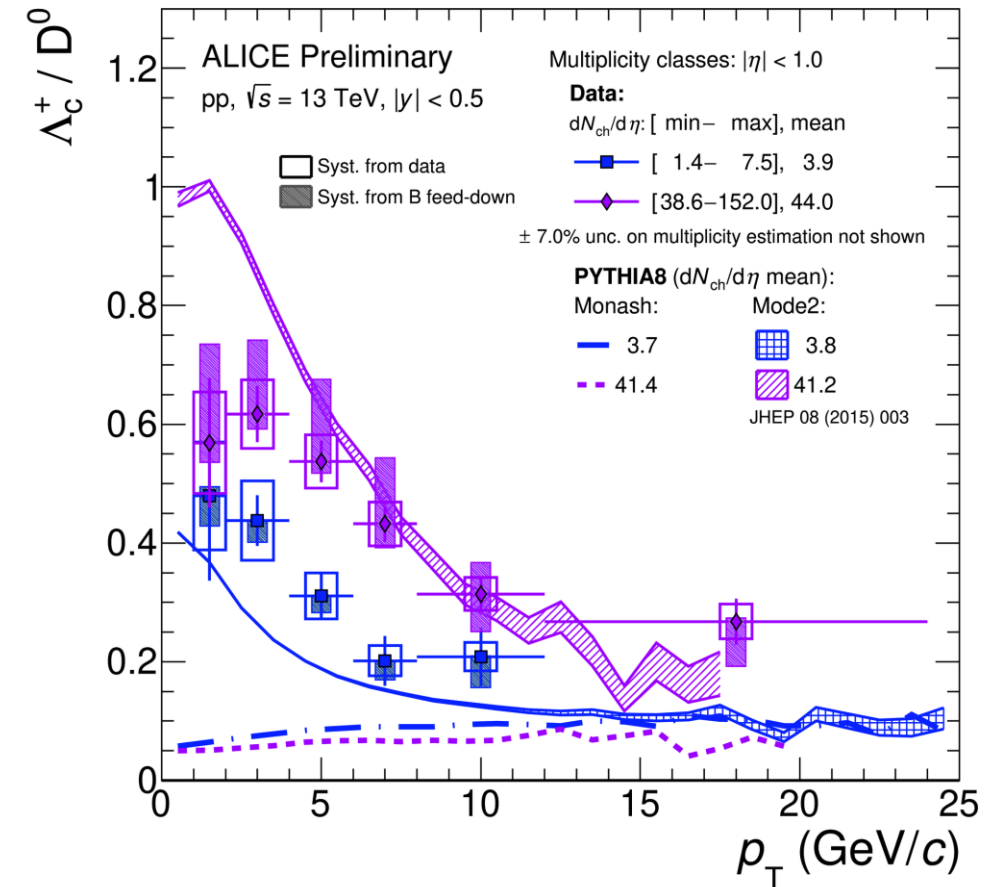
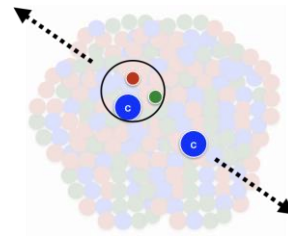

ALI-PREL-336442

PYTHIA8: (Comput. Phys. Commun. 178 (2008) 852)  
 PYTHIA8 Monash (Eur. Phys. J. C 74 (2014) 3024)  
 PYTHIA8 CR Mode2 (JHEP 08 (2015) 003)

# Let's study the hadronization part

- Effect of **coalescence/recombination** on hadronization
  - Charm quark will pick up other quark and create a particle
- Meson/meson ratio ( $D^+ / D^0$ )
  - Flat with  $p_T$  and compatible with theory
- Baryon/meson ( $\Lambda_c^+ / D^0$ )
  - **Big enhancement from  $e^+e^-$  collisions with strong  $p_T$  dependence**
- **Similar  $p_T$  trend going from pp to p-Pb and Pb-Pb**
  - Hint of large  $\Lambda_c^+ / D^0$  in Pb-Pb
  - Different hadronization?
  - Radial flow push?

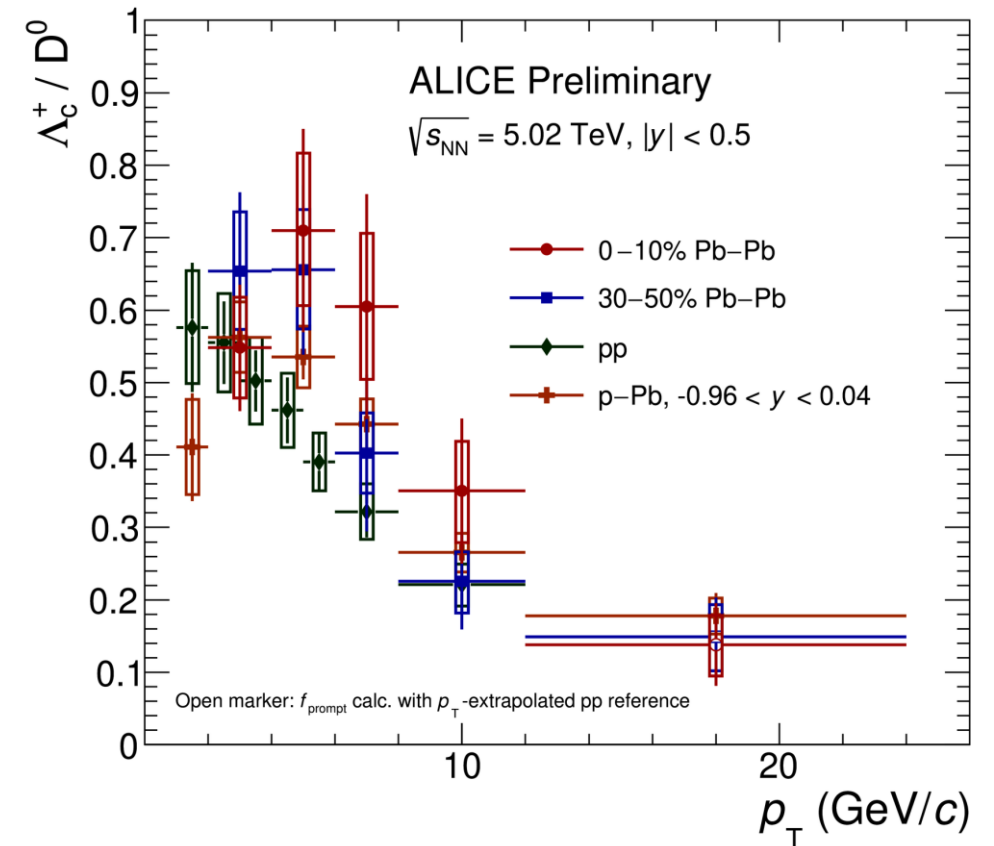
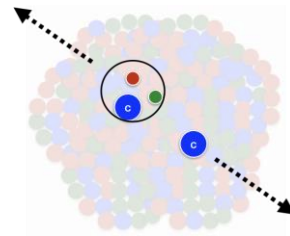

ALI-PREL-321706

PYTHIA8: (Comput. Phys. Commun. 178 (2008) 852)  
 PYTHIA8 Monash (Eur. Phys. J. C 74 (2014) 3024)  
 PYTHIA8 CR Mode2 (JHEP 08 (2015) 003)

# Massive baryon states

- $\Sigma_c^{0,+} / D^0$   $\Sigma_c^{0,+} = (ddc, udc, uuc)$ 
  - First measurement of  $\Sigma_c^{0,+}$  at LHC
  - Data underestimated by PYTHIA8 (Monash)
  - Well reproduced by colour reconnection beyond leading colour

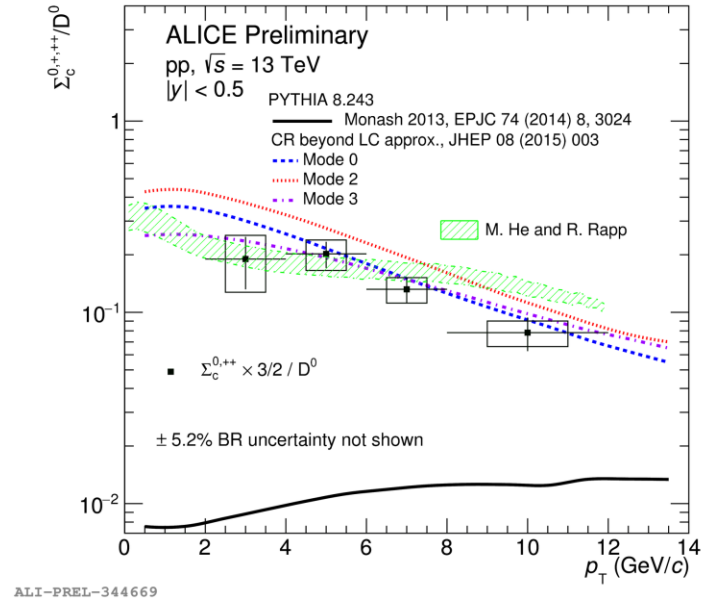

# Massive baryon states

- $\Sigma_c^{0,+,++} / D^0$   $\Sigma_c^{0,+,++} = (ddc, udc, uuc)$ 
  - First measurement of  $\Sigma_c^{0,+,++}$  at LHC
  - Data underestimated by PYTHIA8 (Monash)
  - Well reproduced by colour reconnection beyond leading colour
- $\Xi_c^{0,+} / D^0$   $\Xi_c^{0,+} = (usc, dsc)$ 
  - Not reproduced by any model
- $\Sigma_c$  and  $\Xi_c$  similar mass but different quark content
  - Role of diquark production?
  - Monash string treating of fragmentation suppress production of spin-1 diquarks from spin-3/2 and spin-1/2 baryon multiplets
  - CR junction system allows less suppression – same ud, dd and uu production

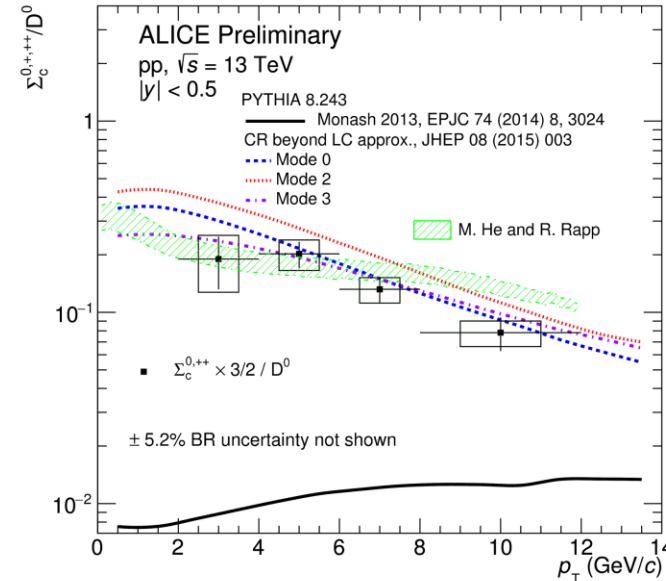

ALI-PREL-344669

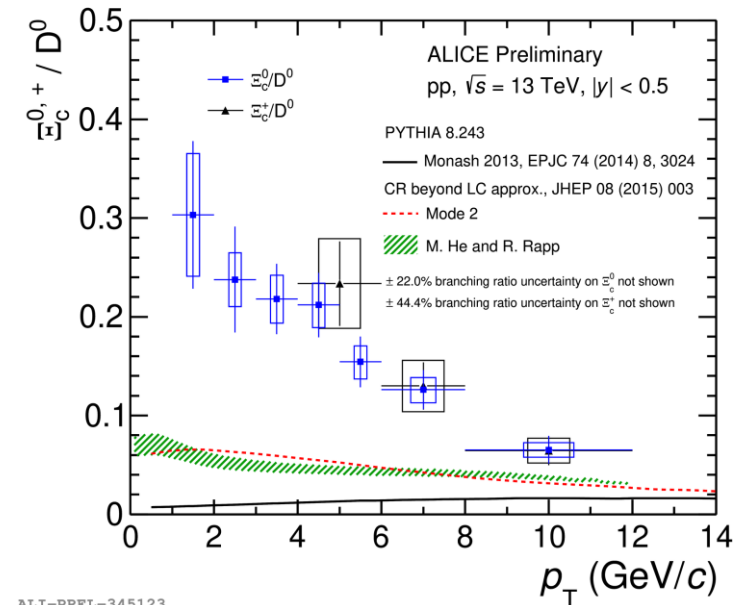

ALI-PREL-345123

# How the jets can help?

- Smaller dependence on the hadronization models allow better comparison to QCD
- **Gluon initiated jets** – broader fragmentation
- **Quark initiated jets** – more collimated
- **Inclusive jets**
  - Powerful probes of QCD
  - Well constrained at high  $p_T$ , low  $p_T$  experimentally challenging
  - **Mostly gluon initiated**
- **Heavy-flavour (HF) jets:**
  - $m_q > \Lambda_{\text{QCD}}$  - perturbative production down to low  $p_T$
  - HF conserved through the parton shower
  - **Quark initiated**
- Inclusive vs heavy-flavour jets at low  $p_T$ 
  - Effect of Casimir factors and dead cone

Gluon initiated

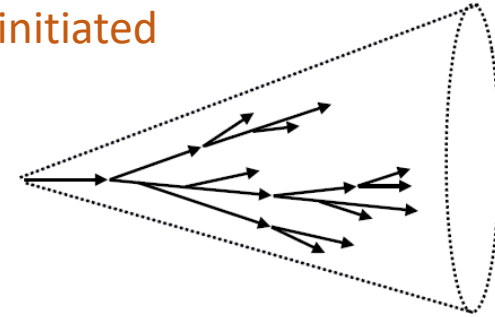

Quark initiated

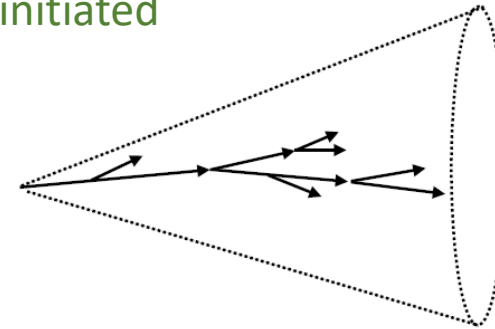

HF quark initiated

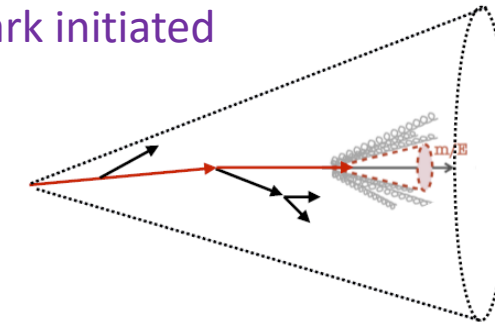

# $D^0/\Lambda_c^+$ -tagged jets: $z_{\parallel}^{ch}$ probability density



ALICE

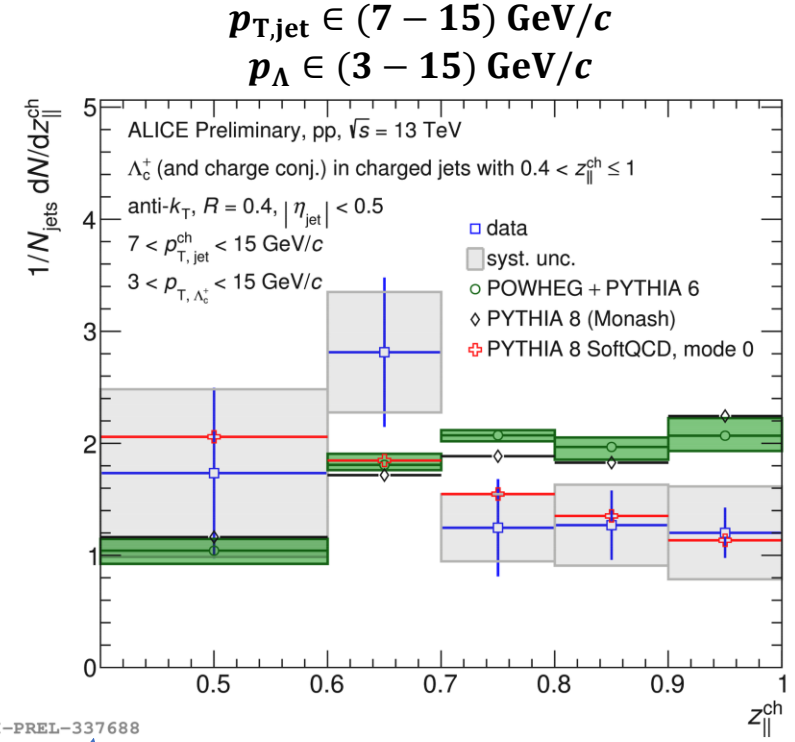
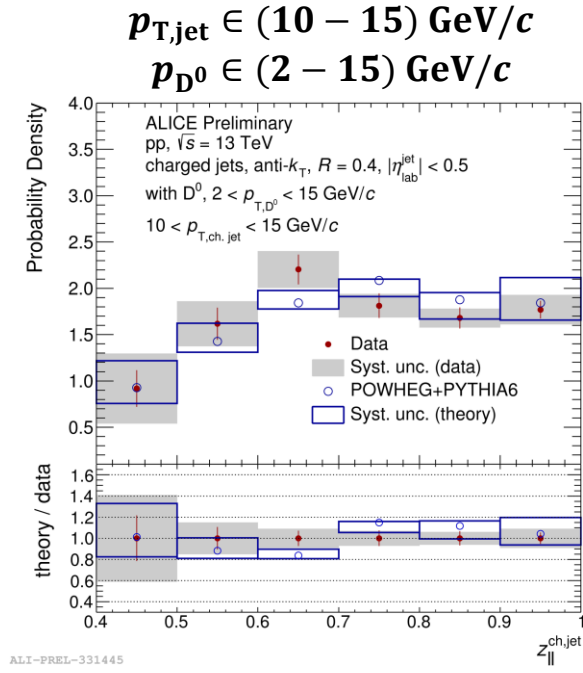
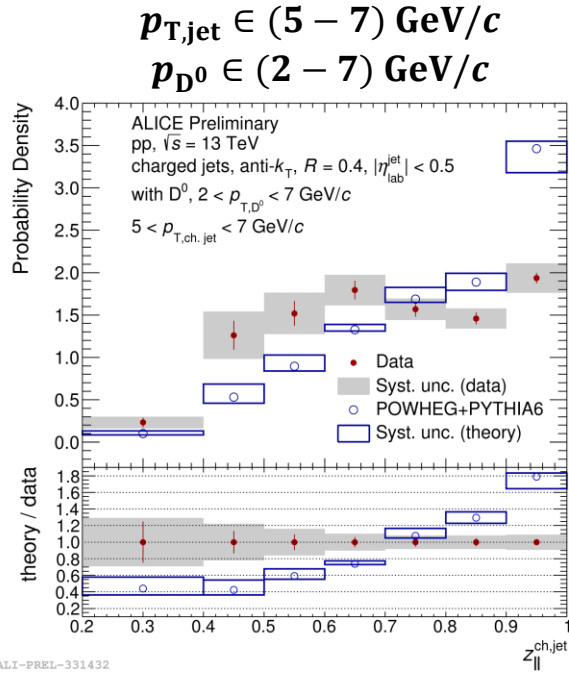

- **PYTHIA6 + POWHEG hvq + CT10NLO PDF**
  - Consistent within uncertainty for high  $p_{T,jet}$
  - Softer fragmentation in data for low  $p_{T,jet}$
- Next step  $\Lambda_c^+/D^0$  in jets

Less collimated

More collimated

$$z_{\parallel}^{ch} = \frac{\vec{p}_D \cdot \vec{p}_{ch,jet}}{p_{ch,jet} \cdot p_{ch,jet}}$$

# First direct measurement of dead cone effect

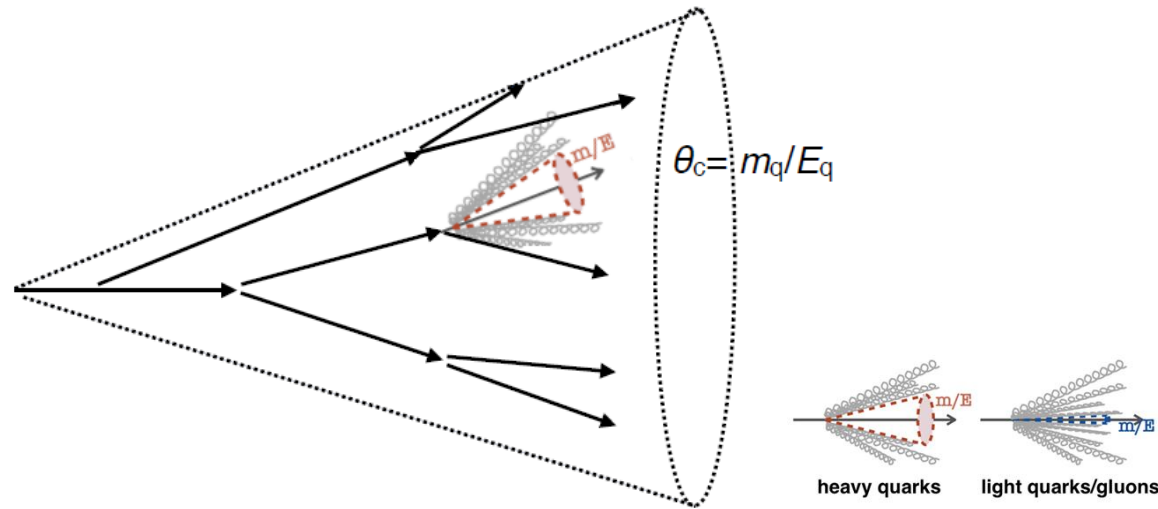

- Suppression of small angle radiation for heavy quarks  $\theta_c = m_q / E_q$ 
  - Fundamental QCD effect never directly observed at colliders

## Evidence of suppression of small angle radiation for D-tagged jets

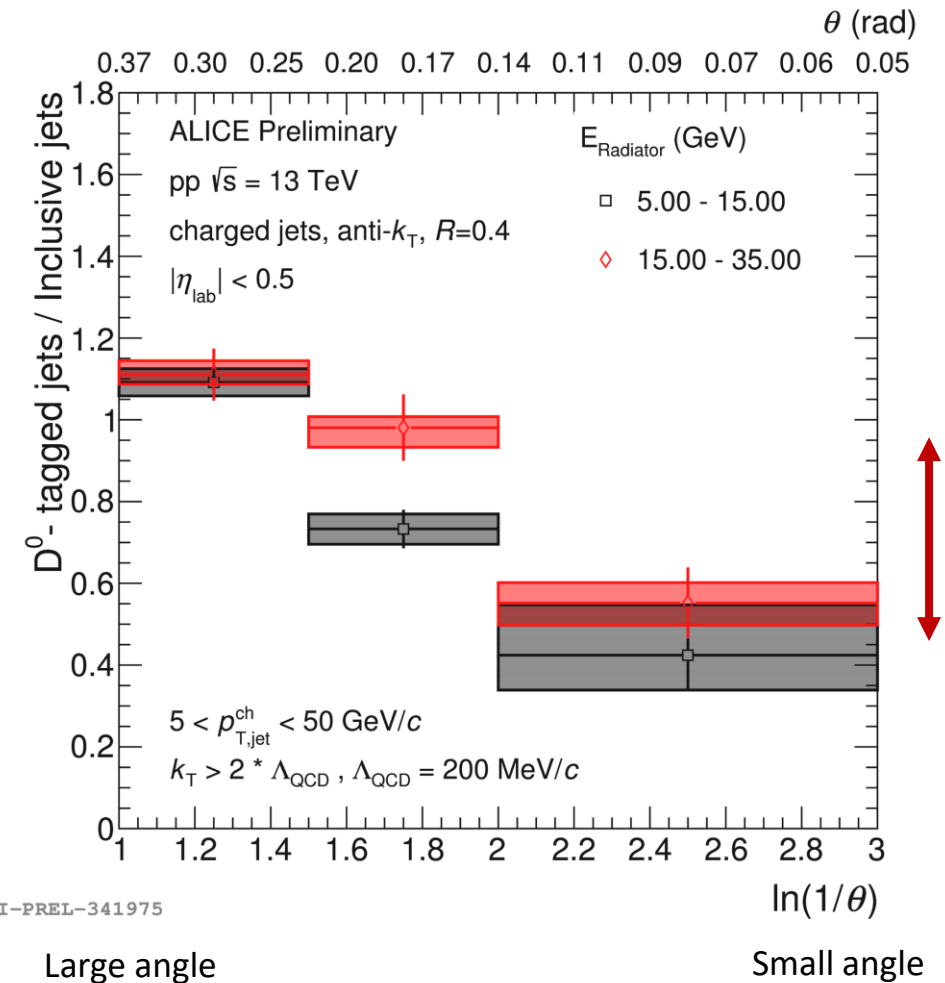

# Number of leading parton splittings



ALICE

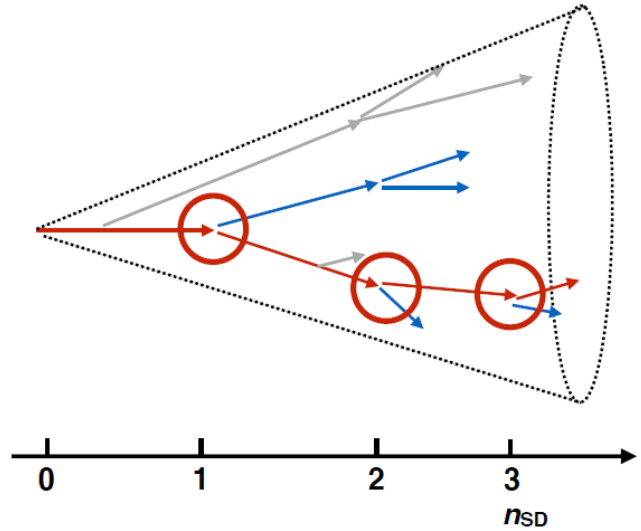

- Total number of splitting  $n_{SD}$  satisfying Soft Drop condition  $z = \frac{p_{T,2}}{p_{T,1} + p_{T,2}} > 0.1$
- Charm jets have fewer splitting than inclusive jets
  - **Harder fragmentation than inclusive jets**
    - Quark vs gluon jets, dead cone effect

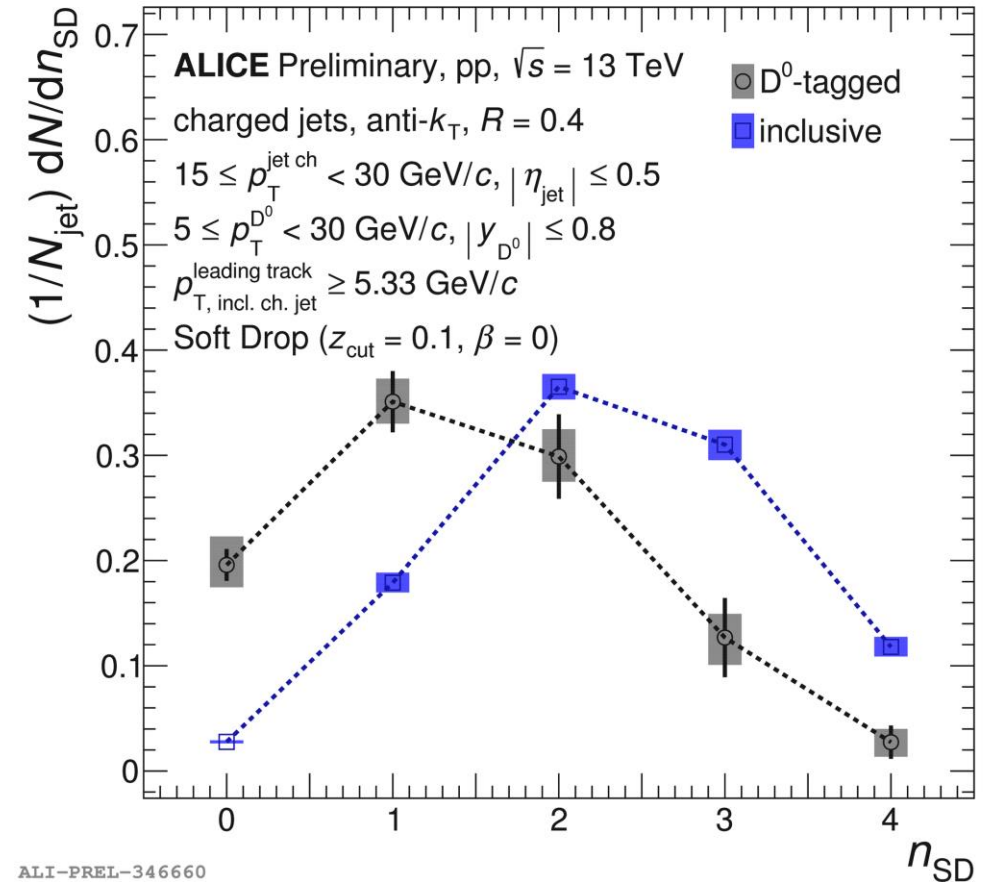

# Summary



- Hadronization in pp is different from  $e^+e^-$  and depends on **multiplicity**
  - **Better descriptions with colour reconnection effect**
  - $\Sigma_c^{0,+,+} / D^0$  is well described **but  $\Xi_c^{0,+} / D^0$  not!**
- Model **with string fragmentation predict harder fragmentation** of D-meson jets than seen in data
- Number of leading **parton splittings for HF jets is smaller** than for inclusive jets
- First **direct measurement of Dead Cone effect** at colliders
  - Will it be different in Pb-Pb?
- **Understanding pp collisions is very important to understand PbPb!**

Thank you for your attention

# What is LHC?

- **The Large Hadron Collider (LHC)**
  - Most powerful particle accelerator in the world
    - started up on 10 September 2008
  - 27-kilometre ring of superconducting magnets
    - 1232 dipole magnets (15m long, bending)
    - 392 quadrupole magnets (5-7m long, focusing)
  - two high-energy particle beams with crossing at 4 main experiments
    - ATLAS, ALICE, CMS, LHCb
- **Conseil Européen pour la Recherche Nucléaire (CERN)**
  - European laboratory for particle research
  - Founded in 1954 on the border of Switzerland and France near Geneva
  - **23 Member States (including Slovakia and Czech Republic)**
  - Some Achievements
    - 1983 - W and Z particles discovered
    - 1986 - Heavy-ion collisions begin
    - 1995 - First antiatoms produced: antihydrogen
    - 2012 - Higgs boson discovered
    - 2015 - Discovery of pentaquarks
    - 2019 - Discovery of tetraquark or meson-meson molecule (not know which yet)



CERN's Accelerator Complex

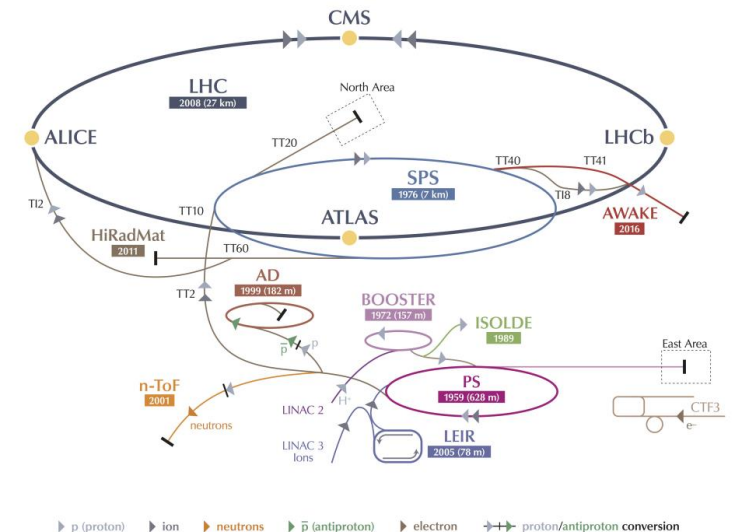

LHC Large Hadron Collider SPS Super Proton Synchrotron PS Proton Synchrotron  
 AD Antiproton Decelerator CTF3 Clic Test Facility AWAKE Advanced WAKEfield Experiment ISOLDE Isotope Separator OnLine DEvice  
 LEIR Low Energy Ion Ring LINAC LINear ACcelerator n-ToF Neutrons Time Of Flight HiRadMat High-Radiation to Materials

© CERN 2013

# Introduction to High Energy Physics

- **Introduction to High Energy Physics units**

- Mass:  $1 \text{ eV}/c^2 = 1.78 \cdot 10^{-36} \text{ kg}$
- Momentum:  $1 \text{ eV}/c = 1.53 \cdot 10^{-28} \text{ kgms}^{-1}$
- Temperature:  $1 \text{ eV}/k_B = 11604 \text{ K}$
- Time:  $1 \text{ eV}^{-1} \hbar = 6.58 \cdot 10^{-16} \text{ s}$
- Length:  $1 \text{ MeV}^{-1} \hbar c = 197 \text{ fm}$
- We will use natural units:  $c = \hbar = k_B = 1$
- And transverse momentum:  $p_T = \sqrt{p_x^2 + p_y^2}$ , where  $p_z$  is in the beam direction

- Particles are composed of **quarks**

- **Baryons** (qqq)
  - Ordinary matter is from the 1<sup>st</sup> generation of quarks
    - Proton (uud), neutron (udd)
- **Mesons** (q $\bar{q}$ )

- **Heavy flavour are c and b quarks**

- Massive!  $m_c \sim 1.2 \text{ GeV}/c^2$ ,  $m_b \sim 4.5 \text{ GeV}/c^2$

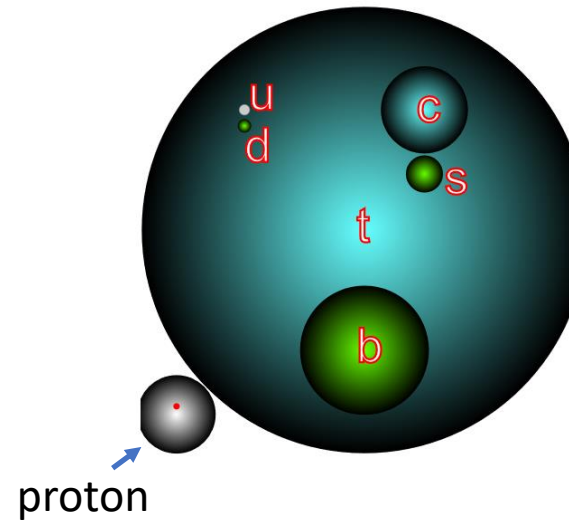

## Comparison of quark masses

Incnis Mrsi  
 (https://commons.wikimedia.org/wiki/File:Quark\_masses\_as\_balls.svg),  
 „Quark masses as balls“, https://creativecommons.org/licenses/by-sa/3.0/legalcode

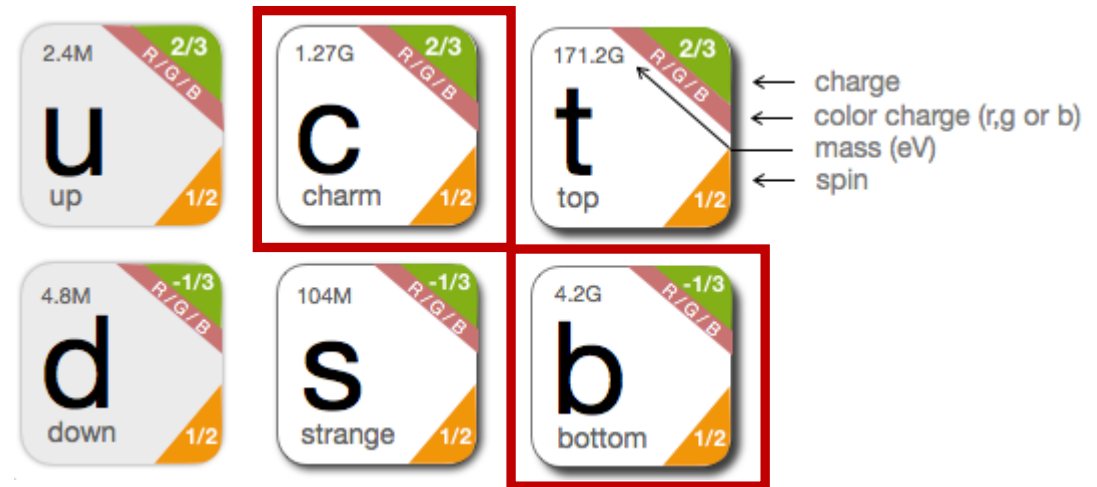

## Heavy Flavour

# Parton energy loss – Nuclear Modification Factor



ALICE

- Natural way how to see the medium influence would be to compare the “vacuum” proton-proton (pp) collisions and the “medium” ion-ion collisions (AA) scaled by “geometrical” factor –

## Nuclear modification factor ( $R_{AA}$ ):

- $R_{AA}(p_T) = \frac{dN_{AA}/dp_T}{\langle T_{AA} \rangle d\sigma_{pp}/dp_T}$ 
  - Nuclear overlap function  $T_{AA}$  encodes collision geometry
- If  $R_{AA} = 1$  no nuclear effects
- If  $R_{AA} \neq 1$  nuclear effects
- HF tag
  - Challenging, requires good tracker
  - D meson  $c\tau \sim 100 - 300 \mu m$ , B meson  $c\tau \sim 450 \mu m$
  - HF particles decays by weak decays – they are not lost during the evolution
    - Momentum loss mainly

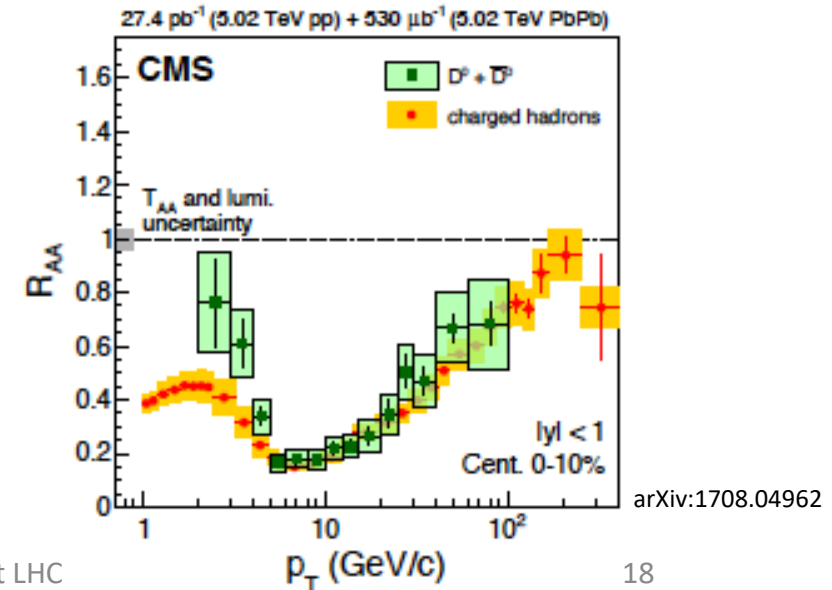
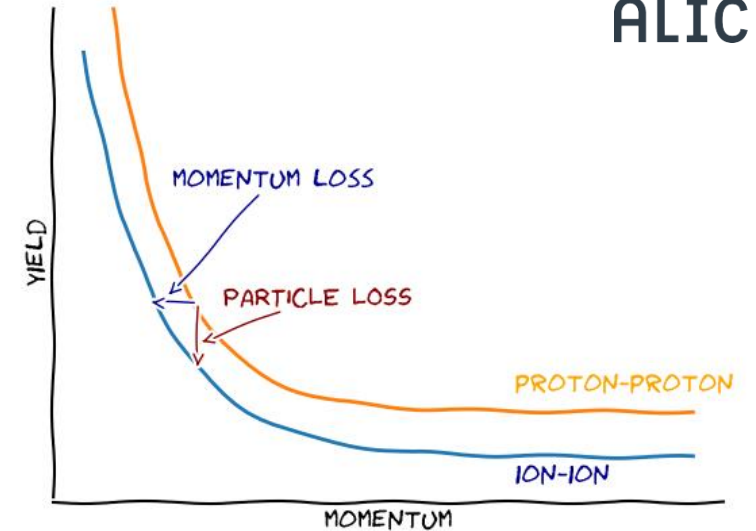

# Energy Loss in Quark-Gluon Plasma

- A particles/jet must push through the hot, dense, strongly interacting fireball
- **Energy loss in medium**
  - **Collisional** – even for HF this can be significant!
  - **Radiative** – emitting a gluon
    - **Colour charge (Casimir factor)**
      - Different for quarks ( $C_R = 4/3$ ) and gluons ( $C_R = 3$ )
    - **Quark mass (Dead cone effect)**
      - $E_g > E_{u,d,s} > E_c > E_b$
    - **Path length in the medium**
  - => **Jet quenching**
- Study the parton energy loss in the QGP
  - Modified **fragmentation** – parton shower
  - Effects of **recombination** and **colour reconnection** on hadronization
  - **Flavour and mass dependence**
  - **Quark (HF jets) vs gluon (other jets) jet difference**

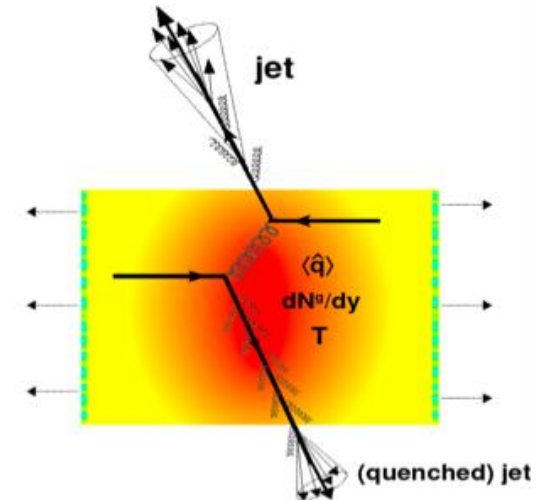

arXiv:0902.2488

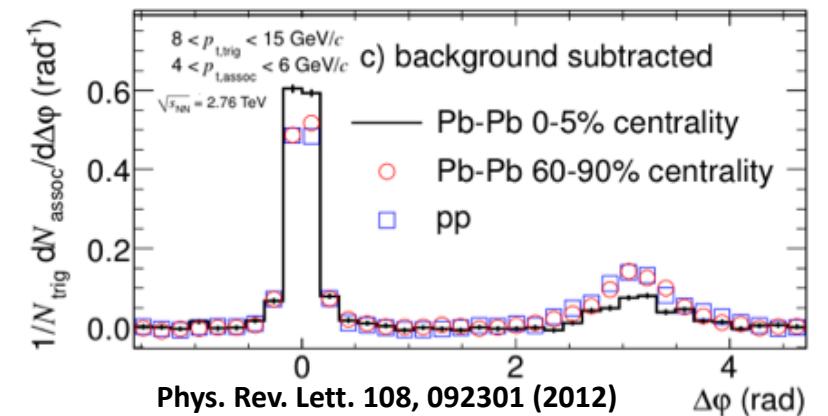

# Nuclear Modification Factor

- To probe the in-medium energy loss (scattering + radiation)
  - Depend on colour charge (Casimir factors), mass (Dead cone), path length in medium
- $R_{AA}(\mathbf{D}) > R_{AA}(\text{ch. part.})$  at  $p_T < 4 \text{ GeV}/c$ 
  - Harder  $p_T$  spectra for charm particles and different fragmentation functions
  - Different recombination and radial flow contribution
- Indication of less nuclear modification for  $\mathbf{D_s^+}$  and  $\mathbf{\Lambda_c^+}$
- Similar modification at high  $p_T$
- Nuclear modification factor ( $R_{AA}$ ):
  - $R_{AA}(p_T) = \frac{dN_{AA}/dp_T}{\langle T_{AA} \rangle d\sigma_{pp}/dp_T}$ 
    - Nuclear overlap function  $T_{AA}$  encodes collision geometry
  - If  $R_{AA} = 1$  no nuclear effects
  - If  $R_{AA} \neq 1$  nuclear effects

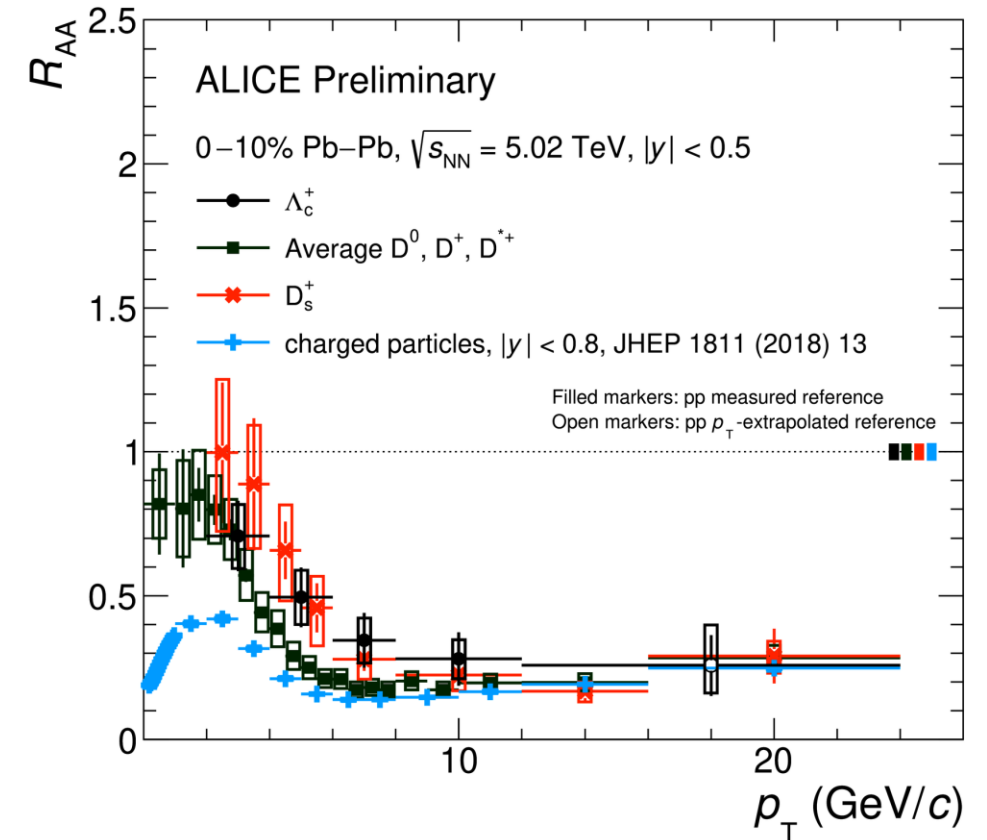

ALI-PREL-330734

# Strange D mesons

- Effect of **coalescence/recombination**
  - Charm quark will pick up other quark and create a particle
- Strange meson / non-strange meson ( $D_s/D$ )
  - QGP temperature near the energy of creating  $s\bar{s}$  pair
    - Strangeness enhancement
  - Recombination in strangeness rich environment
- **Supports hypothesis of relevant contribution of coalescence in charm hadronization in Pb-Pb collisions**

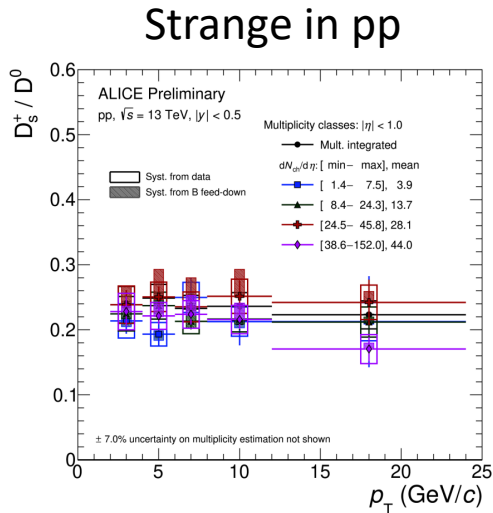
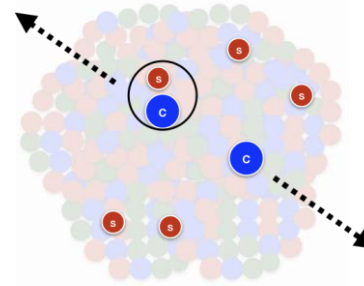

ALI-PREL-336402

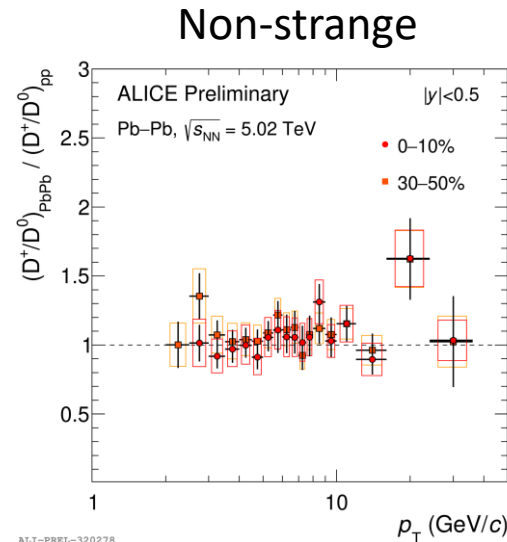

ALI-PREL-320278

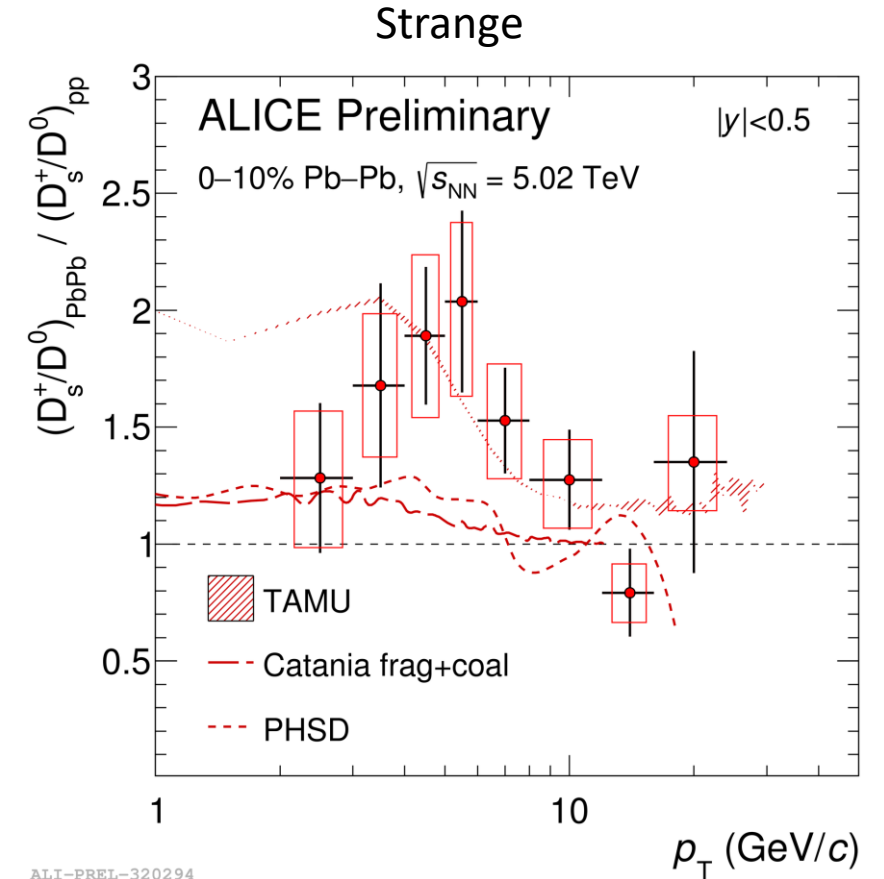

ALI-PREL-320294