

MECHANICAL ENGINEERING OF ACCELERATOR COMPONENTS

Antti Kolehmainen
Tommi Mikkola
Tuukka Lehtinen
on behalf of CERN EN/MME



ENGINEERING
DEPARTMENT

CERN EN-MME GROUP

“The mandate of the MME group is to provide to the CERN community specific engineering solutions combining mechanical design, fabrication and material sciences.”

- We are around 150 people
- We do:
 - Material development and mechanical and geometrical measurements
 - Engineering calculations and simulations
 - Mechanical design
 - Production and sourcing

CERN's Accelerator Complex

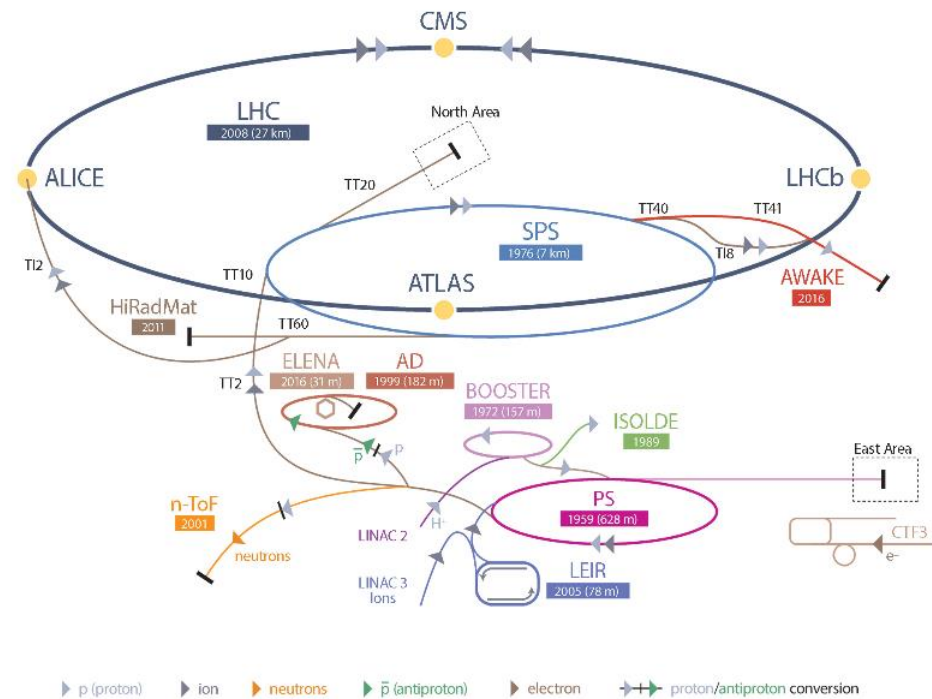

MECHANICAL DESIGN

DESIGN INPUTS

Page 4 of 11

1. INTRODUCTION
This document represents the basic requirements for the 3D model of the ELENA MBR design, done in CATIA. It further represents the interface document between the magnet work package and the design office.

2. NOMENCLATURE
All the parts and assemblies established for this magnet shall follow the same nomenclature as the prototype (i.e. AD_MBHEKXXXX, where XXXX is a consecutive number).

3. SOFTWARE
For this design it has been agreed that the software used will be CATIA V5. The release version may change according to CERN procedures.

4. COORDINATE SYSTEM
The coordinate system to be observed shall be the following:

Right handed, orthogonal coordinate system to be used

- z-axis: tangential to the beam in the direction of the beam in the center of the magnet
- y-axis: vertical in the opposite direction to gravity, 0 at the magnet center
- x-axis: According to a right-handed coordinate system perpendicular to x and z (0 at mechanical pole center)

An example for the coordinate system can be found under Figure 1.

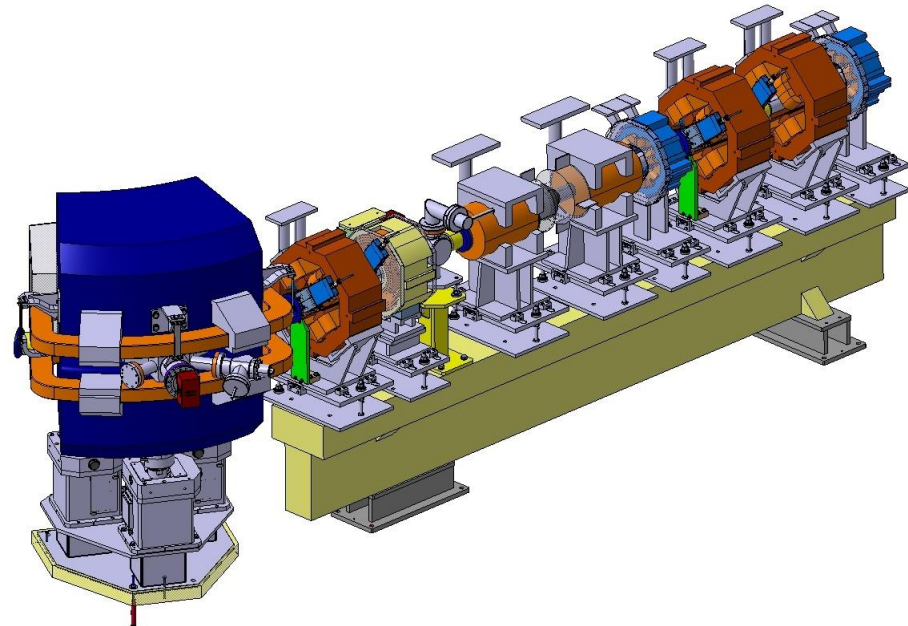

CLIENT SPECIFICATION
FOR THE DEVICE

AVAILABLE SPACE FOR THE DEVICE

ALL PARTIES CONCERNED ARE INFORMED

MECHANICAL DESIGN

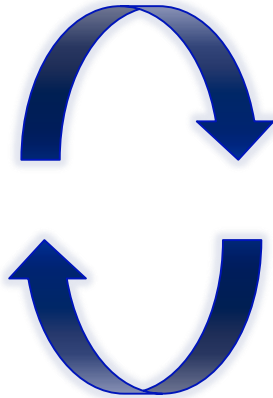
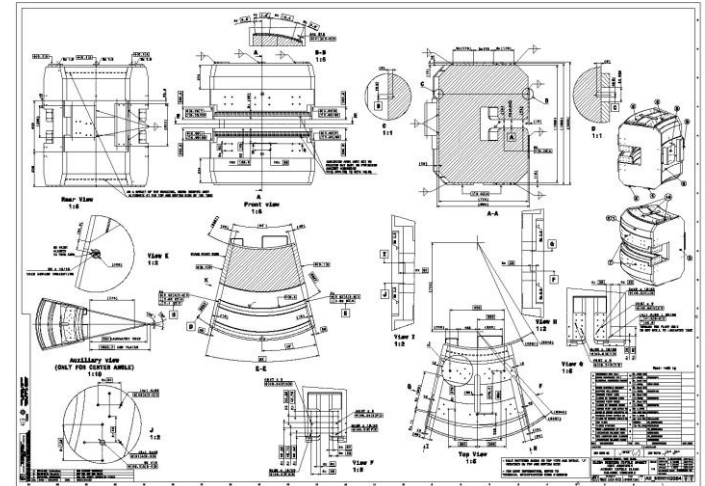
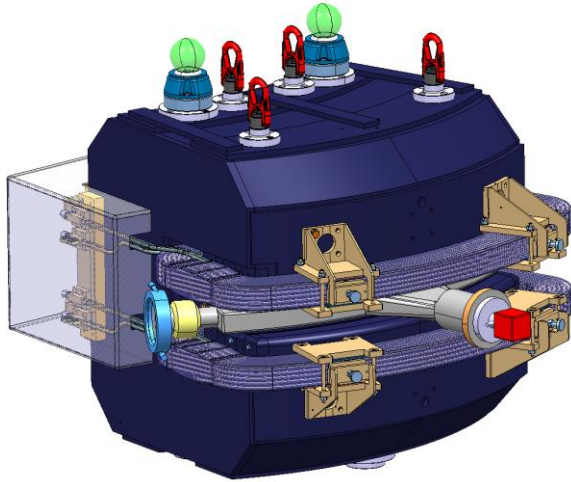

ITERATIONS:

- CLIENT
- ANALYSIS
- INTEGRATION
- MANUFACTURING

DELIVERABLES:

- 2D DRAWINGS
- 3D MODELS
- SUPPORT DOCUMENTS

MATERIAL DEVELOPMENT AND MEASUREMENTS

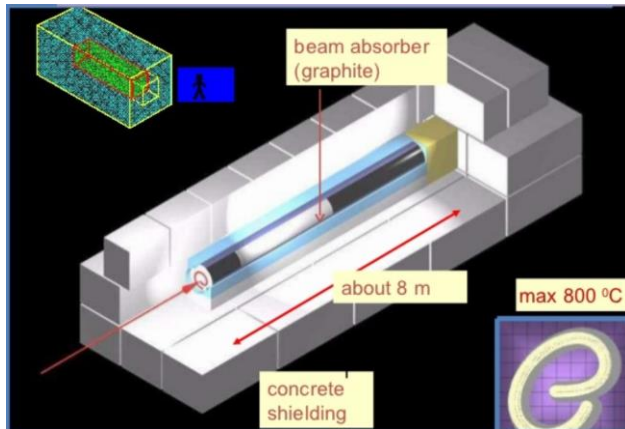

MATERIAL DEVELOPMENT:

- GRAPHITES FOR BEAM IMPACTS
- STAINLESS STEEL ALLOY FOR PERMEABILITY



MECHANICAL MEASUREMENTS:

- Non Destructive Test: X-RAY TESTS FOR THE LHC DIPOLE MAGNETS
- Destructive Test: TENSILE TEST OF MATERIALS



GEOMETRICAL MEASUREMENT OF COMPONENTS TO VERIFY COMPLIANCE TO THE SPECIFICATIONS

ENGINEERING CALCULATIONS

SAFETY ASSESMENT, GUIDES DESIGN WORK AND VERIFIES THAT A DESIGN MEETS ITS REQUIREMENTS

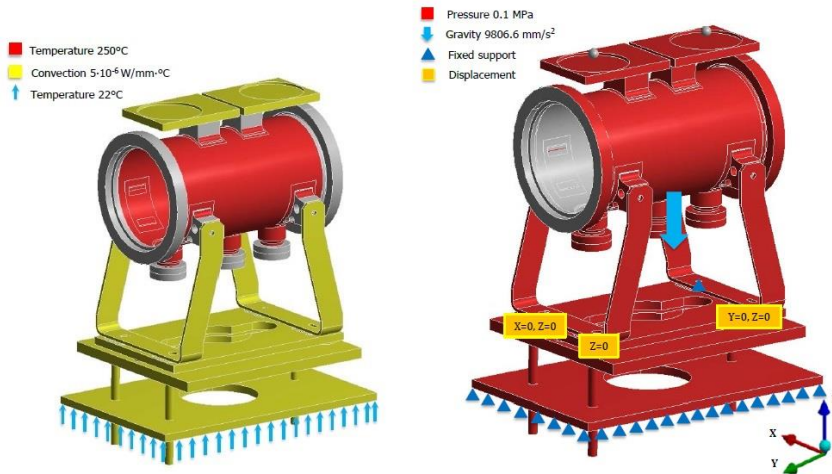

BOUNDARY CONDITIONS



FUNCTIONAL DEVICE

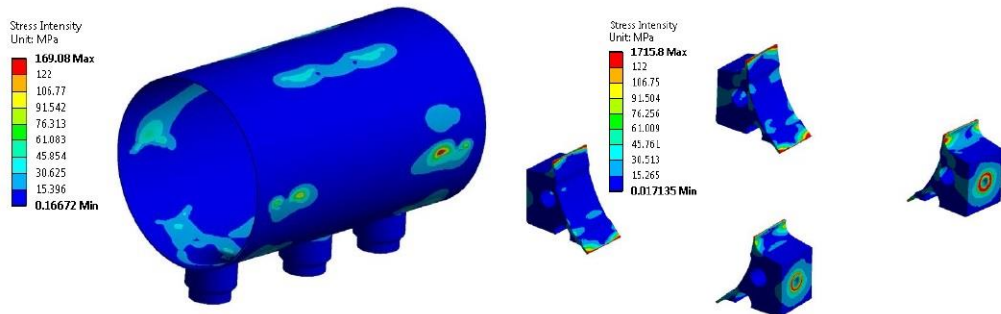

ANALYSIS RESULTS

PRODUCTION

EN/MME HAS THREE WORKSHOPS

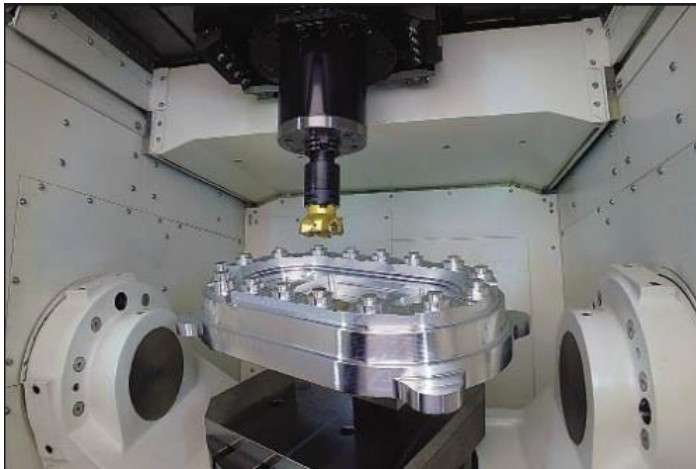

- REMOVE MATERIAL BY CUTTING – ONLY METAL MATERIALS BY EN/MME
- ADDING DEGREES OF FREEDOM ALLOWS MORE COMPLEX GEOMETRIES
- ELECTRICAL DISCHARGE MANUFACTURING – ELECTRICAL ARCS REMOVE MATERIAL



- FORM MATERIAL
 - BEND / ROLL / DRAW
- 3D PRINTING IN USE – AND IN CONSTANT DEVELOPMENT!

PRODUCTION AND OUTSOURCING



- **WELDING**
 - MELT THE PARTS TO BE JOINED LOCALLY – FILLER METAL MAY BE ADDED
- **BRAZING**
 - JOINED PARTS DO NOT MELT, ONLY FILLER METAL. DIFFERENT MATERIALS CAN BE JOINED

- **PURCHASE SIMPLE COMPONENTS AND LARGE SERIES FROM INDUSTRY**

? / !

QUESTIONS? / THANK YOU FOR YOUR ATTENTION!



ENGINEERING
DEPARTMENT