



European School of Instrumentation
in Particle & Astroparticle Physics



European Scientific Institute

Detector Simulation Visualisation

Witek Pokorski
Alberto Ribon
CERN

10-11.02.2020



Introduction to Geant4 Visualization

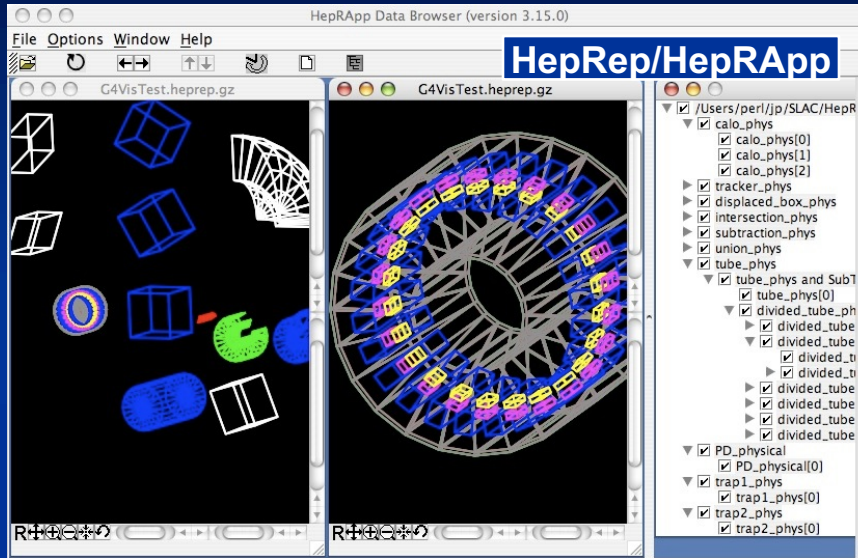

This lecture is entirely based on Michael Kelsey (SLAC) slides made by Joseph Perl (SLAC)

So many options, it needs three title pages

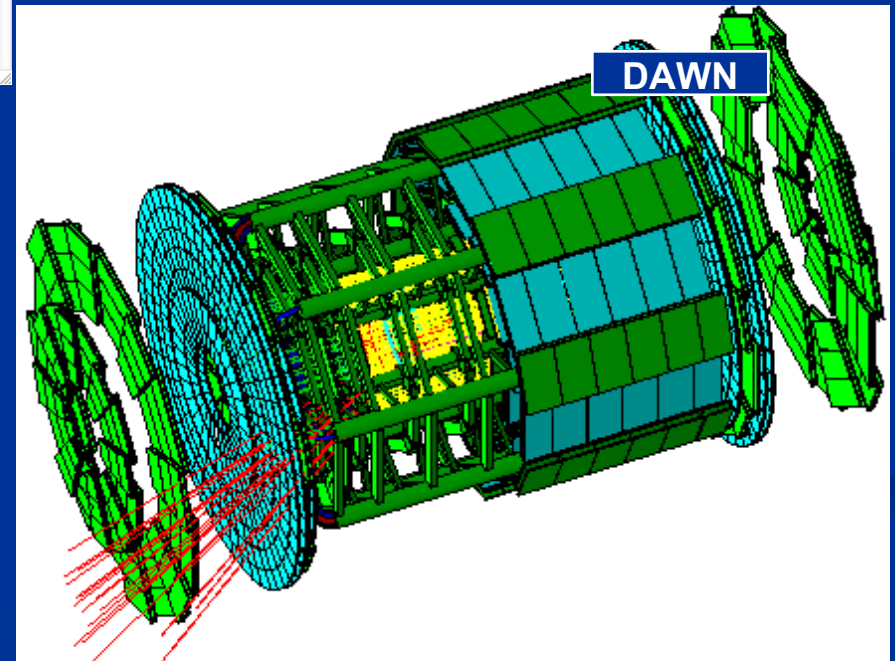
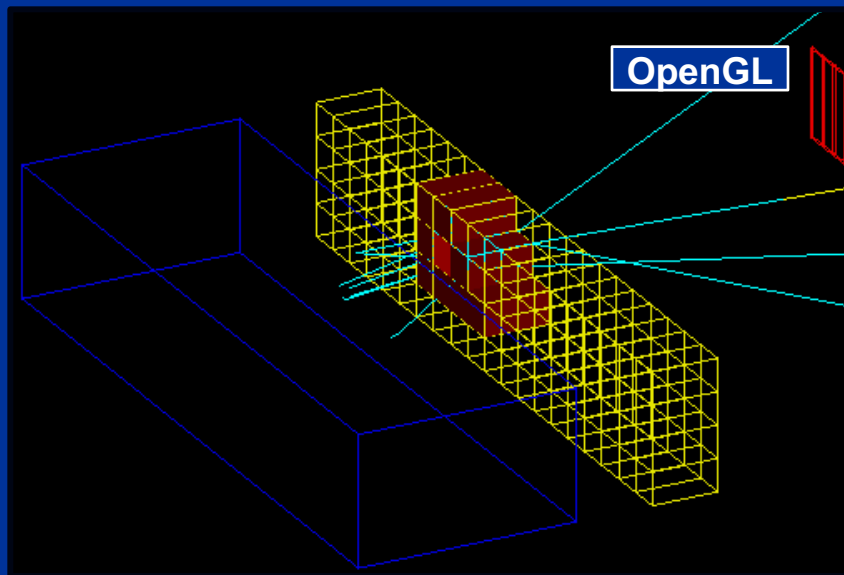

Introduction to Geant4 Visualization

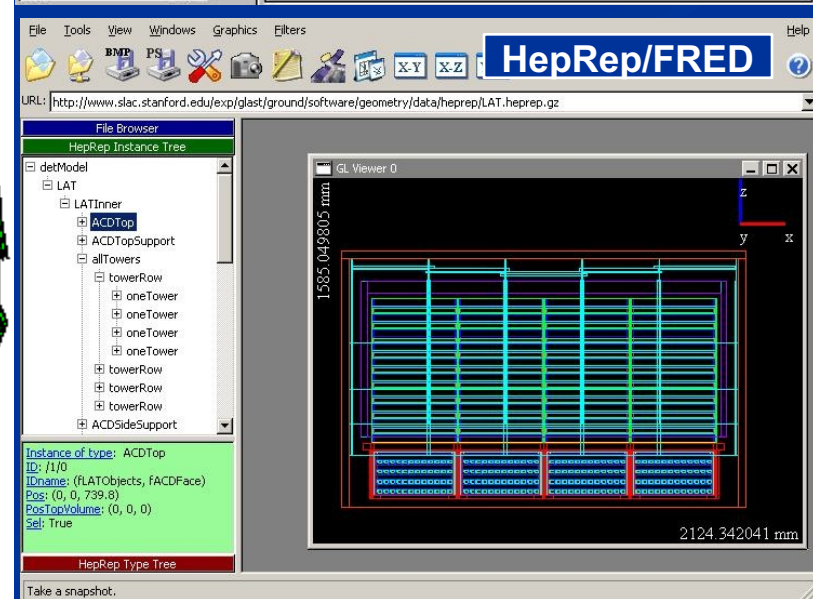
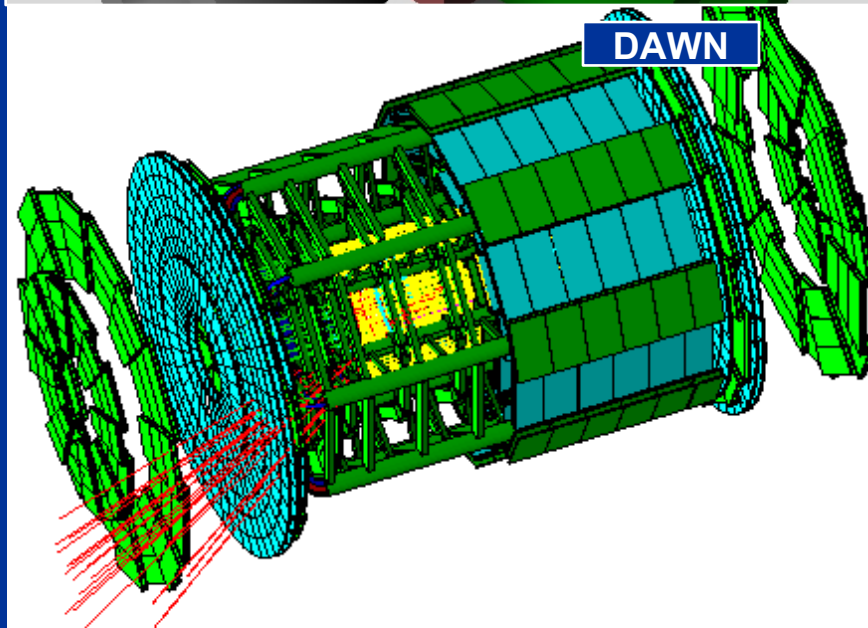
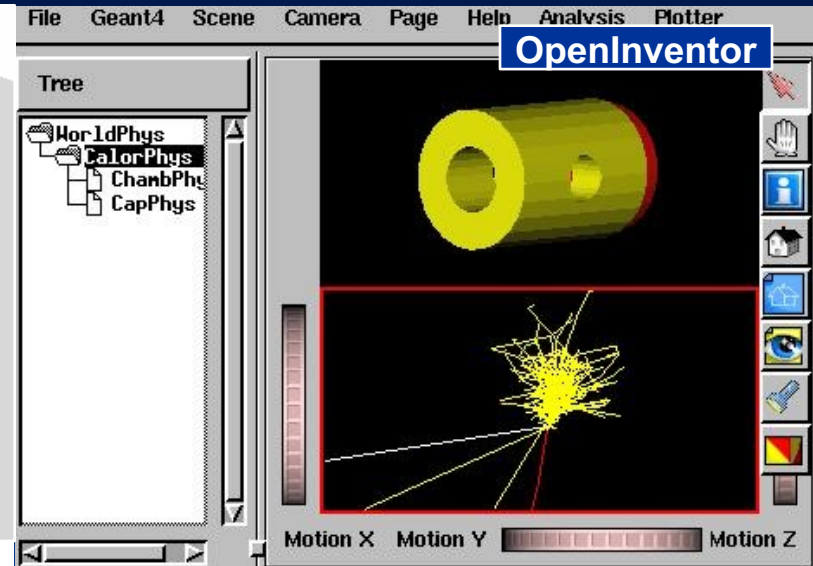
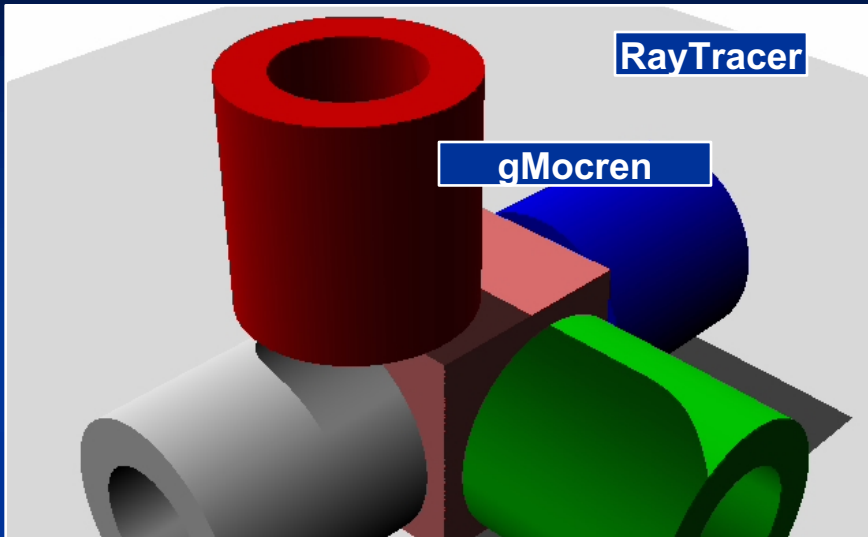

Introduction to Geant4 Visualization

The image displays two windows from the Geant4 visualization environment. The top window, titled "G4UI Session", contains a "viewer-1 (OpenGLStoredQt)" panel showing a 3D scene of various colored geometric shapes (cubes, spheres, cylinders) on a black background. To the left of this viewer is a control panel with sections for "Vis parameters", "Viewer components", and "Help". A search bar is present, and a command list shows: `Command /vis/viewer/set/hiddenMarker` with the guidance: "If true, closer objects hide markers. Otherwise, markers always show." The bottom window, titled "gMocren", features a large 3D model of a patient's head and neck in a semi-transparent red and blue mesh. To its right are three smaller 2D dose distribution plots labeled "Dose: 0keV", showing axial, coronal, and sagittal views. At the bottom left of the gMocren window is a graph with "Patient" and "Dose" axes, showing a dose profile. On the bottom right, there are radio buttons for "CT", "Density", "Opacity", and "Color", along with "Load" and "Save" buttons. A copyright notice at the bottom left of the gMocren window reads: "(C) 2005-2008 JST/CREST, Rits, AIT and KGT Inc. All Rights Reserved".

How this Document Fits with Other Tutorial Materials

- This presentation can be used on its own, but gives the most comprehensive introduction to Geant4 visualization when used as part of the following full set of documents:
 - [Introduction to Geant4 Visualization](#)
 - [Geant4 Installation Guides](#)
 - [Geant4 Visualization Tutorial using the HepRApp HepRep Browser](#)
 - [Geant4 Visualization Tutorial using the DAWN Event Display](#)
 - Geant4 Visualization Tutorial using the OpenGL Event Display
 - Geant4 Visualization Commands
 - Geant4 Advanced Visualization
 - See the URLs at the end of this presentation
- This presentation discusses eight visualization drivers:
 - OpenGL
 - OpenInventor
 - HepRep
 - DAWN
 - VRML
 - RayTracer
 - gMocren
 - ASCII Tree

Tutorials

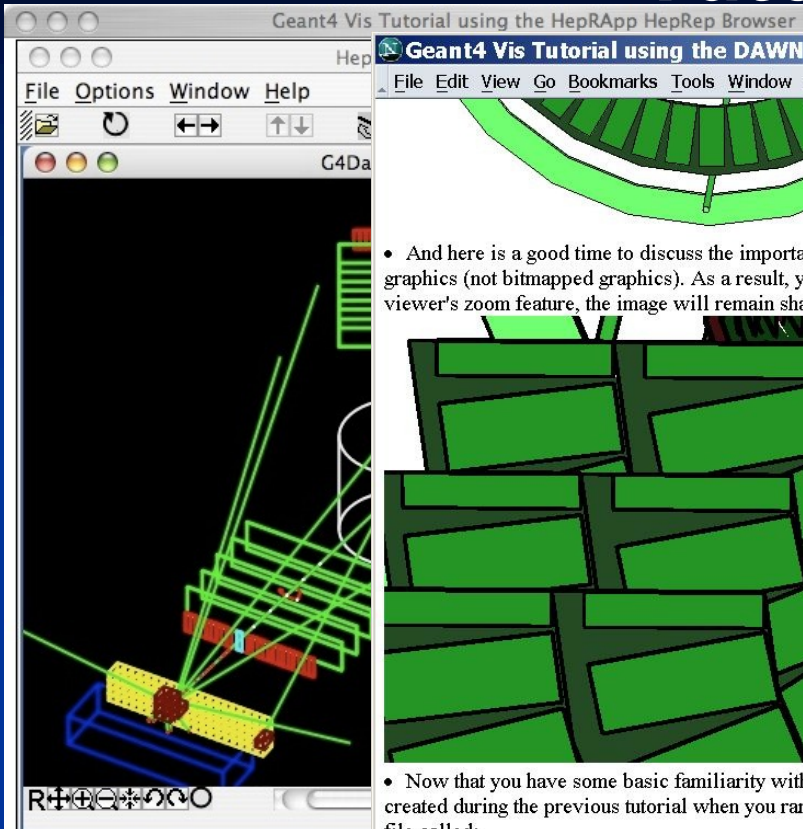

Geant4 Vis Tutorial using the HepRApp HepRep Browser

File Options Window Help

G4Da

- And here is a good time to discuss the important graphics (not bitmapped graphics). As a result, your viewer's zoom feature, the image will remain sharp.



- Now that you have some basic familiarity with DAWN, you can create during the previous tutorial when you ran the file called: `geant4\examples\extended\analysis\A01\g4_01.prim`

Or, if you skipped running Geant4 for now, you can:

- Run DAWN on this file:

```
dawn g4_01.prim
```
- Go to the DAWN GUI's page 1 and select "Load" and "Run".
- On the same page, change "Camera Angle"... "Projection" to "Perspective". You can type in a specific number to clicking on the "Projection" button (the new value).
- You should end up with an image as follows:

Orientation Actions in the PopUp View

To select from among some standard view options, click on the right mouse button (Macintosh users, hit the Command key).

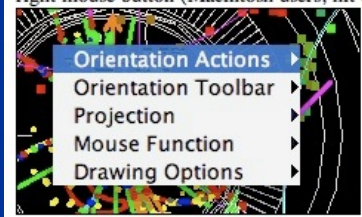

- Orientation Actions
- Orientation Toolbar
- Projection
- Mouse Function
- Drawing Options

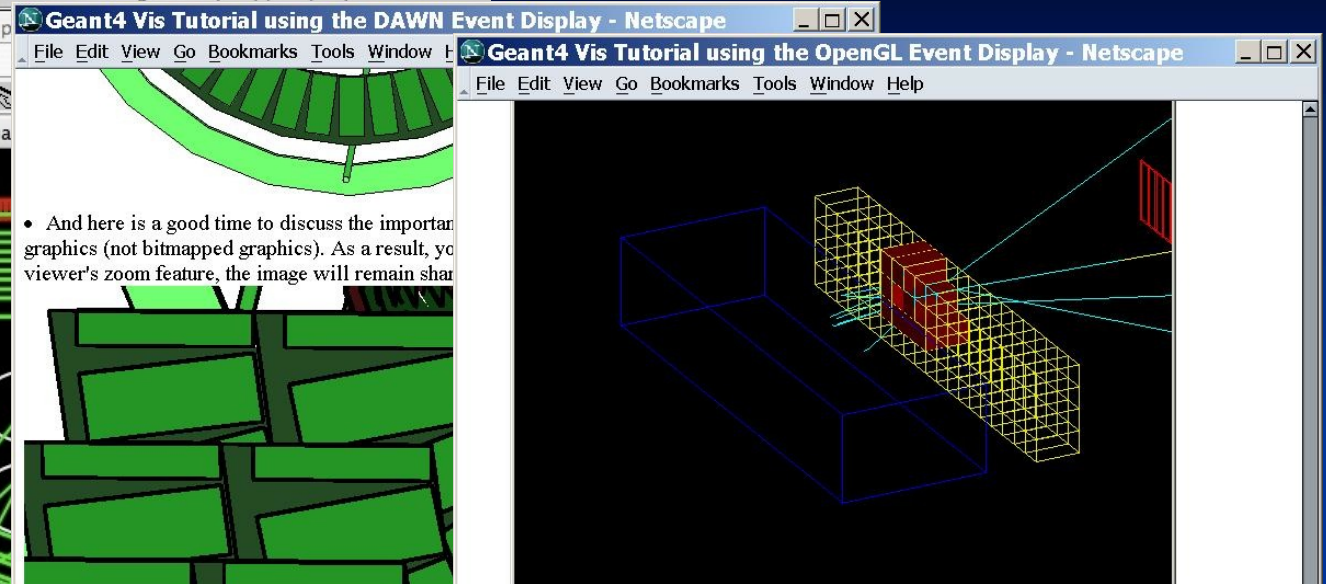

Geant4 Vis Tutorial using the DAWN Event Display - Netscape

File Edit View Go Bookmarks Tools Window Help

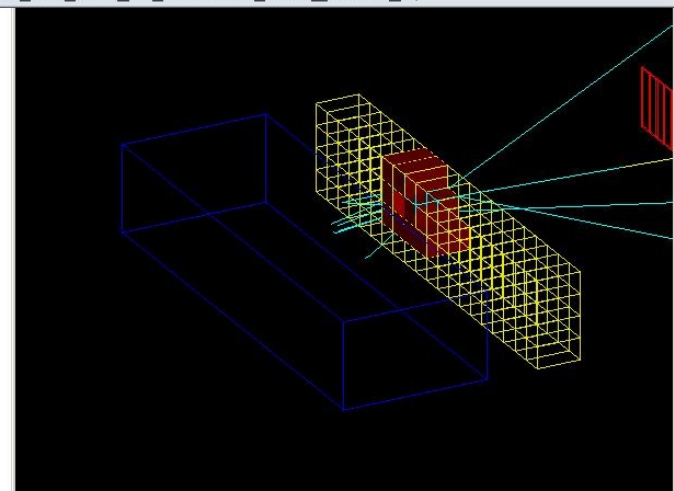

- The output appears as soon as the `/run/beamOn` is complete since a `/vis/viewer/flush` is included automatically at the end of each event.
- One last command for this quick tutorial. You will have noticed in the previous image that the detector was drawn as a wireframe. Change this now by issuing the following command:

```
/vis/viewer/set/style surface  
/run/beamOn 1
```

The detector will then appear as a solid (though it is somewhat transparent, allowing you to still see the tracks passing within).

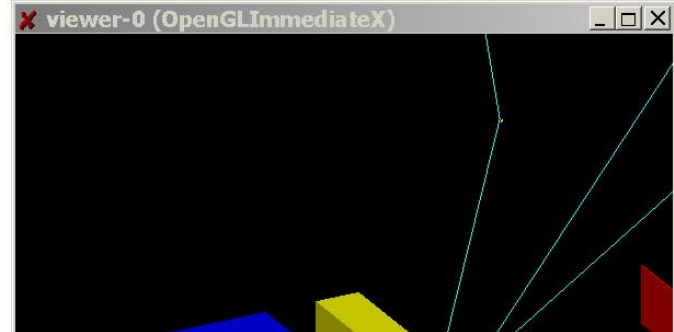

viewer-0 (OpenGLImmediateX)

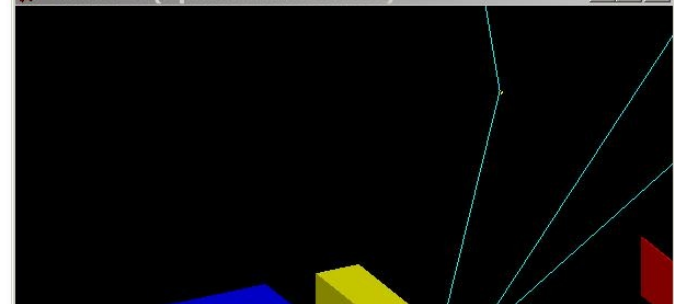

Document: Done (0.481 secs)

What Can be Visualized

- Simulation data can be visualized:
 - Geometrical components
 - Particle trajectories and tracking steps
 - Hits of particles in the geometry
 - Scored energy, dose, etc.
- Other user defined objects can be visualized:
 - Polylines
 - such as coordinate axes
 - 3D Markers
 - such as eye guides
 - Text
 - descriptive character strings
 - comments or titles

Quick Overview of Visualization Driver Choices

- First I'll explain why there are so many visualization driver choices
- Then I'll describe each visualization driver in more detail

Quick response with flexible camera control to study geometries, trajectories and hits

- OpenGL, Qt and OpenInventor

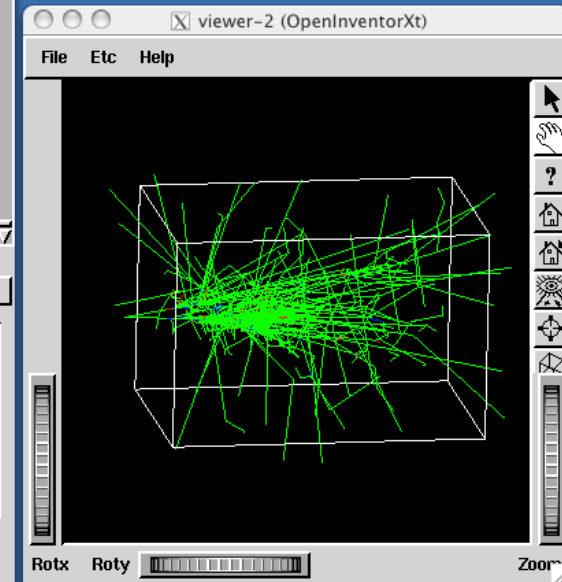
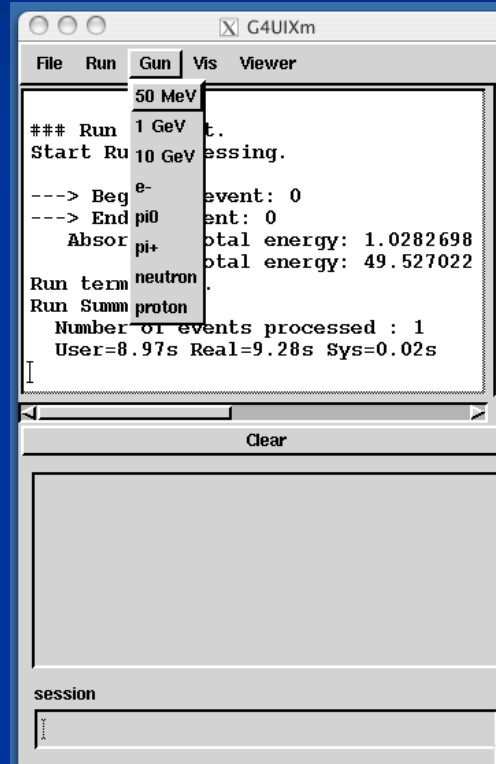
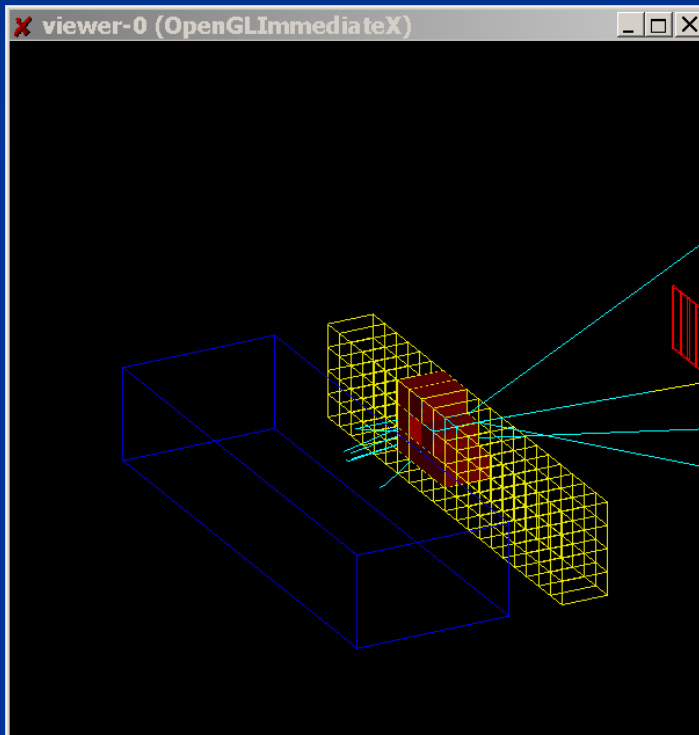

High-quality Output for Publications

- DAWN

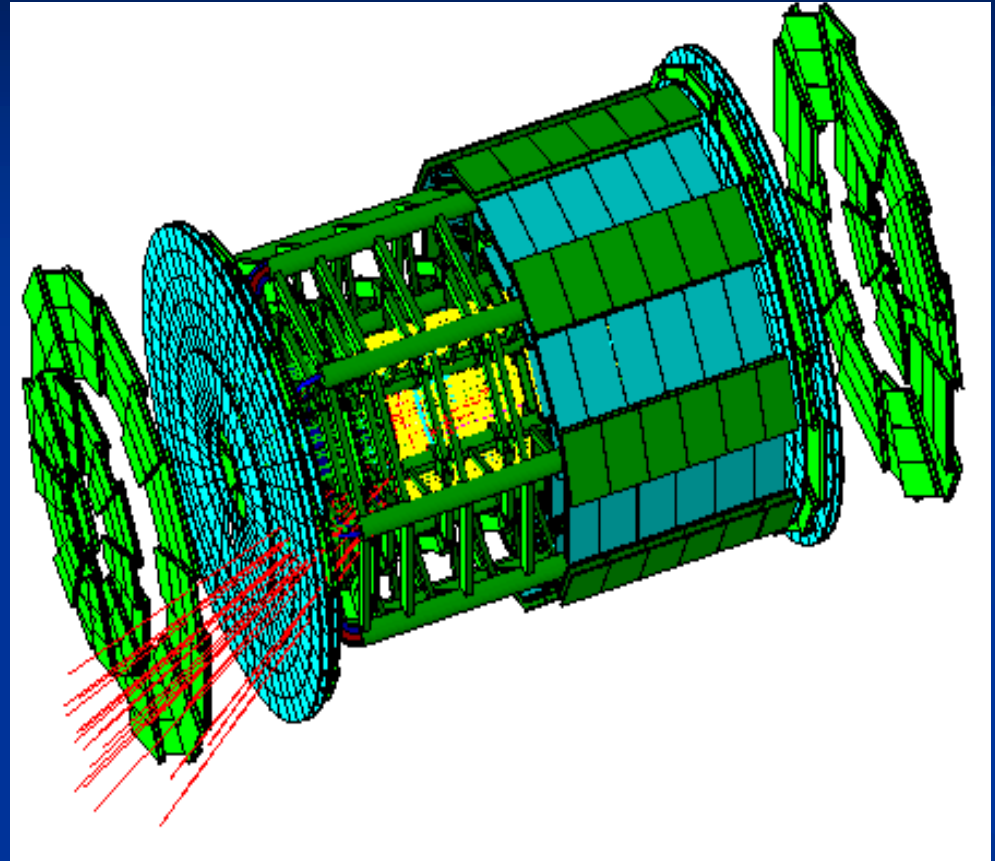
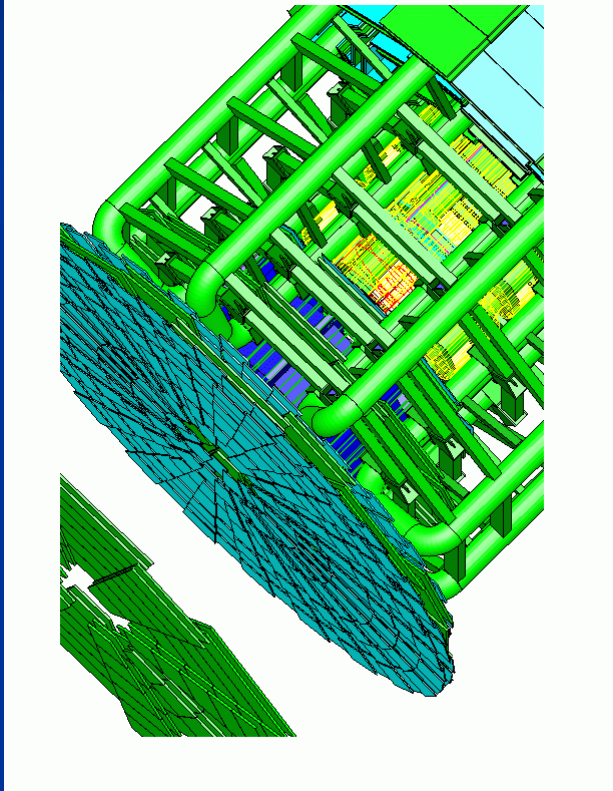

Interactive Picking to Get More Information on Visualized Objects

- HepRep

HepRApp Data Browser (version 3.15.0)

File Options Window Help

G4Data1.heprep.gz

Selected Item(s)

Trajectories[1397]

Attribute	Value
Ch	0 e+
IMag	2.8922 MeV
PDG	22
ID	1533
PN	gamma
PID	1524
IMom-Z	1.21901 MeV
IMom-Y	2.03056 MeV
IMom-X	-1.66001 MeV
NTP	6

Cut Control...

Label Control...

Trajectories[1367]

Trajectories[1368]

Trajectories[1369]

Trajectories[1370]

Trajectories[1371]

Trajectories[1372]

Trajectories[1373]

Trajectories[1374]

Trajectories[1375]

Trajectories[1376]

Trajectories[1377]

Trajectories[1378]

Trajectories[1379]

Trajectories[1380]

Trajectories[1381]

Trajectories[1382]

Trajectories[1383]

Trajectories[1384]

Trajectories[1385]

Trajectories[1386]

Trajectories[1387]

Trajectories[1388]

Trajectories[1389]

Trajectories[1390]

Trajectories[1391]

Trajectories[1392]

Trajectories[1393]

Trajectories[1394]

Trajectories[1395]

Trajectories[1396]

Trajectories[1397]

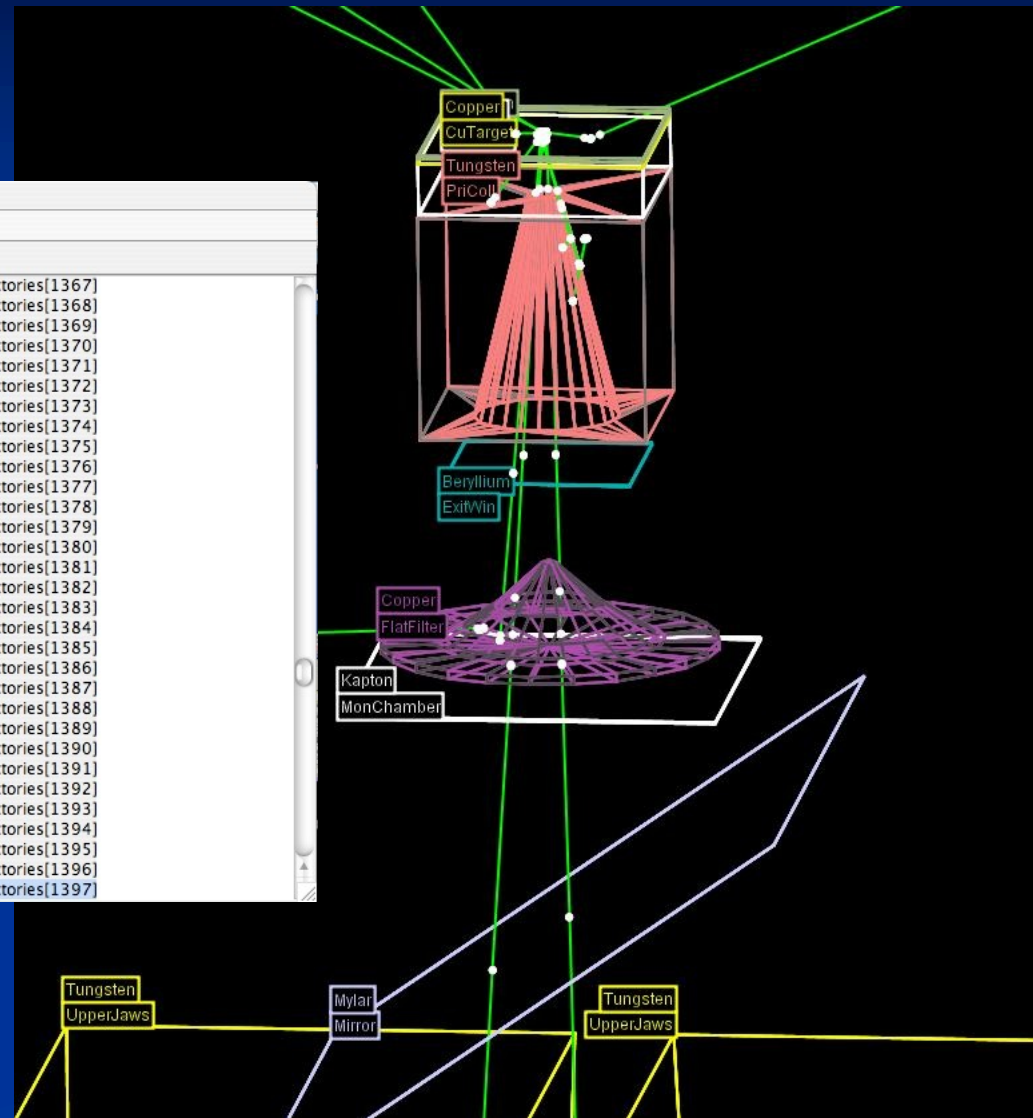

Understand Complex Boolean Solids and Transparent or Reflective Surfaces

- RayTracer

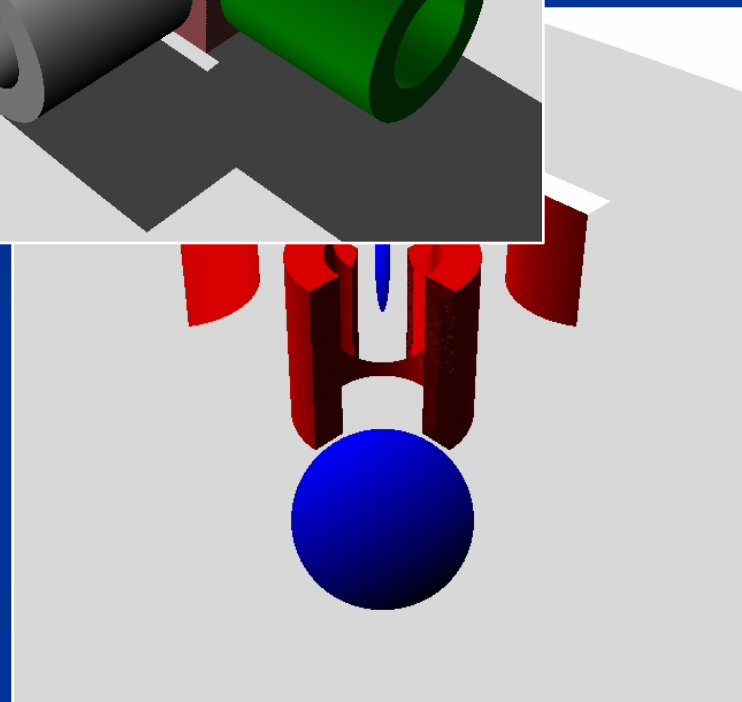
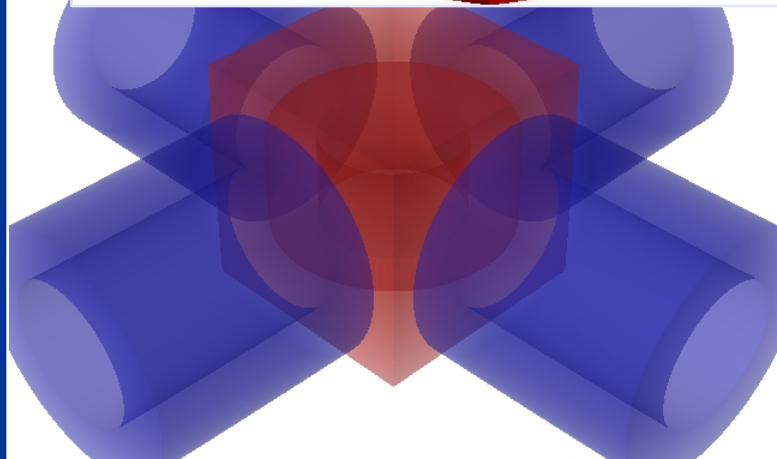
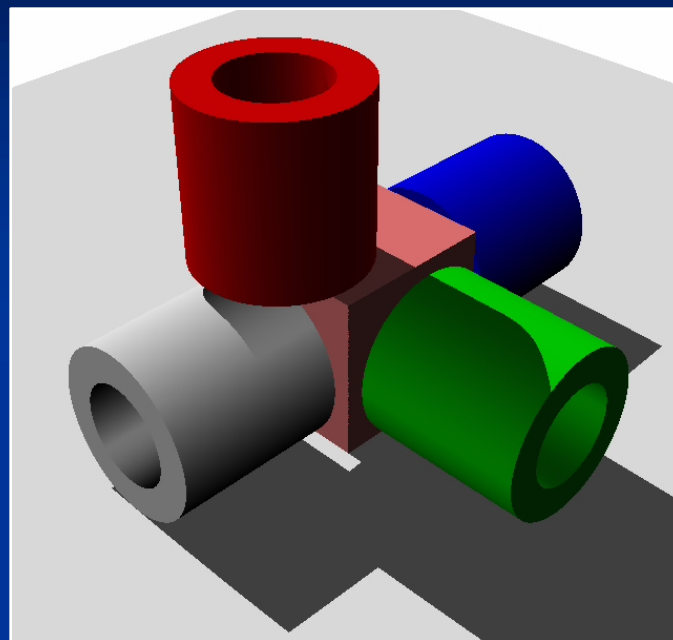
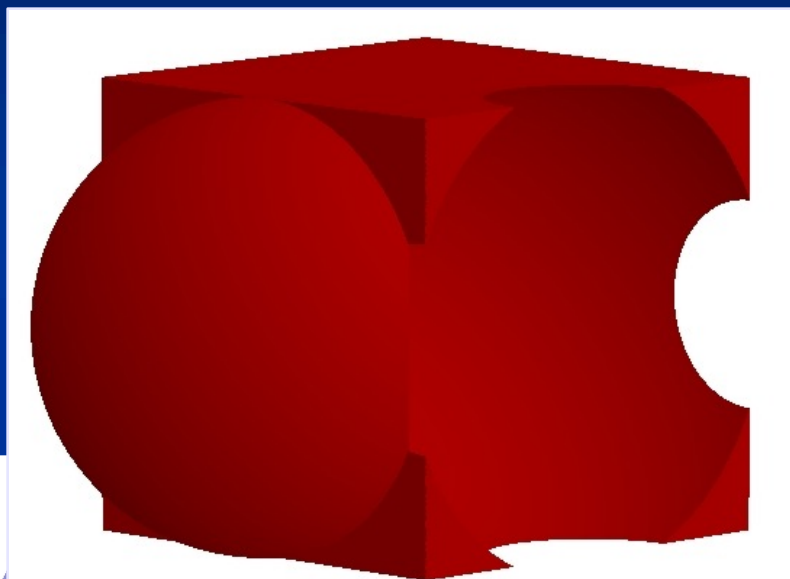

3D Format Suitable for Web Distribution

- VRML

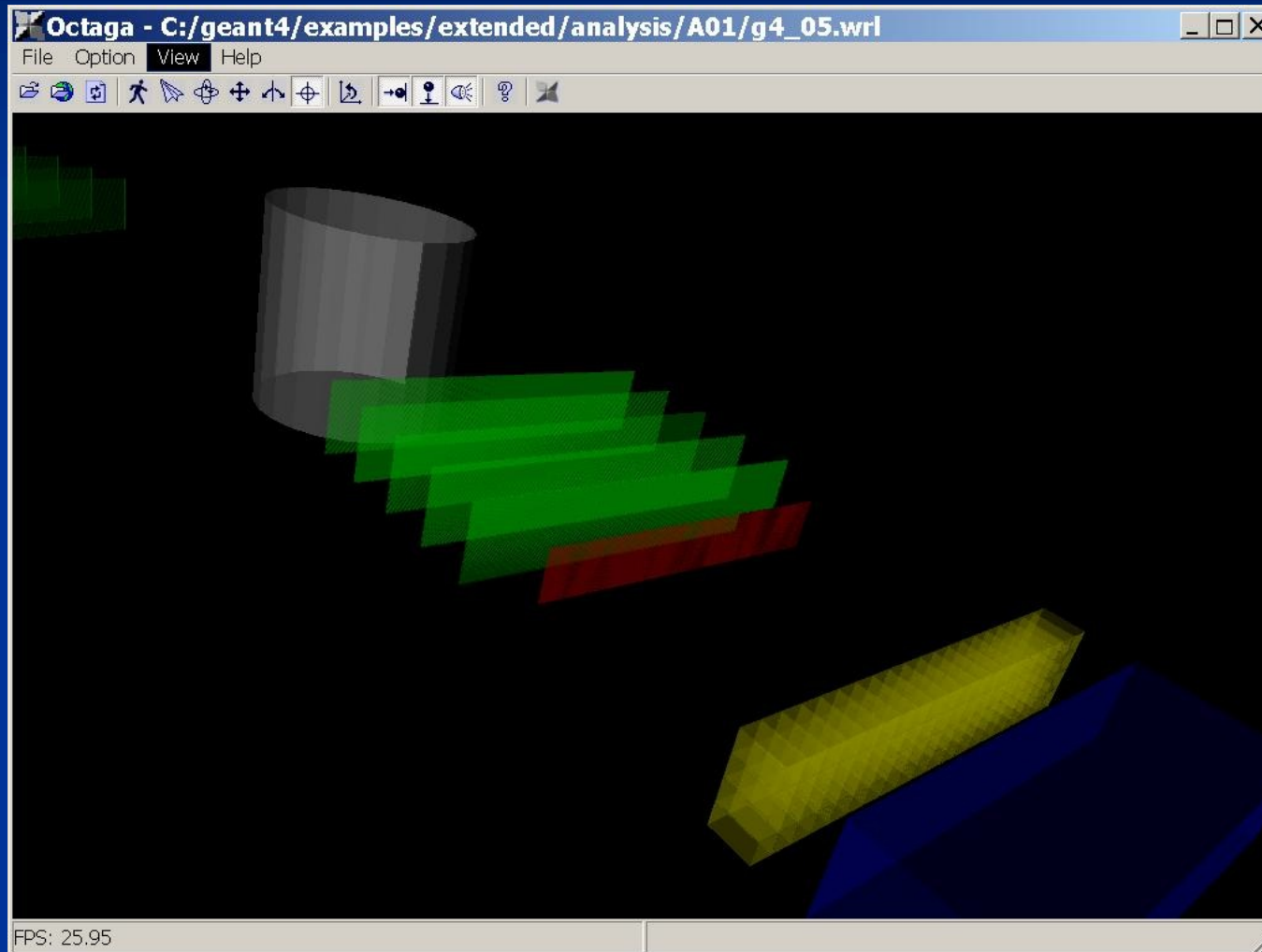

Visualize Volume Data, such as Dose

- gMocren

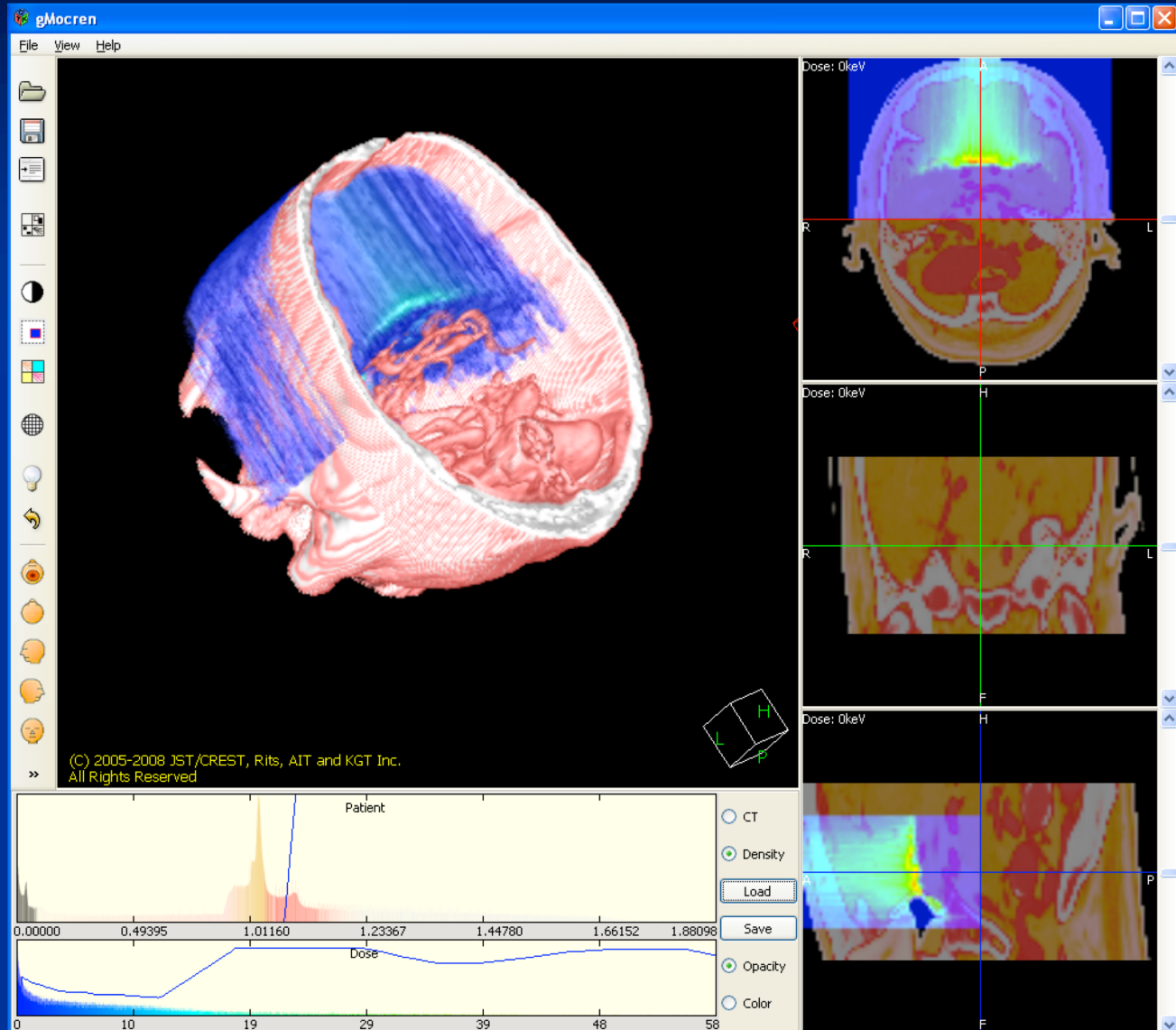

Understand Geometry Hierarchies

- ASCII tree, HepRep

- /vis/ASCIITree/Verbose 4

- /vis/viewer/flush

- "HadCalorimeterPhysical":0 / "HadCalorimeterLogical" / "HadCalorimeterBox"(G4Box), 1.8 m³,

- "HadCalColumnPhysical":-1 (10 replicas) / "HadCalColumnLogical" / "HadCalColumnBox"(G4Box),

- "HadCalCellPhysical":-1 (2 replicas) / "HadCalCellLogical" / "HadCalCellBox"(G4Box),

- "HadCalLayerPhysical":-1 (20 replicas) / "HadCalLayerLogical" / "HadCalLayerBox"(G4Box),

- "HadCalScintiPhysical":0 / "HadCalScintiLogical" / "HadCalScintiBox"(G4Box)

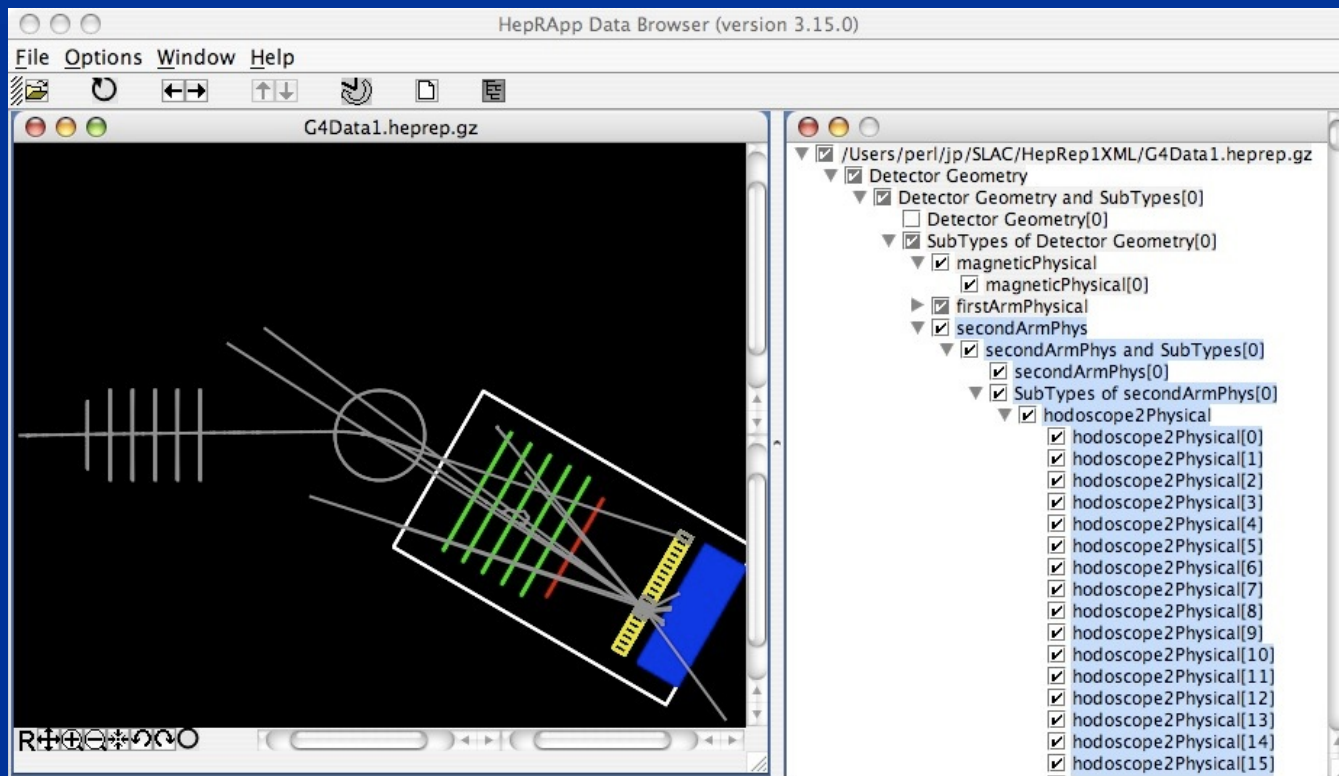

Design by Interfaces

- You may ask why Geant4 has so many different visualization systems.
- This is a natural result of Geant4 being a toolkit and not a single application.
- To support user communities who incorporate Geant4 into their own pre-existing software frameworks, Geant4 visualization is built around a set of well defined interfaces.
 - These interfaces make it straightforward to connect Geant4's core visualization tools to any visualization system
 - able to drive advanced systems that can natively display complex solids such as Geant4's cut cylinders
 - able to drive more basic systems that do not understand such solids (system can ask Geant4 visualization to deconstruct complex solids into simpler polygons)
 - For those users who want a ready-made visualization solution from Geant4, these same interfaces have made it straightforward for us to provide a variety of solutions, each with particular areas of strength.
- Interfaces discussed in detail in: [The Geant4 Visualisation System](#)
J Allison, M Asai, G Barrand, M Donszelmann, K Minamimoto, J Perl, S Tanaka, E Tcherniaev, J Tinslay, Computer Physics Communications, Volume 178, Issue 5, 331-365, 1 March 2008

Eight Visualization Drivers

- No Single Visualization Solution Can Meet all of Our Demands
 - Quick response with flexible camera control
 - High-quality Output for Publications
 - Interactive Picking to Get More Information
 - Complex Boolean Solids and Transparent or Reflective Surfaces
 - 3D Format Suitable for Web Distribution
 - Visualize Volume Data
 - Understand Geometry Hierarchies
- By exploiting the same interface design that we need anyway to support visualization systems of existing frameworks
 - we are able to take advantage of the best features of several different visualization drivers
 - with a common set of user commands
 - and minimal maintenance for many of the drivers
- We take advantage of the best features of many pre-existing visualization systems without having to reinvent those systems.

Controlling Visualization

- Your Geant4 code stays basically the same no matter which driver you use
- Visualization is performed either with commands or from C++ code
 - For the present tutorial, we confine ourselves to command-driven visualization.
- Some visualization drivers work directly from Geant4
 - OpenGL
 - OpenInventor
 - RayTracer
 - ASCIITree
- For other visualization drivers, you first have Geant4 produce a file, and then you have that file rendered by another application (which may have GUI control)
 - HepRepFile
 - DAWNFILE
 - VRML2FILE
 - gMocrenFile
- You can open more than one driver at a time.
 - For example, do a quick check in OpenGL, then save the same event for a beautiful DAWN plot

Controlling Which Drivers are Available

- Six of the visualization drivers are always included by default (since they require no external libraries):
 - HepRepFile
 - DAWNFILE
 - VRMLFILE
 - RayTracer
 - gMocrenFile
 - ASCIITree
- Other visualization drivers are included only if appropriate environment variables have been set:
 - The standard Geant4 configure procedure takes care of these environment variables for you. It asks you which drivers you want and then produces a script, “env.sh” or “env.csh”, that you execute to set these variables.
- You can also add your own visualization driver.
 - Geant4’s visualization system is modular. By creating just three new classes, you can direct Geant4 information to your own visualization system.

Example Visualization Command Sequences

- Visualize a detector using the OpenGL visualization driver:
 - `/vis/open OGL`
 - `/vis/drawVolume`
- Visualize trajectories and hits for 10 events using the HepRep visualization driver:
 - `/vis/open HepRepFile`
 - `/vis/drawVolume`
 - `/vis/scene/add/trajectories`
 - `/vis/scene/add/hits`
 - `/run/beamOn 10`
- The step-by-step Geant4 Installation Tutorials tell you enough commands to get you started:
 - geant4.slac.stanford.edu/installation
- A more detailed discussion of commands can be found in:
 - geant4.slac.stanford.edu/Presentations/vis/G4VisCommands.pdf
 - geant4.slac.stanford.edu/Presentations/vis/G4VisAdvanced.pdf

Details on the Eight Visualization Drivers

- OpenGL
- OpenInventor
- HepRep
- DAWN
- VRML
- RayTracer
- gMocren
- ASCIITree

OpenGL

- /vis/open OGL
- Features
 - Control directly from Geant4
 - Uses GL libraries that are already included on most Linux and Windows systems
 - Rendered, photorealistic image with some interactive features
 - zoom, rotate, translate
 - Fast response (can usually exploit full potential of graphics hardware)
 - Save as pixel graphics or vector EPS
 - Live movies
- Supported by John Allison, Laurent Garnier and Guy Barrand

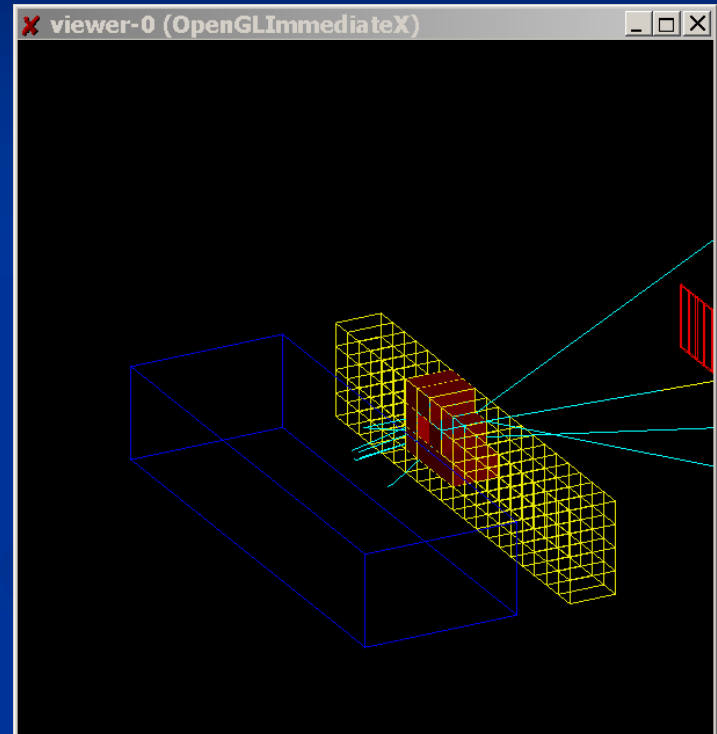

OpenGL with Qt Control

- New visualization driver and user interface
 - requires that you install Qt and link against this in your Geant4 ./Configure
 - you can customize the interface to control any Geant4 command

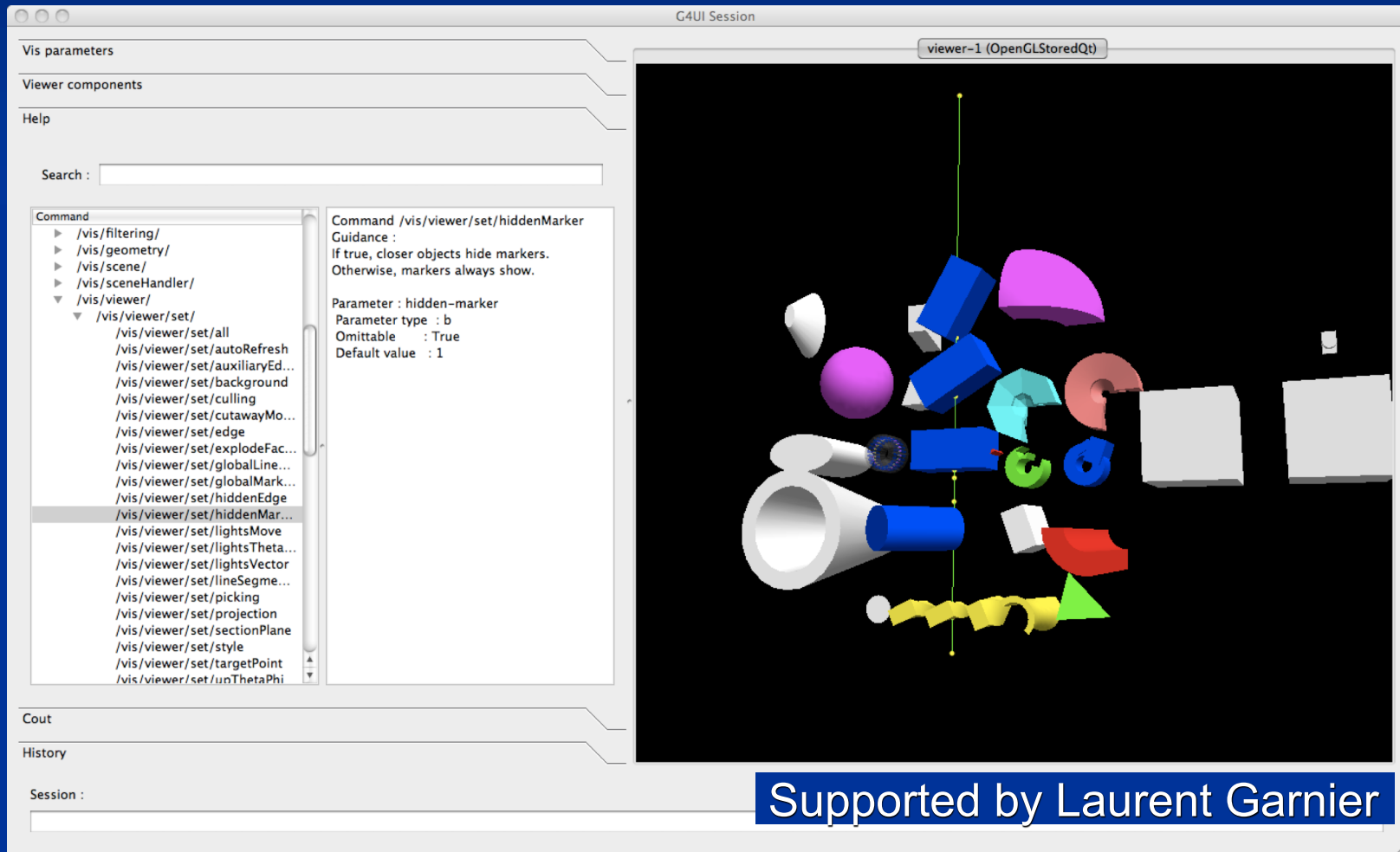

The screenshot displays the G4UI Session window, which is divided into several sections. On the left, there is a 'Vis parameters' panel with a search bar and a 'Command' list. The 'Command' list is expanded to show the path `/vis/viewer/set/hiddenMarker`. To the right of this list, the details for the selected command are shown: `Command /vis/viewer/set/hiddenMarker`, `Guidance : If true, closer objects hide markers. Otherwise, markers always show.`, `Parameter : hidden-marker`, `Parameter type : b`, `Omittable : True`, and `Default value : 1`. The main area of the window is a 3D viewer titled 'viewer-1 (OpenGLStoredQt)' showing a complex 3D visualization of a particle detector. The visualization includes various colored components such as a large white cylindrical structure, a blue cylindrical structure, a yellow helical structure, and several smaller colored blocks and spheres. The background is black, and the objects are rendered with shading and perspective.

Supported by Laurent Garnier

OpenGL with Motif Control

- Somewhat obsolete now that Qt can take over this functionality
 - but still supported
 - requires that you have Motif and link against this in your Geant4 ./Configure

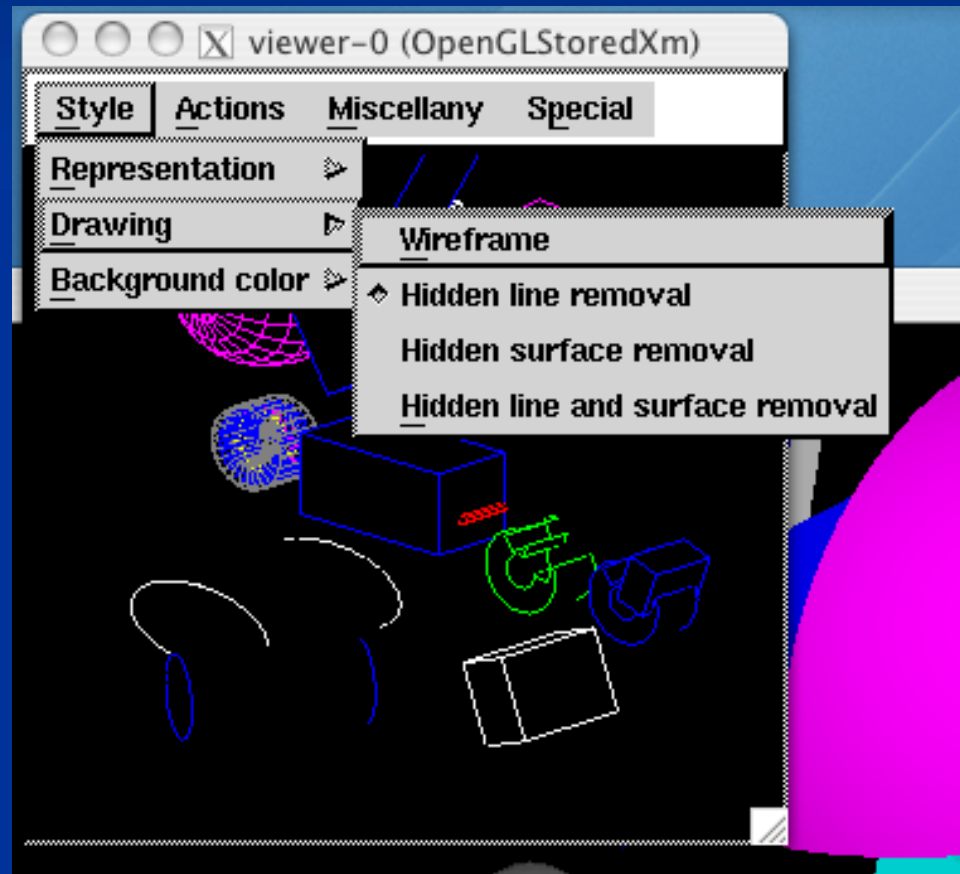
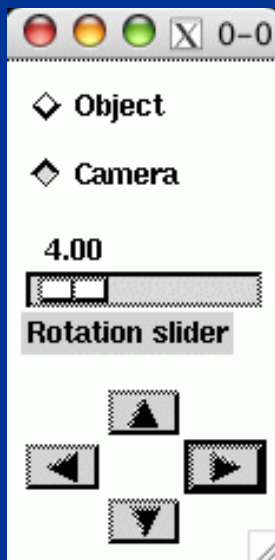

OpenGL Additional Modes

- There are actually two OpenGL modes, OGLS and OGLI
 - Stored mode: creates graphical database (display lists). Redrawing is faster because Geant4 only needs to resend parts that have changed. Nothing is lost on simple operations like change of viewing angle.
 - Immediate mode: draws only to screen, no “memory”; detector can be redrawn after view changes but event data is lost.
- And if you have Qt and Motif built and configured, even more options:
 - OGLSX, OGLIX, OGLSWin32 and OGLIWin32 are basic OpenGL (stored, immediate, stored for microsoft windows, immediate for microsoft windows)
 - OGLSQt and OGLIQt are OpenGL with Qt
 - OGLSXm and OGLIXm are OpenGL with Motif
- When you just use /vis/open OGL,
 - We provide you the most advanced OpenGL that you currently have configured - Qt if you have it, otherwise Motif, otherwise basic OpenGL
 - We give you Stored mode unless starts to use too much memory, in which case we switch to Immediate mode
 - We worry for you about whether you're on Windows or not
- To explicitly specify stored or immediate, but leave other decisions to us:
 - /vis/open OGLS
 - /vis/open OGLI

OpenGL Additional Notes

- OpenGL supports Smooth shading and Transparency
- OpenGL supports non-symmetric scaling:
 - `/vis/viewer/scale <3 vector of scale factors>`
 - or
 - `/vis/viewer/zoom <3 vector of scale factors>`

Hidden Line Removal

- OpenGL supports hidden line removal.
- You can control whether this removal is done and whether trajectories and hits are affected by this feature.
- By default, hidden line removal is disabled
- To turn on hidden line removal
 - `/vis/viewer/set/hiddenEdge 1`
- This hides edges of geometry, but lets trajectories through.
- To hide trajectories and hits as well
 - `/vis/viewer/set/hiddenMarker 1`

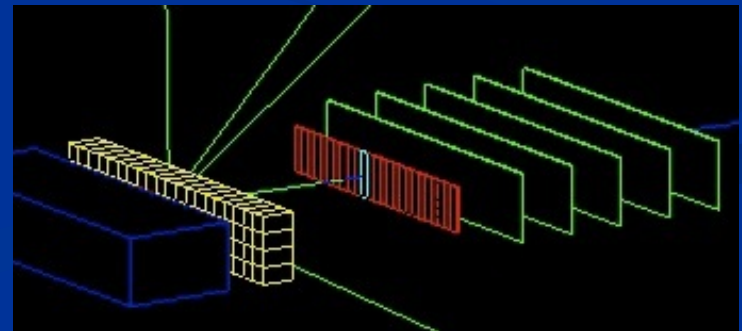
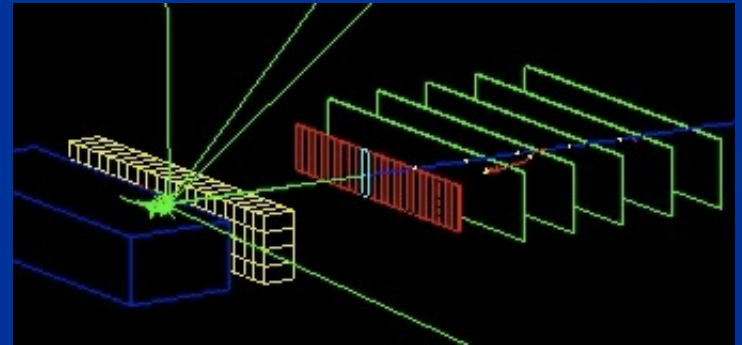
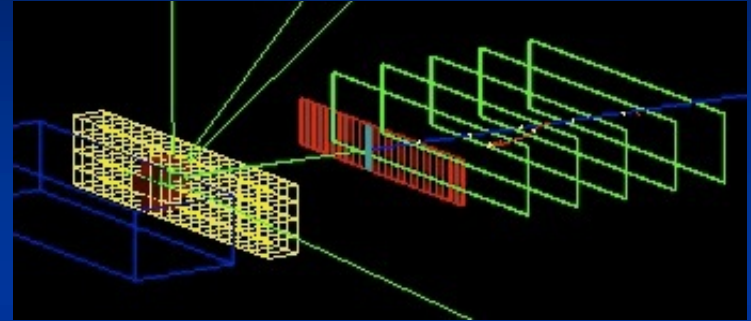

Postscript Printing

- OpenGL can save the current view to high quality Postscript files
 - `/vis/ogl/printEPS`
- Default output is Vectored, but can also produce Pixmap output
 - `/vis/ogl/set/printMode vectored or pixmap`
- Additional options:
 - `/vis/ogl/set/transparency True or False`

Movies: Time Development of the Event

- New features since release 8.2 allow you to do a new kind of Geant4 movie. You can make movies that show Time Development of an event
 - I.e., a shower in slow motion
- Based on technique of “time-slicing”, breaking trajectories into individual slices, each with a time attribute.
 - requires newer visualization features, rich trajectory and some extensions to the OpenGL driver
 - you can run these animations Directly from Geant4, does NOT involve stitching together a movie by hand
- A collection of example movies has been prepared by John Allison:
<http://www.hep.man.ac.uk/u/johna/pub/Geant4/Movies/>
- How-To Presentation:
<http://geant4.slac.stanford.edu/Presentations/vis/HowToMakeAMovie.ppt>
<http://geant4.slac.stanford.edu/Presentations/vis/HowToMakeAMovie.pdf>

50 MeV electron into
lead-liqAr calorimeter

e^- red
 e^+ blue
 γ green

Yellow circles are
step points --
geometrical
boundaries or
physical processes



Another 10 GeV π^-

3 fast π^-

π^+ interaction

3 ns

Mpeg4 encoding with
QuickTime Pro

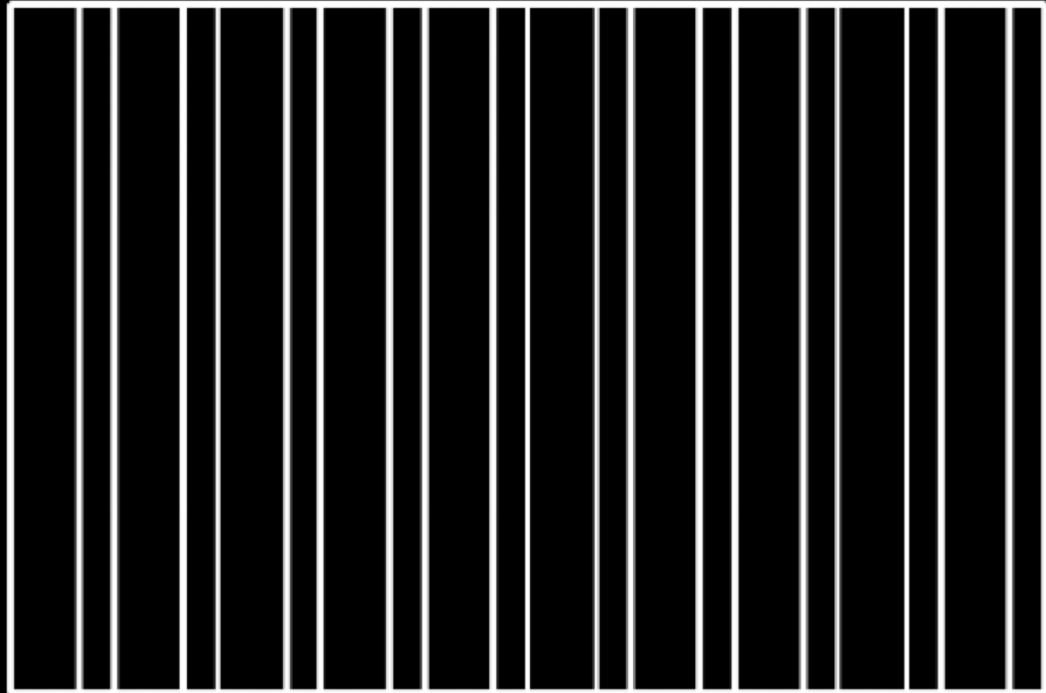

Movies: Live from Geant4 OpenGL



What was in the Previous Movie

- <http://www.hep.man.ac.uk/u/johna/pub/Geant4/Movies/pi-10Gevpi+neutronZoom.mp4>
- 10 GeV/c pi- on lead (in a lead-liquid-argon calorimeter, example N03 with QGSP physics)
 - A large number of slow pions, protons and neutrons
 - Three fast pi- and one fast pi+ that subsequently interacts again
 - Neutrons (yellow) hang around for several ns
- Green circle is the light front
 - Careful viewer will notice that near the end of the event, some particles appear to cross the light front. This was a bug in the way the light front sphere was rendered in perspective view, fixed in release 8.2

OpenInventor

- `/vis/open OIX` or `/vis/open IOWin32`
- Features
 - Control from the OpenInventor GUI
 - Requires addition of OpenInventor libraries (freely available for most Linux systems and Windows).
 - Rendered, photorealistic image
 - Many interactive features
 - zoom, rotate, translate
 - click to “see inside” opaque volumes
 - click to show attributes (momentum, etc., dumps to standard output)
 - Fast response (can usually exploit full potential of graphics hardware)
 - Expanded printing ability (vector and pixel graphics)
- Supported by Guy Barrand

OpenInventor: Start from Geant4

- With OpenInventor, start from Geant4, but then some control from OpenInventor GUI

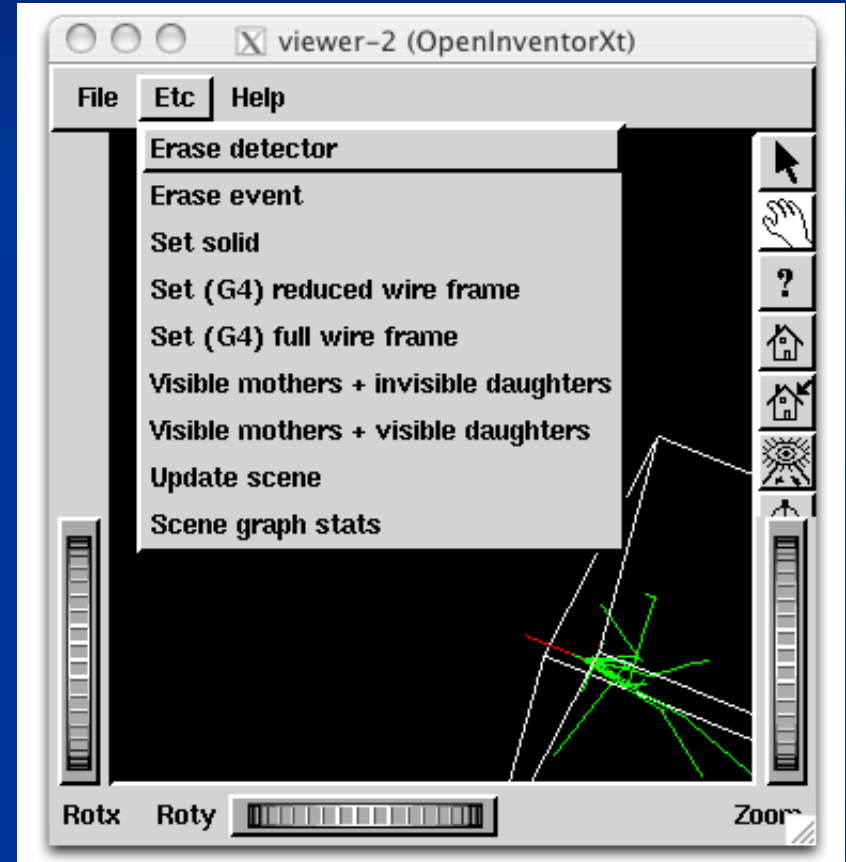
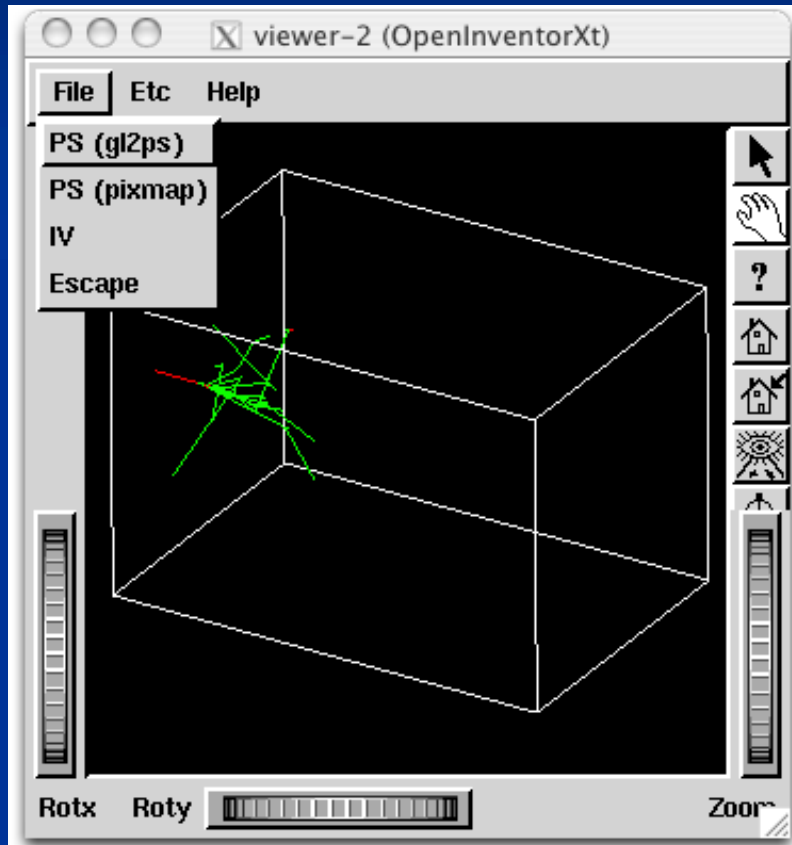

OpenInventor: More GUI Control

- You can also choose to control the Geant4 run from OpenInventor.

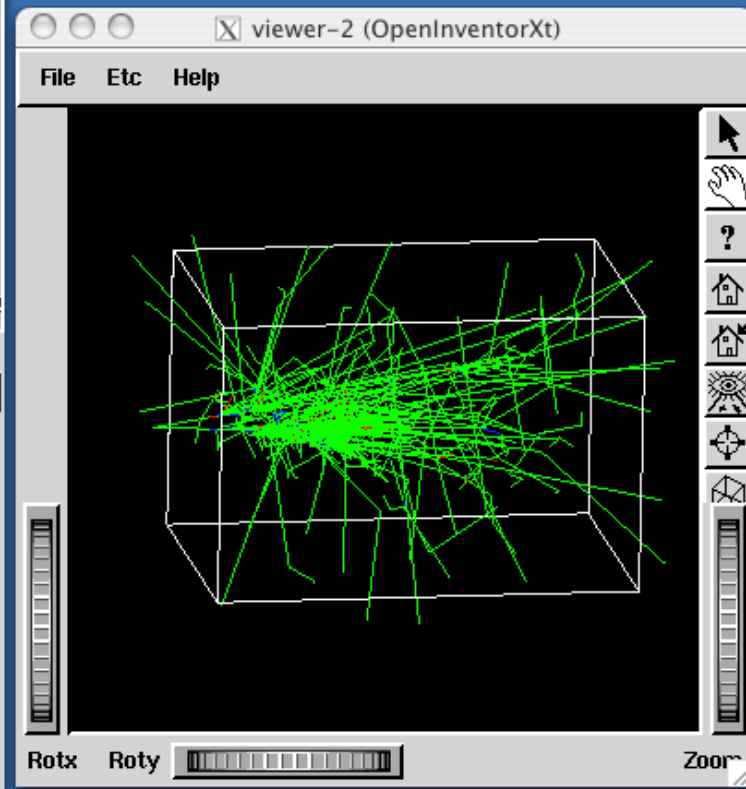
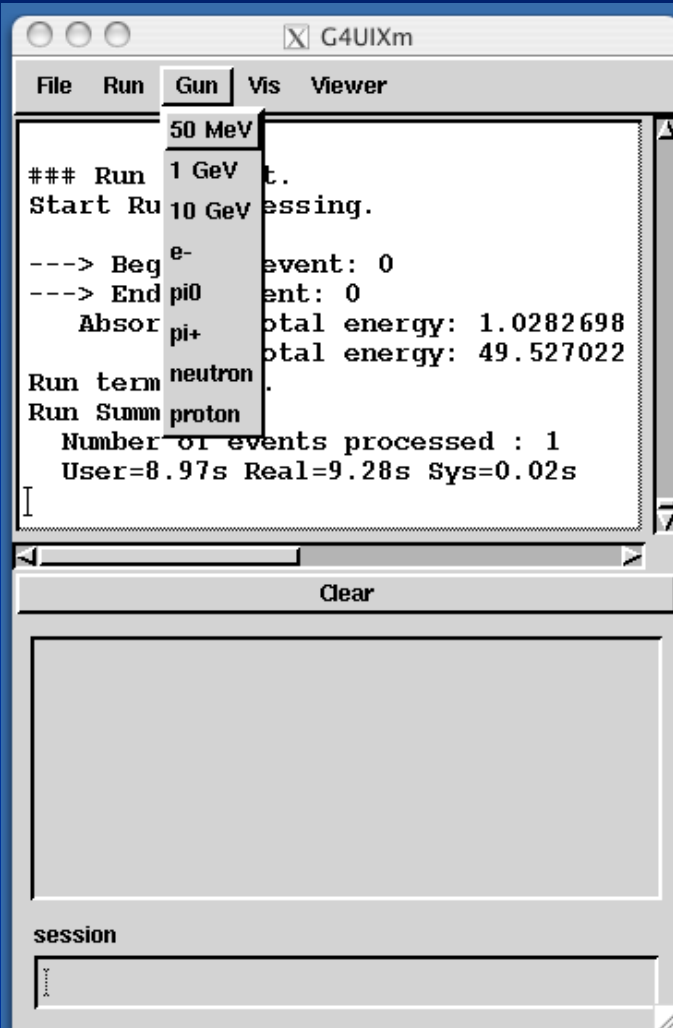

OpenInventor Details

- Connected directly to the Geant4 kernel, using same language as that kernel (C++):
 - Can have direct access to Geant4 data (geometry, trajectories, etc.).
- Use of OpenGL for rendering:
 - Supports lighting and transparency
- Thumbwheel control to rotate and zoom
- Picking to ask about data
- “Control Clicking” on a volume turns on rendering of that volume’s daughters. “Shift Clicking” a daughter turns that rendering off:
 - If modeling opaque solid, effect is like opening a box to look inside
- OpenInventor is an open source project
- OpenInventor is described on the OpenScientist Home Page <http://openscientist.lal.in2p3.fr>
 - Follow the “Geant4 and Inventor” link at the left hand side of that page for details.

HepRep

- /vis/open HepRepFile
- Features
 - Create a file to view in the
 - HepRApp HepRep Browser
 - WIRED4 JAS Plugin
 - or FRED Event Display
 - Requires one of the above browsers (freely available for all systems)
 - Wireframe or simple area fills (not photorealistic)
 - Many interactive features
 - zoom, rotate, translate
 - click to show attributes (momentum, etc.)
 - special projections (FishEye, etc.)
 - control visibility from hierarchical (tree) view of data
 - Hierarchical view of the geometry
 - HepRApp and WIRED4 can export to many vector graphic formats (PostScript, PDF, etc.)
- Supported by Joseph Perl

HepRep is Not Just for Geant4 and Not Just for HepRApp

BaBar Server

GLAST Gaudi
Service

Geant4
Server

HepRApp
HepRep
Browser (Java)

Wired4 Jas
Plug-In (Java)

FRED Client
(C++/Ruby)

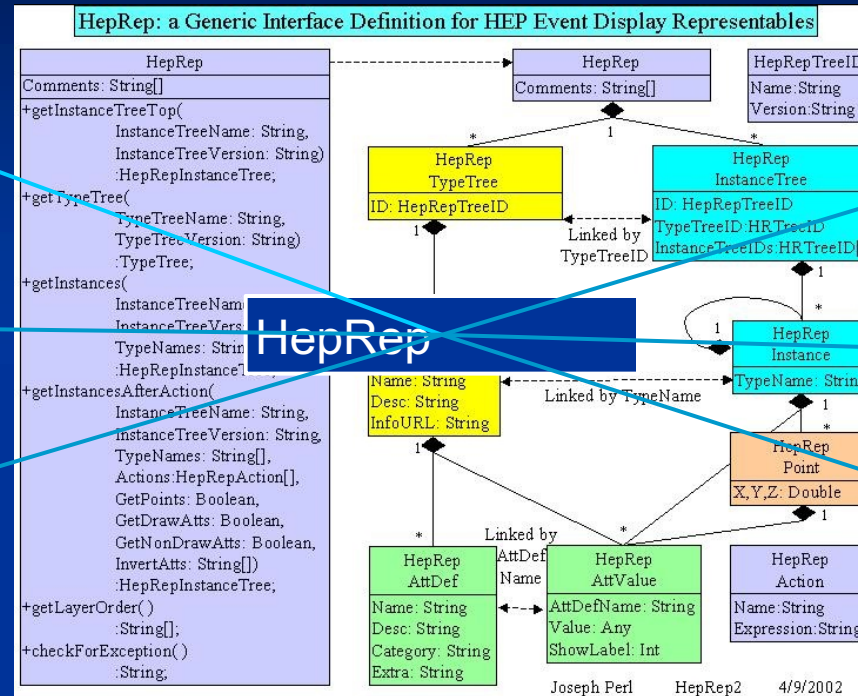

The HepRep interface breaks the dependency between any particular experiment's event display server and any particular event display client.

The HepRep format is independent of any one particular language or protocol. It can be used from C++ or Java and can be shipped as Corba, RMI, XML, C++, Java or JNI for consumption by HepRApp, Wired4, FRED or any other HepRep-enabled event display client.

Who's Using HepRep

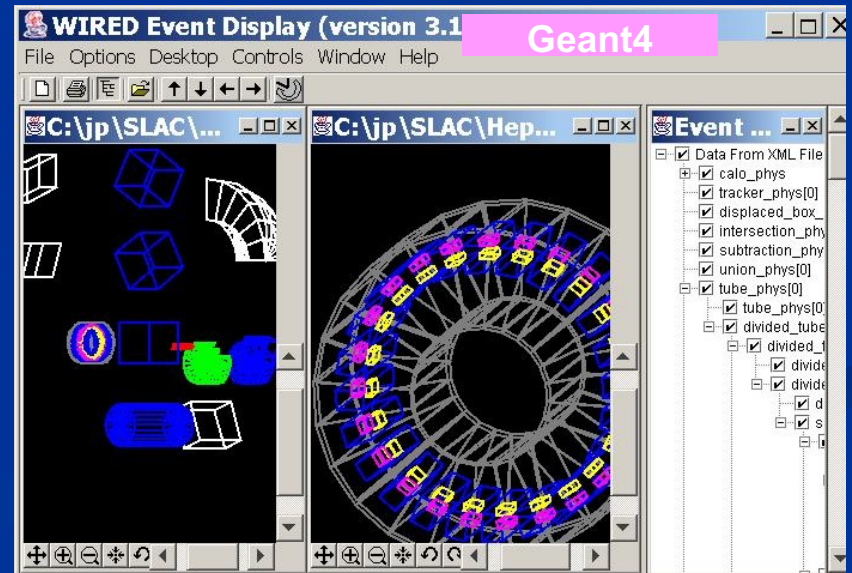
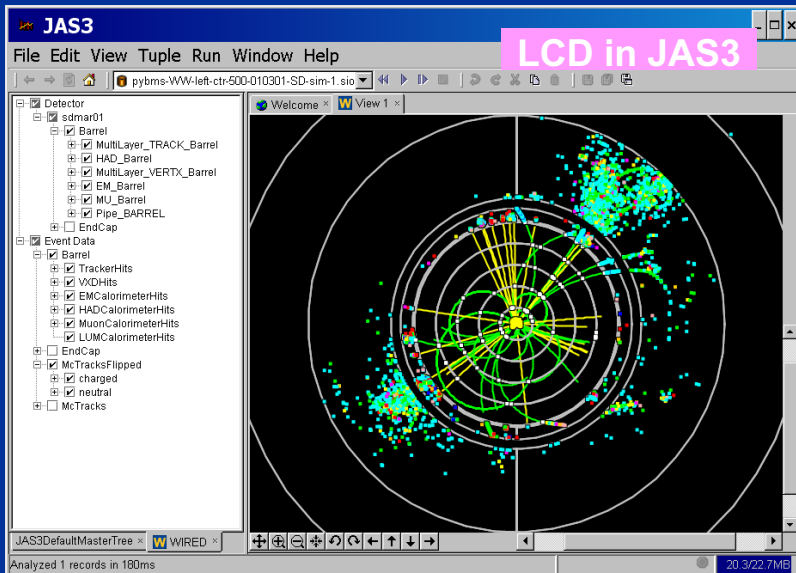
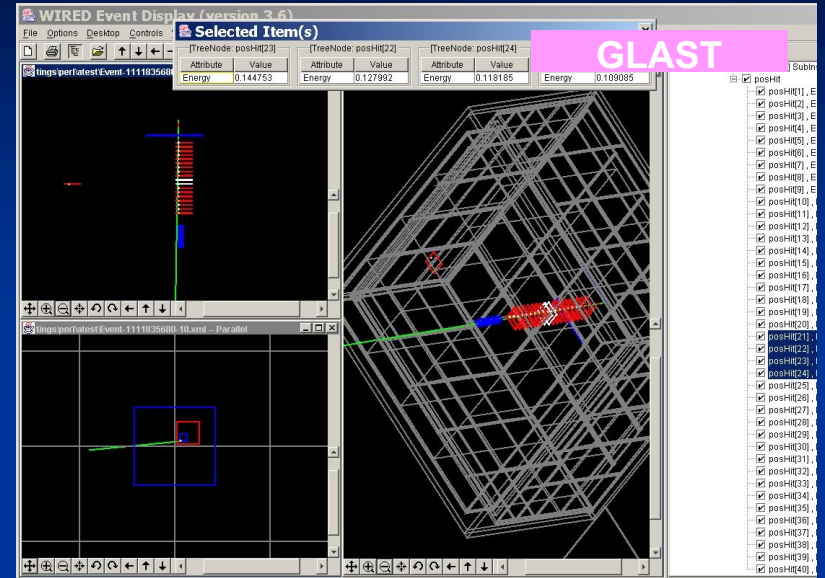
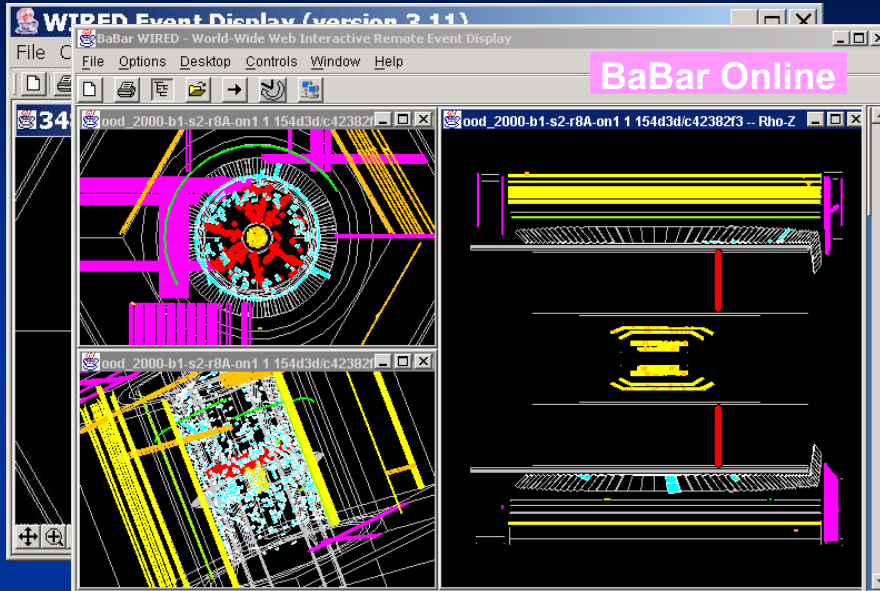

HepRApp: Shows Geometry Hierarchy

Turn visibility on and off from hierarchical control

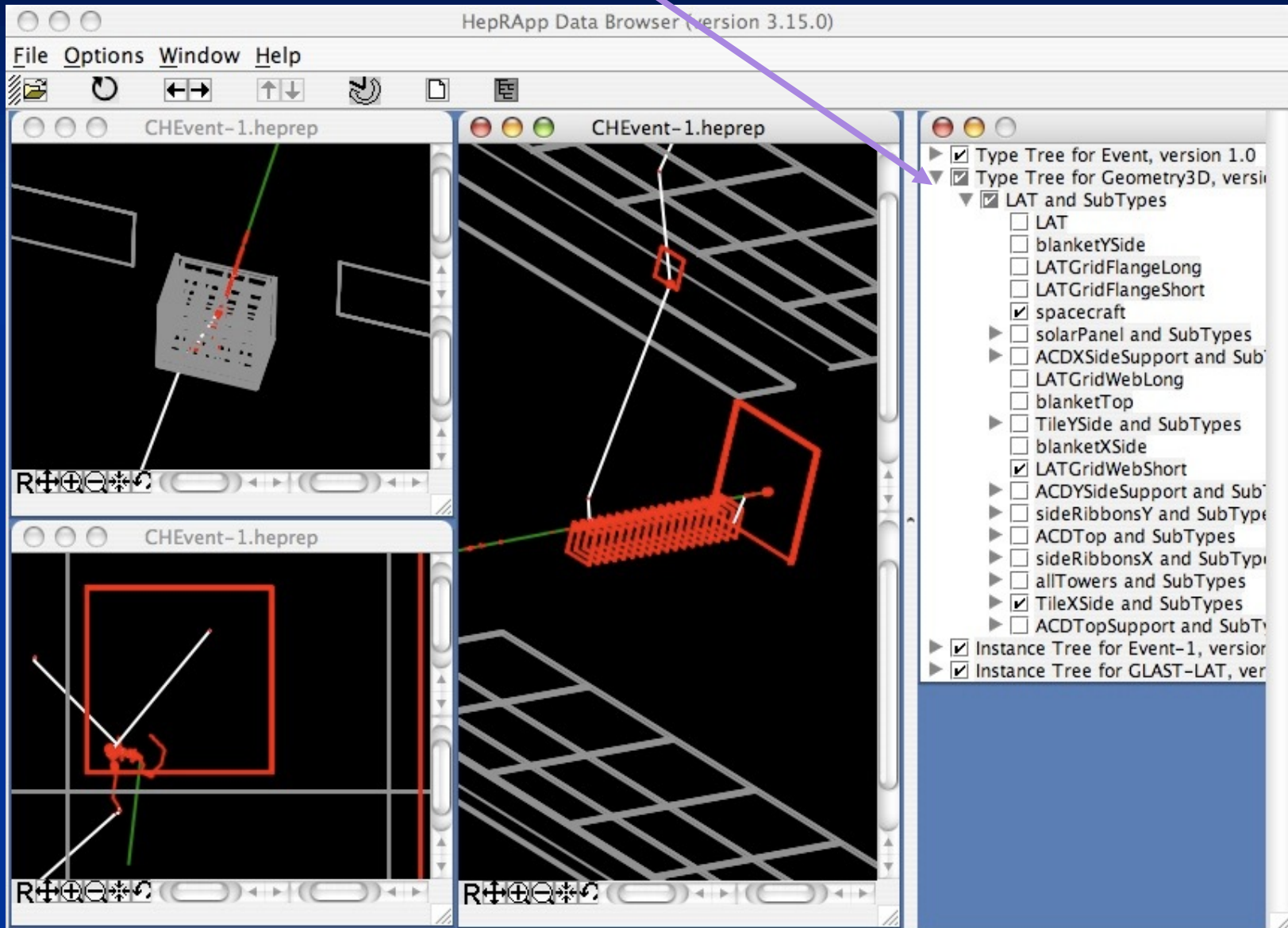

HepRApp: Pick to Show Physics Attributes

Picked on this volume to show

- Material
- Density
- Radlen
- etc

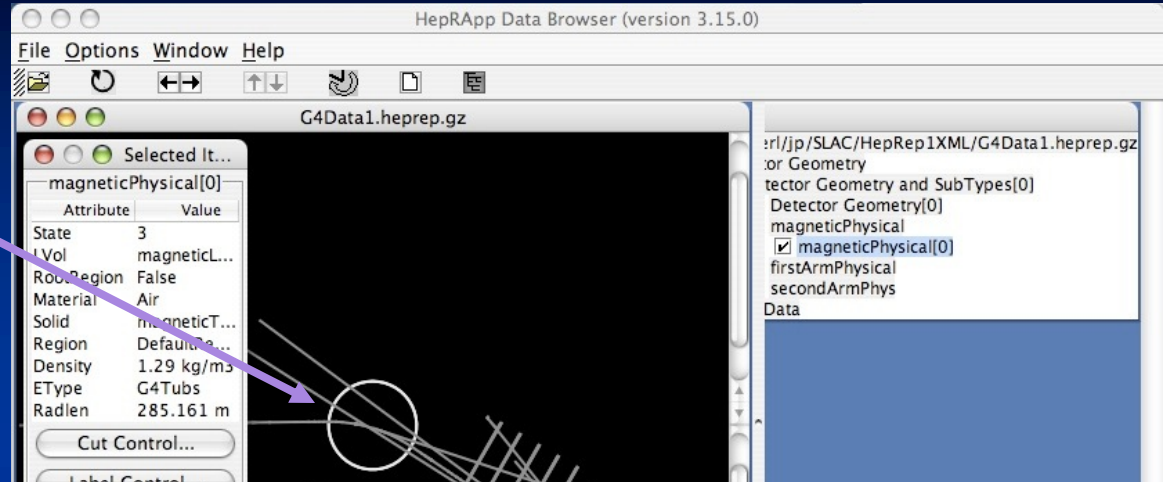

Picked on this trajectory to show

- Particle ID
- Charge
- Momentum
- etc.

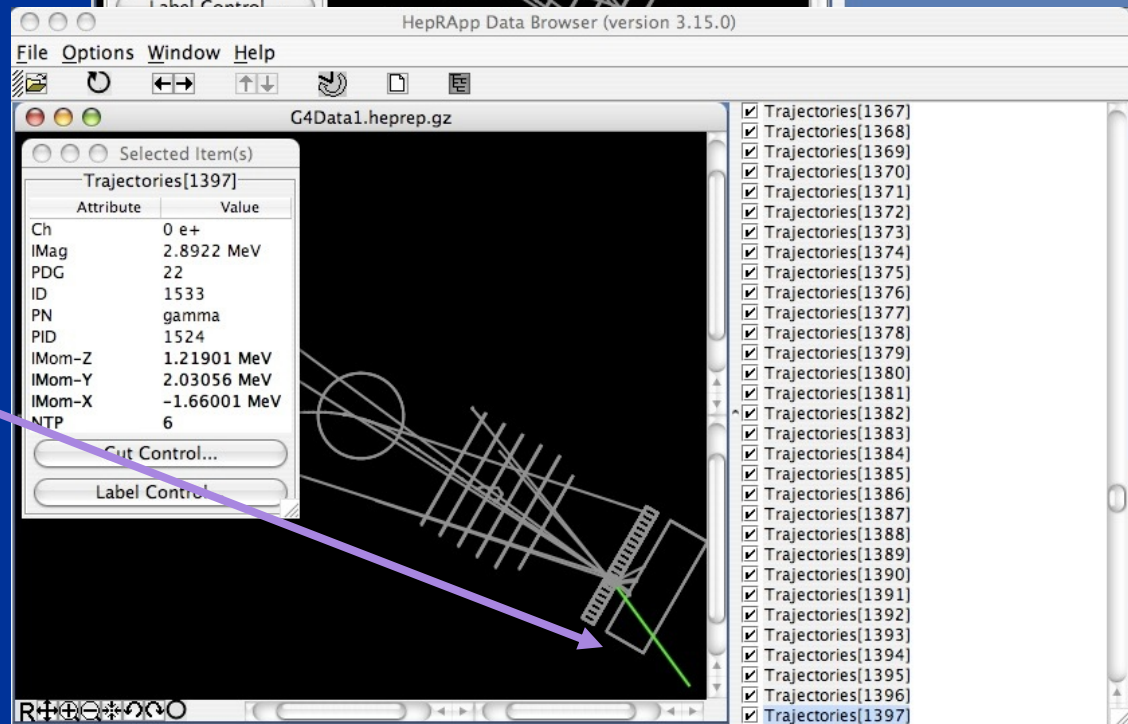

HepRApp: Labeling by Any Attribute

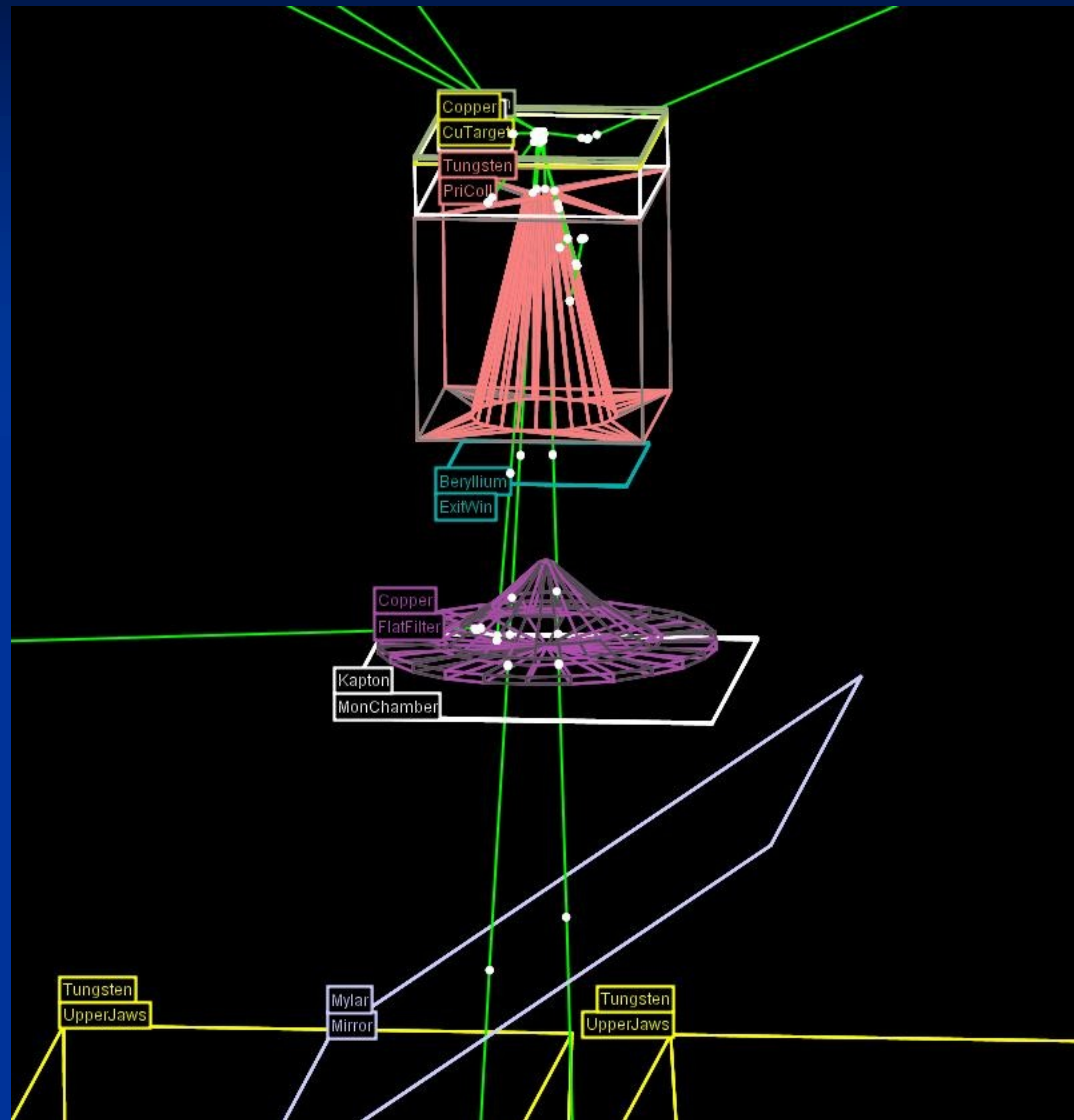

HepRApp: Cut by Any Attribute

The image displays a screenshot of the HepRApp Data Browser (version 3.15.0) interface. The main window, titled "G4Data1.heprep.gz", shows a visualization of particle trajectories. A blue trajectory enters from the left, passes through a series of vertical green bars, and then curves downwards. A white circle highlights the vertex where the trajectory changes direction. A label "Mag 993.317 MeV" is associated with the initial trajectory. The trajectory then passes through a series of vertical green bars and a red bar, and finally passes through a yellow detector-like structure. A label "Mag 122.683 MeV" is associated with the trajectory after the second set of green bars. The text "Trajectories: IMag>25.0" is visible at the bottom right of the visualization area. The interface includes a menu bar (File, Options, Window, Help), a toolbar with various icons, and a "HepRApp Cut Control" window. The Cut Control window has fields for "Generator" and "LVol", and options for "OR SET Min/Max" and "invert". A file browser on the right shows the path "/Users/perl/jp/SLAC/HepR".

WIRED4: Part of JAS

- Install JAS (Java Analysis Studio)
- Then download WIRED4 Plug-in
- <http://wired.freehep.org>

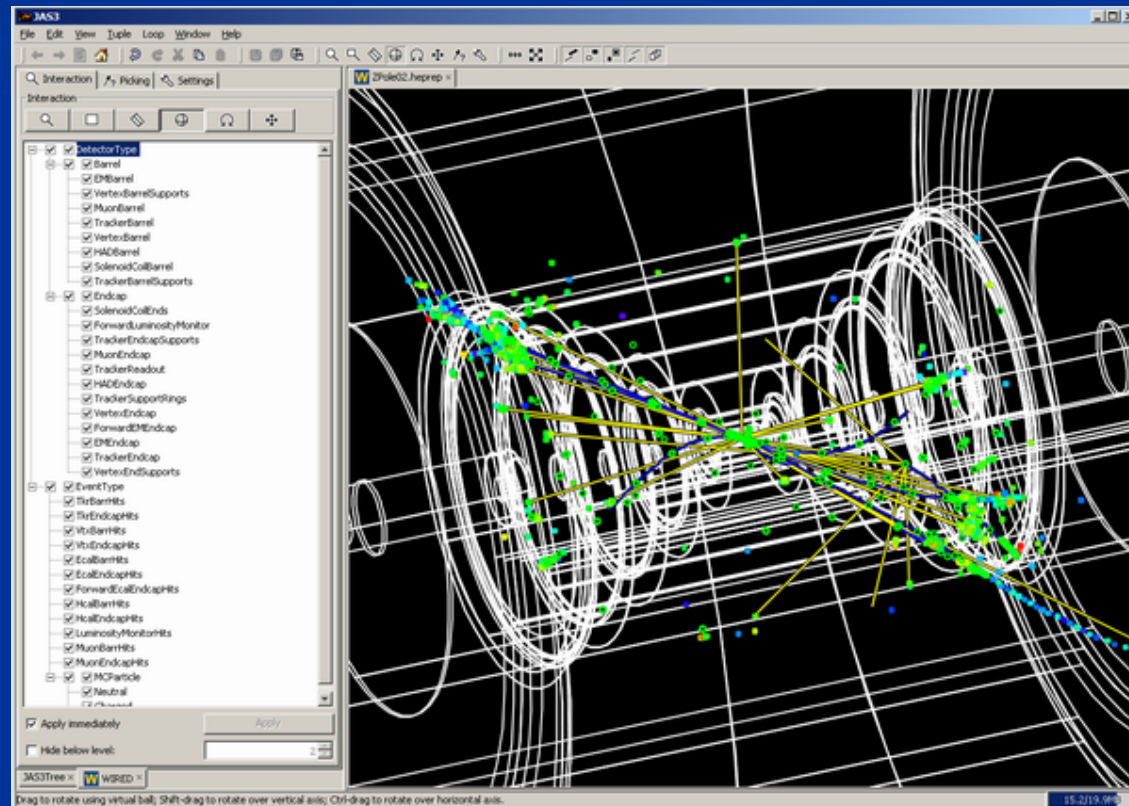

FRED: Fox Ruby Event Display

- An additional HepRep-compatible browser developed by members of the GLAST space telescope collaboration.
- Includes the fast rotations and beautiful rendering of GL plus HepRep interactivity
- Allows scripting to change any attribute based on logic involving other attributes, hence things like "color by momentum" are scriptable.

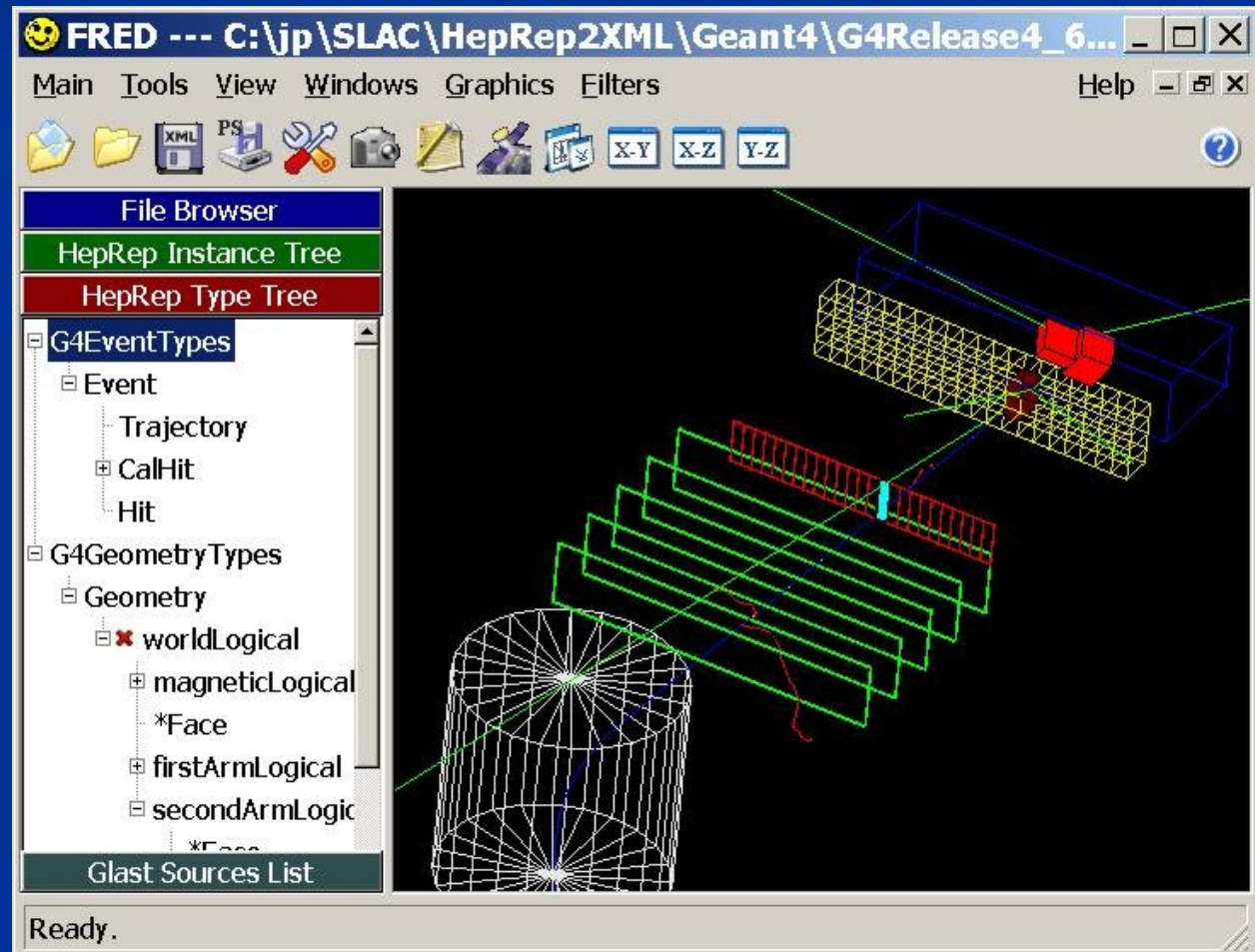

DAWN

- /vis/open DAWNFILE
- Features
 - Create a .prim file
 - Requires DAWN, available for all Linux and Windows systems
 - DAWN creates a rendered, photorealistic PostScript image
 - No interactive features once at PostScript stage
 - Highest quality technical rendering - vector PostScript
 - View or print from your favorite PostScript application
- Supported by Satoshi Tanaka

Origins of DAWN

Fukui Renderer DAWN (Drawer for Academic WritINgs).

- A vectorized 3D PostScript processor with analytical hidden line/surface removal intended for precise technical drawing of complicated objects.
- Specifically designed for Geant4.
- Primitives set is same as Geant4 primitives set.
- Produces device-independent vectorized graphics for high quality technical applications.

DAWN Examples

- From a repository of beautiful images at
 - http://geant4.kek.jp/~tanaka/GEANT4/ATLAS_G4_GIFFIG/

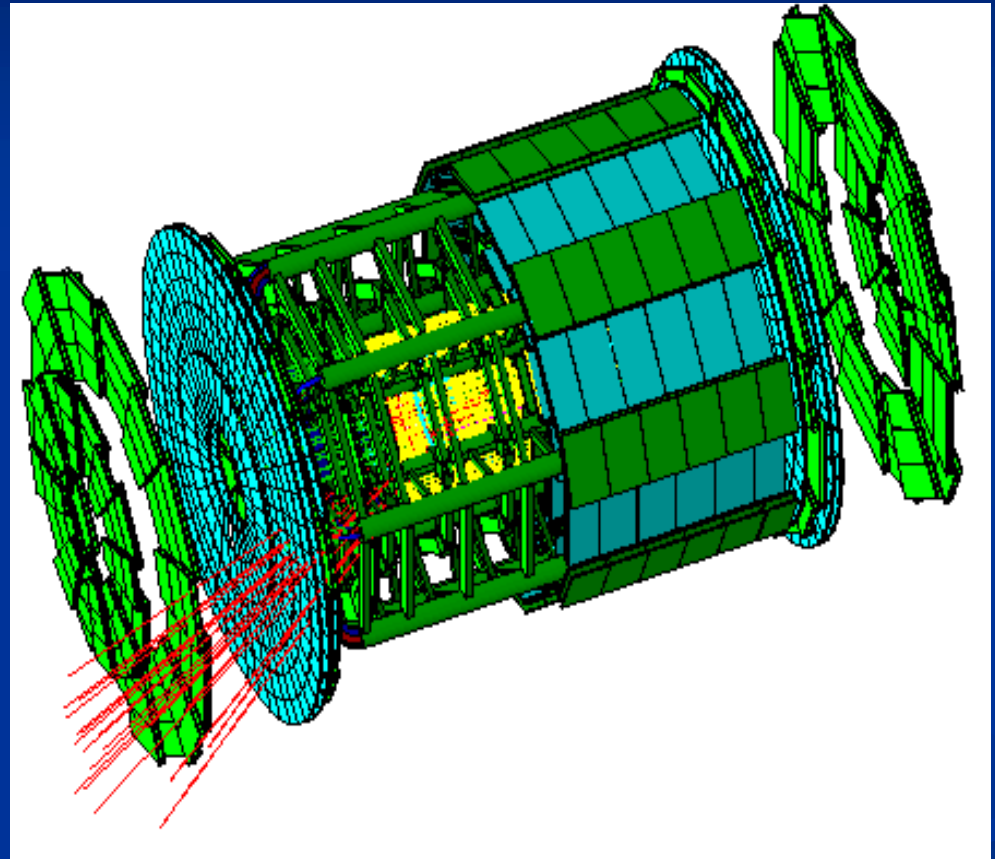
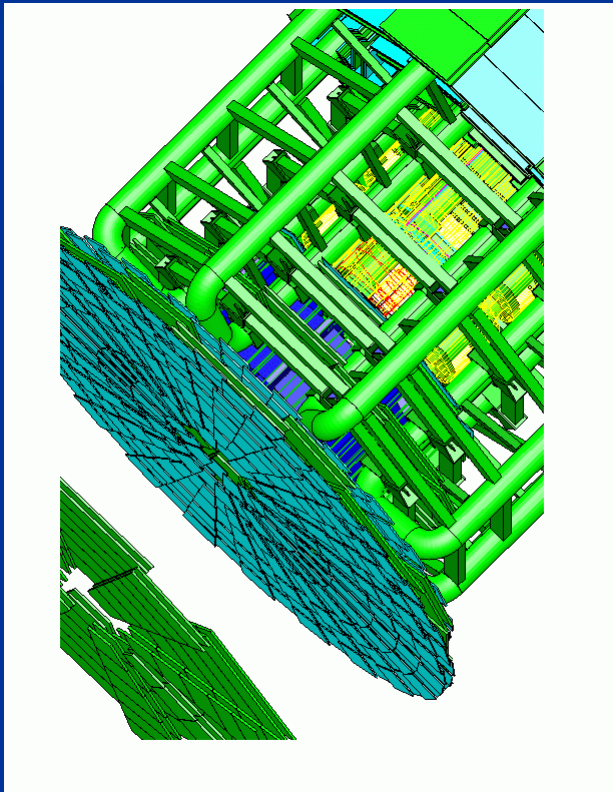

DAWN Examples

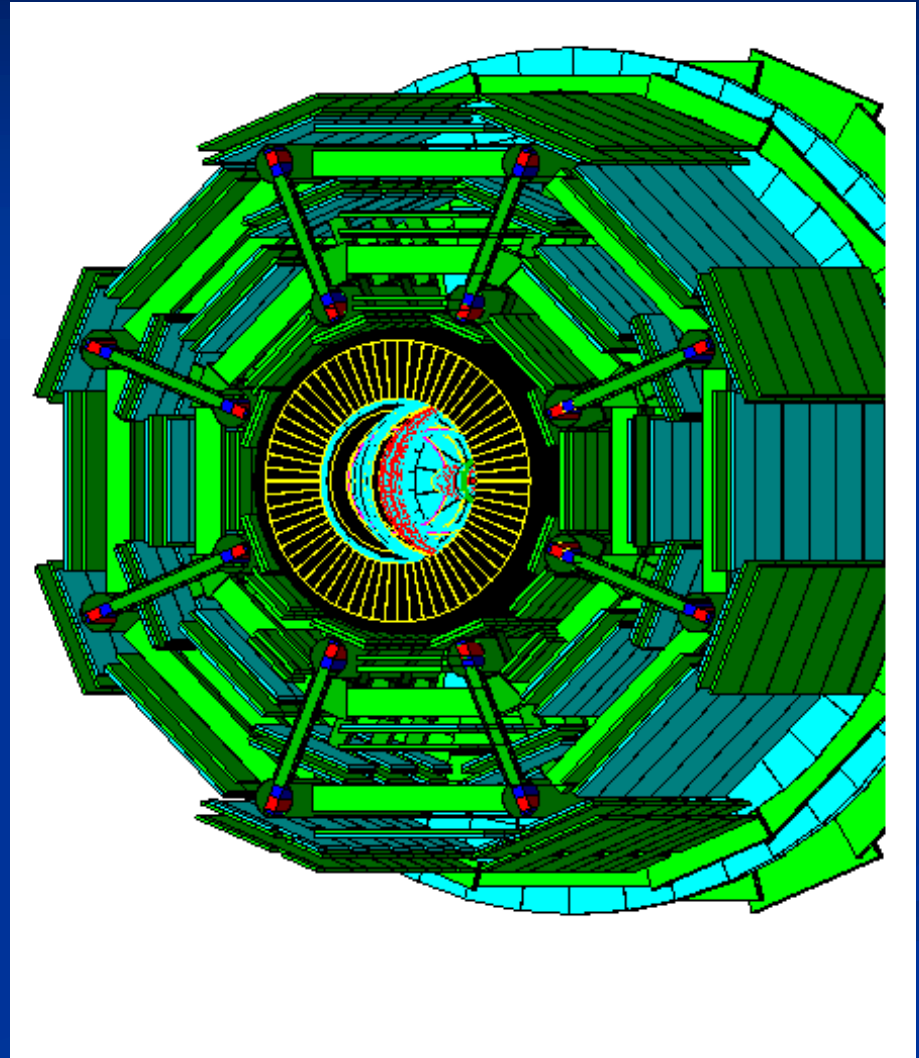
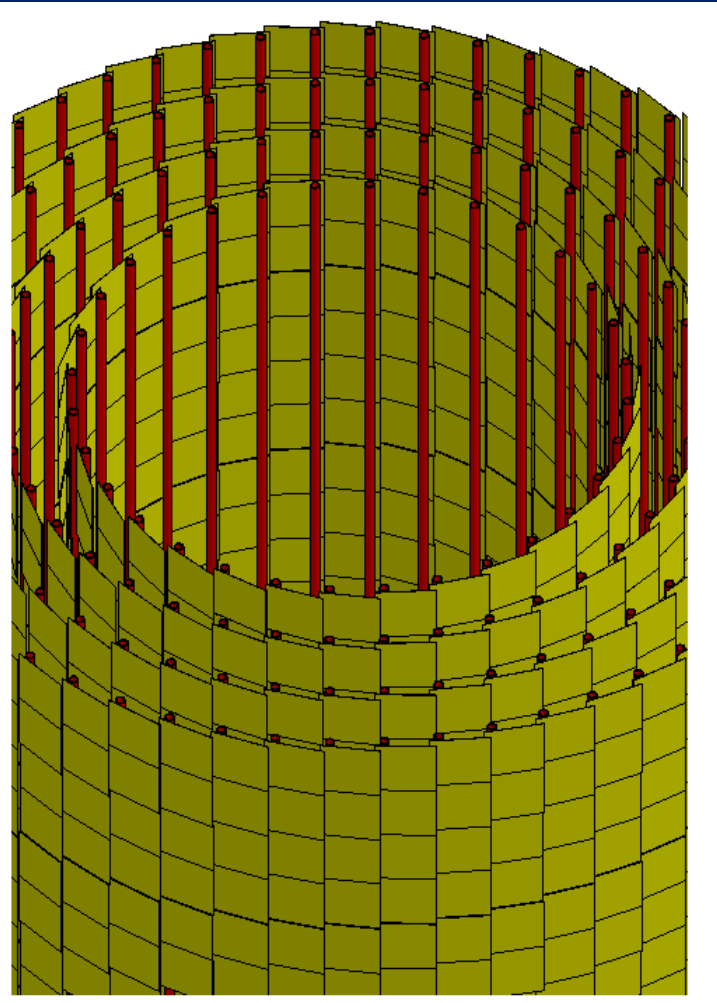

DAWN makes True Vector PostScript

- So when you zoom in with your PostScript browser, the images retain high resolution

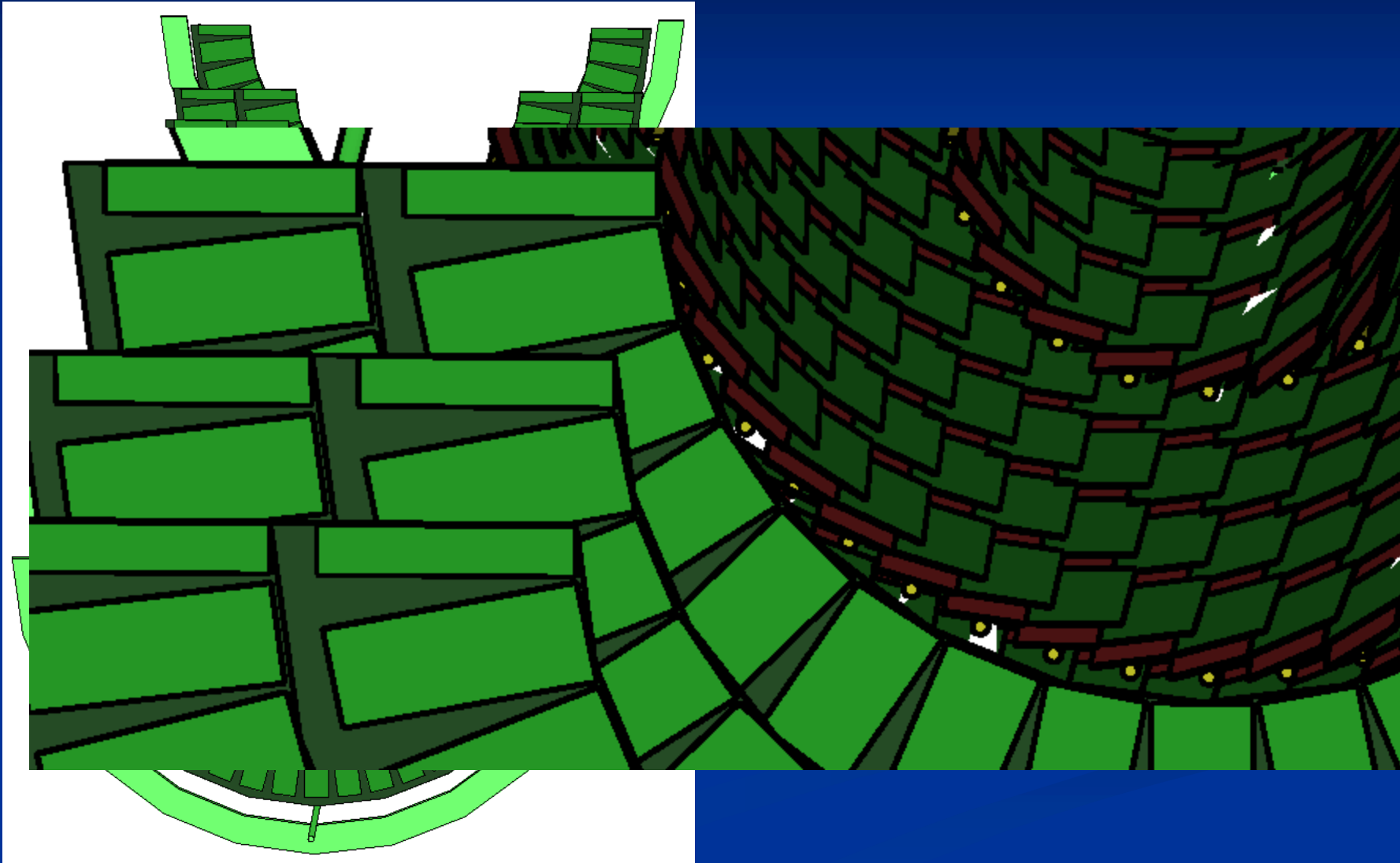

DAWN Additional Modes

- There are actually two DAWN drivers:
- `/vis/open DAWNFILE`
 - makes a `.prim` file suitable for viewing in the DAWN renderer
- `/vis/open DAWN`
 - establishes a direct connection between Geant4 and the DAWN renderer
 - The DAWN renderer must be linked in at the time that you link Geant4 itself
 - See details in the Application Guide

DAWNCUT and DAVID

- A standalone program, DAWNCUT, can perform a planar cut on a DAWN image.
 - DAWNCUT takes as input a .prim file and some cut parameters. Its output is a new .prim file to which the cut has been applied.
- Another standalone program, DAVID, can show you any volume overlap errors in your geometry.
 - DAVID takes as input a .prim file and outputs a new .prim file in which overlapping volumes have been highlighted.
- Details at <http://geant4.kek.jp/~tanaka/>

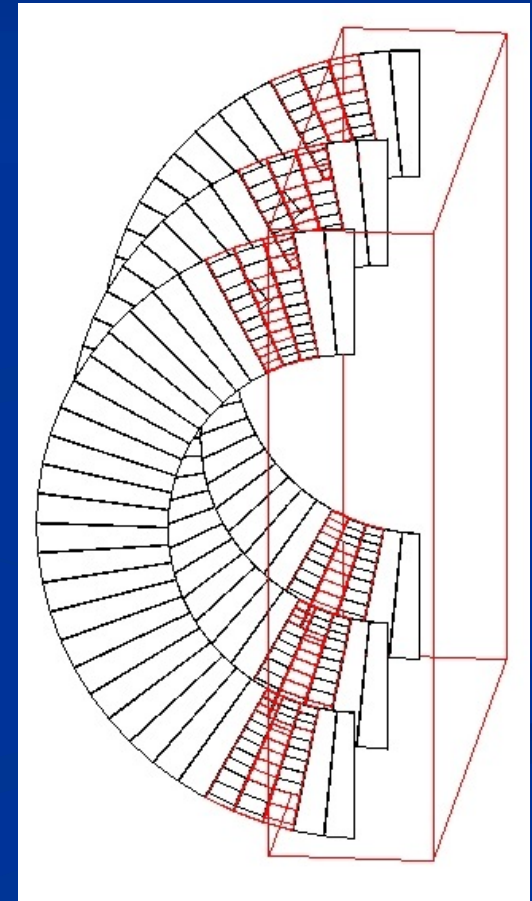

HepRep and DAWN work through Files

- With HepRep and DAWN, Geant4 creates a file:

Example .heprep File

```
<heprep
xmlns:xsi="http://www.w3.org/2001/XMLSchema-instance"
  xsi:schemaLocation="HepRep.xsd">
<layerorder="Detector, Event, CalHit, Trajectory, TrajectoryPoint, Hit"/>
<typetree name="G4GeometryTypes" version="1.0">
  <type name="Detector">
    <attvalue name="Layer" showLabel="NONE" type="String" value="Detector"/>
    <attdef category="Physics" desc="Logical Volume" extra="" name="LVol"/>
    <attdef category="Physics" desc="Material Name" extra="" name="Material"/>
    <type name="Detector/World">
      <type name="Detector/World/Calorimeter">
        <type name="Detector/World/Calorimeter/Layer">
          <type name="Detector/World/Calorimeter/Layer/Lead">
            </type>
          </type>
        </type>
      </type>
    </type>
  </typetree>
<typetree name="G4EventTypes" version="1.0">
  <type name="Event">
    <attvalue name="Layer" showLabel="NONE" type="String" value="Event"/>
    <type name="Event/Trajectory">
```

Example .prim File

```
##G4.PRIM-FORMAT-2.4

##### List of primitives 1 #####
/BoundingBox -1.0 -1.0 -5.0 8.0 4.0 6.0
!SetCamera
!OpenDevice
!BeginModeling

# Box
/Origin 0.0 0.0 0.0
/ColorRGB 1.0 0.0 0.0
/Box 0.5 2.0 4.5

# Column
/Origin 4.0 0.0 0.0
/ColorRGB 0.0 1.0 0.0
/Ndiv 50
/Column 1.5 2.0

# Trd
/Origin 0.0 0.0 0.0
/ColorRGB 0.0 1.0 1.0
/Origin 7.0 0.0 0.0
/Trd 1 0.5 1 0.5 4

# Cone segment
/Origin 1.0 5.0 0.0
/ColorRGB 0.0 1.0 1.0
```

HepRep and DAWN work through Files

- And you then run an application to visualize that file:

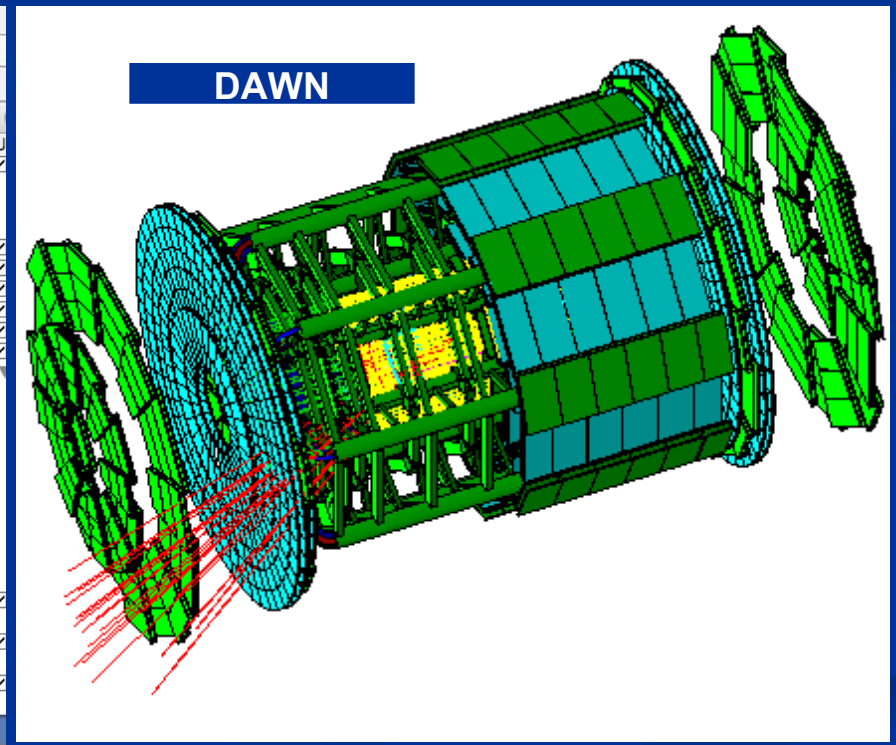
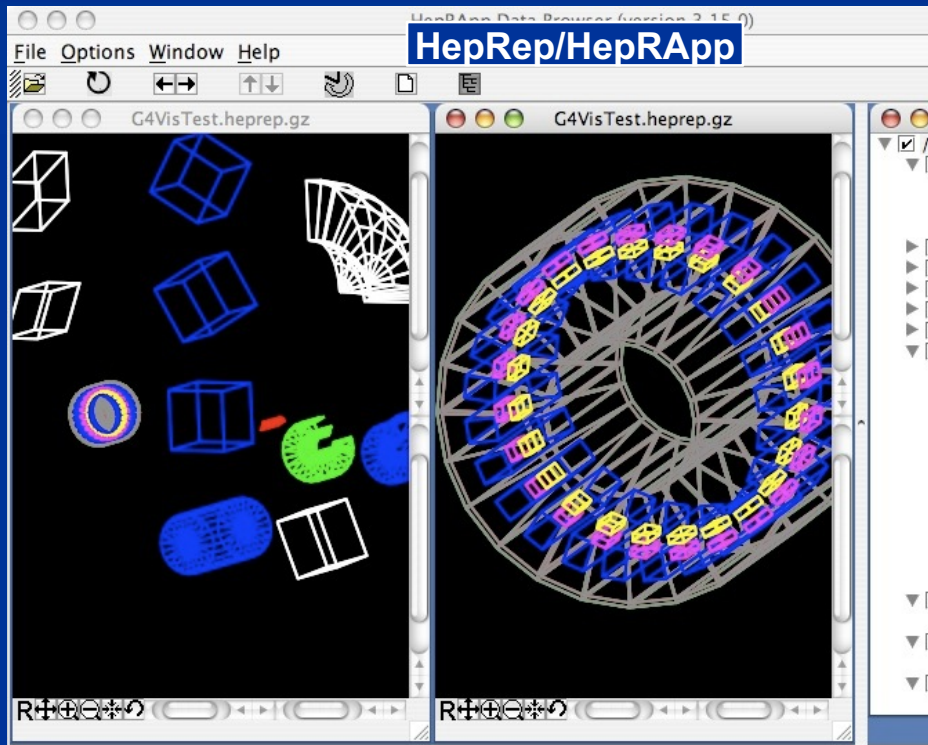

HepRep and DAWN: complimentary file formats, each with its own strengths

HepRep

- Hierarchical
- Simple Primitives
- General Purpose
- Representables have Attributes
- No Camera or Lighting Information

DAWN

- Flat
- All Geant4 Primitives
- Just for Geant4
- No Attributes
- Camera and Lighting Information

VRML

- `/vis/open VRML1FILE` or `/vis/open VRML2FILE`
- Features
 - Create a file to view in any VRML browser (some as web browser plug-ins).
 - Requires VRML browser (many different choices for different operating systems).
 - Rendered, photorealistic image with some interactive features
 - zoom, rotate, translate
 - Limited printing ability (pixel graphics, not vector graphics)
- Supported by Satoshi Tanaka

VRML

- Geant4 creates VRML File
 - /vis/open VRML1FILE or /vis/open VRML2FILE
- View file in a VRML Browser
 - Many free options, for example, here is one from octaga.com

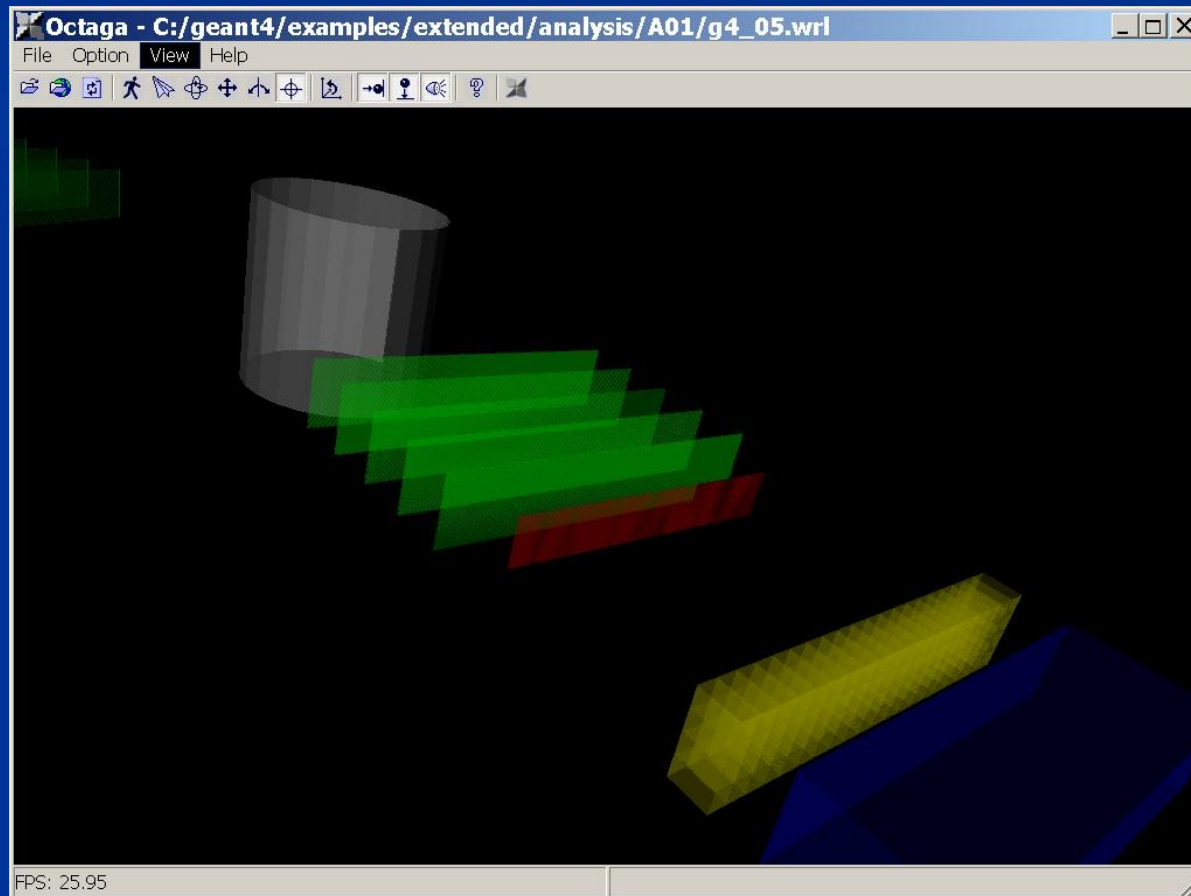

VRML Additional Modes

- There are actually 4 VRML drivers:
 - VRML1FILE
 - makes a file of VRML version 1
 - VRML2FILE
 - makes a file of VRML version 2
 - VRML1
 - establishes a direction connection between Geant4 and your VRML1 renderer
 - the VRML1 renderer must be linked in at the time that you link your Geant4 application
 - VRML2
 - establishes a direction connection between Geant4 and your VRML2 renderer
 - the VRML2 renderer must be linked in at the time that you link your Geant4 application
 - See details in the Application Developer's Guide

RayTracer

- /vis/open RayTracer
- Features
 - Create a jpeg file
(and with RayTracerX option, also draws to x window)
 - Forms image by using Geant4's own tracking to follow photons through the detector
 - Can show geometry but not trajectories
 - Can render any geometry that Geant4 can handle (such as Boolean solids) - no other Vis driver can handle every case
 - Supports shadows, transparency and mirrored surfaces
- Supported by Makoto Asai and John Allison

RayTracer

- RayTracer works by using Geant4's own tracking to shoot photons through the detector onto a sensitive plane. The resulting image is presented as a jpeg file.
 - /vis/open RayTracer
- Some pieces of geometries may fail to show up in other visualization drivers (due to algorithms those drivers use to compute visualizable shapes and polygons), but RayTracer can handle any geometry that the Geant4 navigator can handle.
- RayTracer can not be used to visualize Trajectories.
- Commands:
 - 1) trace * Start the ray tracing.
 - 2) column * Define the number of horizontal pixels.
 - 3) row * Define the number of vertical pixels.
 - 4) target * Define the center position of the target.
 - 5) eyePosition * Define the eye position.
 - 6) lightDirection * Define the direction of illumination light.
 - 7) span * Define the angle per 100 pixels.
 - 8) headAngle * Define the head direction.
 - 9) attenuation * Define the attenuation length for transparent material.
 - 10) distortion * Distortion effect of the fish eye lens.
 - 11) ignoreTransparency * Ignore transparency even if the alpha of G4Colour < 1
 - 12) backgroundColour * Set background colour: red green blue: range 0.->1.

RayTracer Shows Shadows

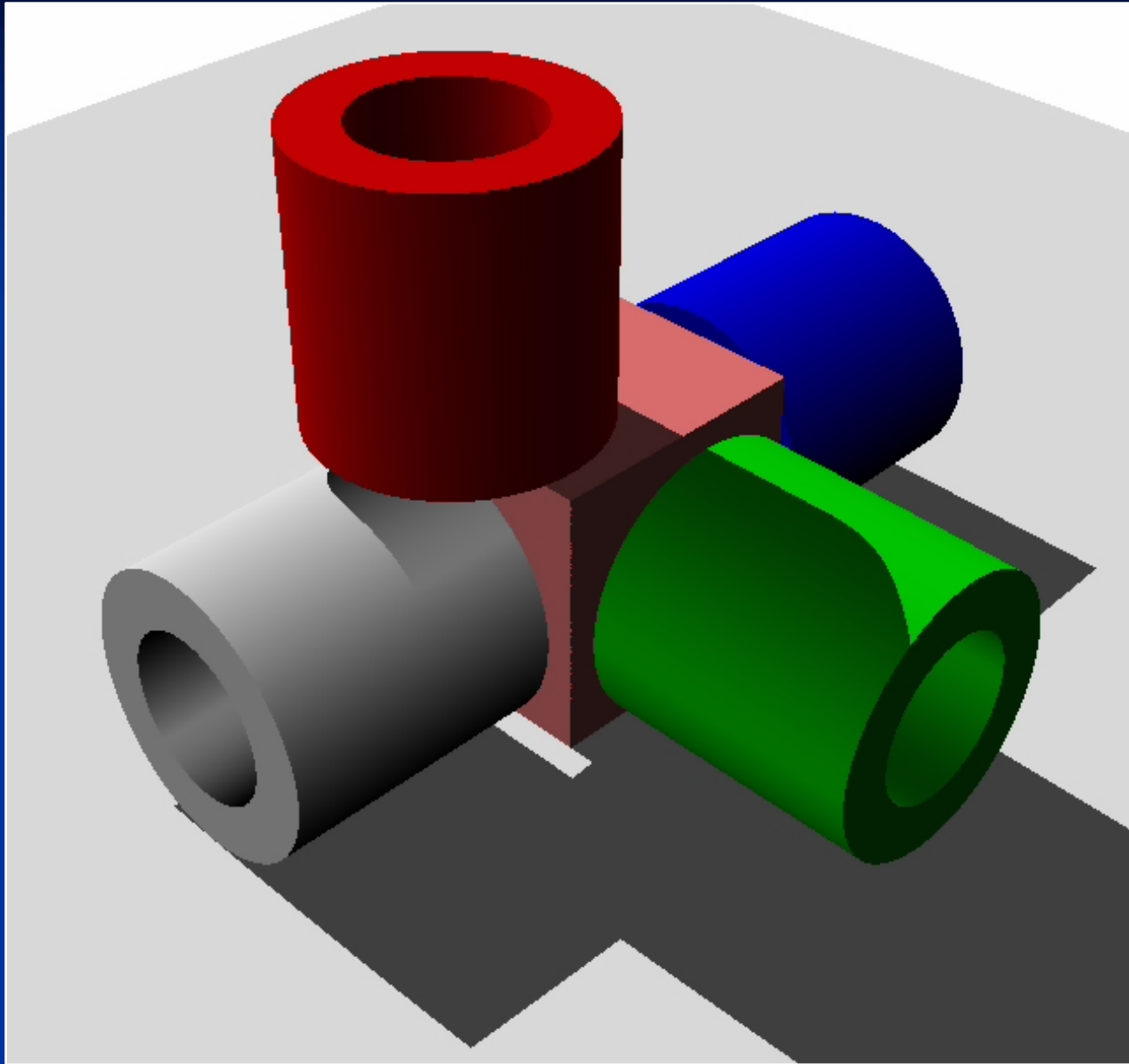

RayTracer Supports Transparency

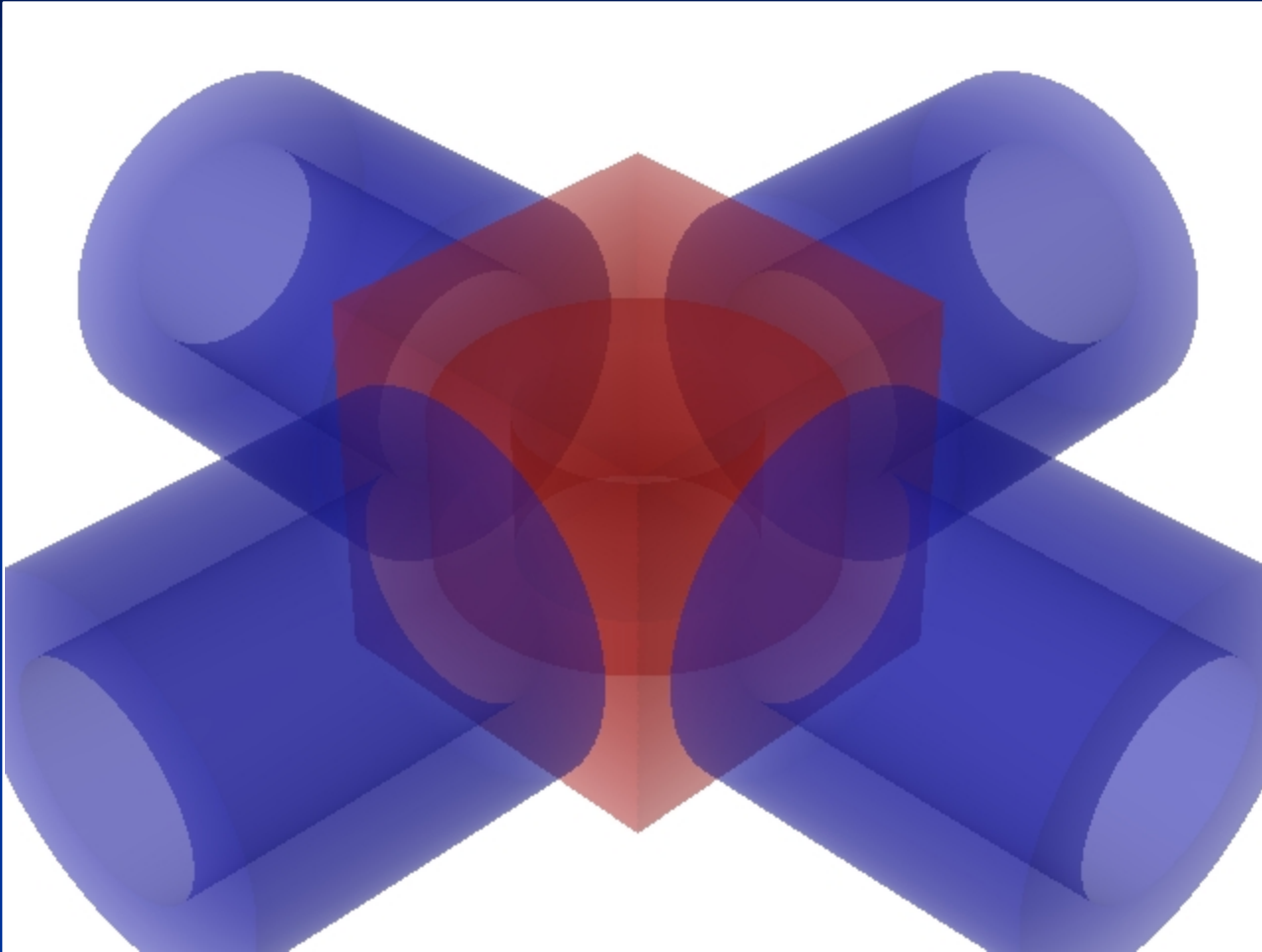

RayTracer Handles Mirrored Surfaces

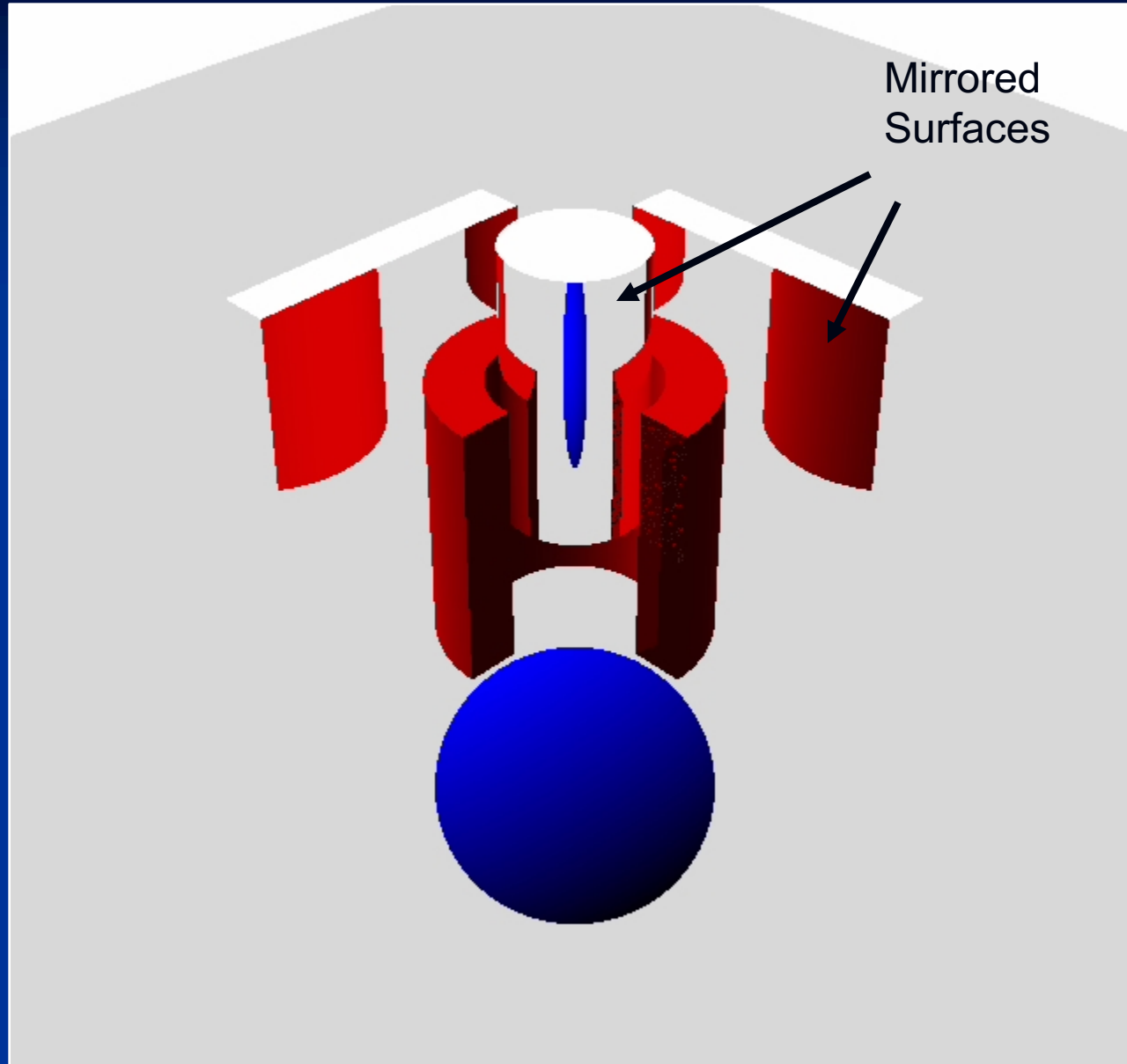

RayTracer Handles Boolean Solids

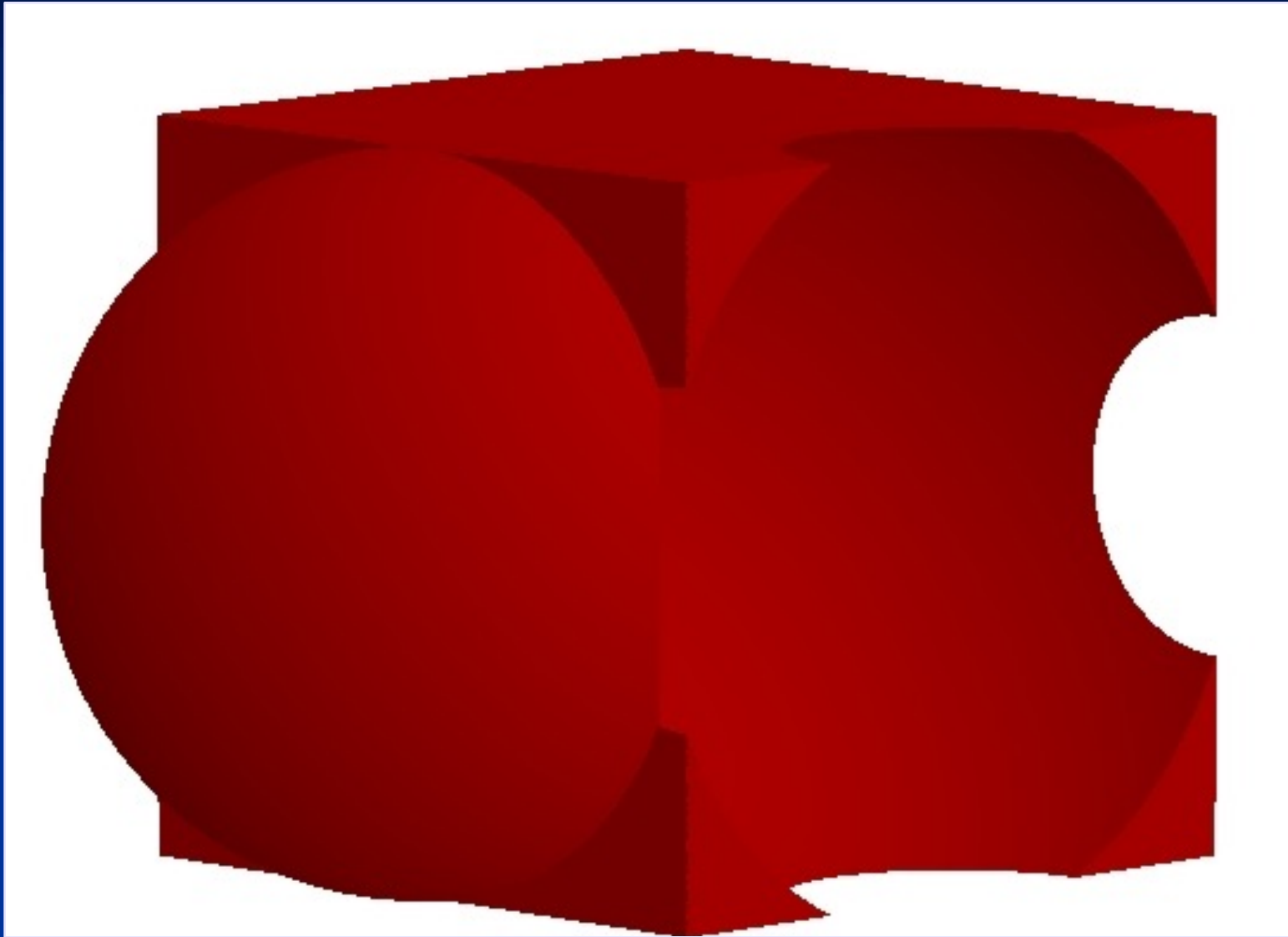

RayTracerX

- New since Geant4.8.0
- In addition to
 - `/vis/open RayTracer`
- You have the option of
 - `/vis/open RayTracerX`
- Builds same jpeg file as RayTracer, but simultaneously renders to screen so you can watch as rendering grows progressively smoother.
- Means you can abort and retry the rendering with different view parameters without having to wait for the complete refinement of the image.

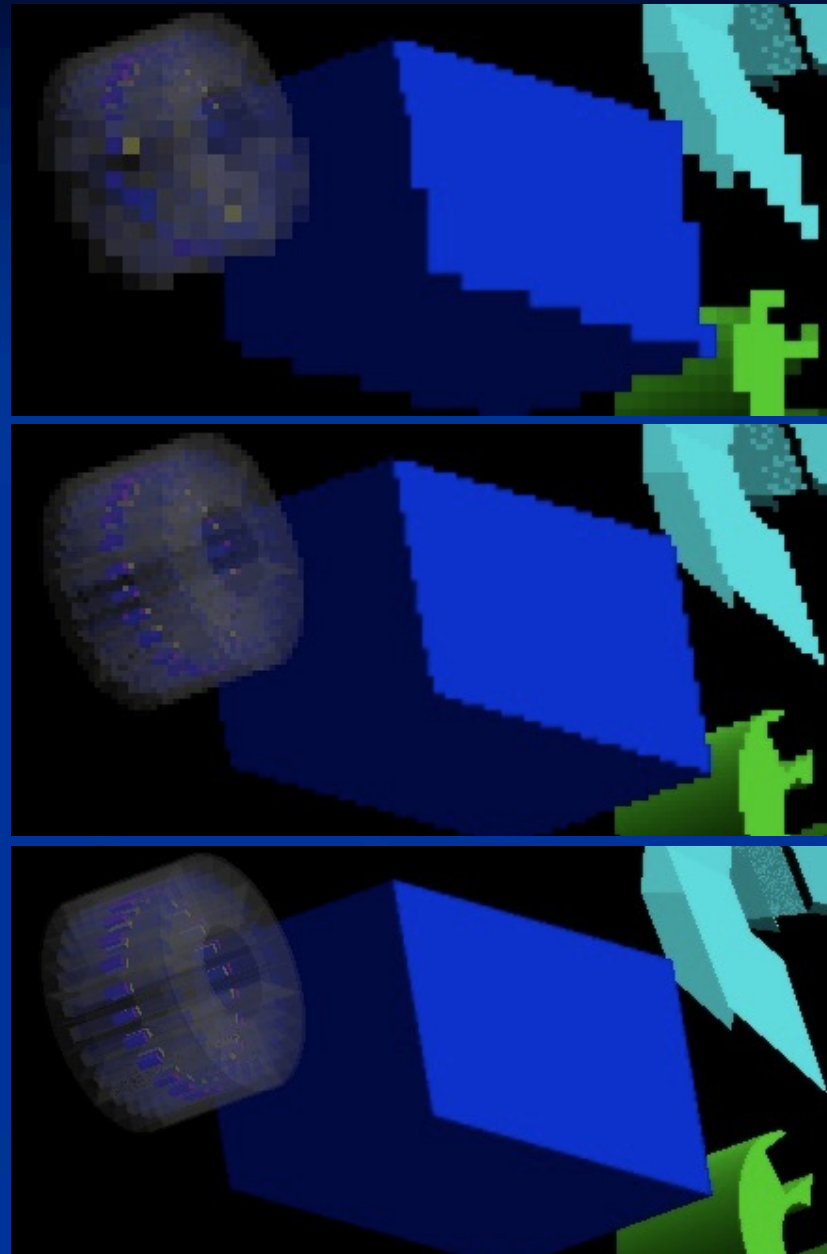

gMocren

Great tool available for volume visualization

- From JST/CREST project (Japan) to improve Geant4 for medical physics
- Able to visualize:
 - Volume data
(including overlay of more than one set)
 - Trajectories
 - Geometry
- Runs on:
 - Windows and Linux
 - Mac will likely happen soon
 - Based on a commercial package but offered freely to all Geant4 users
 - <http://geant4.kek.jp/gMocren>
 - Installation is straightforward, follow the Download link on the above page
 - First run gMocren's one-click installer
 - Then, inside C:\Program Files\gMocren\gtk, you will find the one-click installer for gtk

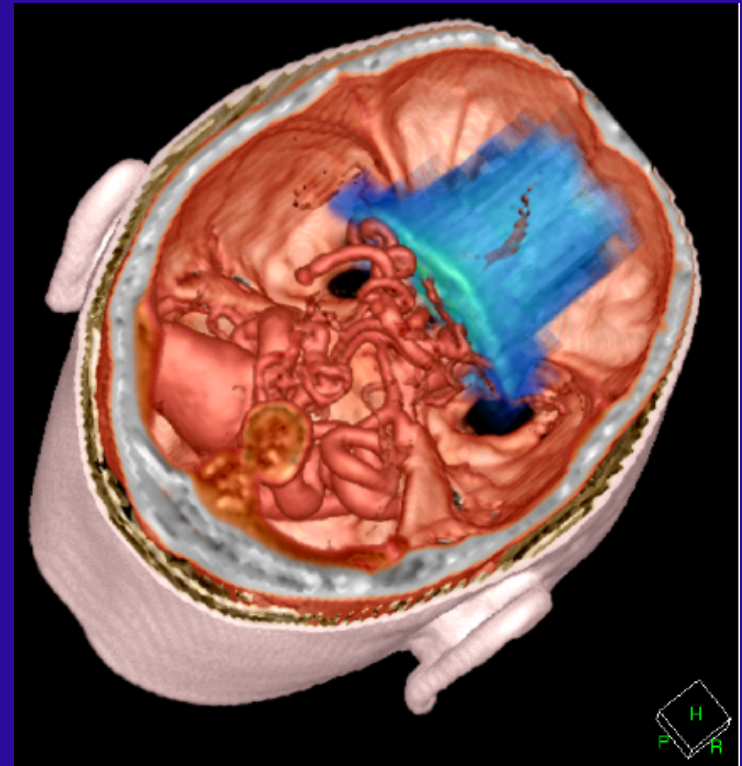

gMocren : A Visualization Tool

<http://geant4.kek.jp/gMocren/>

gMocren and utility software are freely available.

3D (ray casting)

2D (MPR)

Opacity curve and color map editor

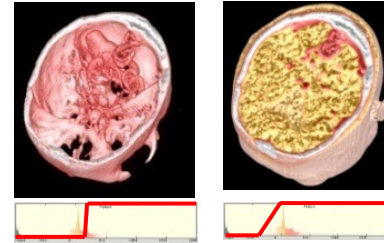
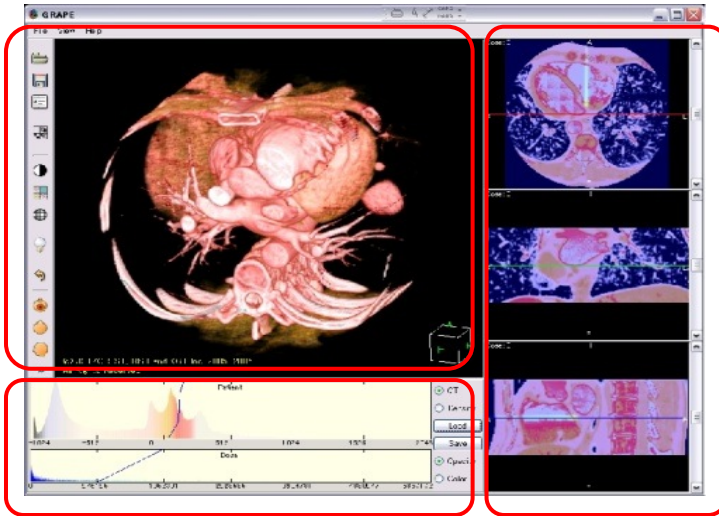

free hand or templates with WW&WL editing

Supported system :
 - Windows 2k/XP or PC Linux OS
 - Pentium 4 or faster
 - more than 1 GB (recommend)

Calculated dose distribution

Particle trajectories

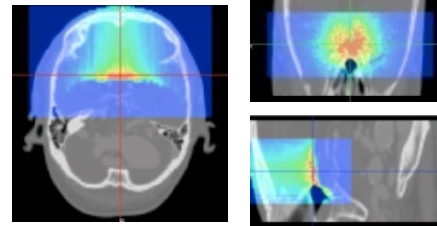

color mapping

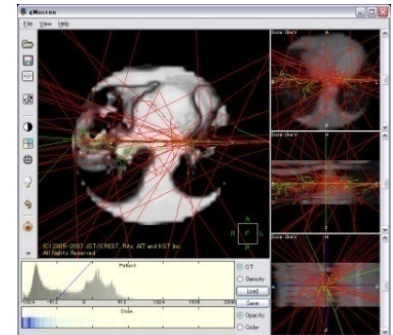

Trajectory information in the simulation is available.

Opacity curve and color map editor

Functionality Requirements :

- To visualize
 - the modality image used by the simulation,
 - the calculated dose distribution and
 - the particle trajectories
- in an agreeable speed
- Transfer function editor
- Multi-platform

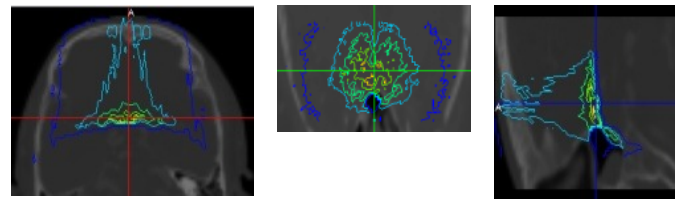

contour plot

Sample Data available for Download

Copyright © 2006-2008
A.Kimura,
K.Hasegawa,
A.Saitoh, S.Tanaka,
and JST.
All rights reserved.

Top Page

News & Updates

System Requirements

Manual (English)

Manual (Japanese)

Tutorial (English)

Tutorial (Japanese)

Sample Data

We provide sample data in this page.

GDD files

- [a chest data \(5.2 MB\)](#)
- [a head data \(1.9 MB\)](#)
- [a chest data with color trajectories \(0.5 MB\)](#)

(to download a data file, right-click the link and click 'save as')

gMocren File Driver

- To export Geant4 visualization to gMocren files:
 - /vis/open gMocrenFile
 - /vis/scene/add/psHits
 - /vis/viewer/flush
 - many other options available with /score/draw ... commands

ASCIITree

- `/vis/open ATree`
- Features
 - Text dump of the geometry hierarchy
 - Not graphical
 - Control over level of detail to be dumped
 - Can calculate mass and volume of any hierarchy of volumes
- Supported by John Allison

ASCIITree

- ASCIITREE is a visualization driver that is not actually graphical, but that dumps the hierarchy as a simple text tree.
 - `/vis/open ATree`
- `/vis/viewer/flush`
 - `"worldPhysical":0`
 - `"magneticPhysical":0`
 - `"firstArmPhysical":0`
 - `"hodoscope1Physical":0`
 - `"hodoscope1Physical":1` (repeated placement)
 - `"hodoscope1Physical":2` (repeated placement)
 - `"hodoscope1Physical":3` (repeated placement)
 - `"hodoscope1Physical":4` (repeated placement)
- Can be set to various levels of detail
 - `/vis/ASCIITree/verbose <verbosity>`
 - 0: prints physical volume name.
 - 1: prints logical volume name.
 - 2: prints solid name and type.
 - 3: prints volume and density of solid.
 - 4: calculates and prints mass(es) of volume(s) in scene.
 - By default, shows only daughters of first placement and not repeat replicas.
 - Add 10 to the above to also show repeated placements and replicas.

ASCIITree: Calculate Volume and Mass

- At verbosity level 4, ASCIITree calculates the mass of the complete geometry tree taking into account daughters up to the depth specified for each physical volume.
- The calculation involves subtracting the mass of that part of the mother that is occupied by each daughter and then adding the mass of the daughter, and so on down the hierarchy.
- /vis/ASCIITree/Verbose 4
- /vis/viewer/flush
- "HadCalorimeterPhysical":0 / "HadCalorimeterLogical" / "HadCalorimeterBox"(G4Box), 1.8 m³ , 11.35 g/cm³
 - "HadCalColumnPhysical":-1 (10 replicas) / "HadCalColumnLogical" / "HadCalColumnBox"(G4Box), 180000 cm³, 11.35 g/cm³
 - "HadCalCellPhysical":-1 (2 replicas) / "HadCalCellLogical" / "HadCalCellBox"(G4Box), 90000 cm³, 11.35 g/cm³
 - "HadCalLayerPhysical":-1 (20 replicas) / "HadCalLayerLogical" / "HadCalLayerBox"(G4Box), 4500 cm³, 11.35 g/cm³
 - "HadCalScintiPhysical":0 / "HadCalScintiLogical" / "HadCalScintiBox"(G4Box), 900 cm³, 1.032 g/cm³
- Calculating mass(es)...
 - Overall volume of "worldPhysical":0, is 2400 m³
 - Mass of tree to unlimited depth is 22260.5 kg

Summary and Further Resources

Choose the Driver that Meets Your Needs

- If you want very responsive photorealistic graphics (and have the OpenGL libraries installed)
 - OpenGL is a good solution
- If you want the above plus more interactivity (and have Qt or OpenInventor libraries installed)
 - OpenGL Qt or OpenInventor are good solutions
- If you want GUI control, want to be able to pick on items to inquire about them (identity, momentum, etc.), perhaps want to render to vector formats, and a wireframe look will do
 - HepRep will meet your needs
- If you want to render highest quality photorealistic images for use in a poster or a technical design report, and you can live without quick rotate and zoom
 - DAWN is the way to go
- If you want to render to a 3D format that others can view in a web browser plug-ins
 - VRML is the way to go
- If you want to visualize a geometry that the other visualization drivers can't handle, or you need transparency or mirrors, and you don't need to visualize trajectories
 - RayTracer will do it
- If you want to visualize volume data, such as dose to tissue in medical physics
 - gMocren will do it
- If you just want to quickly check the geometry hierarchy, or if you want to calculate the volume or mass of any geometry hierarchy
 - ASCIITree will meet your needs

Details

- Some drivers are always present, others require setting of environment variables (since they require external libraries)
 - The ./Configure procedure helps you set these variables
- You can explore the online command guidance to learn the extensive set of visualization commands
 - Just type “help” at the Geant4 idle prompt
- You can also add your own visualization driver.
 - Geant4’s visualization system is modular. By creating just three new classes, you can direct Geant4 information to your own visualization system.
- You can even open more than one driver at a time.
 - For example, do a quick check in OpenGL, then save a beautiful DAWN plot. See talk on Visualization Commands.

Two Page Summary of Visualization Drivers (1)

- OpenGL
 - Control directly from Geant4
 - Uses GL libraries that are already included on most Linux and Windows systems
 - Rendered, photorealistic image with some interactive features
 - zoom, rotate, translate
 - Fast response (can usually exploit full potential of graphics hardware)
 - Print as pixel graphics or vector EPS
 - Additional interactive control if you have the Qt or Motif libraries installed and configured
 - Movies
- OpenInventor
 - Control from the OpenInventor GUI
 - Requires addition of OpenInventor libraries (freely available for most Linux and Windows systems).
 - Rendered, photorealistic image
 - Many interactive features
 - zoom, rotate, translate
 - click to “see inside” opaque volumes
 - click to show attributes (momentum, etc., dumps to standard output)
 - Fast response (can usually exploit full potential of graphics hardware)
 - Expanded printing ability (vector and pixel graphics)
- HepRep
 - Create a file to view in the HepRApp HepRep Browser, WIRED4 Jas Plugin or FRED Event Display
 - Requires one of the above browsers (freely available for all systems)
 - Wireframe or simple area fills (not photorealistic)
 - Many interactive features
 - zoom, rotate, translate
 - click to show attributes (momentum, etc.)
 - special projections (FishEye, etc.)
 - control visibility from hierarchical (tree) view of data
 - Hierarchical view of the geometry
 - Export to many vector graphic formats (PostScript, PDF, etc.)

Two Page Summary of Visualization Drivers (2)

- DAWN
 - Create a file to view in the DAWN Renderer
 - Requires DAWN, available for all Linux and Windows systems.
 - Rendered, photorealistic image
 - No interactive features once at PostScript stage
 - Highest quality technical rendering - vector PostScript
 - View or print from your favorite PostScript application
- VRML
 - Create a file to view in any VRML browser (some as web browser plug-ins).
 - Requires VRML browser (many different choices for different operating systems).
 - Rendered, photorealistic image with some interactive features
 - zoom, rotate, translate
 - Limited printing ability (pixel graphics, not vector graphics)
- RayTracer
 - Create a jpeg file (and with RayTracerX option, also draws to x window)
 - Forms image by using Geant4's own tracking to follow photons through the detector
 - Can show geometry but not trajectories
 - Can render any geometry that Geant4 can handle (such as Boolean solids)
 - no other Vis driver can handle every case
 - Supports shadows, transparency and mirrored surfaces
- gMocren
 - Create a file to view in the gMocren browser.
 - Requires gMocren, available for all Linux and Windows systems (with Mac coming soon)
 - Can overlay patient scan data (from DICOM) with Geant4 geometry, trajectories and dose
- ASCII Tree
 - Text dump of the geometry hierarchy (not graphical)
 - Control over level of detail to be dumped
 - Can calculate mass and volume of any hierarchy of volumes

Geant4 Visualization Resources

Geant4 Installation Guides

➤ <http://geant4.slac.stanford.edu/installation>

Hands on HepRApp Tutorial

➤ <http://geant4.slac.stanford.edu/Presentations/vis/G4HepRAppTutorial/G4HepRAppTutorial.html>

Hands on DAWN Tutorial

➤ <http://geant4.slac.stanford.edu/Presentations/vis/G4DAWNTutorial/G4DAWNTutorial.html>

Hands on OpenGL Tutorial

➤ <http://geant4.slac.stanford.edu/Presentations/vis/G4OpenGLTutorial/G4OpenGLTutorial.html>

Geant4 Visualization Commands

➤ <http://geant4.slac.stanford.edu/Presentations/vis/G4VisCommands.ppt> (and .pdf)

Geant4 Advanced Visualization

➤ <http://geant4.slac.stanford.edu/Presentations/vis/G4VisAdvanced.ppt> (and .pdf)

How to Make a Movie

➤ <http://geant4.slac.stanford.edu/Presentations/vis/HowToMakeAMovie.ppt> (and .pdf)

Visualization Chapter of the Geant4 User's Guide for Application Developers

➤ <http://geant4.web.cern.ch/geant4/UserDocumentation/UsersGuides/ForApplicationDeveloper/html/>

List of Visualization Commands:

➤ http://geant4.web.cern.ch/geant4/UserDocumentation/UsersGuides/ForApplicationDeveloper/html/AllResources/Control/UIcommands/_vis_.html

For Questions or Comments: Geant4 Visualization Online Forum:

➤ <http://geant4-hn.slac.stanford.edu:5090/HyperNews/public/get/visualization.html>

References

- OpenScientist Home Page
<http://openscientist.lal.in2p3.fr>
- HepRep: a generic interface definition for HEP event display representables
<http://www.slac.stanford.edu/~perl/heprep>
- HepRApp HepRep Browser
<http://www.slac.stanford.edu/~perl/HepRApp>
- Wired4 JAS Plug-In
<http://wired.freehep.org>
- Fred: oh no, another event display (a HepRep client)
<http://www.fisica.uniud.it/~glast/FRED>
- DAWN Home Page
http://geant4.kek.jp/~tanaka/DAWN/About_DAWN.html
- DAWNCUT Home Page
http://geant4.kek.jp/~tanaka/DAWN/About_DAWNCUT.html
- DAVID Home Page
http://geant4.kek.jp/~tanaka/DAWN/About_DAVID.html
- Satoshi Tanaka's GEANT4 Ritsumeikan University Group Home Page (more information on DAWN, sample PRIM files, images, etc.)
<http://geant4.kek.jp/~tanaka/>
- gMocren Home Page
<http://geant4.kek.jp/gMocren>