



# Romanian HSSIP 2021

## Project 9: Life cycle of a component of an accelerator (crab cavities)

---

ANDA-ALEXANDRA DRAGOMIR; CODRIN BERINDE  
SUPERVISORS: IULIANA TABIAN, OFELIA CAPATINA

THANKS TO: FEDERICO CARRA, SIMON BARRIERE, ROMAIN NINET, ROMAIN GERARD, OSCAR SACRISSTAN DE FRUTOS, MICHAEL GUINCHARD, IGNACIO AVILES SANTILLANA, ADRIA GALLIFA TERRICABRAS, TEDDY CAPELLI, LUCIE BAUDIN, JORGE GUARDIA VALENZUELA, NIKOLINA VEJNOVIC, MARCO MASCI, LIVIA CARMEN COMAN, KEZIBAN KANDEMIR, VALENTINA CASADEI AND MANY MORE ...

# Collision at present

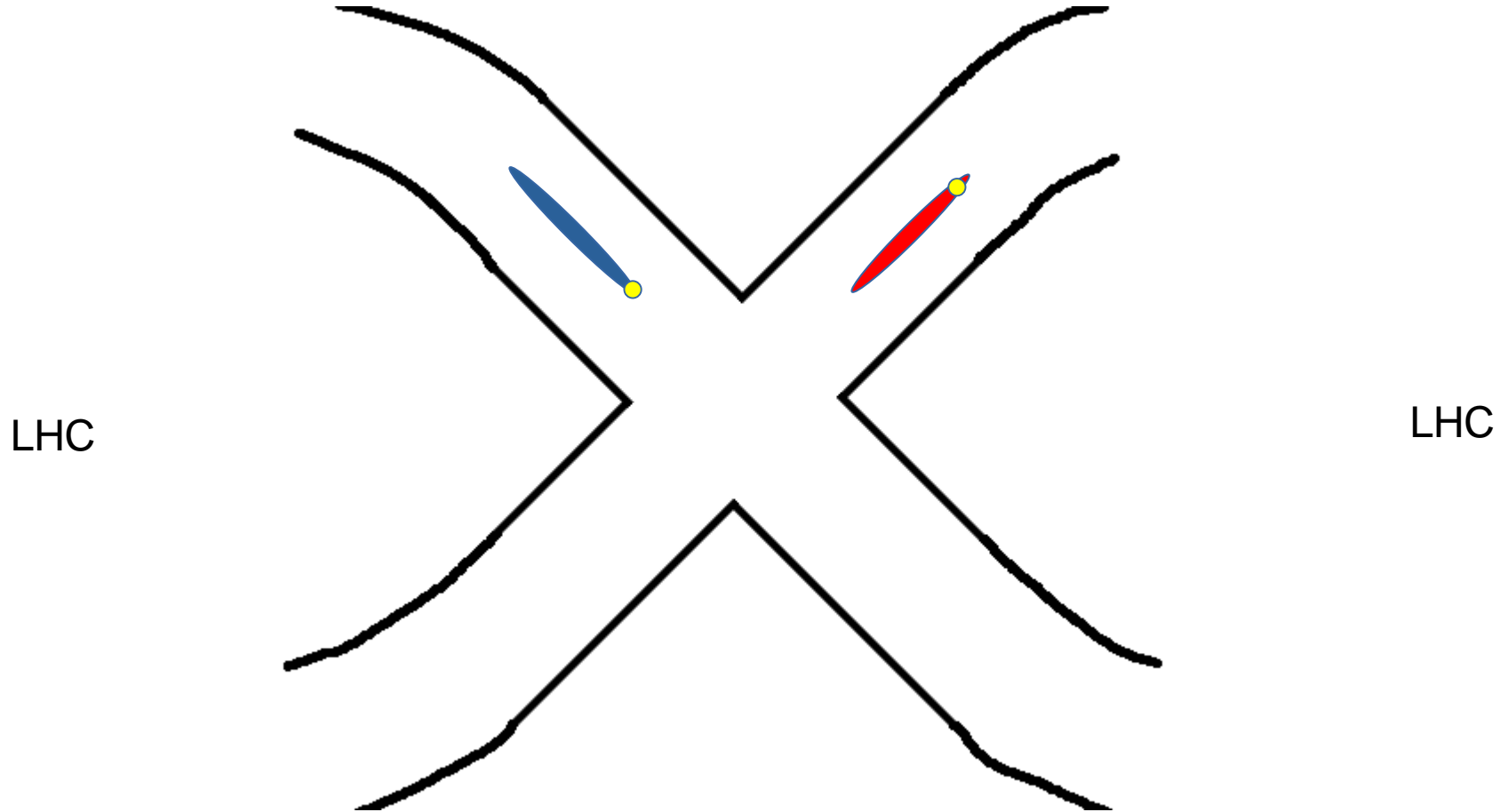

# With Crab Cavities

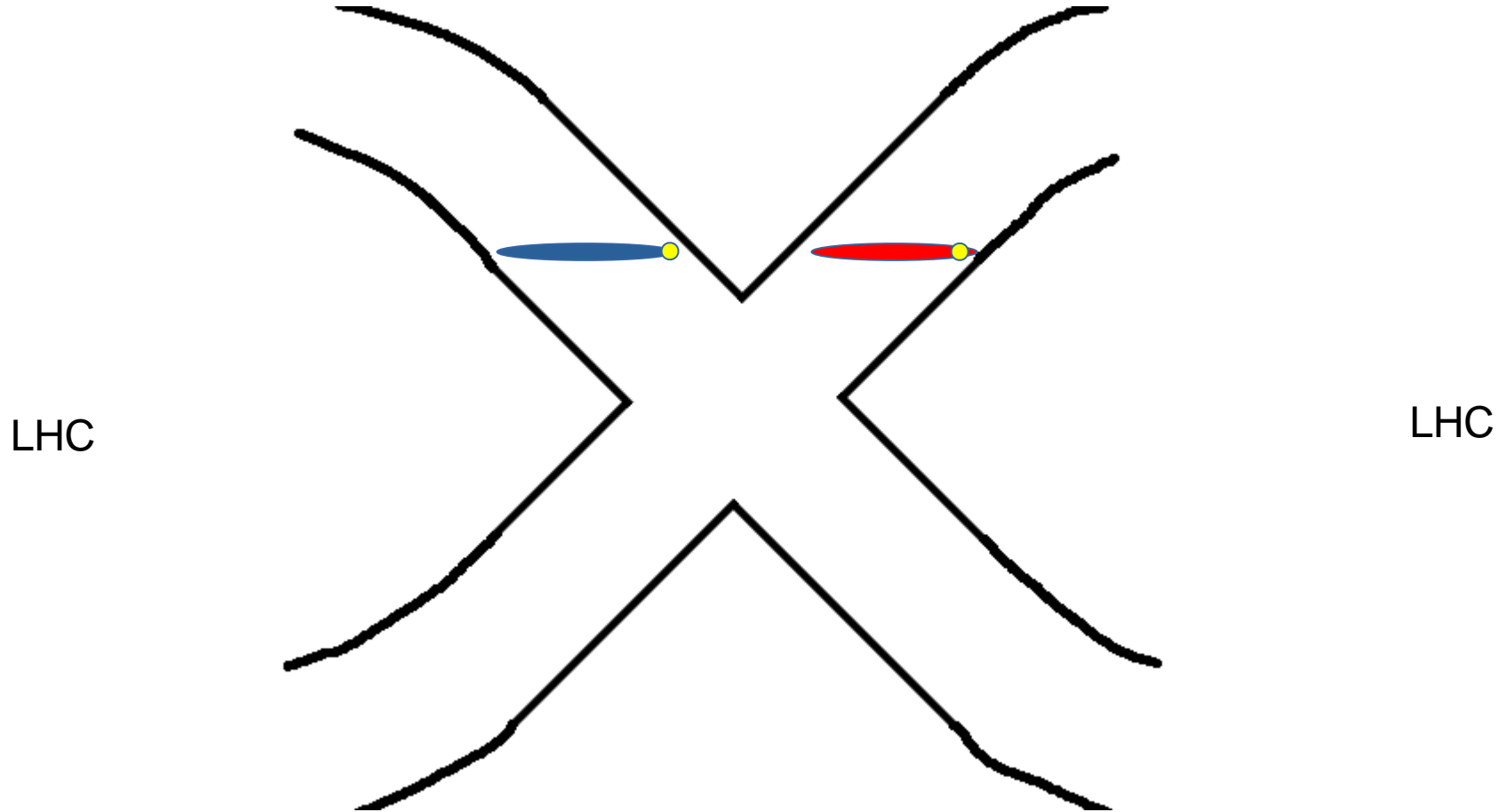

# Crab Cavities

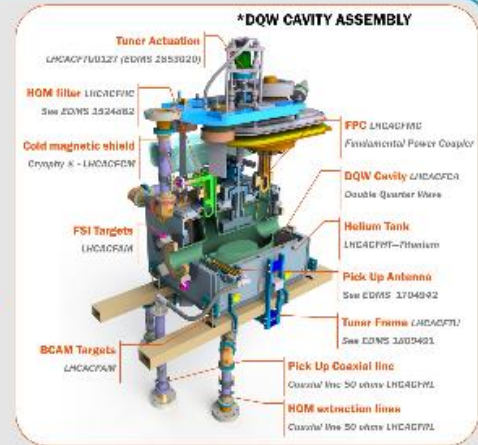
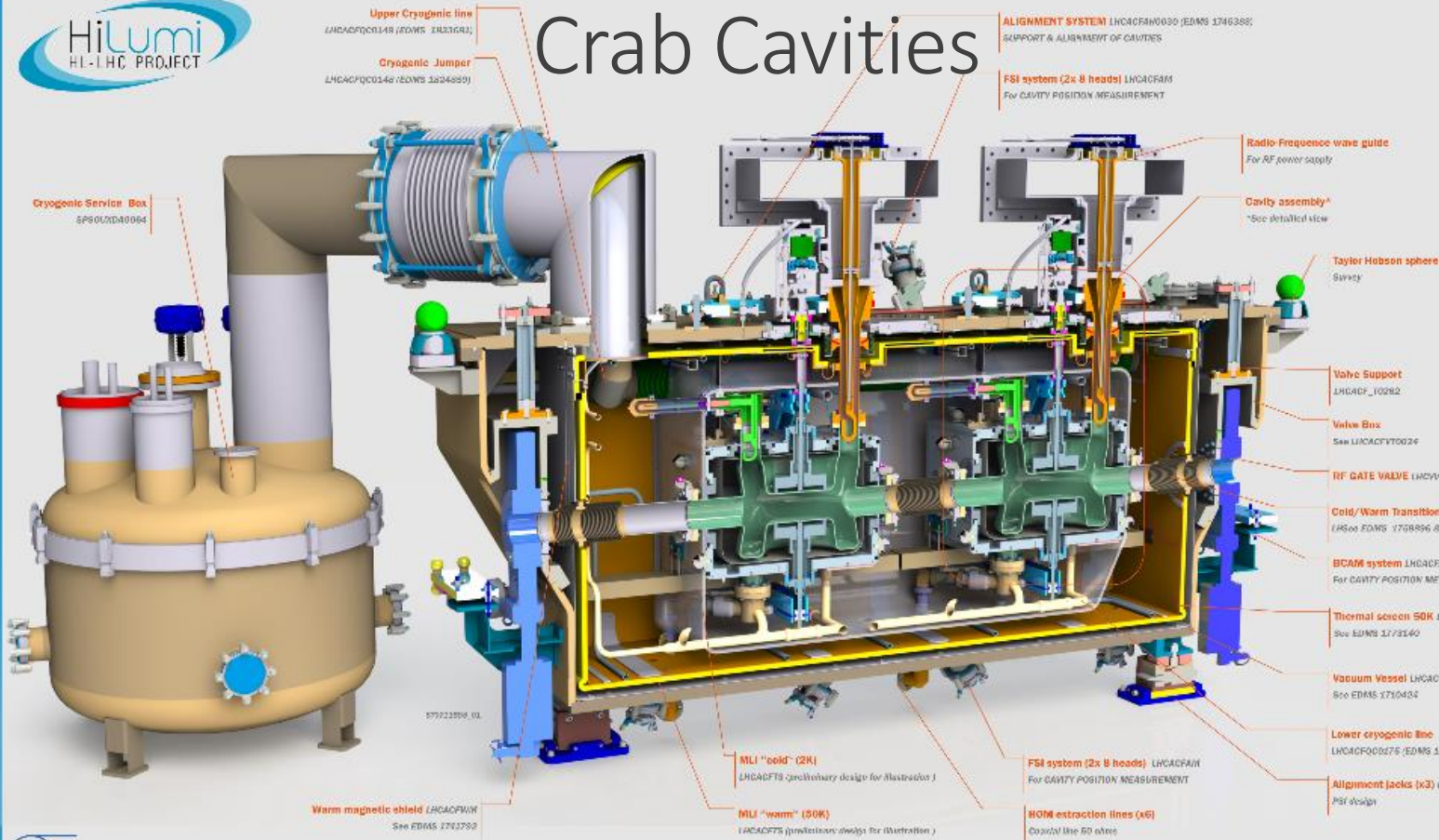

### Information about DQW cryomodules

- Overall dimensions (L/l/h): 2800/950/1900mm
- Mass : ~3800kg (Without service box)
- Cavity : 2x DQW
- HOM filters : 6 pcs (3 per cavity)
- Pick Up Antenna : 2 pcs (1 per cavity)
- Tuner : 2 unit (1 per cavity)
- RF Gate valves : 2 pcs
- FSI Heads : 16 ports (8 per cavity)
- BCAM : 2 lines / 4 position fingers per cavity



EDMS n. 1729225  
22-03-2027

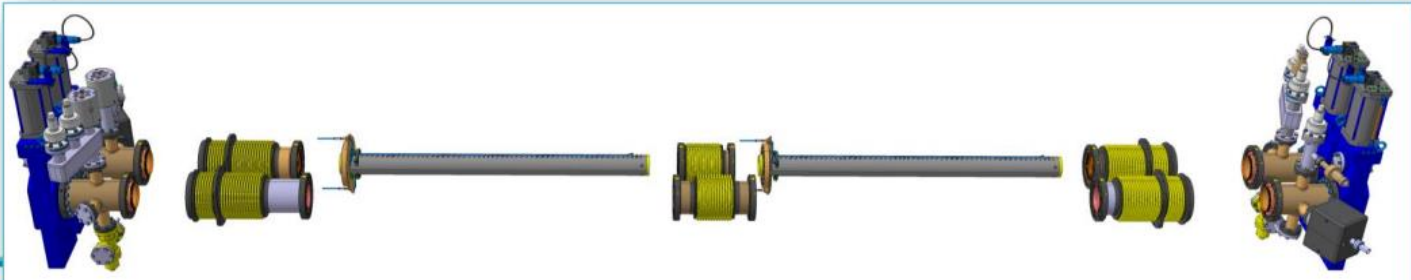
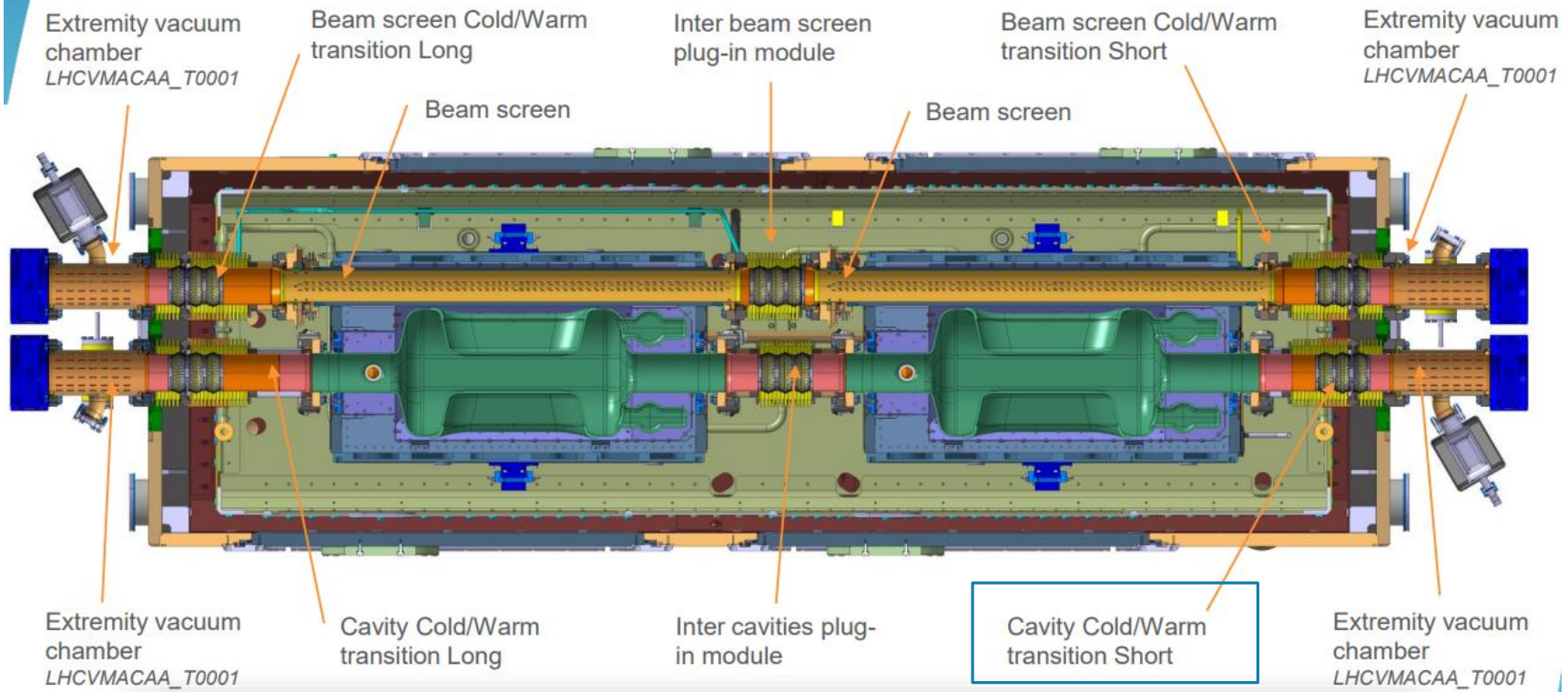

# The RF fingers

- Link components which vary in length due to the change in temperature
- Maintain electrical contact between the two components
- They are made of Copper Beryllium

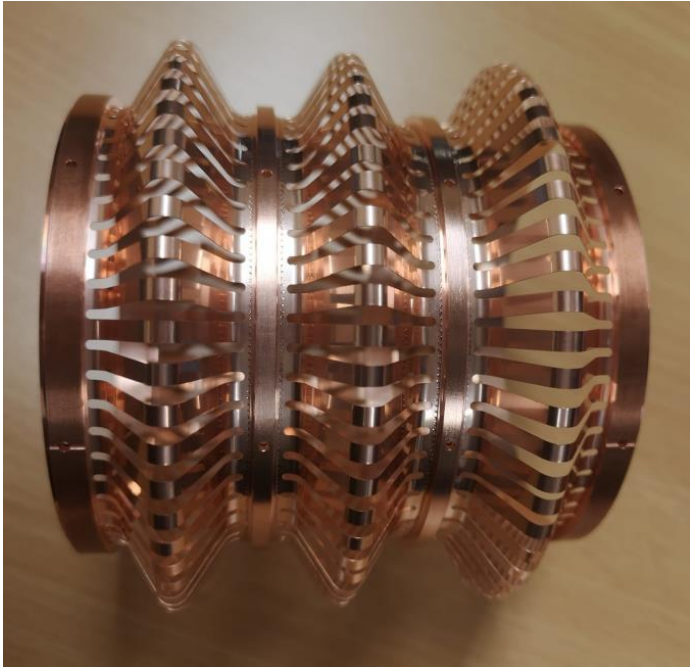
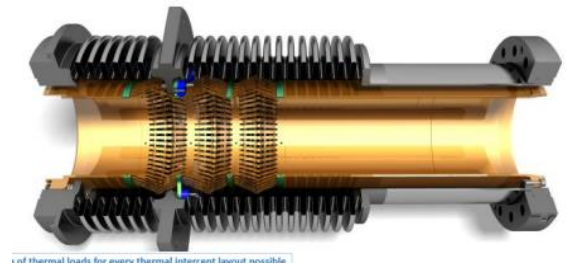

# The life cycle of a component

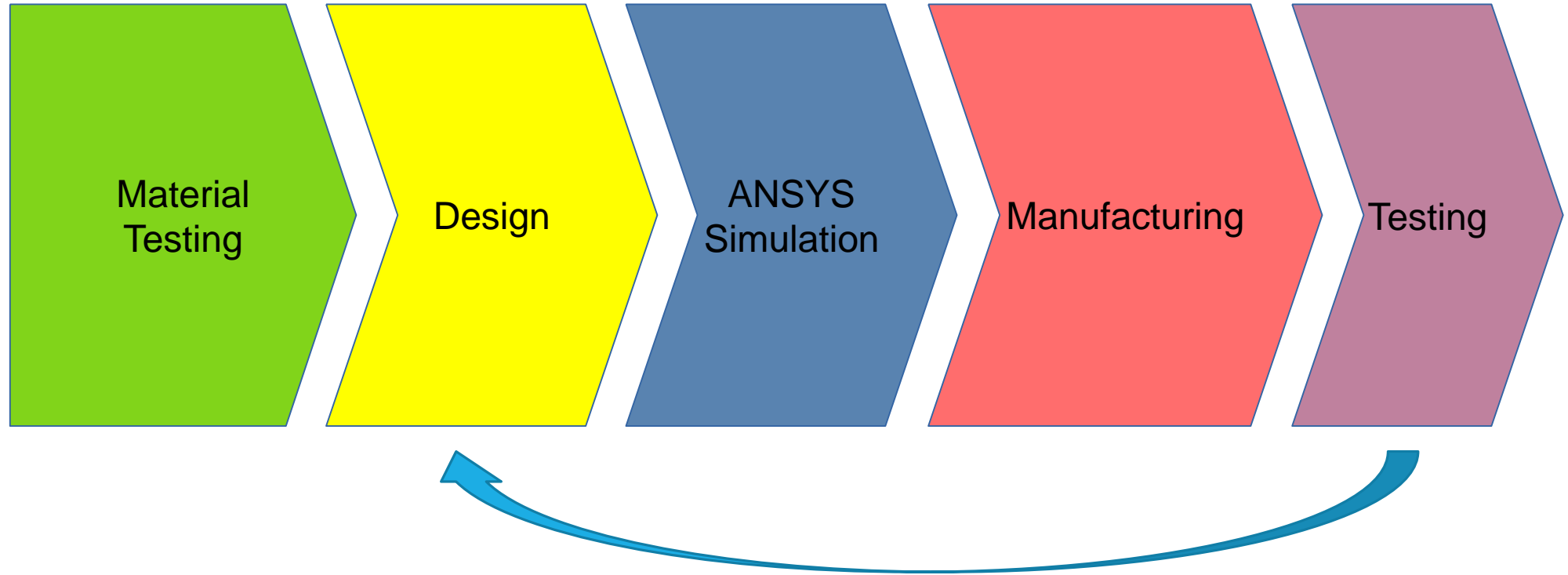

# Mechanical properties of a material

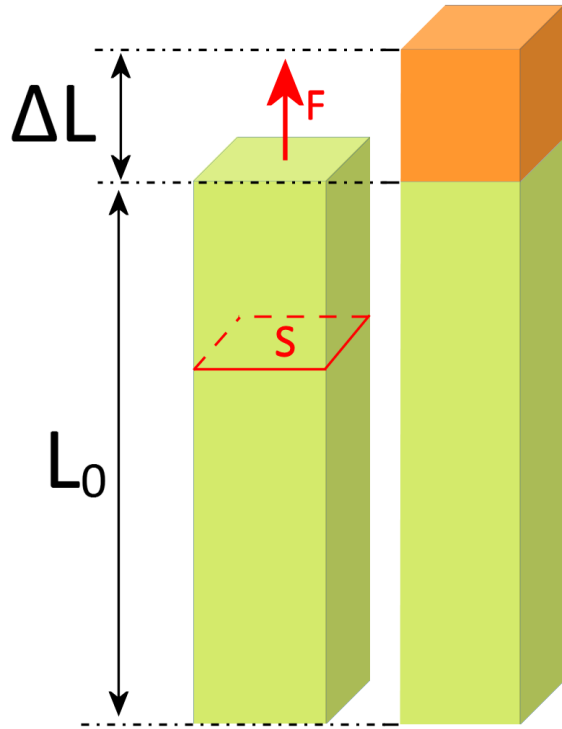

- Stress:  $\sigma = \frac{F}{S}$
- Strain:  $\varepsilon = \frac{\Delta L}{L_0}$

Hooke's Law:

$$\sigma = E\varepsilon$$

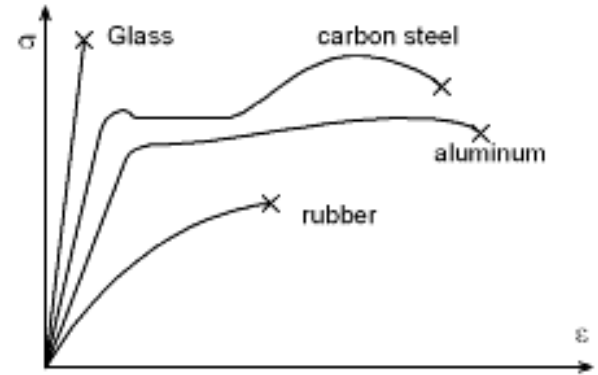



# Determining the mechanical properties of Copper Beryllium

In order to perform such an experiment, specimens made of the material which we are interested in are fixed onto the machine, which will pull the specimen until it breaks.

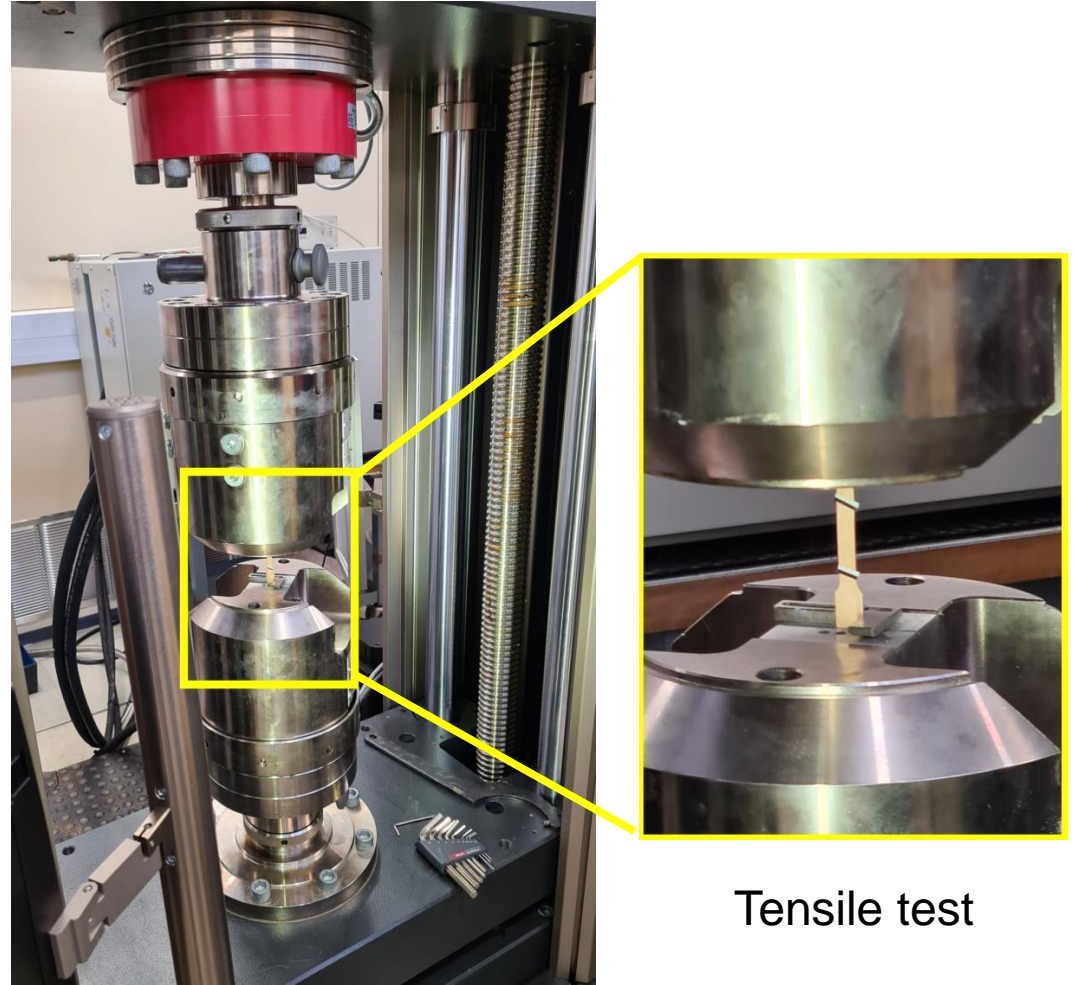
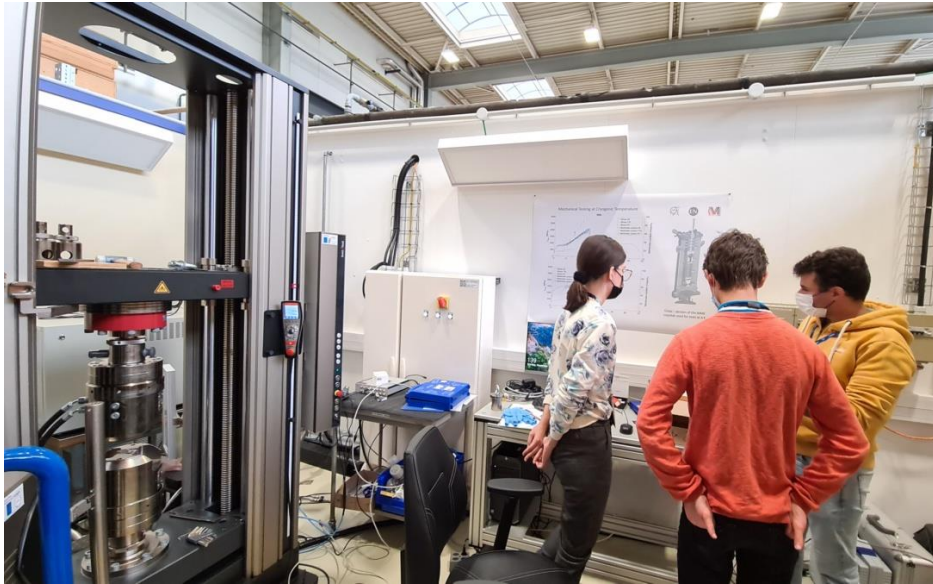

Tensile test

## Observing the behaviour of the component



## After the tensile test

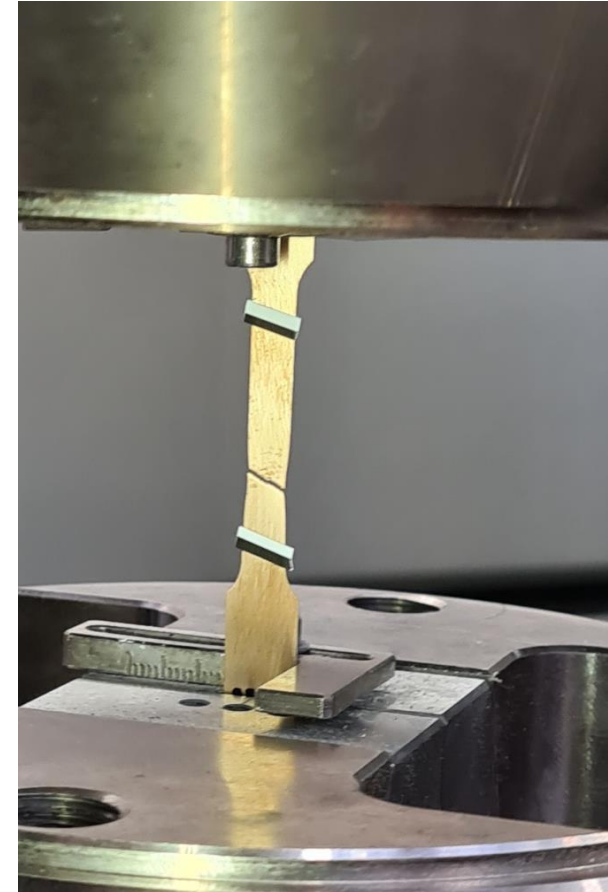

# Results: stress-strain curve

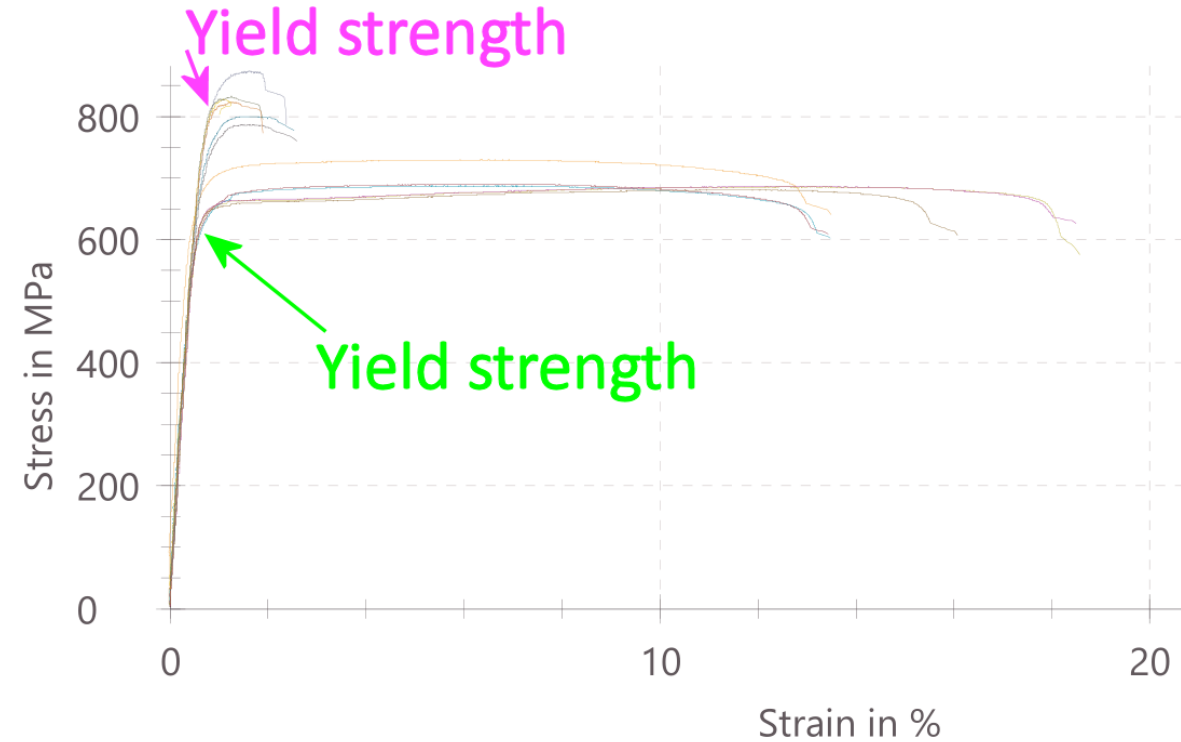

The initial slope is Young's modulus of elasticity (E)

The yield strengths are different due to the fact that we used two types of alloys: the first one had more beryllium in its composition than the second one. The second one elongated more before fracture.

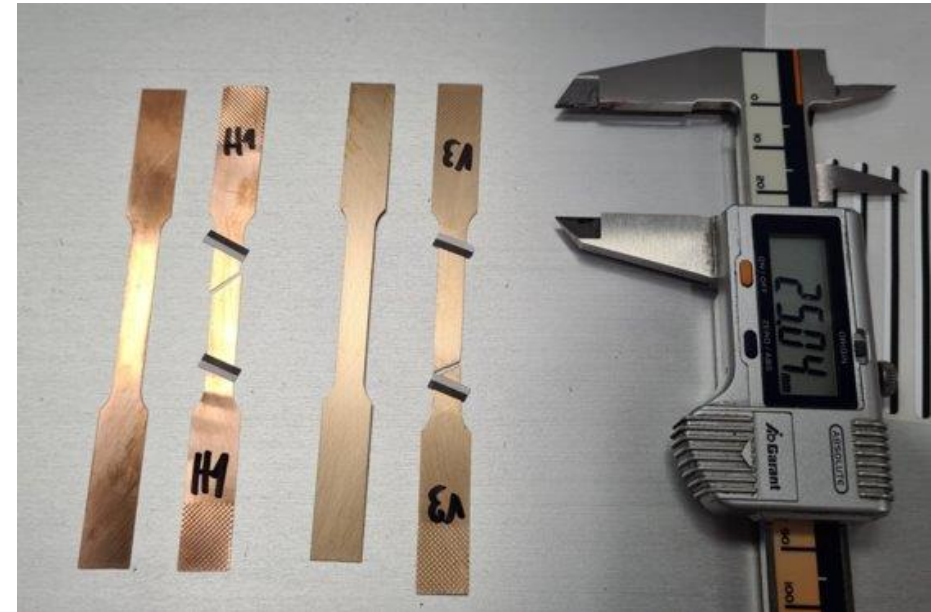

# Design - the main assembly done in CATIA

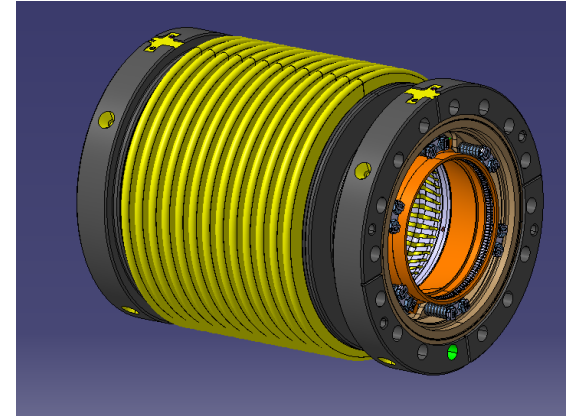
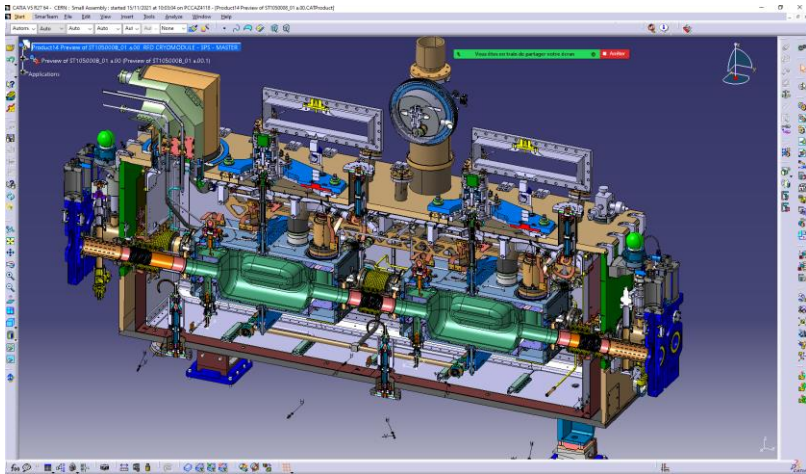
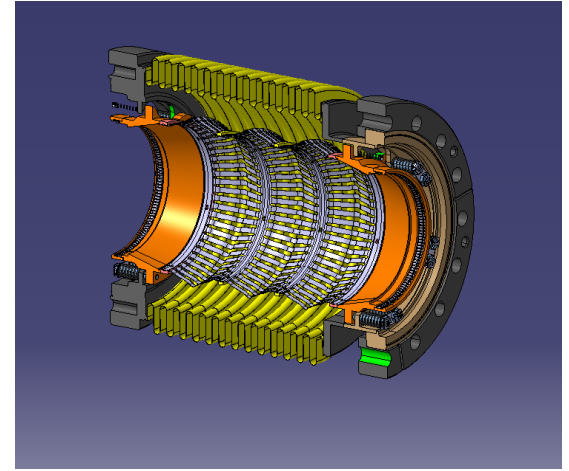
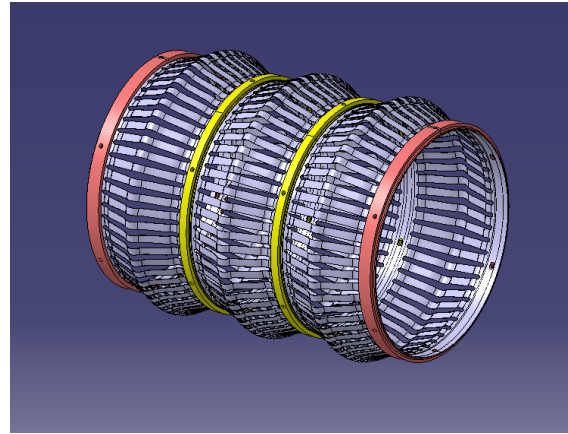
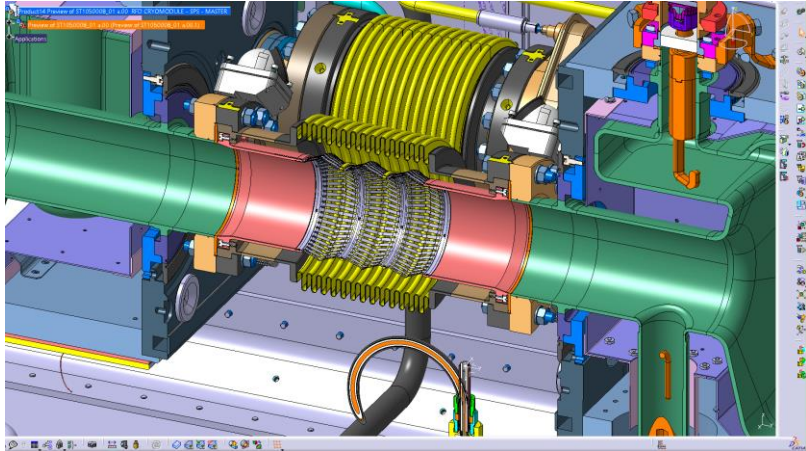



# Simulations in ANSYS

18/11/2021 11:25



**D: WithoutFlanges**

Equivalent Stress

Type: Equivalent (von-Mises) Stress

Unit: MPa

Time: 1

18/11/2021 17:17

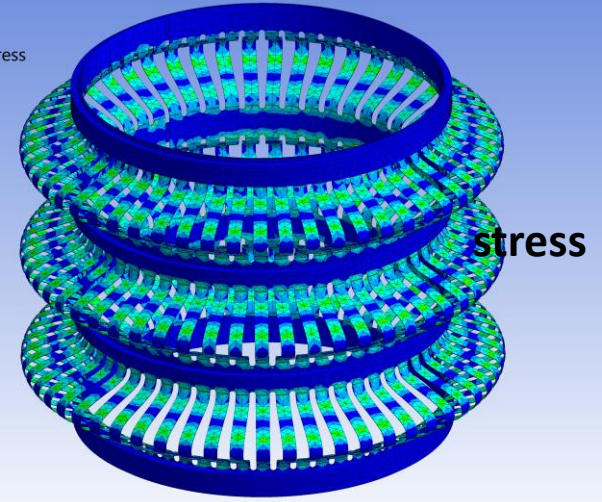

- Based on Finite Element Methods theory (FEM)
- Using SpaceClaim to simplify the geometry of the object
- Using ANSYS to add the material data obtained in the mechanical test (yield strength etc.)
- Generating a mesh
- Adding boundary conditions
- Applying a force of 10 N on the Y axis to simulate the compression test

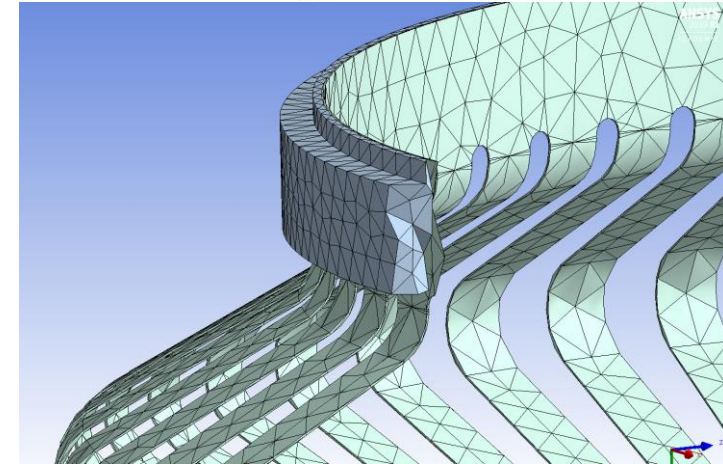

**D: Without flanges**

Total Deformation

Type: Total Deformation

Unit: m

Time: 0

17/11/2021 12:13

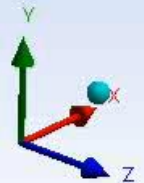
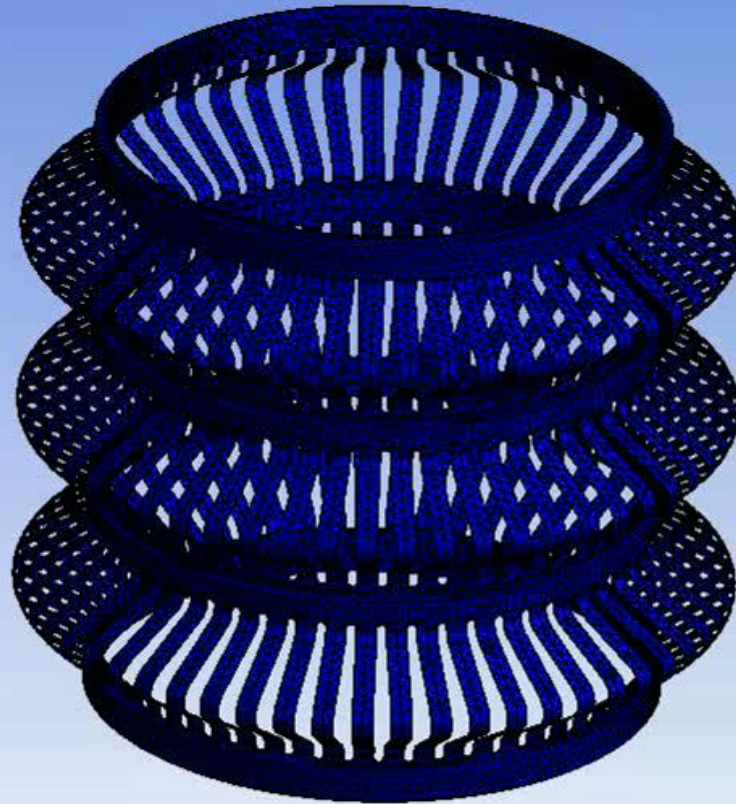
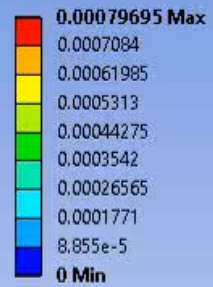





# Assembly

Putting the parts together

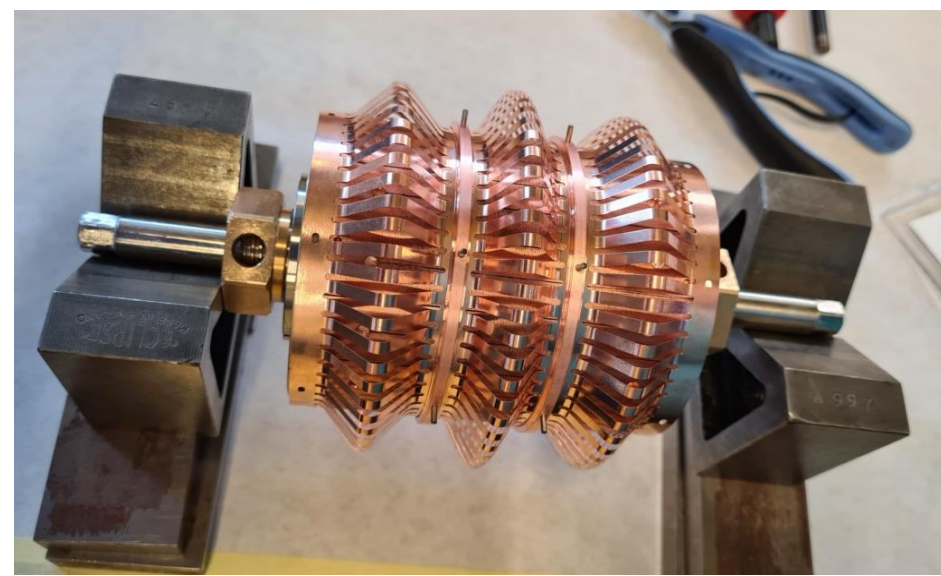
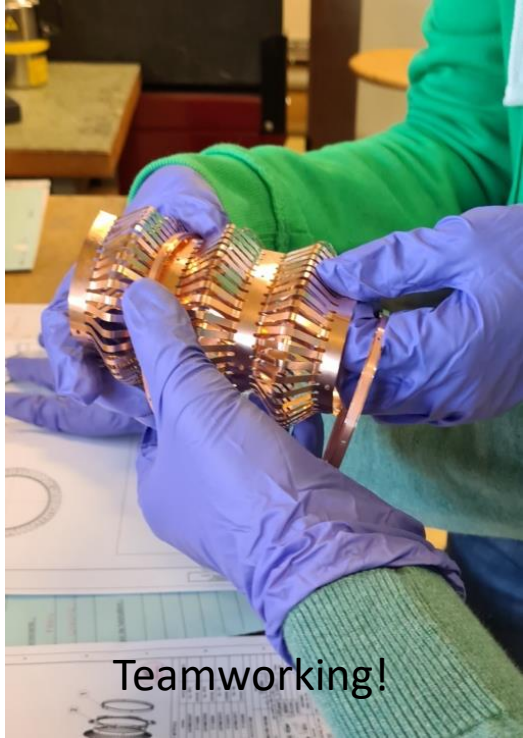

After bending, the rings must be welded onto the sheet.  
For the welding process, the component was put on a support.

# Machining technique: Laser Welding

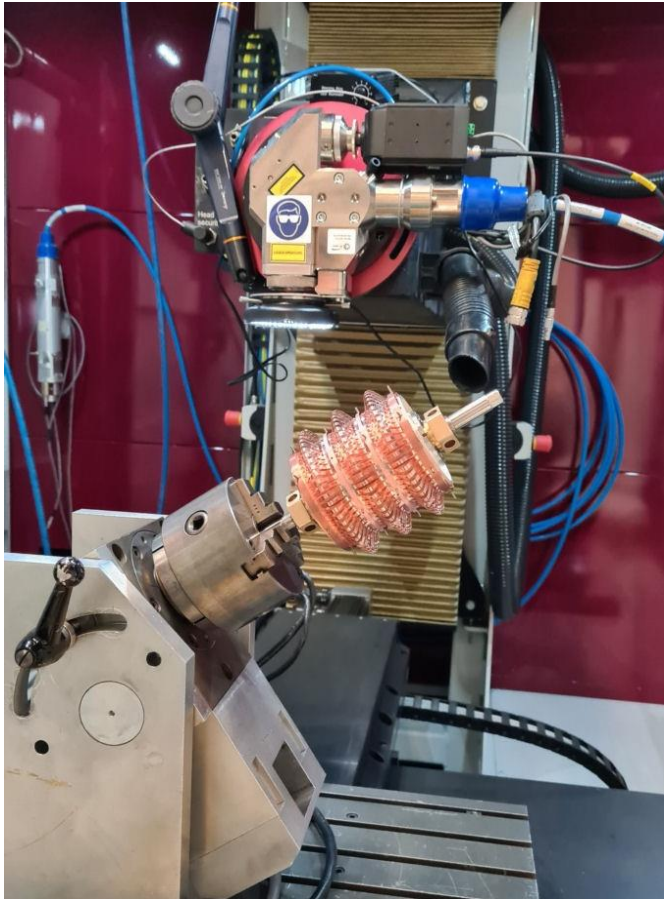

Fixing the component into the welding machine

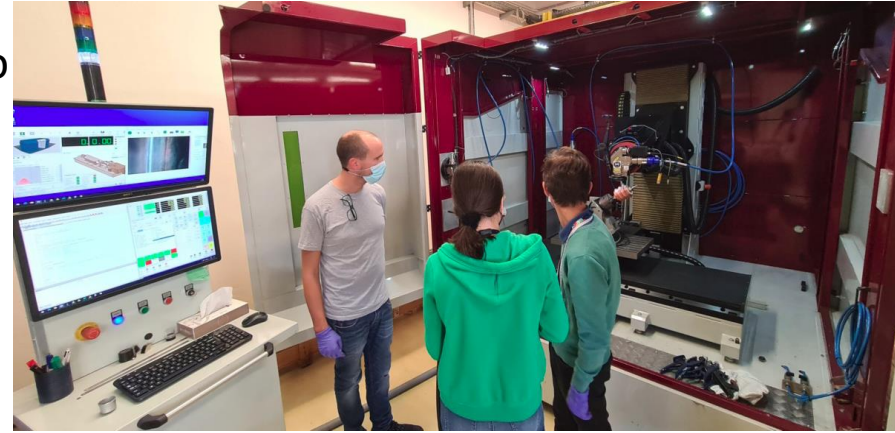

A quick check before pressing the big green button

... and setting the parameters on the computer

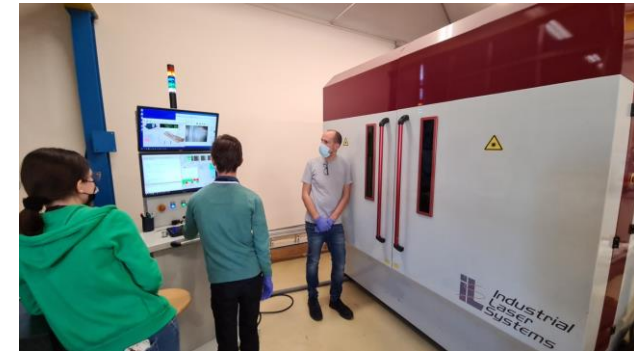

Through the window...

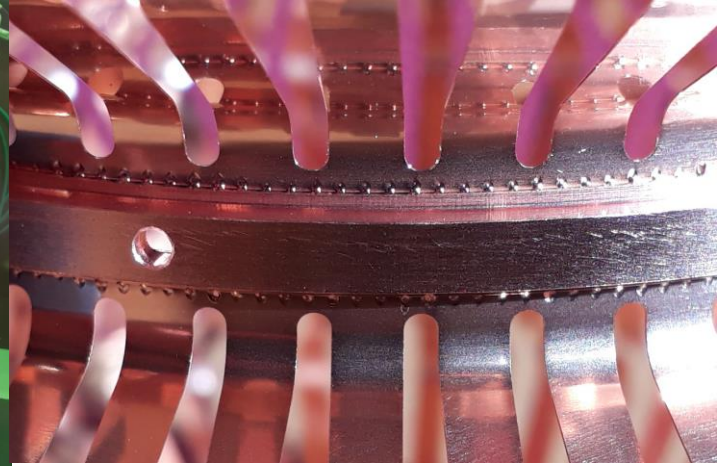
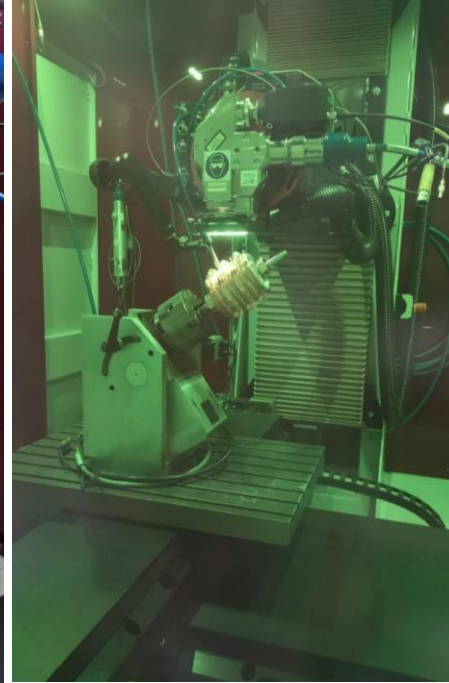

What a nice weld!

# Machining technique: Milling

We used milling (the tool is moving and the object is static) to manufacture two flanges, which we connected to the lower and upper parts of the RF fingers in case we wanted to use them later, in the compression test.

Measuring the block  
of material



Calibrating the piece



The initial piece of Aluminium



The milling machine

# Programming the milling pattern on the computer

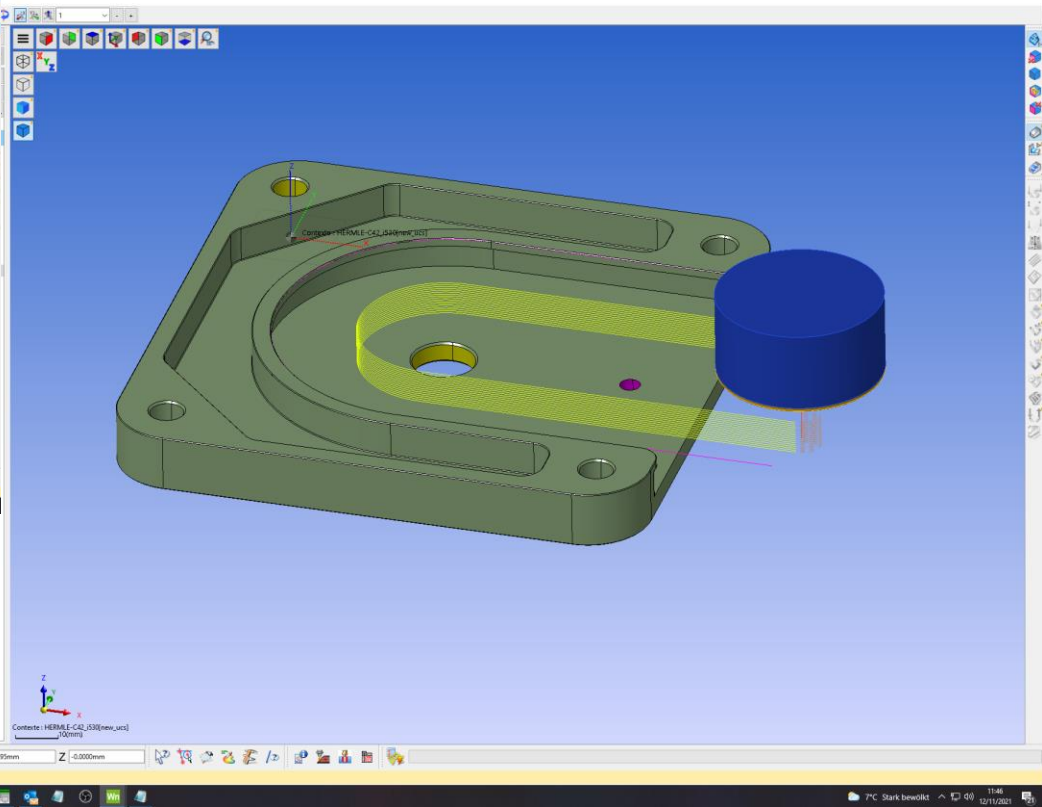
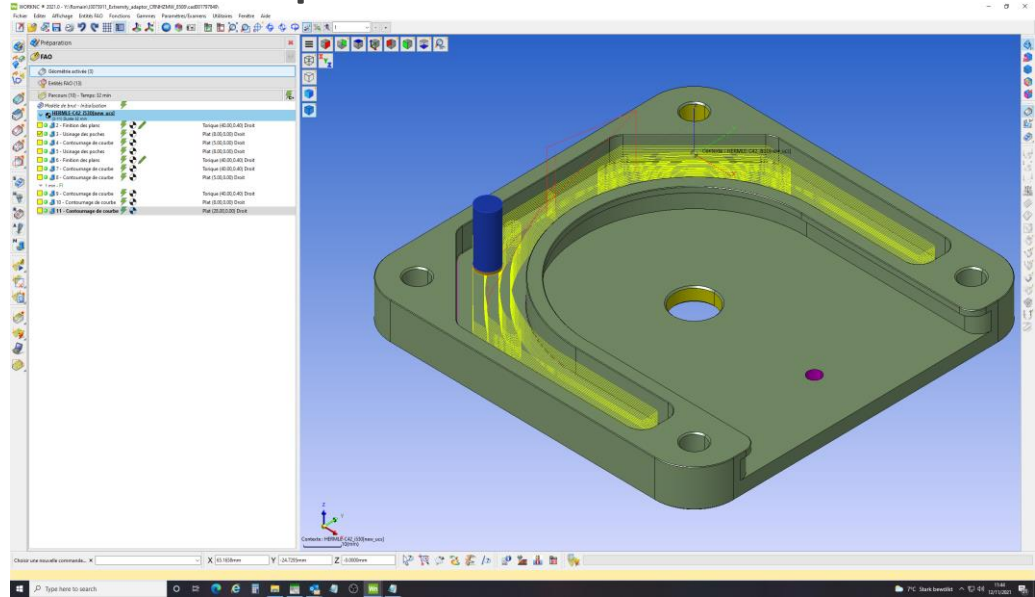

# After milling

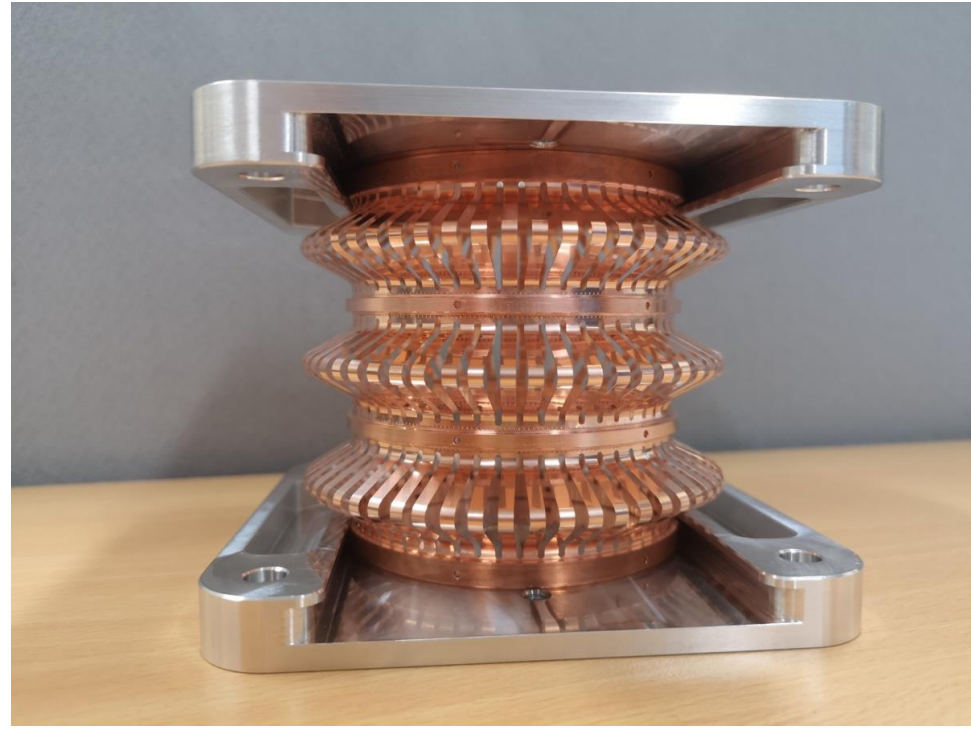

# Testing the component

- The component's behaviour was simulated on the computer, but now it's time to test its real behaviour!
- The RF fingers were sprayed with a white substance (talc) and then with a black substance (graphite powder) to create a high contrast dotted surface.

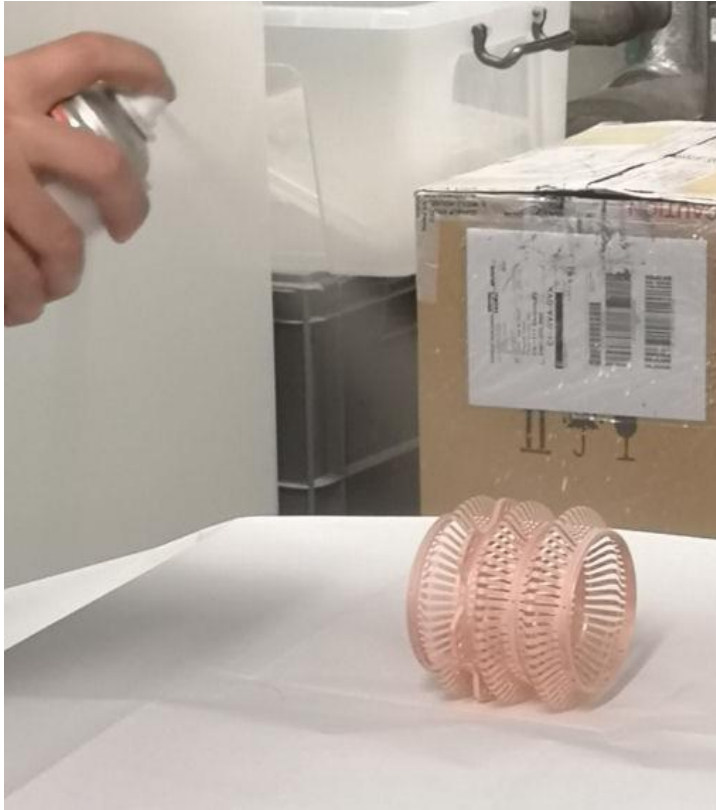

Fixing the component into the machine

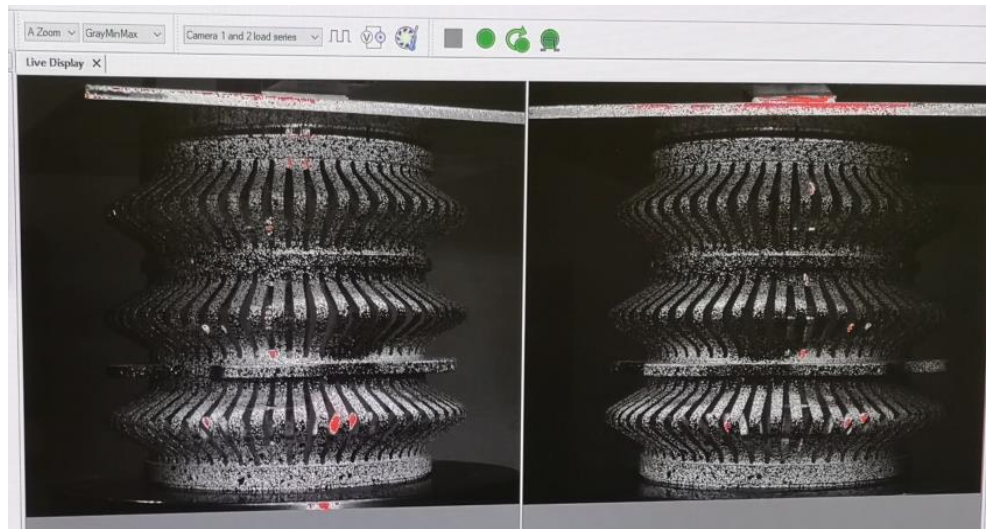
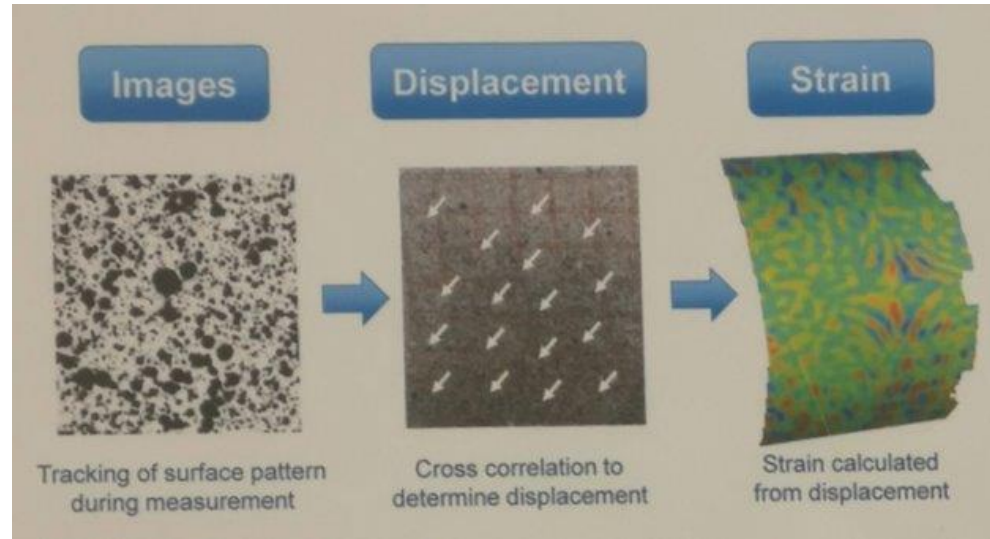
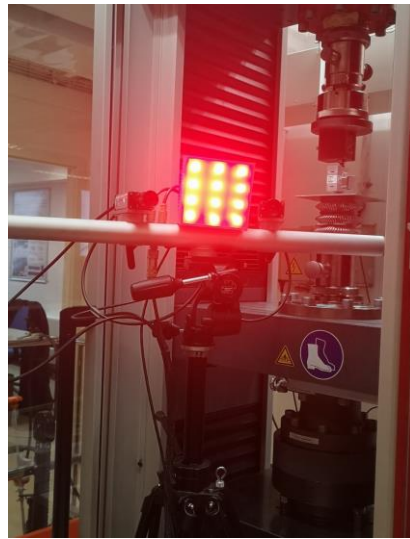
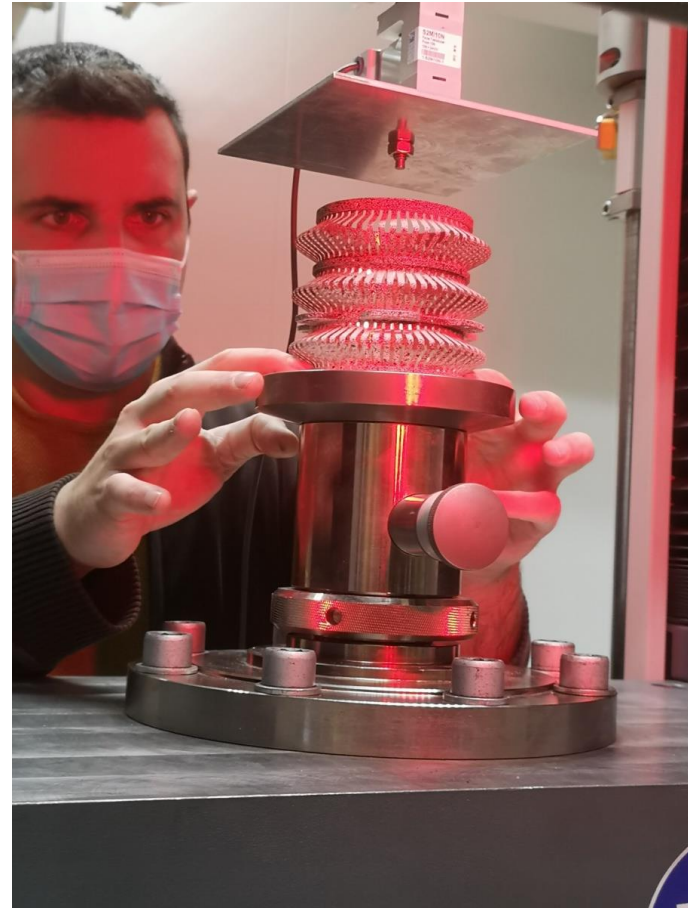

Digital Image Correlation (DIC)



# Testing the component through compression

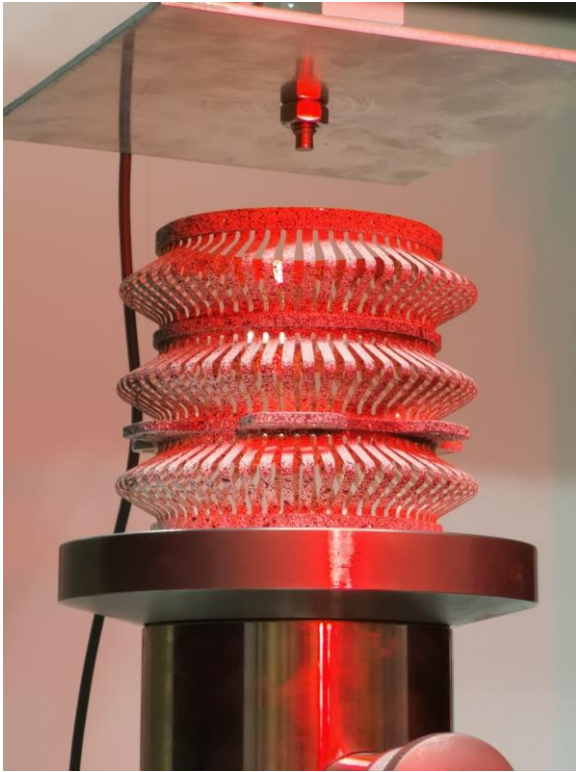

0 N

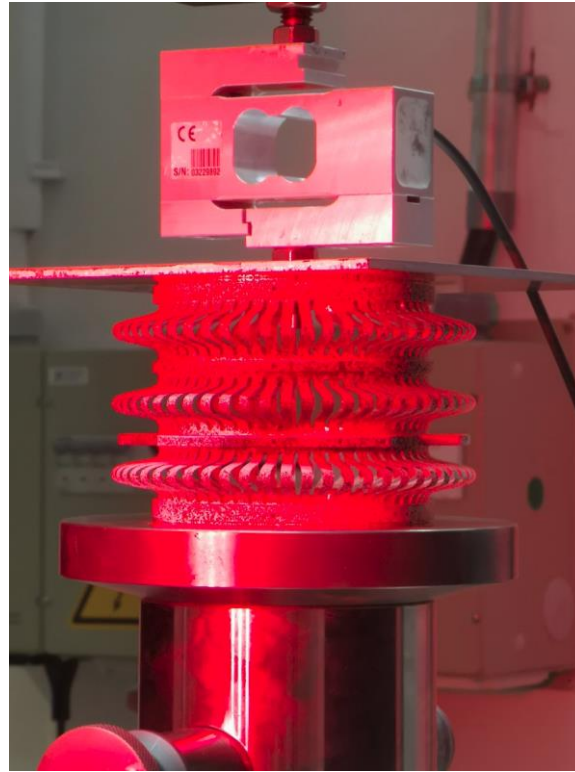

10 N

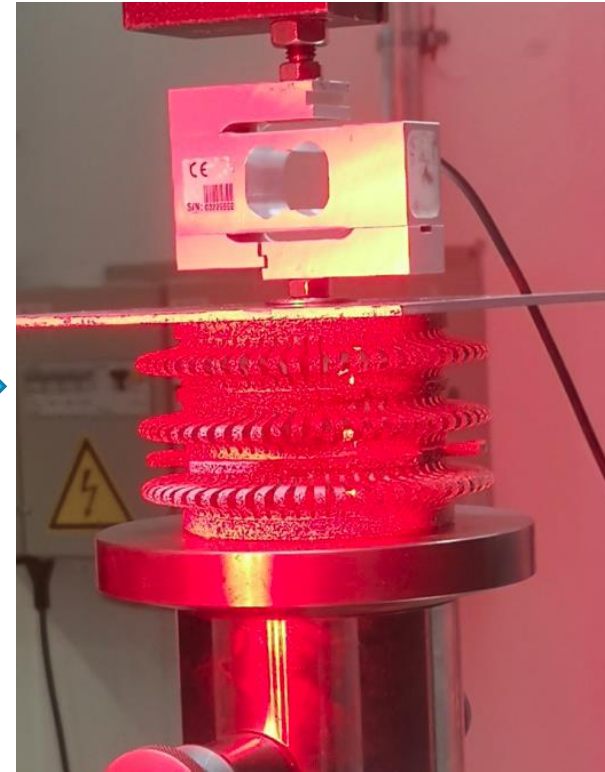

20 N

# Displacement obtained from DIC

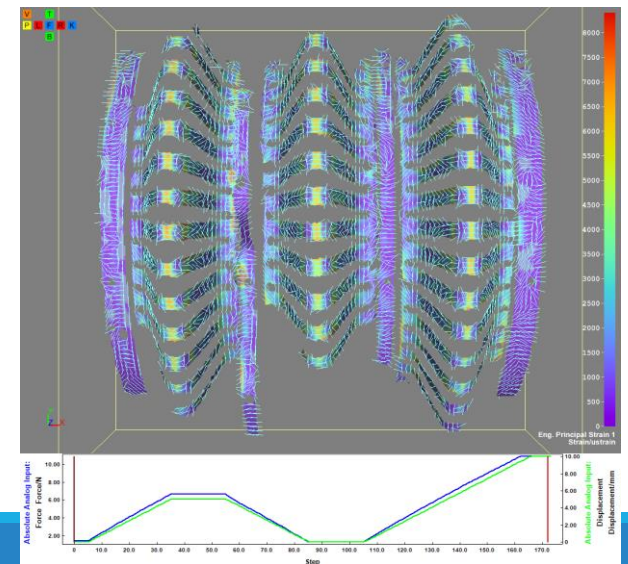
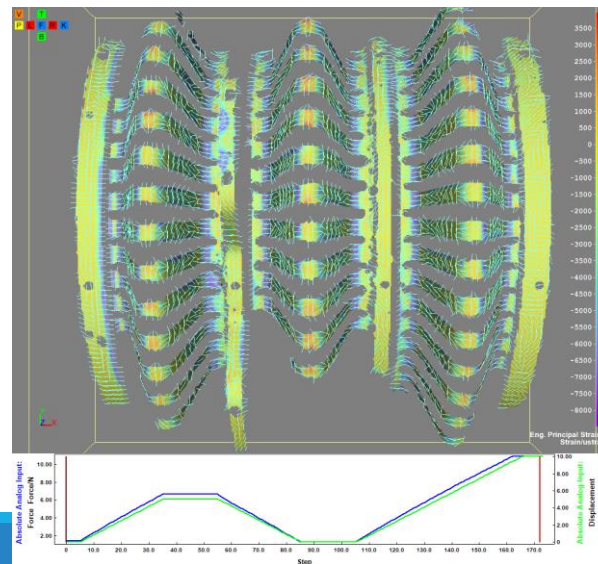
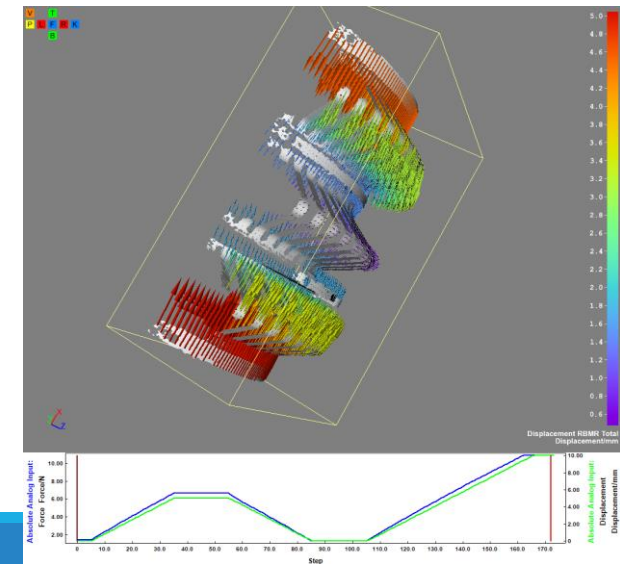
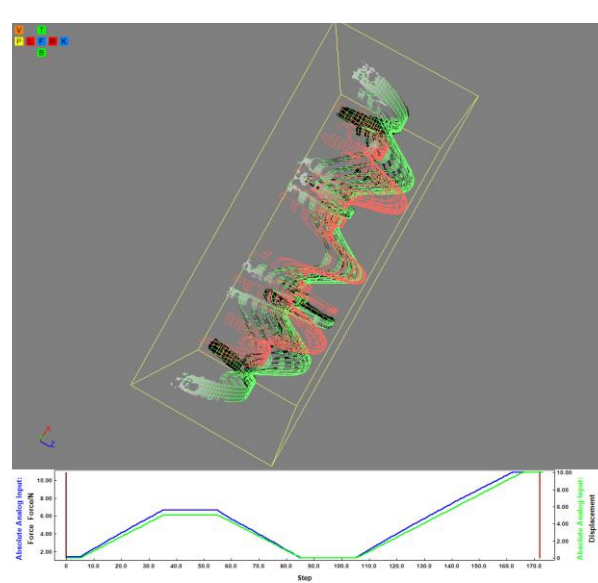
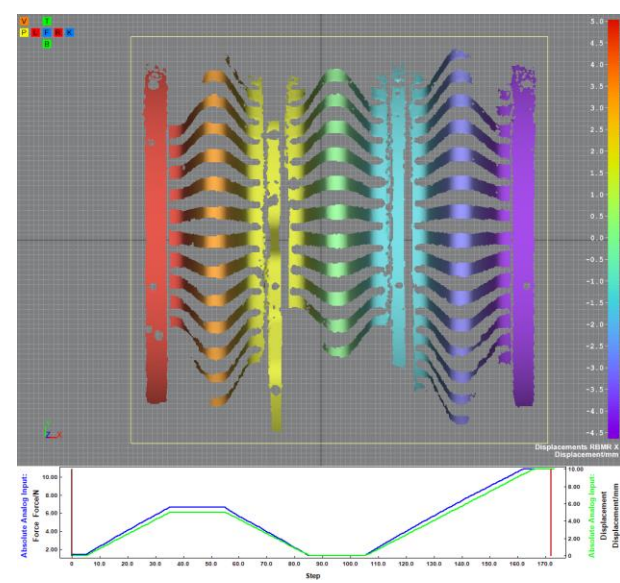

What is this? A city at night?

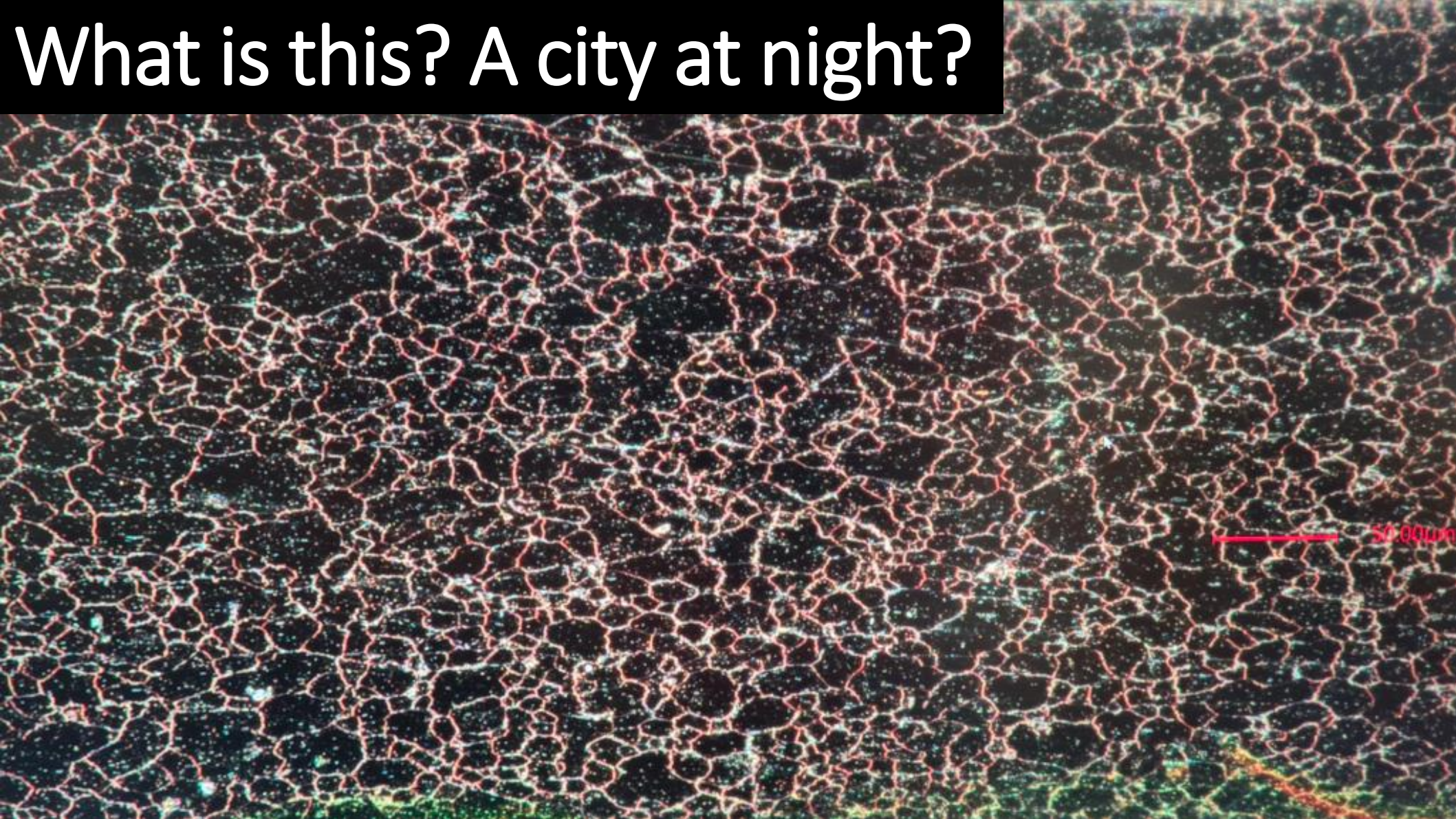

# Bonus: a star on 1 franc coin

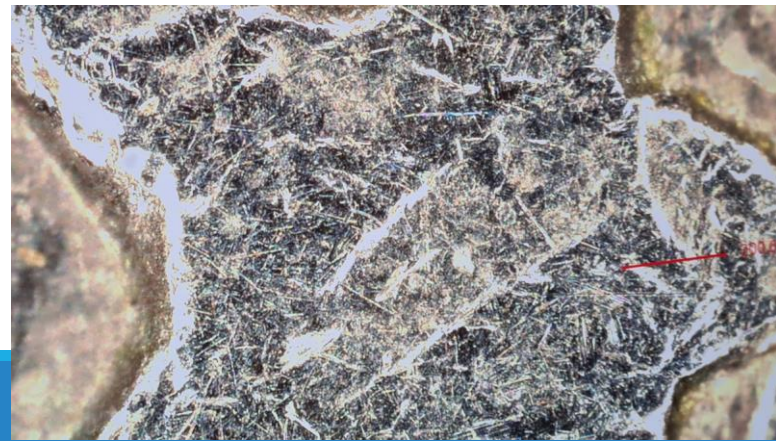
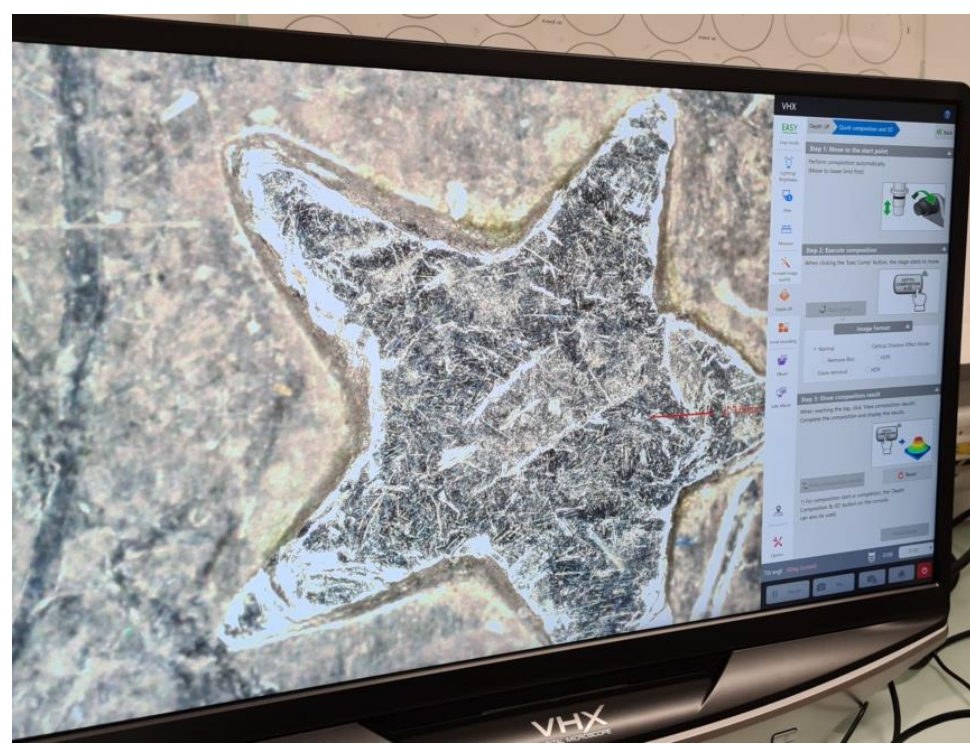
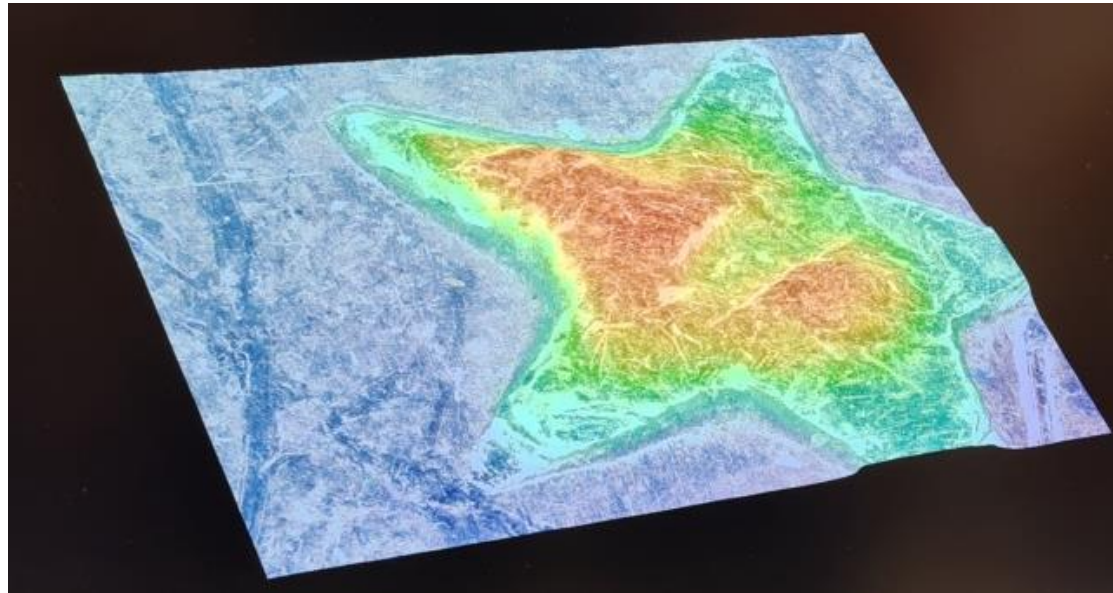

# Scanning the material using an electron microscope and determining the chemical components (Cu, C, O)

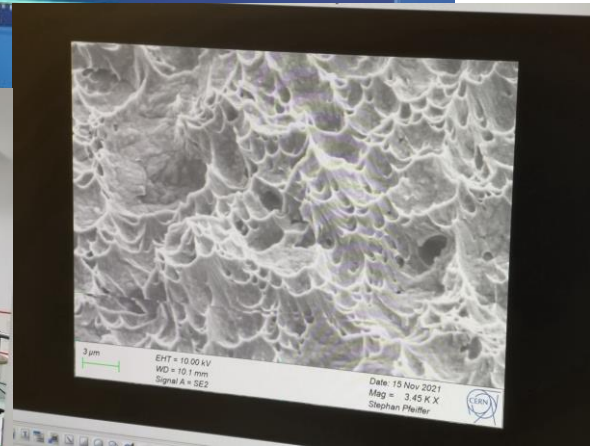
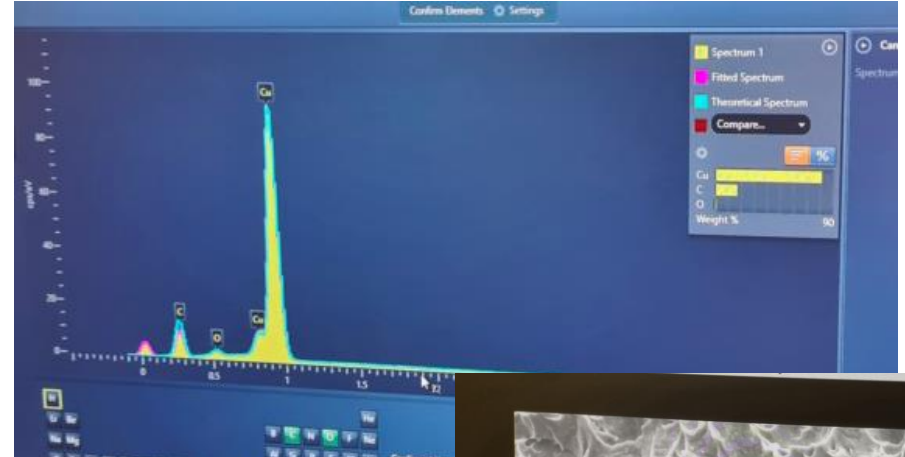

Thank you for  
your attention!

