

Higgs Physics – Lecture 1



Higgs Physics at the LHC – Introduction

Ricardo Gonçalo – LIP

IDPASC Course on Physics at the LHC – LIP, 1 April 2020

Higgs Lectures

18:00 → 19:30 Higgs Physics 1

1h 30m

Introduction

Reminder of some shortcomings of the SM: masses, WW scattering.

The Higgs mechanism. Production and decay of the Higgs boson at colliders: LEP, Tevatron and LHC. Previous searches at LEP and the Tevatron.

Speaker: Ricardo Jose Morais Silva Goncalo (LIP Laboratorio de Instrumentacao e Fisica Experimental de Part)

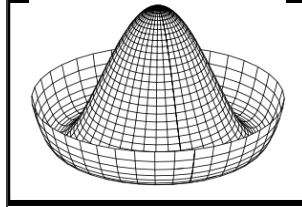

MONDAY, 6 APRIL

18:00 → 19:30 Higgs Physics 2

1h 30m

Models, properties, and interpretation.

Case-study of the coupling strengths.

Case-study of the hypothesis test for different spin-parity assignments.

Speaker: Pedro Vieira De Castro Ferreira Da Silva (CERN)

Combined LHC mass measurement

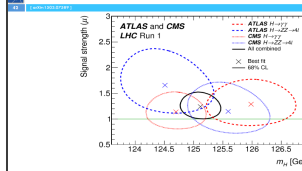

WEDNESDAY, 8 APRIL

18:00 → 19:30 Higgs Physics 3

1h 30m

Discovery of the Higgs boson in the different final states

Case-study of the H->WW search

Algorithms, challenges, tools

Combination of search results

Speaker: Dr Patricia Conde Muino (LIP Laboratorio de Instrumentacao e Fisica Experimental de Part)

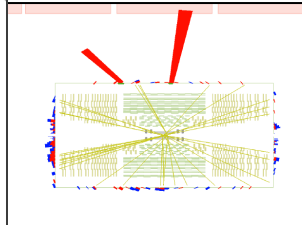

WEDNESDAY, 15 APRIL

18:00 → 19:30 Higgs Physics 4

1h 30m

- Search for new physics in the Higgs sector.
- The Higgs boson and processes beyond the SM.
- Extensions of the SM, minimal and non-minimal extensions.
- High mass searches.
- MSSM Higgs searches: neutral, charged.
- Light pseudoscalar, resonant and non-resonant Higgs pair production.

Speaker: Michele Gallinaro (LIP Lisbon)



Outlook



- Introduction
- Some theory
 - Problems with the Standard Model
- The Higgs mechanism
- The long way to discovery
 - LEP experiments
 - Tevatron experiments
 - Search and Discovery at the LHC
- Higgs boson properties
- Open questions

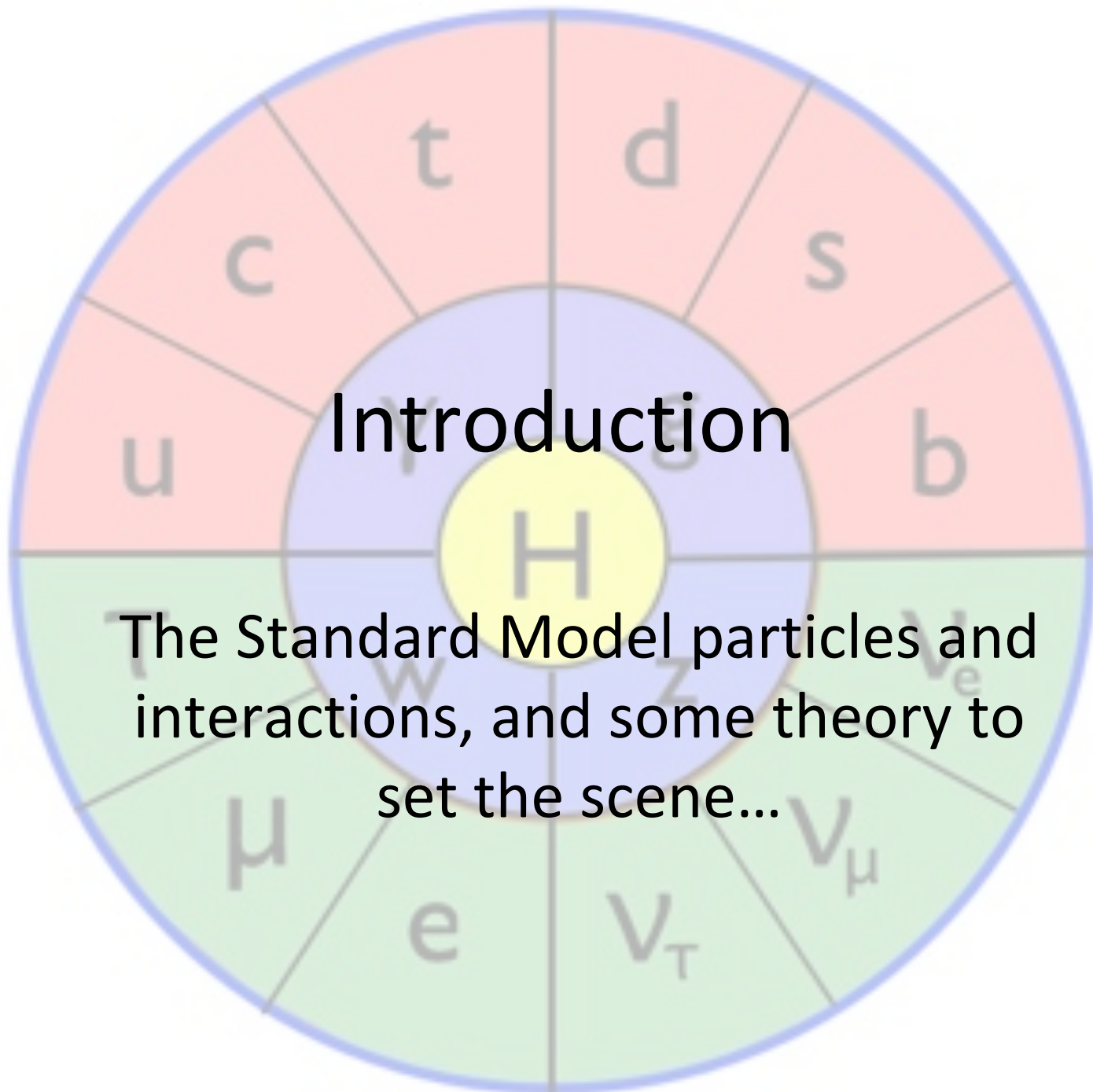

Introduction

The Standard Model particles and interactions, and some theory to set the scene...

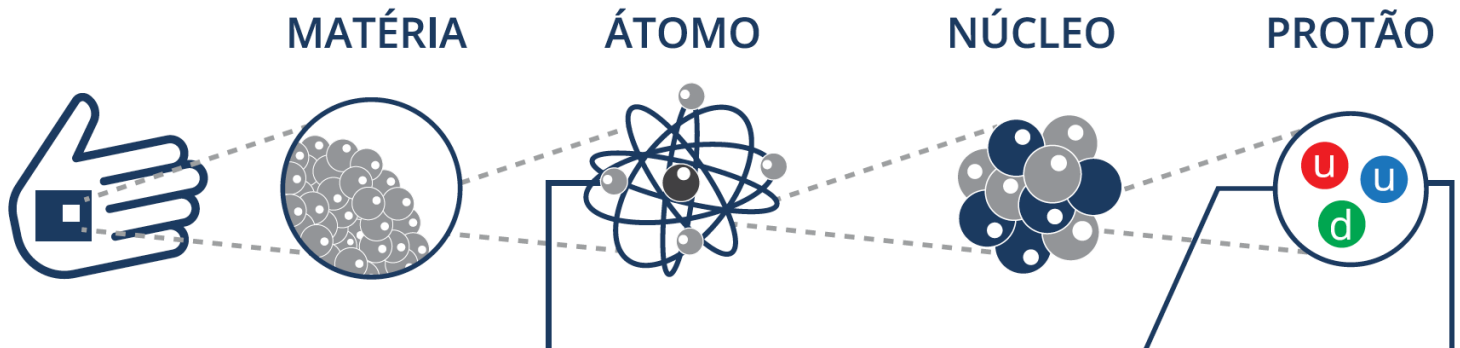

LEPTÕES

ν_e NEUTRINO DO ELETRÃO 0 $\frac{1}{2}$	e ELETRÃO -1 $\frac{1}{2}$
ν_μ NEUTRINO DO MUÃO 0 $\frac{1}{2}$	μ MUÃO -1 $\frac{1}{2}$
ν_τ NEUTRINO DO TAU 0 $\frac{1}{2}$	τ TAU -1 $\frac{1}{2}$

QUARKS

u UP $\frac{2}{3}$ $\frac{1}{2}$	d DOWN $-\frac{1}{3}$ $\frac{1}{2}$
c CHARM $\frac{2}{3}$ $\frac{1}{2}$	s STRANGE $-\frac{1}{3}$ $\frac{1}{2}$
t TOP $\frac{2}{3}$ $\frac{1}{2}$	b BOTTOM $-\frac{1}{3}$ $\frac{1}{2}$

E as forças fundamentais?

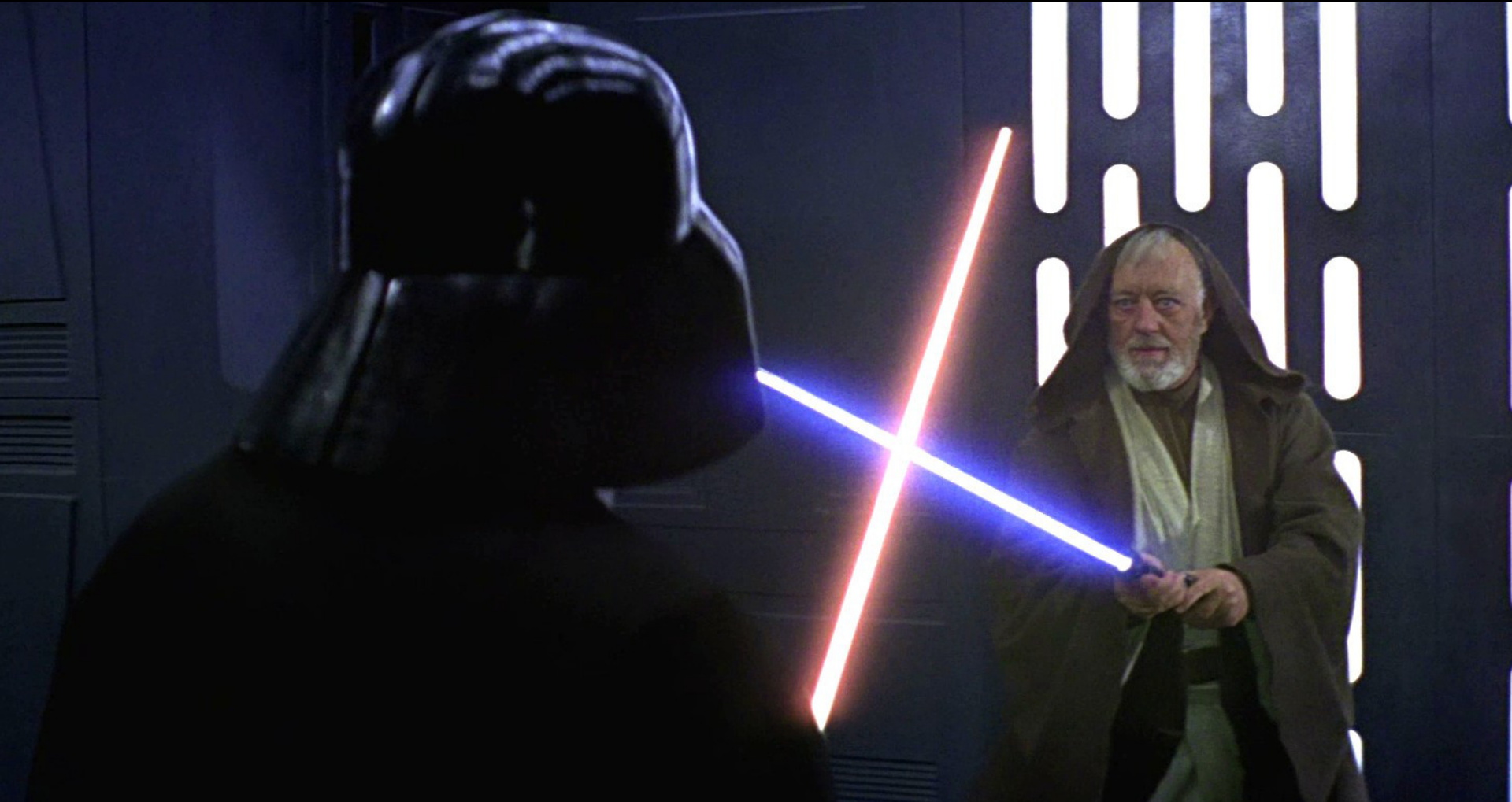

Summary of Standard Model matter vertices

Electromagnetic (QED)

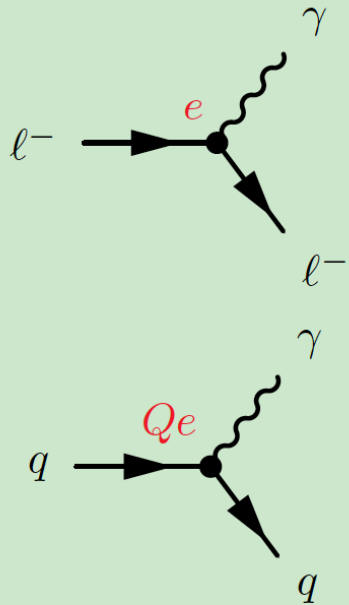

$$\alpha = \frac{e^2}{4\pi}$$

$q = u, d, s, c, b, t$

+ antiparticles

Strong (QCD)

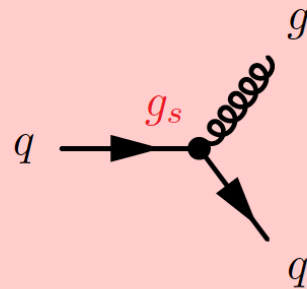

$$\alpha_s = \frac{g_s^2}{4\pi}$$

Weak CC

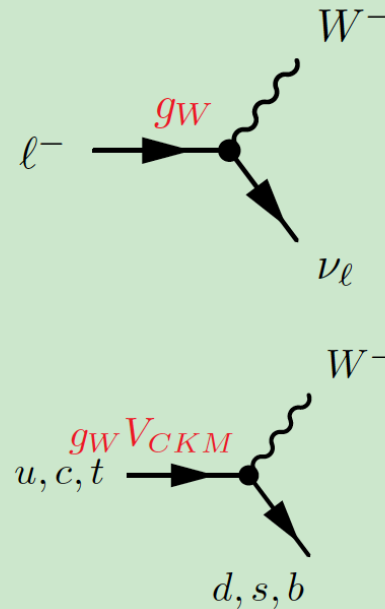

$$\alpha_W = \frac{g_W^2}{4\pi}$$

Weak NC

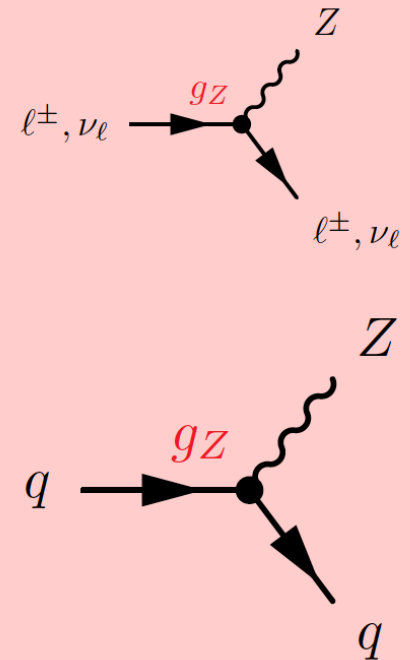

$$g_Z = \frac{g_W}{\cos \theta_W}$$

Electroweak Unification

- Weak CC interactions explained by W^\pm boson exchange
- W^\pm bosons are charged, thus they couple to the γ

Consider $e^-e^+ \rightarrow W^+W^-$: 2 diagrams (+interference)

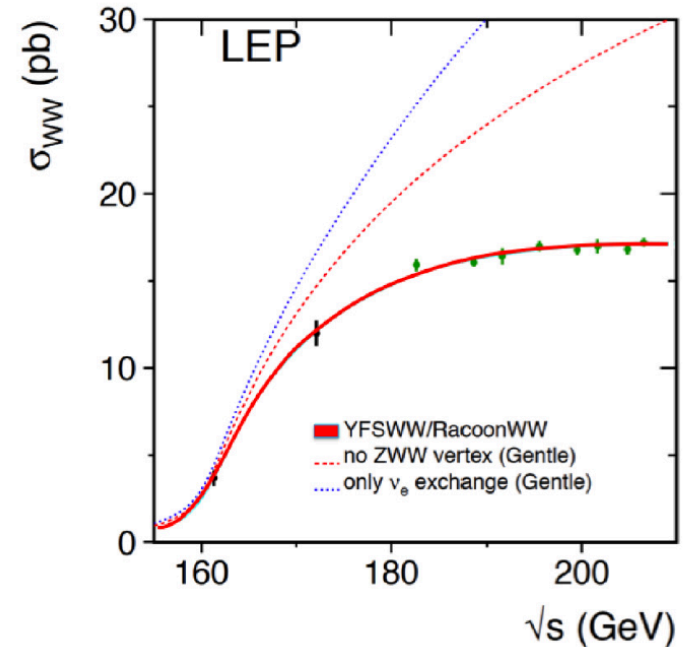
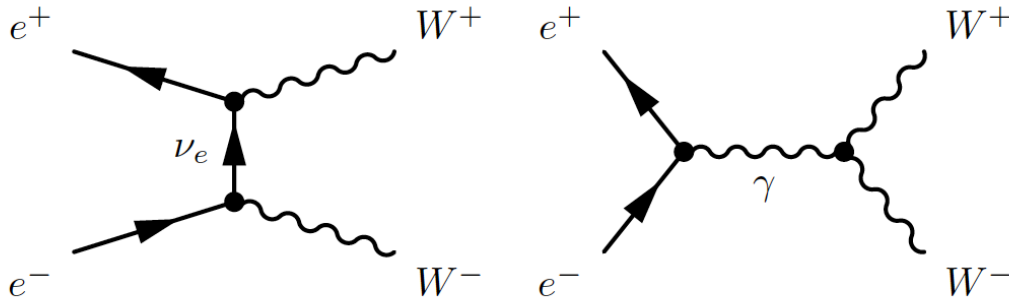

- Cross-section **diverges** at high energy
- Divergence cured by introducing Z boson
- Extra diagram for $e^-e^+ \rightarrow W^+W^-$
- Idea only works if γ , W^\pm , Z couplings are related

\Rightarrow **Electroweak Unification**

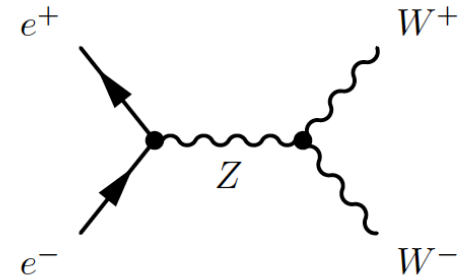

Electroweak Gauge Theory

- Postulate invariance under a gauge transformation like:

$$\psi \rightarrow \psi' = e^{ig\vec{\sigma}\cdot\vec{\Lambda}(\vec{r},t)}\psi$$

an “SU(2)” transformation (σ are 2x2 matrices).

- Operates on the state of “weak isospin” – a “rotation” of the isospin state.
- Invariance under SU(2) transformations \Rightarrow three massless gauge bosons (W_1, W_2, W_3) whose couplings are well specified.
- They also have self-couplings.

But this doesn't quite work...

Predicts W and Z have the same couplings – not seen experimentally!

Electroweak Gauge Theory

The solution...

- Unify QED and the weak force \Rightarrow electroweak model
- “SU(2)xU(1)” transformation
U(1) operates on the “weak hypercharge” $Y = 2(Q - I_3)$
SU(2) operates on the state of “weak isospin, I”
- Invariance under SU(2)xU(1) transformations \Rightarrow four massless gauge bosons W^+, W^-, W_3, B
- The two neutral bosons W_3 and B then **mix** to produce the physical bosons Z and γ
- Photon properties must be the same as QED \Rightarrow predictions of the couplings of the Z in terms of those of the W and γ
- Still need to account for the **masses** of the W and Z . This is the job of the **Higgs mechanism** (later).

The GWS Model



The **G**lashow, **W**einberg and **S**alam model treats **EM** and **weak** interactions as different manifestations of a single **unified electroweak** force (Nobel Prize 1979)

Start with 4 massless bosons W^+ , W_3 , W^- and B . The neutral bosons **mix** to give physical bosons (the particles we see), i.e. the W^\pm , Z , and γ .

$$\begin{pmatrix} W^+ \\ W_3 \\ W^- \end{pmatrix}; B \rightarrow \begin{pmatrix} W^+ \\ Z \\ W^- \end{pmatrix}; \gamma$$

Physical fields: W^+ , Z , W^- and A (photon).

$$Z = W_3 \cos \theta_W - B \sin \theta_W$$

$$A = W_3 \sin \theta_W + B \cos \theta_W$$

θ_W Weak Mixing Angle

W^\pm , Z “acquire” mass via the **Higgs mechanism**.

The GWS Model

The beauty of the **GWS** model is that it makes **exact** predictions of the W^\pm and Z masses and of their couplings with **only 3** free parameters.

Couplings given by α_{EM} and θ_W

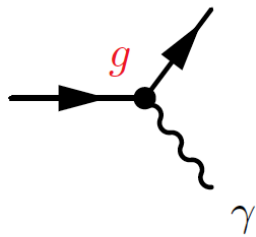

$$\alpha_{EM} = \frac{e^2}{4\pi} \quad g \sim e$$

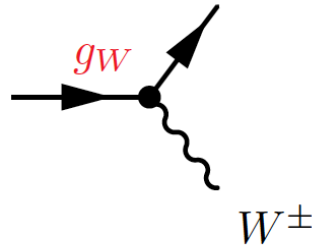

$$g_W = \frac{e}{\sin \theta_W}$$

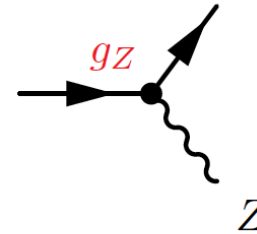

$$g_Z = \frac{e}{\sin \theta_W \cos \theta_W} = \frac{g_W}{\cos \theta_W}$$

Masses also given by G_F and θ_W

From Fermi theory

$$\frac{G_F}{\sqrt{2}} = \frac{g_W^2}{8m_W^2} = \frac{e^2}{8m_W^2 \sin^2 \theta_W} \quad m_{W^\pm} = \left(\frac{\sqrt{2}e^2}{8G_F \sin^2 \theta_W} \right)^{1/2} \quad m_Z = \frac{m_W}{\cos \theta_W}$$

If we know α_{EM} , G_F , $\sin \theta_W$ (from experiment), everything else is defined.

Evidence for the GWS model

- **Discovery of Neutral Currents (1973)**

The process $\bar{\nu}_\mu e^- \rightarrow \bar{\nu}_\mu e^-$ was observed.

Only possible Feynman diagram (no W^\pm diagram).

Indirect evidence for Z .

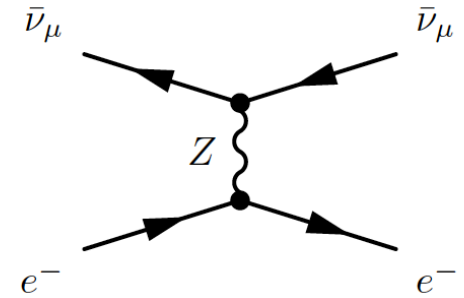

Gargamelle Bubble Chamber at CERN



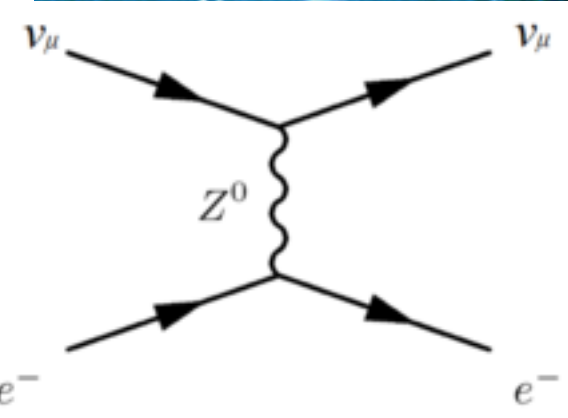
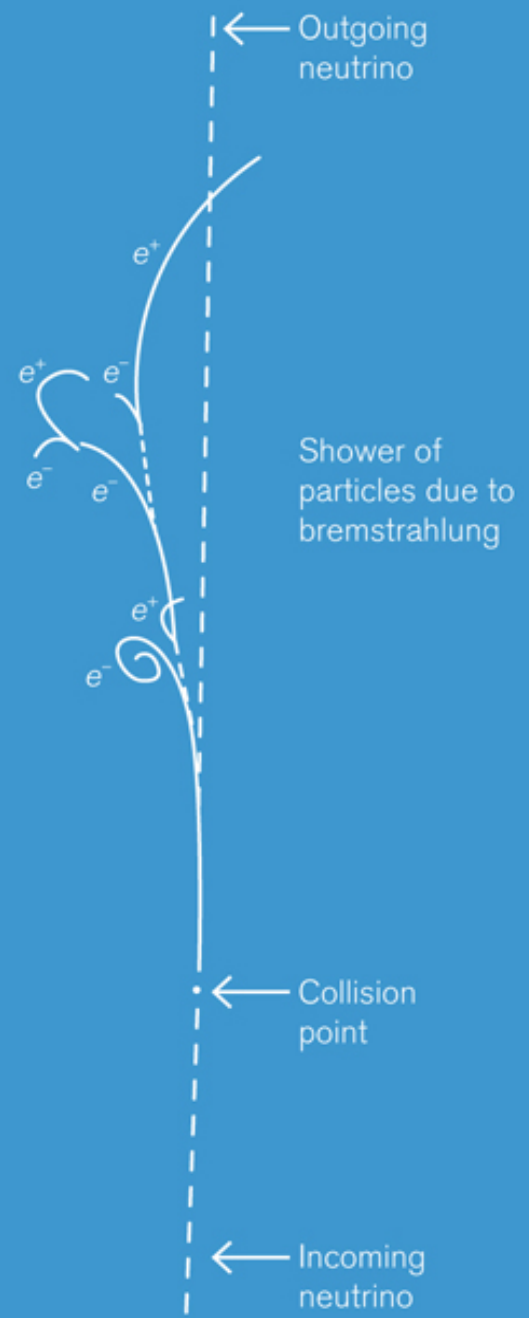
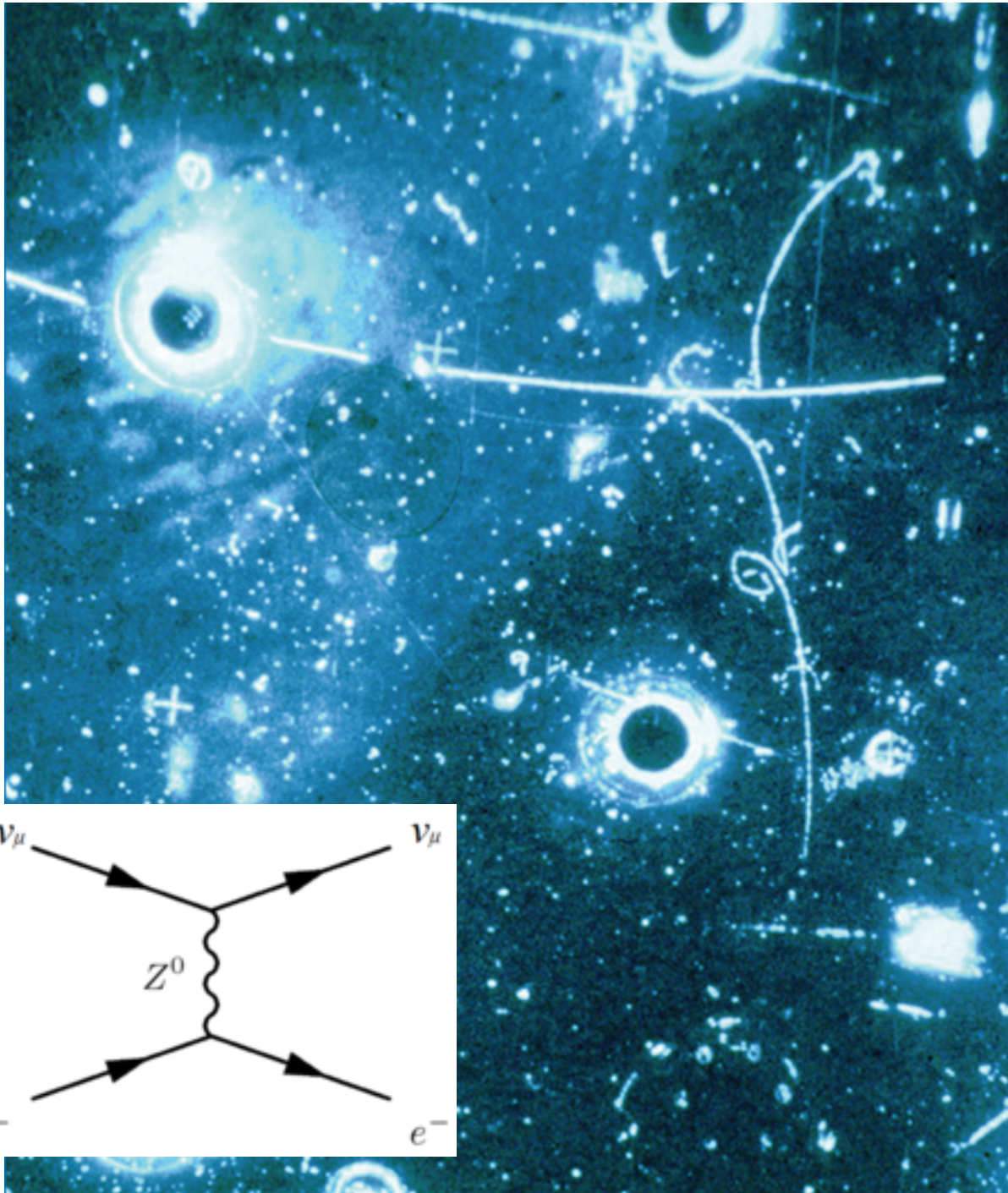

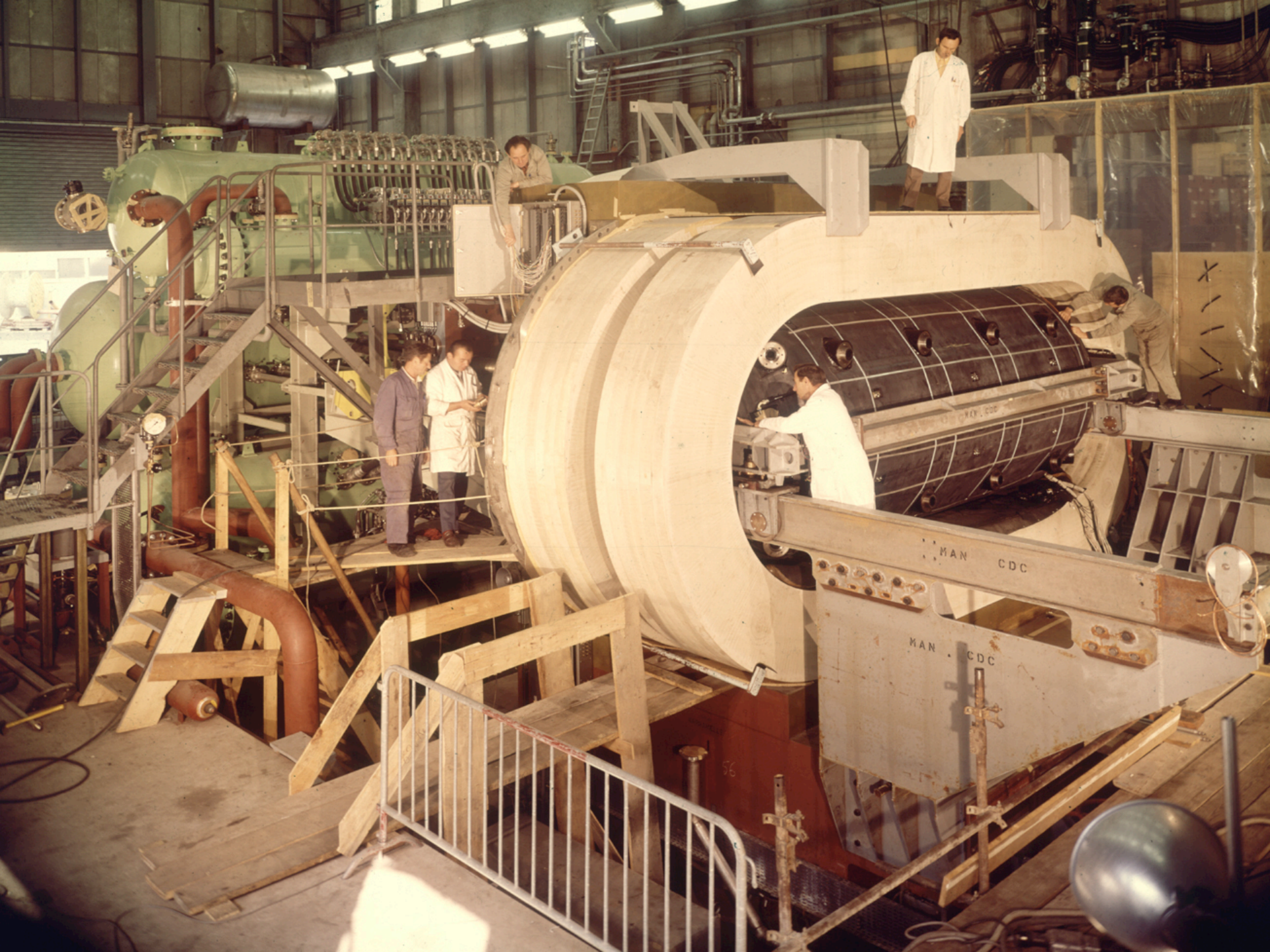

MAN CDC

MAN CDC

MAN CDC

MAN CDC

MAN CDC

MAN CDC

MAN CDC

56

Evidence for the GWS model

- **Discovery of Neutral Currents (1973)**

The process $\bar{\nu}_\mu e^- \rightarrow \bar{\nu}_\mu e^-$ was observed.

Only possible Feynman diagram (no W^\pm diagram).

Indirect evidence for Z .

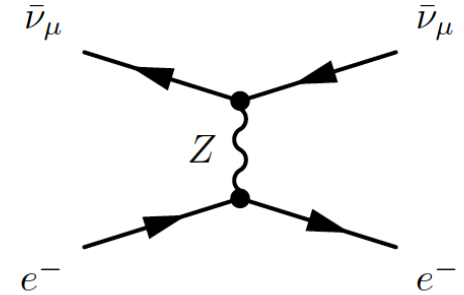

- **Direct Observation of W^\pm and Z (1983)**

First **direct** observation in $p\bar{p}$ collisions at $\sqrt{s} = 540$ GeV via decays into leptons

$$p\bar{p} \rightarrow W^\pm + X$$

$$\hookrightarrow e^\pm \nu_e, \mu^\pm \nu_\mu$$

$$p\bar{p} \rightarrow Z + X$$

$$\hookrightarrow e^+ e^-, \mu^+ \mu^-$$

UA1 Experiment at CERN
Used Super Proton Synchrotron
(now part of LHC!)

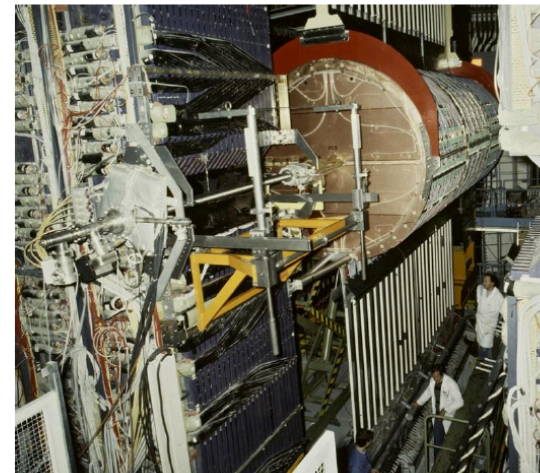



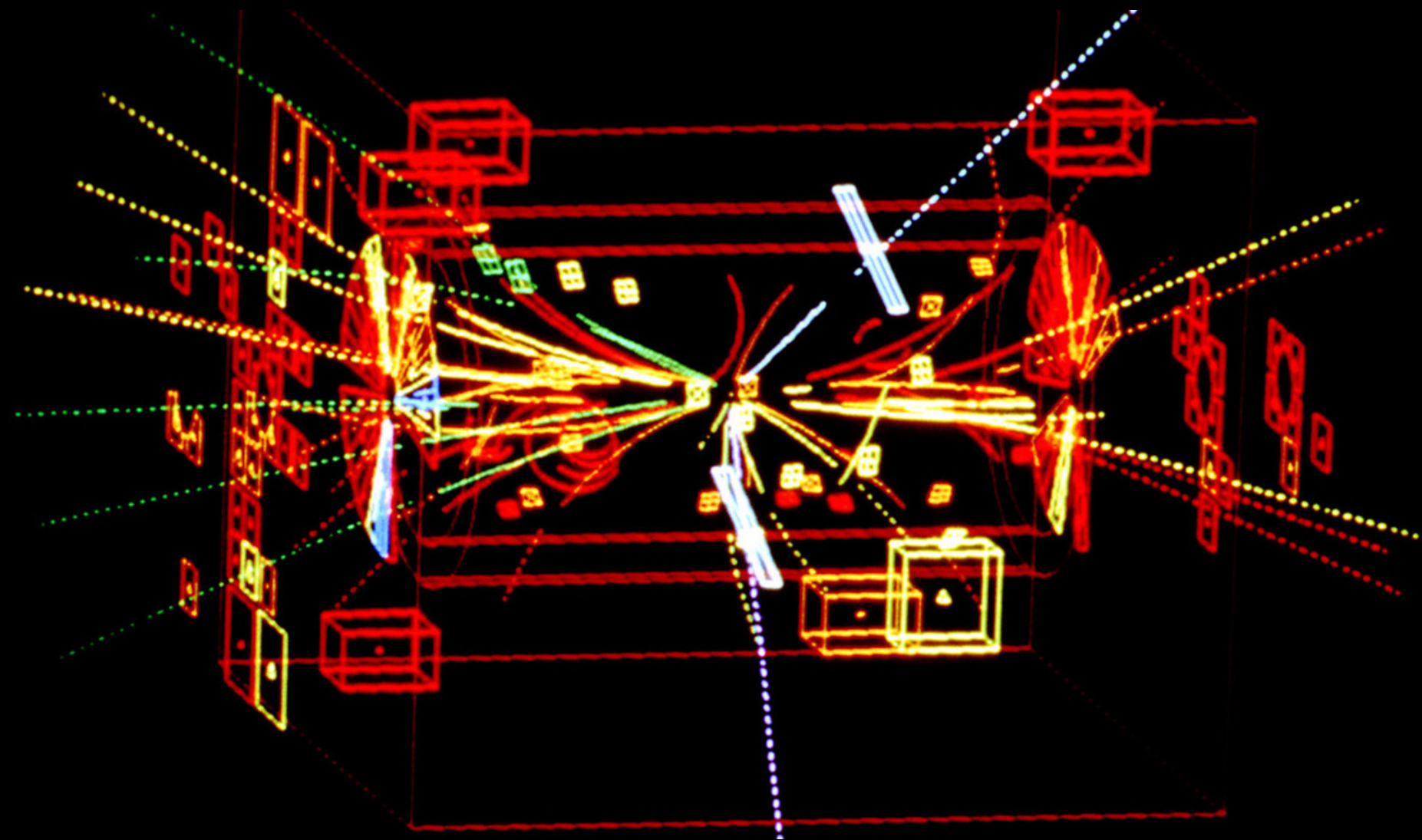

Evidence for the GWS model

- **Discovery of Neutral Currents (1973)**

The process $\bar{\nu}_\mu e^- \rightarrow \bar{\nu}_\mu e^-$ was observed.

Only possible Feynman diagram (no W^\pm diagram).

Indirect evidence for Z .

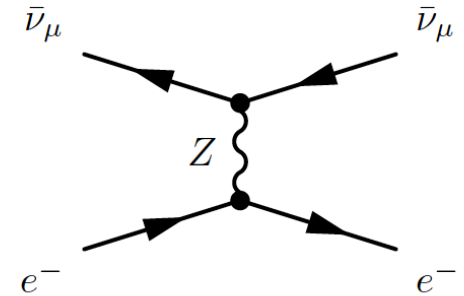

- **Direct Observation of W^\pm and Z (1983)**

First **direct** observation in $p\bar{p}$ collisions at $\sqrt{s} = 540$ GeV via decays into leptons

$$\begin{aligned}
 p\bar{p} &\rightarrow W^\pm + X & p\bar{p} &\rightarrow Z + X \\
 &\hookrightarrow e^\pm \nu_e, \mu^\pm \nu_\mu & &\hookrightarrow e^+ e^-, \mu^+ \mu^-
 \end{aligned}$$

- **Precision Measurements of the Standard Model (1989-2000)**

LEP e^+e^- collider provided many precision measurements of the Standard Model.

- Wide variety of different processes consistent with GWS model predictions and measure **same value** of

$$\sin^2 \theta_W = 0.23113 \pm 0.00015$$

$$\theta_W \sim 29^\circ$$

Experimental tests of the Electroweak model at LEP

The **L**arge **E**lectron **P**ositron (LEP) collider at CERN provided high precision measurements of the Standard Model (1989-2000).

Designed as a Z and W^\pm boson factory

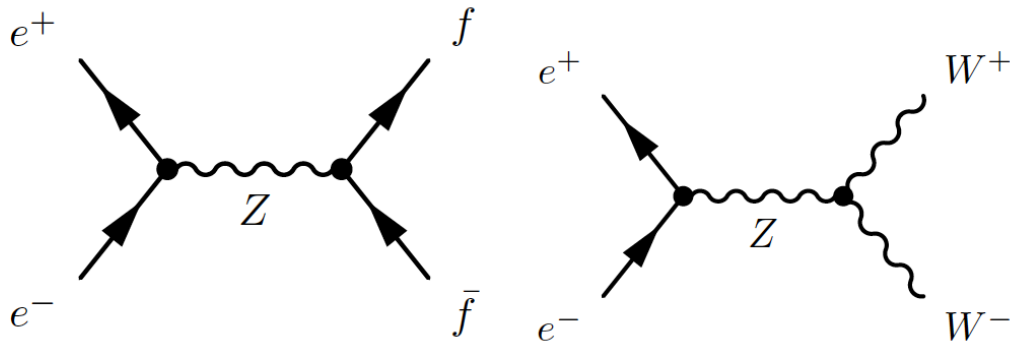

Precise measurements of the properties of Z and W^\pm bosons provide the most stringent test of our current understanding of particle physics.

- LEP is the highest energy e^+e^- collider ever built $\sqrt{s} = 90 - 209$ GeV
- Large circumference, 27 km
- 4 experiments combined saw 16×10^6 Z events, 30×10^3 W^\pm events

Summary of Electroweak tests

Now have **5** precise measurements of fundamental parameters of the Standard Model

$$\alpha_{EM} = 1/(137.03599976 \pm 0.00000050) \quad (\text{at } q^2 = 0)$$

$$G_F = (1.16632 \pm 0.00002) \times 10^5 \text{ GeV}^{-2}$$

$$m_W = 80.385 \pm 0.015 \text{ GeV}$$

$$m_Z = 91.1875 \pm 0.0021 \text{ GeV}$$

$$\sin^2 \theta_W = 0.23143 \pm 0.00015$$

In the Standard Model, **only 3** are independent.

The measurements are consistent, which is an incredibly powerful test of the Standard Model of Electroweak Interactions.

ZEUS

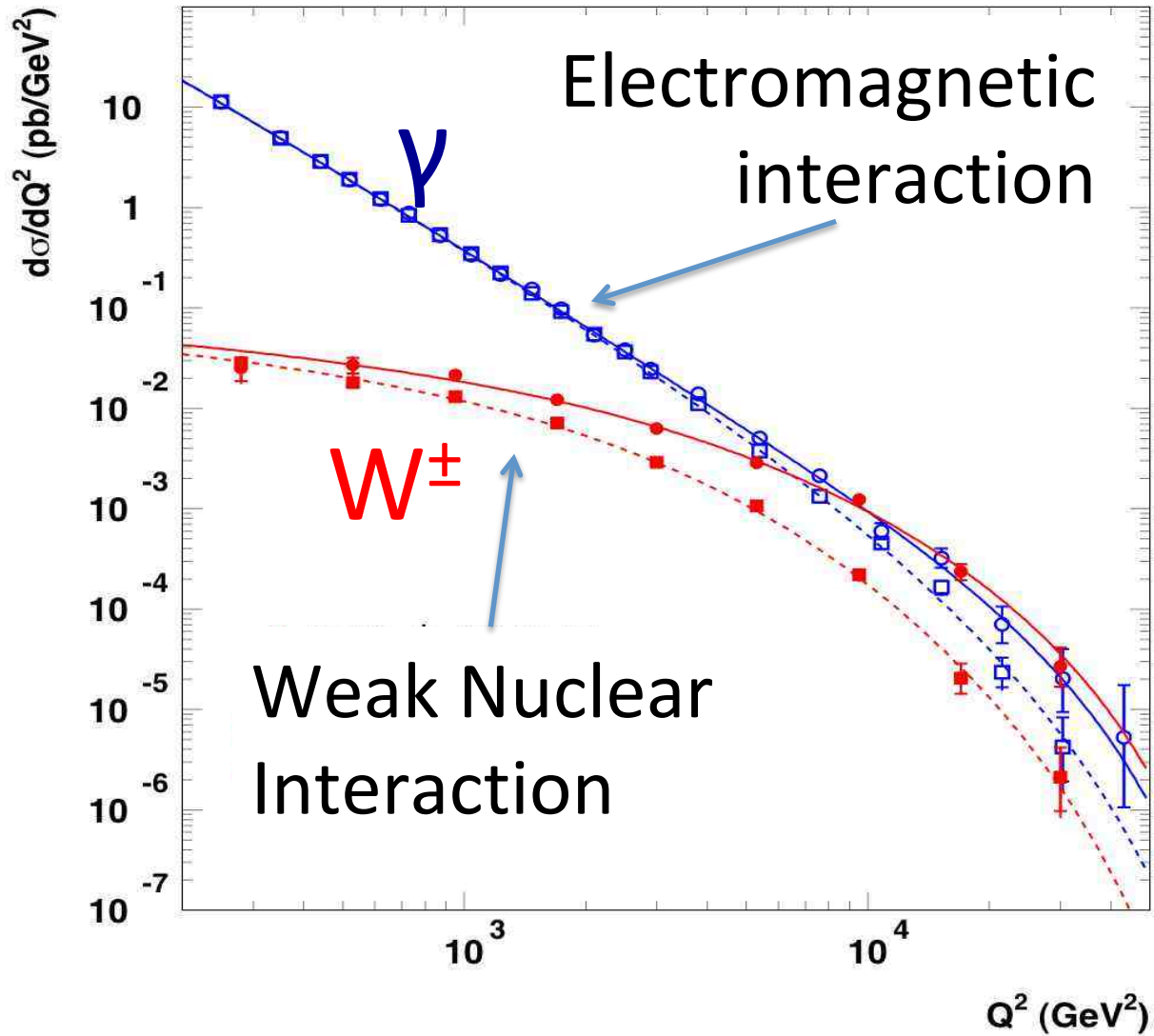

Standard Model Production Cross Section Measurements

Status: July 2018

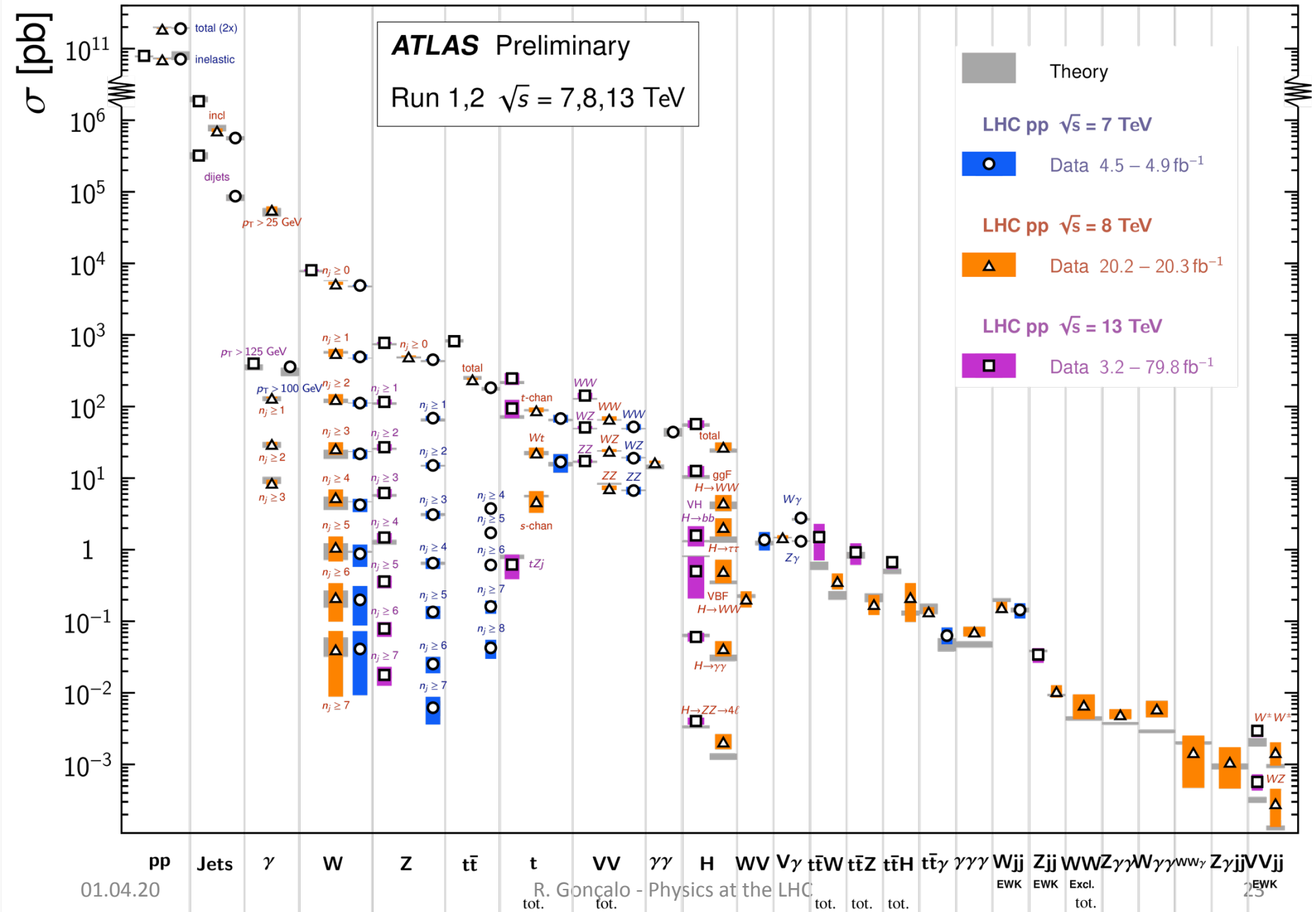

Now for the problems...



Gauge invariance

Take the Dirac Lagrangian for a spinor field ψ representing a spin- $\frac{1}{2}$ particle, for example an electron:

$$\mathcal{L} = i\hbar\bar{\psi}\gamma^\mu\partial_\mu\psi - m\bar{\psi}\psi$$

It is invariant under a global U(1) phase transformation like:

$$\psi(x) \rightarrow \psi'(x) = e^{iq\chi}\psi(x)$$

Where χ is a constant

$$\mathcal{L}' = e^{-iq\chi}e^{iq\chi}(i\hbar\bar{\psi}\gamma^\mu\partial_\mu\psi - m\bar{\psi}\psi) = \mathcal{L}$$

$$\psi(x) \rightarrow \psi'(x) = e^{iq\chi} \psi(x)$$

Original sphere

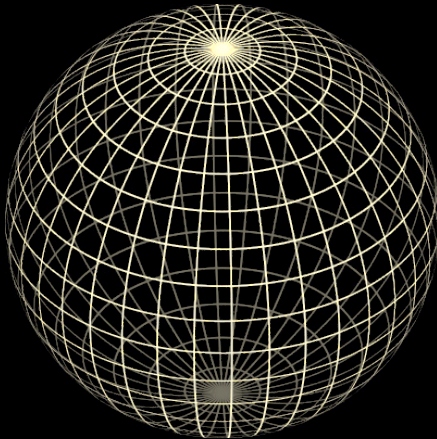

Global transformation

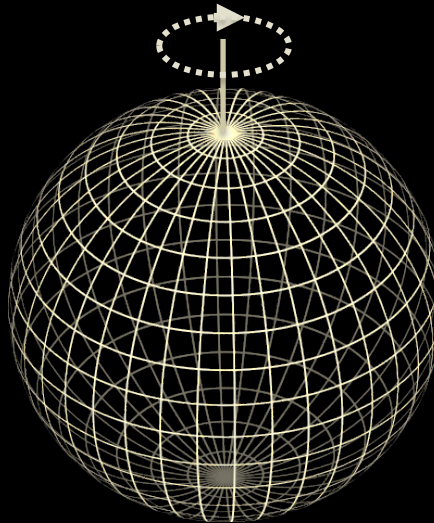

$$\chi = \text{constant}$$

Local transformação

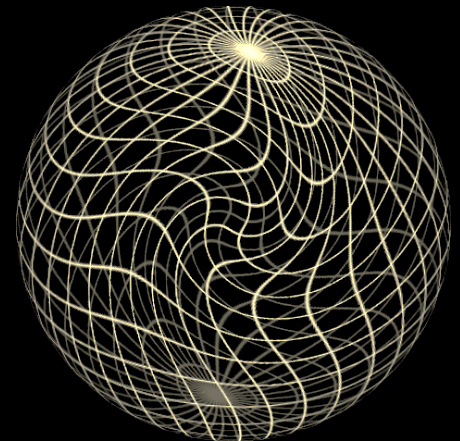

$$\chi = \chi(x)$$

Local gauge invariance and interactions

If $\chi = \chi(x)$ then we get extra terms in the Lagrangian:

$$\begin{aligned}\mathcal{L}' &= ie^{-iq\chi}\bar{\psi}\gamma^\mu[e^{iq\chi}\partial_\mu\psi + iq(\partial_\mu\chi)e^{iq\chi}\psi] - me^{-iq\chi}e^{iq\chi}\bar{\psi}\psi \\ &= \mathcal{L}' - q\bar{\psi}\gamma^\mu(\partial_\mu\chi)\psi\end{aligned}$$

But we can now make the Lagrangian invariant by adding an **interaction term** with a new **gauge field** \mathbf{A}_μ which transforms as:

$$A_\mu \rightarrow A'_\mu = A_\mu - \partial_\mu\chi$$

We get:

$$\mathcal{L} = i\bar{\psi}\gamma^\mu\partial_\mu\psi - m\bar{\psi}\psi - q\bar{\psi}\gamma^\mu A_\mu\psi$$

A few things to note:

1. Gauge theories are renormalizable, i.e. calculable without infinities popping up everywhere (Nobel prize of t'Hooft and Veltman)
2. The new gauge field \mathbf{A}_μ is the photon in QED
3. The mass of the fermion is the coefficient of the term on $\bar{\psi}\psi$
4. There is no term in $\mathbf{A}_\mu\mathbf{A}^\mu$ (the photon has zero mass) \rightarrow this is the beginning of the Higgs story...

Problem 1: Mass of elementary particles and gauge bosons

$$\mathcal{L}_{QED} = \bar{\psi}(i\gamma^\mu \partial_\mu - m_e)\psi - e\bar{\psi}\gamma^\mu\psi A_\mu - \frac{1}{4}F_{\mu\nu}F^{\mu\nu} + \frac{1}{2}m_\gamma A_\mu A^\mu$$

To keep the Lagrangian gauge invariant (against a U(1) local phase transformation) the photon field transforms as:

$$A_\mu \rightarrow A'_\mu = A_\mu - \partial_\mu \chi$$

But the \mathbf{A}^μ mass term breaks the invariance of the Lagrangian:

$$\frac{1}{2}m_\gamma A_\mu A^\mu \rightarrow \frac{1}{2}m_\gamma (A_\mu - \partial_\mu \chi)(A^\mu - \partial^\mu \chi) \neq \frac{1}{2}m_\gamma A_\mu A^\mu$$

For the $SU(2)_L$ gauge symmetry transformations of the **weak interaction** the fermion mass term $\mathbf{m}_e \bar{\psi}\psi$ also breaks invariance!

It should not work...

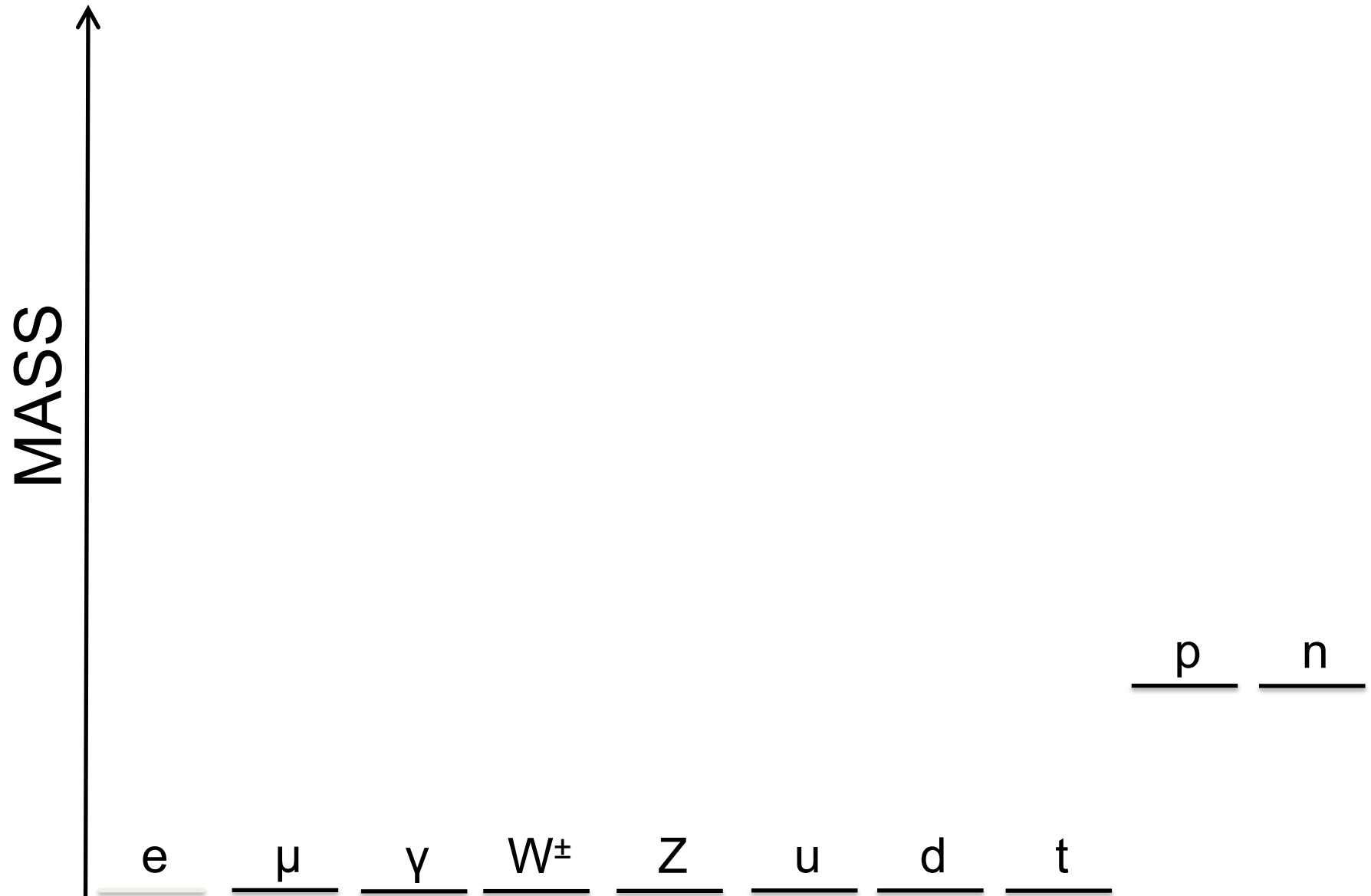

Problem 2:

Longitudinal gauge-boson scattering

In the absence of the Higgs, some processes have cross sections that grow with the centre of mass energy of the collision... i.e. breaks unitarity!

The Higgs regulates the cross section through negative interference

Bottom line: the SM (without the Higgs mechanism) results in wrong calculations and breaks down for massive particles

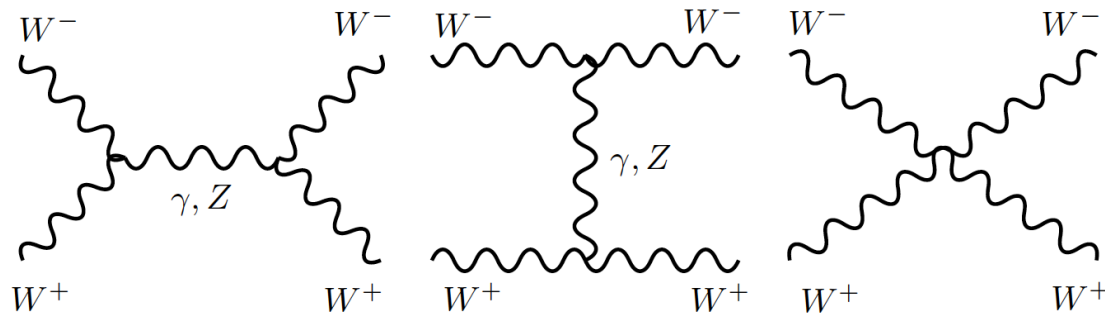
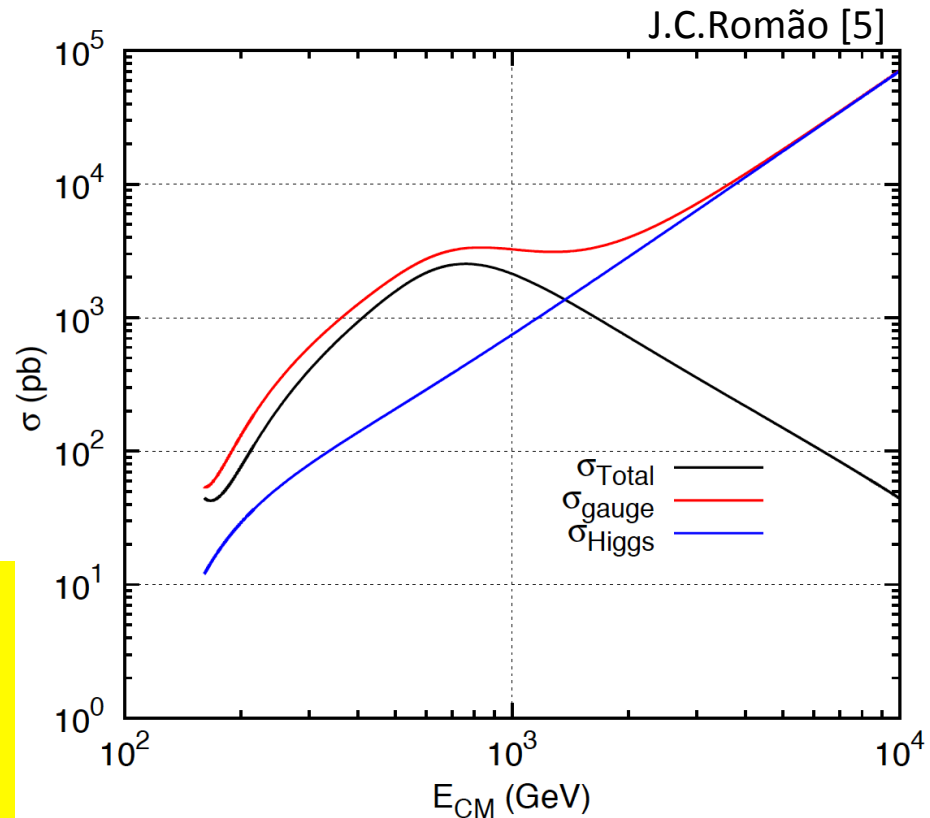

Feynman diagrams contributing to longitudinal WW scattering

The Higgs Mechanism



Robert Brout (1928 – 2011)

Peter Higgs (b. 1929)

François Englert
(b. 1932)



- Introduce a SU(2) doublet of spin-0 complex fields

$$\phi = \begin{pmatrix} \phi^+ \\ \phi^0 \end{pmatrix} = \frac{1}{\sqrt{2}} \begin{pmatrix} \phi_1 + i\phi_2 \\ \phi_3 + i\phi_4 \end{pmatrix}$$

- The Lagrangian is

$$\mathcal{L} = (\partial_\mu \phi)^\dagger (\partial^\mu \phi) - V(\phi)$$

- With a potential

$$V(\phi) = \mu^2 \phi^\dagger \phi + \lambda (\phi^\dagger \phi)^2$$

- For $\lambda > 0, \mu^2 < 0$ the potential has a minimum at the origin
- For $\lambda > 0, \mu^2 > 0$ the potential has an infinite number of minima at:

$$|\phi| = \frac{v}{\sqrt{2}} = \sqrt{-\frac{\mu^2}{2\lambda}}$$

The choice of vacuum (lowest energy state of the field) breaks the symmetry of the Lagrangian

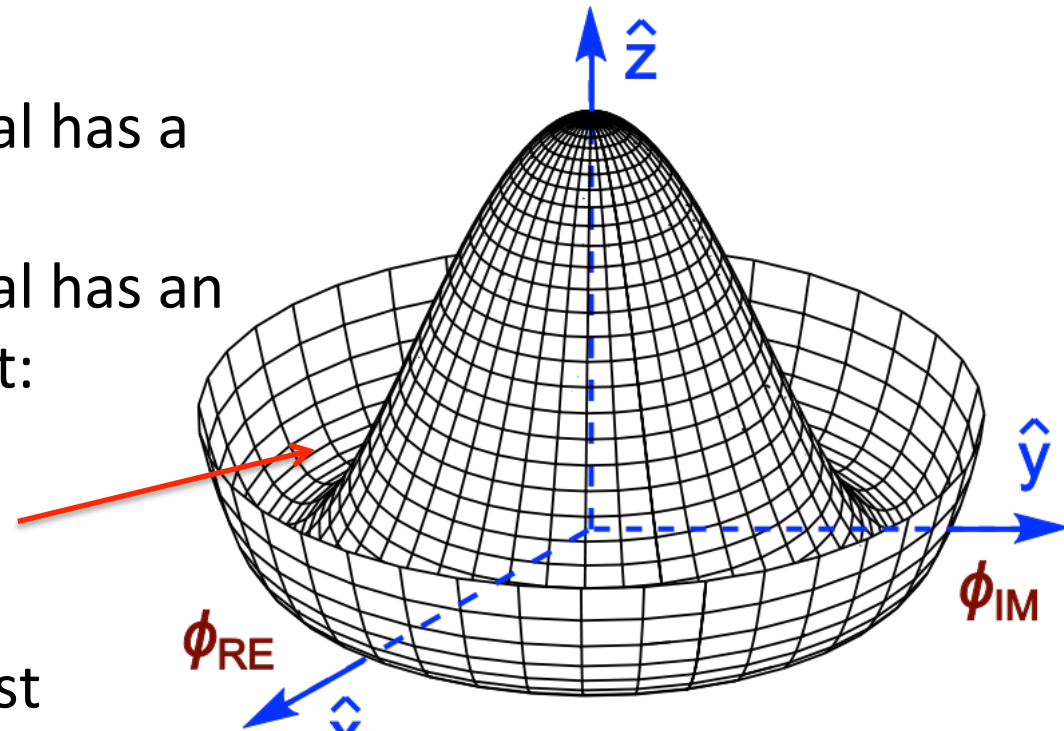

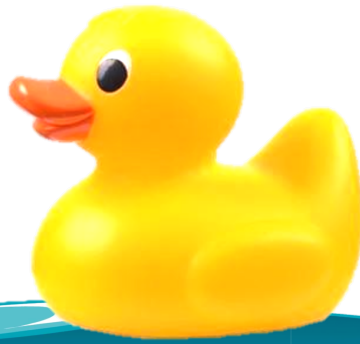

$$V(\phi) = \mu^2 \phi^\dagger \phi + \lambda (\phi^\dagger \phi)^2$$

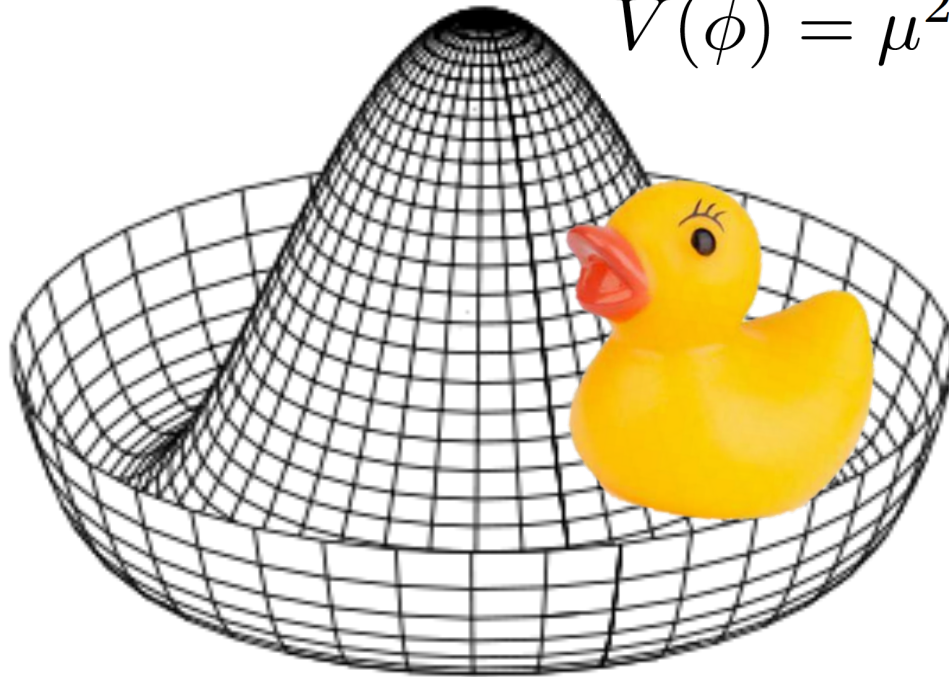

EWK Symmetry Breaking in Pictures

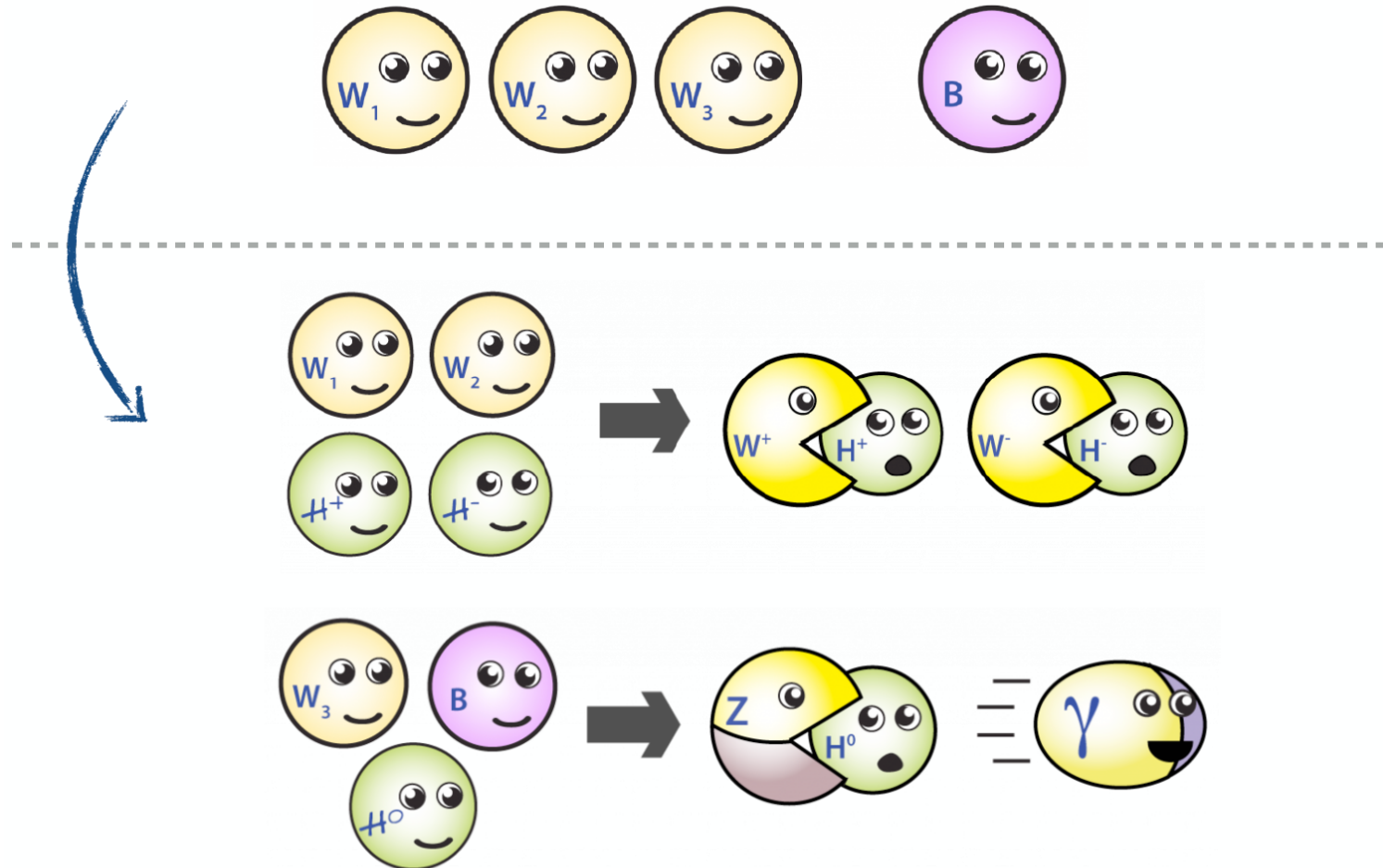

The Story So Far...

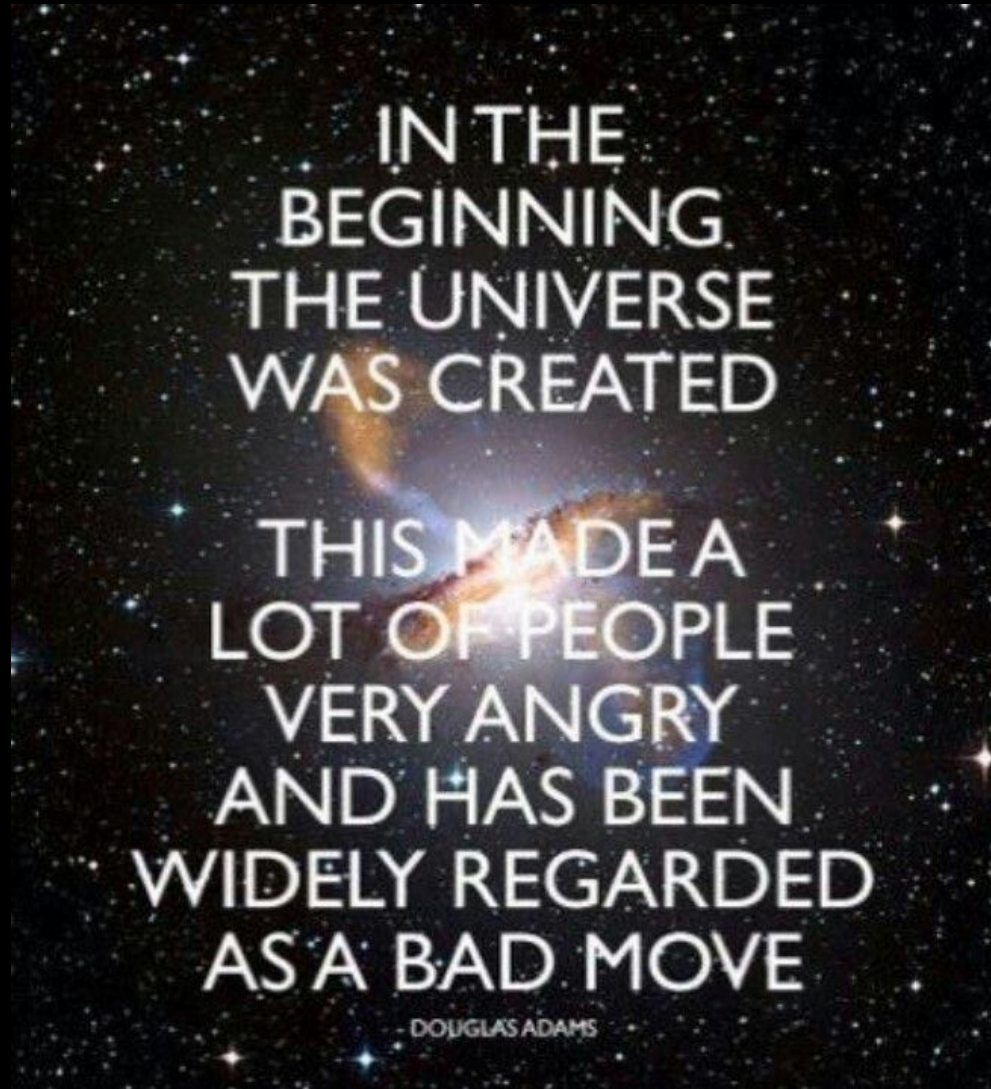

The Standard Model of particle physics

$$\mathcal{L}_{SM} = -\frac{1}{2}\partial_\nu g_\mu^a \partial_\nu g_\mu^a - g_s f^{abc} \partial_\mu g_\nu^a g_\mu^b g_\nu^c - \frac{1}{4}g_s^2 f^{abc} f^{ade} g_\mu^a g_\nu^b g_\mu^c g_\nu^d - \partial_\nu W_\mu^+ \partial_\nu W_\mu^- - M^2 W_\mu^+ W_\mu^- - \frac{1}{2}\partial_\nu Z_\mu^0 \partial_\nu Z_\mu^0 - \frac{1}{2}\partial_\mu A_\nu \partial_\mu A_\nu - ig_{cw} (\partial_\nu Z_\mu^0 (W_\mu^+ W_\nu^- - W_\nu^+ W_\mu^-) + Z_\mu^0 (W_\nu^+ \partial_\mu W_\nu^- - W_\nu^+ \partial_\mu W_\mu^+)) - ig_{sw} (\partial_\nu A_\mu (W_\mu^+ W_\nu^- - W_\nu^+ W_\mu^-) - A_\nu (W_\mu^+ \partial_\nu W_\mu^- - W_\nu^+ \partial_\nu W_\mu^+)) + A_\mu (W_\nu^+ \partial_\nu W_\mu^- - W_\nu^- \partial_\nu W_\mu^+) - \frac{1}{2}g^2 W_\mu^+ W_\nu^- W_\nu^+ W_\mu^- + \frac{1}{2}g^2 W_\mu^+ W_\nu^- W_\nu^+ W_\mu^- + g^2 c_w^2 (Z_\mu^0 W_\nu^+ Z_\nu^0 W_\mu^- - Z_\mu^0 Z_\nu^0 W_\nu^+ W_\mu^-) + g^2 s_w^2 (A_\mu W_\nu^+ A_\nu W_\mu^- - A_\mu A_\nu W_\nu^+ W_\mu^-) + g^2 s_w c_w (A_\mu Z_\nu^0 (W_\mu^+ W_\nu^- - W_\nu^+ W_\mu^-) - 2A_\mu Z_\mu^0 W_\nu^+ W_\nu^-) - \frac{1}{2}\partial_\mu H \partial_\mu H - 2M^2 \alpha_h H^2 - \partial_\mu \phi^+ \partial_\mu \phi^- - \frac{1}{2}\partial_\mu \phi^0 \partial_\mu \phi^0 - \beta_h \left(\frac{2M^2}{g^2} + \frac{2M}{g} H + \frac{1}{2}(H^2 + \phi^0 \phi^0 + 2\phi^+ \phi^-) \right) + \frac{2M^2}{g^2} \alpha_h - \frac{1}{8}g^2 \alpha_h (H^4 + (\phi^0)^4 + 2(\phi^0)^2 H^2) - \frac{1}{2}ig (W_\mu^+ H \partial_\mu \phi^- - \phi^- \partial_\mu W_\mu^+) + ig s_w M A_\mu (W_\mu^+ \phi^- - \phi^- \partial_\mu \phi^+) - \frac{1}{4}g^2 (H^2 + (\phi^0)^2 + 2\phi^+ \phi^-) - \frac{1}{2}g^2 s_w A_\mu \phi^0 (W_\mu^+ \phi^- + Z_\mu^0 A_\mu \phi^+ \phi^-) + m_\nu^2 \bar{\nu}_i \nu_j - \bar{u}_j (\gamma^\mu \partial_\mu + \frac{1}{2}(d_j^2 \gamma^\mu d_j^2)) + s_w^2 (1 - \gamma^5) d_j^2 + (u_j^\dagger \gamma^\mu (1 + \gamma^5) C_{\lambda\kappa} d_j^2) + \bar{\nu}_i (\gamma^\mu \partial_\mu + \gamma^5) e^i + \frac{q}{2M} H (\bar{\nu}_i \nu_i) - \frac{q}{2M} H (\bar{\nu}_i \nu_i) - \frac{q}{2M} H (\bar{e}^i e^i) + \frac{q}{2M} H (\bar{e}^i e^i) + m_\lambda^2 (\bar{\nu}_i \nu_i) + m_\lambda^2 (\bar{e}^i e^i) + m_\lambda^2 (\bar{u}_j^i \gamma^5 u_j^i) - \frac{ig}{2M} H (\bar{d}_j^i d_j^i) + G^a \partial^2 G^a + g_s f^{abc} \partial_\mu \bar{G}^a G_\mu^b g_\mu^c + \partial_\mu \bar{X}^+ X^0 + ig_{sw} W_\mu^+ (\partial_\mu \bar{X}^+ X^- - \partial_\mu \bar{X}^+ X^+) + ig_{sw} W_\mu^- (\partial_\mu \bar{X}^- X^+ - \partial_\mu \bar{X}^- X^0) + ig_{cw} Z_\mu^0 (\partial_\mu \bar{X}^+ X^+ - \partial_\mu \bar{X}^- X^-) + ig_{sw} A_\mu (\partial_\mu \bar{X}^+ X^+ - \partial_\mu \bar{X}^- X^-) - \frac{1}{2}gM (\bar{X}^+ X^+ H + \bar{X}^- X^- H + \frac{1}{c_w} \bar{X}^0 X^0 H) + \frac{1-2c_w^2}{2c_w} igM (\bar{X}^+ X^0 \phi^+ - \bar{X}^- X^0 \phi^-) + \frac{1}{2c_w} igM (\bar{X}^0 X^- \phi^+ - \bar{X}^0 X^+ \phi^-) + igM s_w (\bar{X}^0 X^- \phi^+ - \bar{X}^0 X^+ \phi^-) + \frac{1}{2}igM (\bar{X}^+ X^+ \phi^0 - \bar{X}^- X^- \phi^0).$$

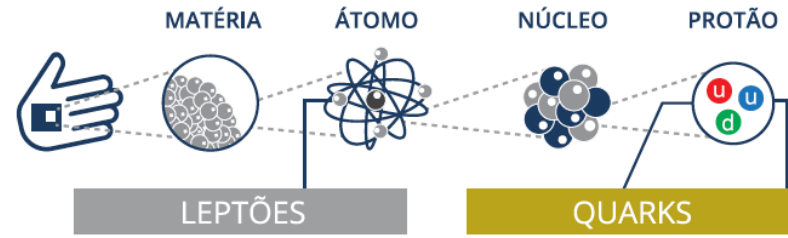

	LEPTÕES		QUARKS		
1ª	ν_e NEUTRINO DO ELETRÃO 0 1/2	e ELETRÃO -1 1/2	u UP 2/3 1/2	d DOWN -1/3 1/2	
2ª	ν_μ NEUTRINO DO MÚÃO 0 1/2	μ MÚÃO -1 1/2	c CHARM 2/3 1/2	s STRANGE -1/3 1/2	
3ª	ν_τ NEUTRINO DO TAU 0 1/2	τ TAU -1 1/2	t TOP 2/3 1/2	b BOTTOM -1/3 1/2	
			g GLUÃO 0 1		FORÇA FORTE
	Z BOSÃO Z 0 1	γ FOTÃO 0 1			FORÇA ELETROMAGNÉTICA
	W [±] BOSÃO W 1 1				FORÇA FRACA
	PARTÍCULAS DAS FORÇAS				
				H HIGGS 0 0	

PARTÍCULAS DE MATÉRIA

Para cada uma destas partículas, existe uma antipartícula de carga oposta (antimatéria)



Legenda

símbolo

NOME

Carga Spin

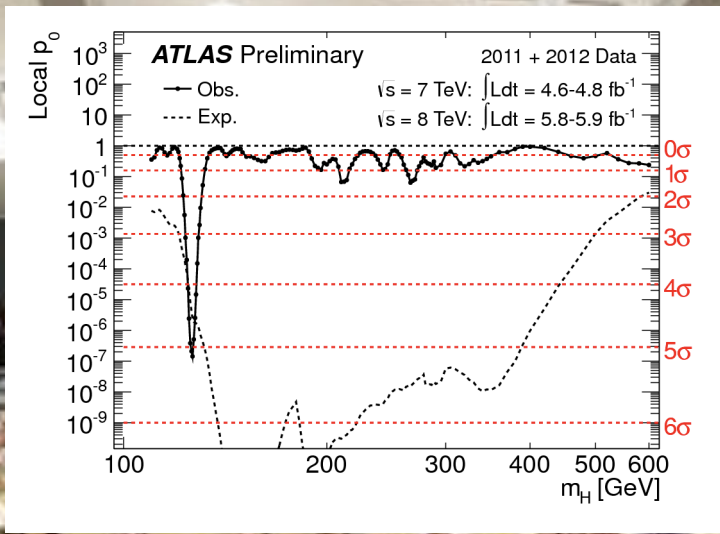

The Long Way to Discovery

A PHENOMENOLOGICAL PROFILE OF THE HIGGS BOSON

John ELLIS, Mary K. GAILLARD * and D.V. NANOPOULOS **
CERN, Geneva

Received 7 November 1975



We should perhaps finish with an apology and a caution. We apologize to experimentalists for having no idea what is the mass of the Higgs boson, unlike the case with charm ^{3),4)} and for not being sure of its couplings to other particles, except that they are probably all very small. For these reasons we do not want to encourage big experimental searches for the Higgs boson, but we do feel that people performing experiments vulnerable to the Higgs boson should know how it may turn up.

Electron-positron collider up to $s^{1/2} = 209$ GeV
Integrated luminosity: ~ 700 pb $^{-1}$

Shutdown: September 2000

Searches at LEP

OPAL

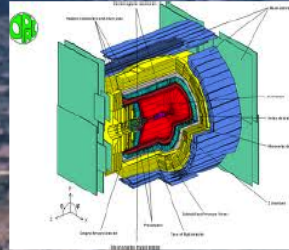

DELPHI

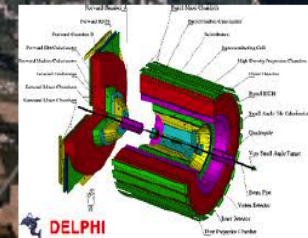

ALEPH

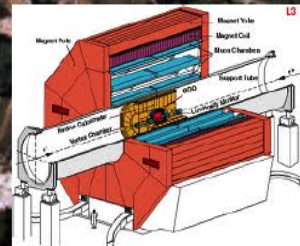
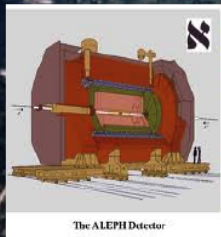

L3

Low-mass searches at LEP

The decay branching ratios depend only on m_H :

□ $m_H < 2m_e$: $H \rightarrow \gamma\gamma$ + large lifetime;

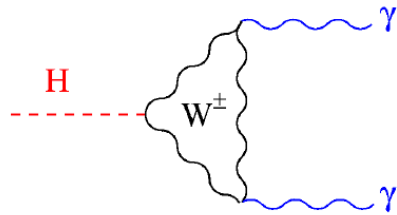

□ $m_H < 2m_\mu$: $H \rightarrow e^+e^-$ dominates;

□ $m_H < 2m_\pi$: $H \rightarrow \mu^+\mu^-$ dominates;

□ $m_H < 3 - 4 \text{ GeV}$: $H \rightarrow gg$ dominates;

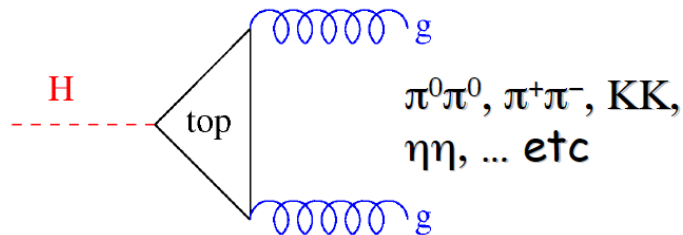

□ $m_H < 2m_b$: $H \rightarrow \tau^+\tau^-$ and $c\bar{c}$ dominate;

□ $m_H > 2m_b$ up to $1000 \text{ GeV}/c^2$:

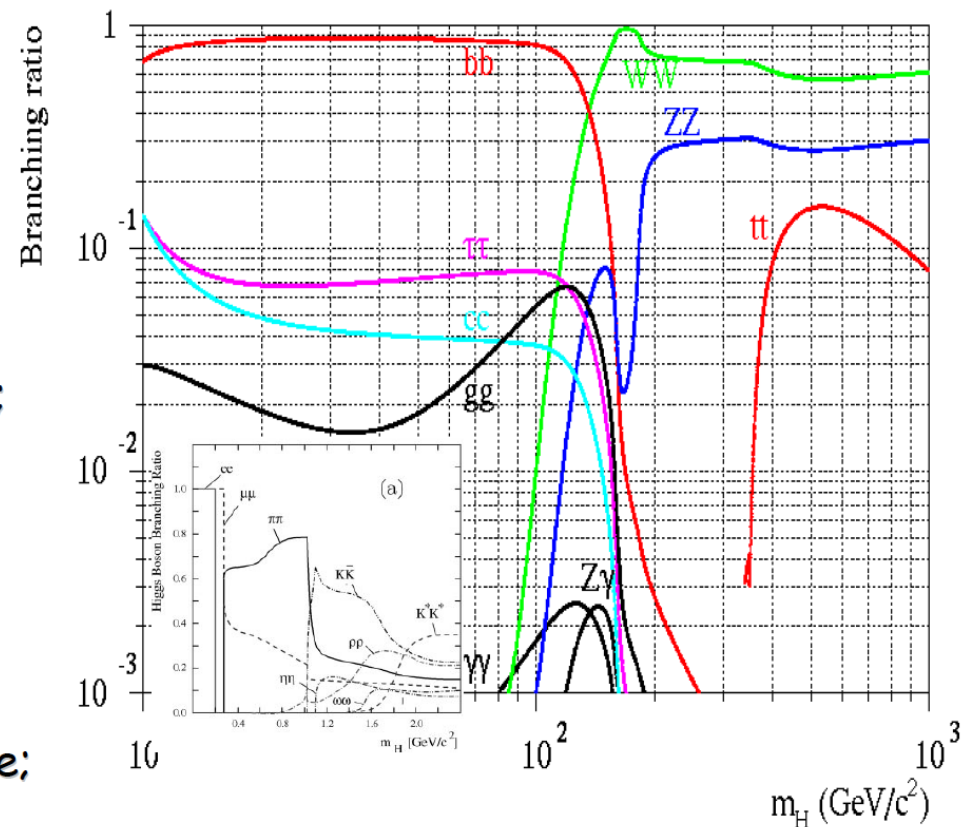

Higher-mass Higgs production at LEP

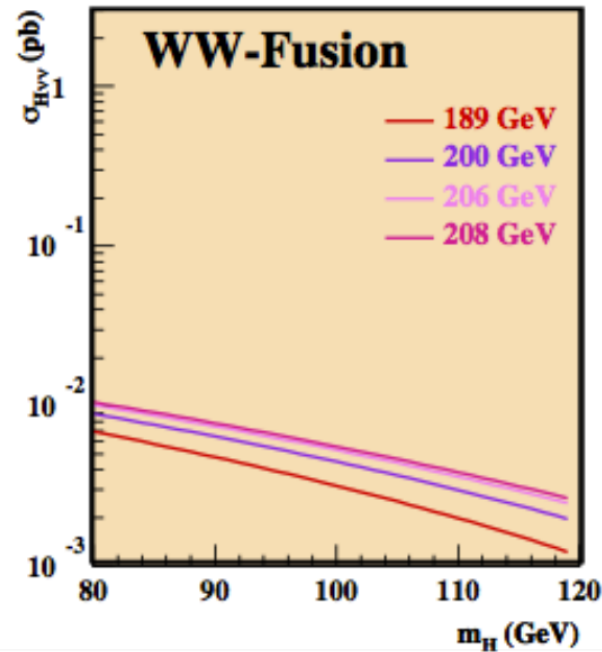
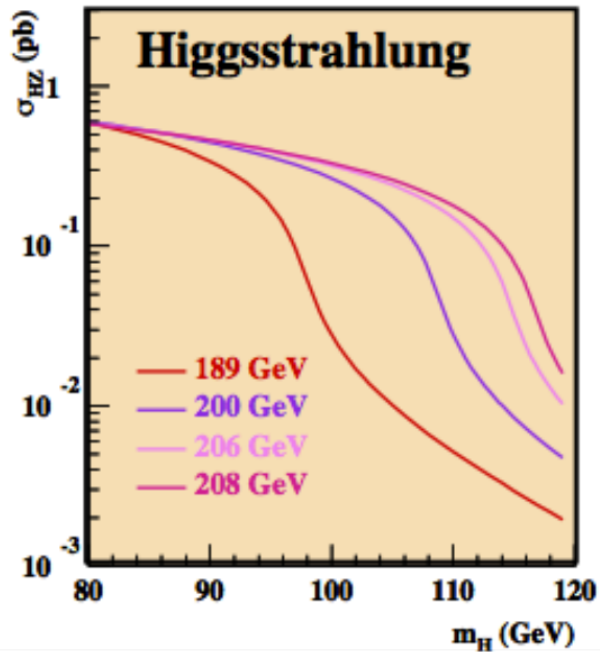
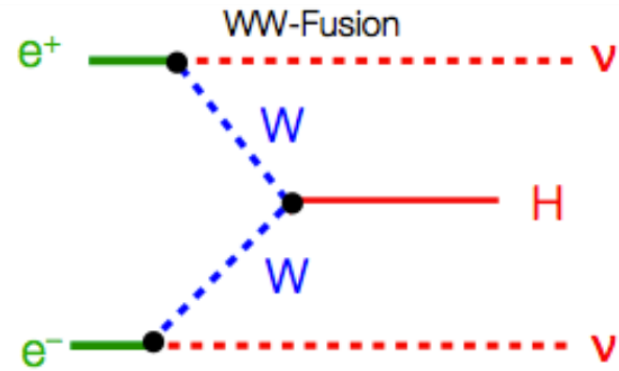
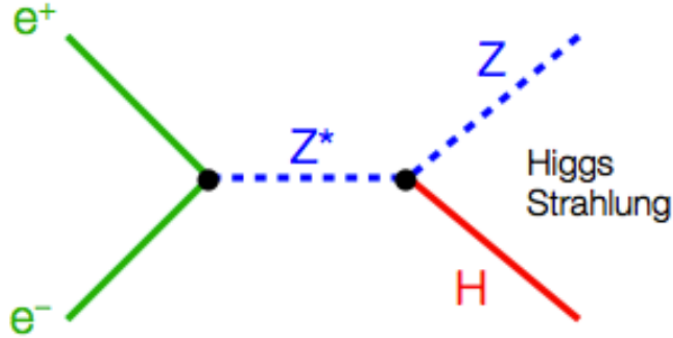

Higgs decays: focus on 3rd generation

<p>$H \rightarrow b\bar{b}$ $Z \rightarrow q\bar{q}$</p>	4-jets	51%	<p>$WW \rightarrow qq\bar{q}\bar{q}$ $ZZ \rightarrow qq\bar{q}\bar{q}$ QCD 4-jets</p>
<p>$H \rightarrow b\bar{b}$ $Z \rightarrow \nu\bar{\nu}$</p>	missing energy	15%	<p>$WW \rightarrow qq\nu\bar{\nu}$ $ZZ \rightarrow bb\nu\bar{\nu}$</p>
<p>$H \rightarrow b\bar{b}$ $Z \rightarrow \tau^+\tau^-$</p>	τ -channel	2.4%	<p>$WW \rightarrow qq\tau\nu$ $ZZ \rightarrow bb\tau\tau$ $ZZ \rightarrow qq\tau\tau$ QCD low mult. jets</p>
<p>$H \rightarrow \tau^+\tau^-$ $Z \rightarrow q\bar{q}$</p>	τ -channel	5.1%	
<p>$H \rightarrow b\bar{b}$ $Z \rightarrow e^+e^-$ $\mu^+\mu^-$</p>	lepton channel	4.9%	<p>$ZZ \rightarrow bbee$ $ZZ \rightarrow bb\mu\mu$</p>

Summary of all Higgs candidates found at LEP

Invariant mass of all candidates

In total 17 candidates selected

- 15.8 background events expected

Expectation for $m_H = 115$ GeV

- 8.4 events

Corresponding excess was not observed

Final verdict from LEP

$m_H > 114.4$ GeV @ 95% CL

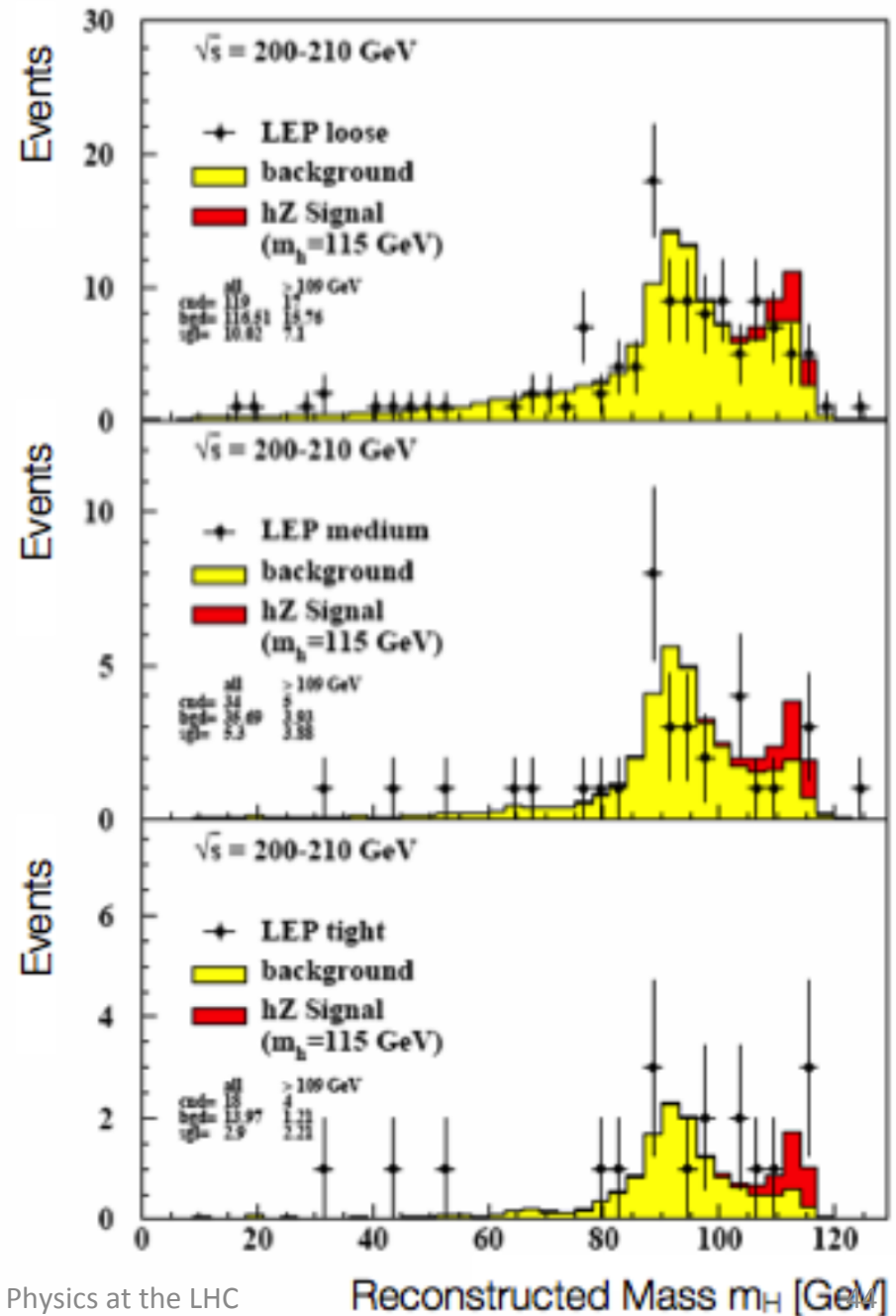

LEP's Final Legacy: the Blue Band Plot

- Decades of searches in many experiments...
- By July 2010:
 - LEP+Tevatron+SLD limits
 - Higgs excluded $m_h < 114.4$ GeV at 95% CL
 - Plus between 158 and 175 GeV

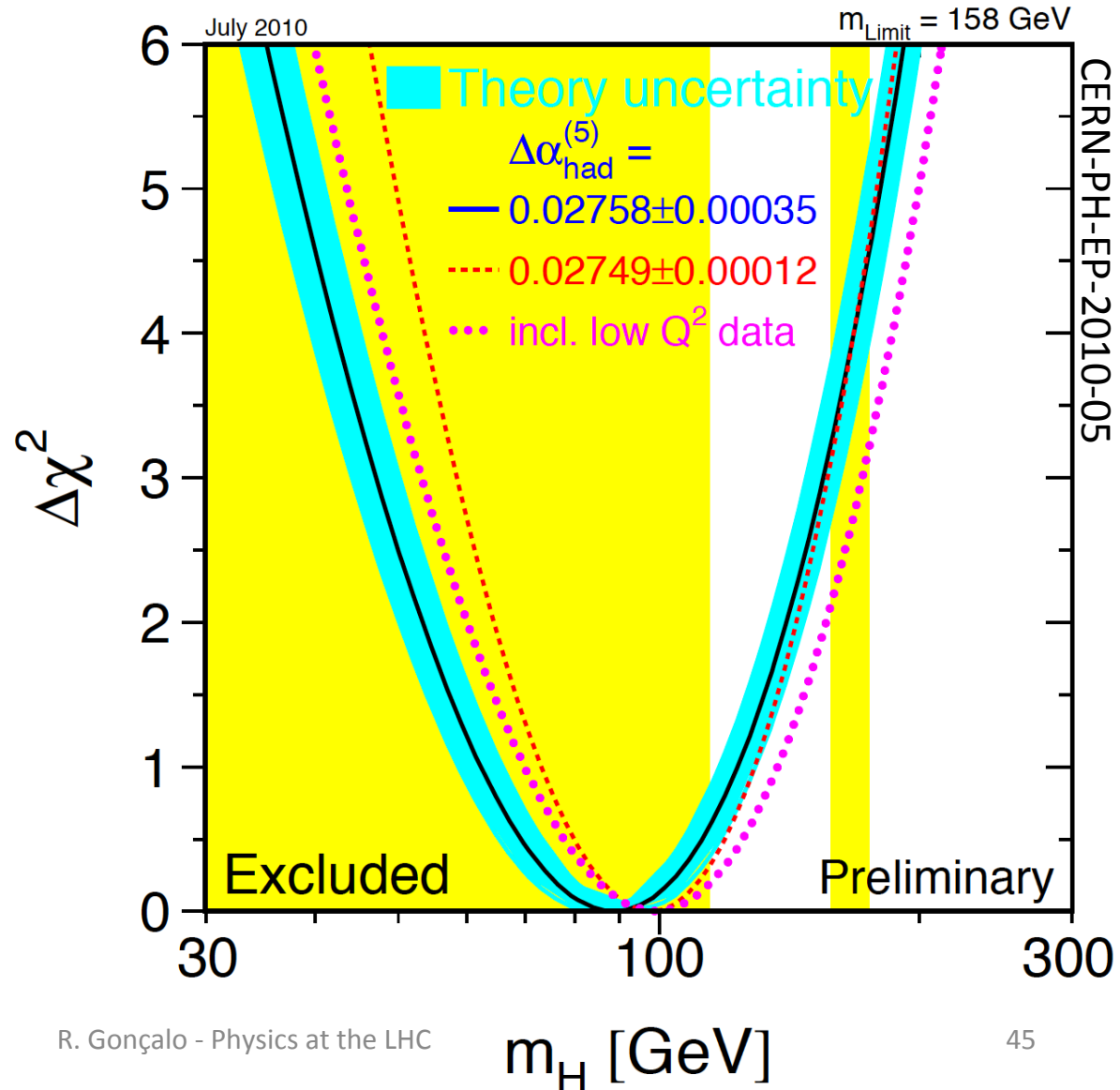

Searches at the Tevatron



Proton-anti-proton collider at $s^{1/2}=1.96$ TeV
First superconducting accelerator
Shutdown: 30 September 2011
Almost 10 fb^{-1} of data for analysis

Higgs production at the Tevatron

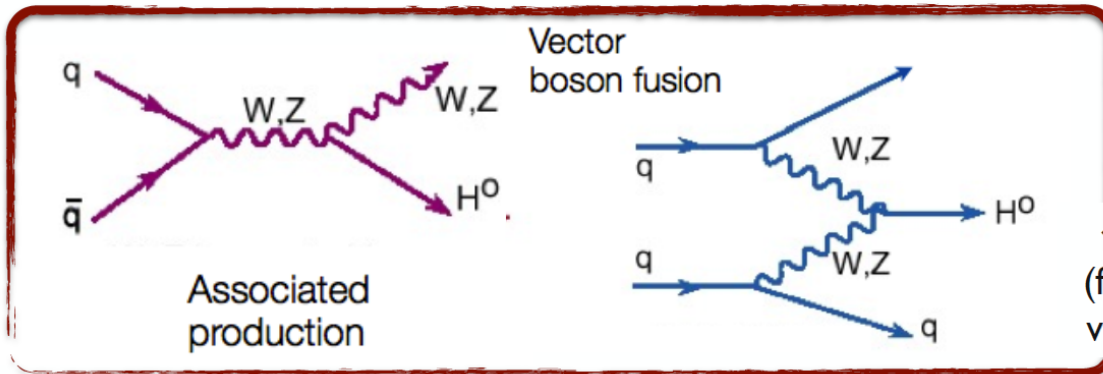

(fermion annihilation and vector boson scattering)

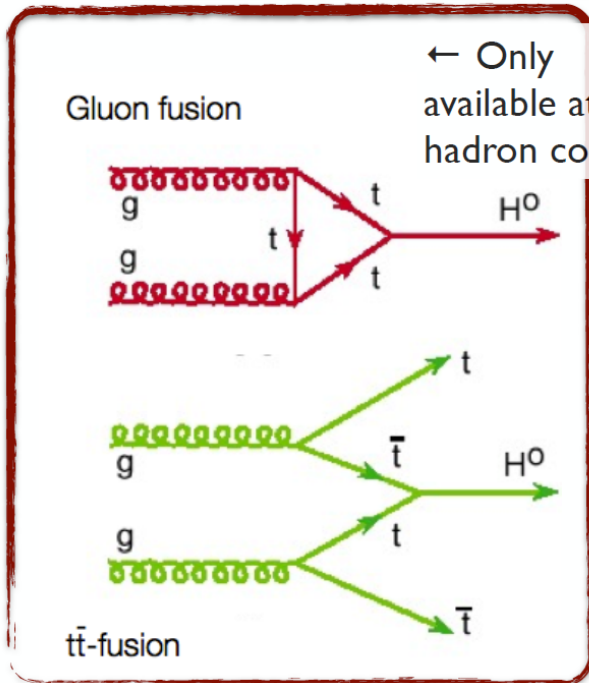

← Only available at hadron colliders

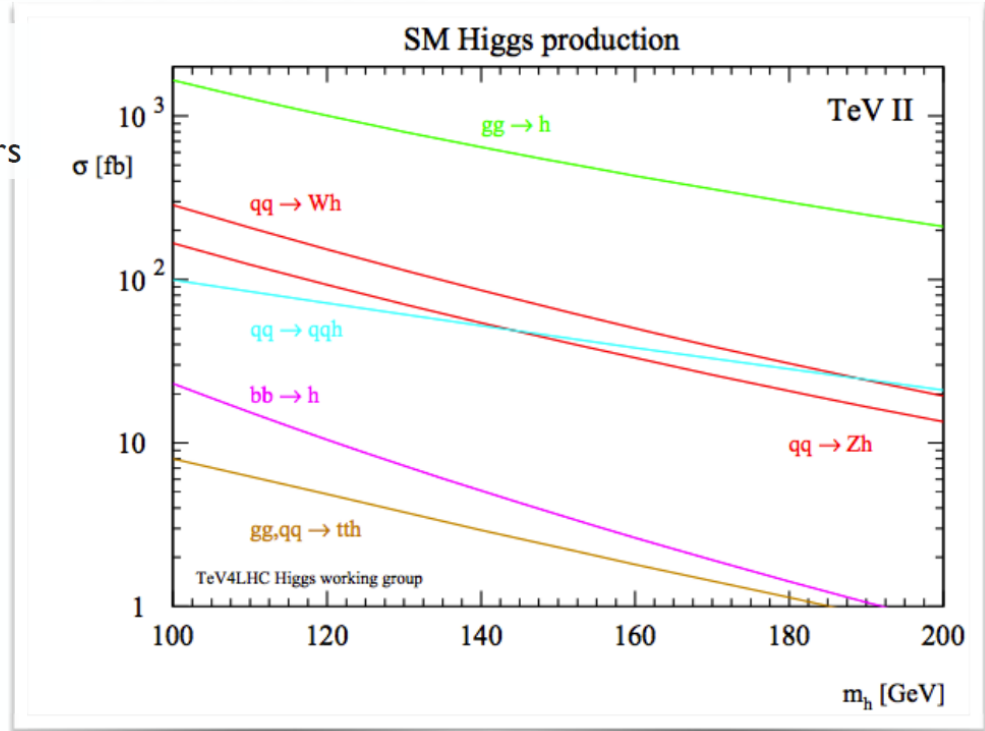

Most sensitive searches

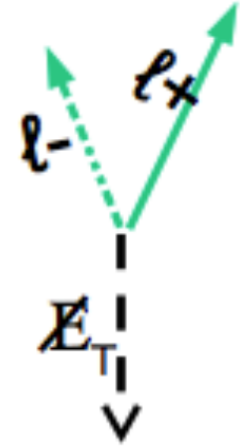
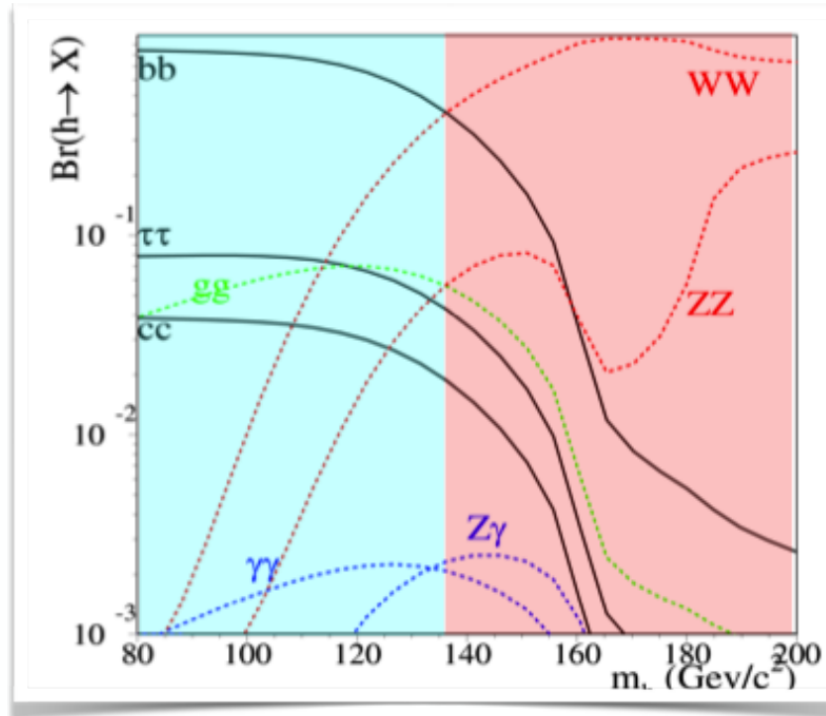
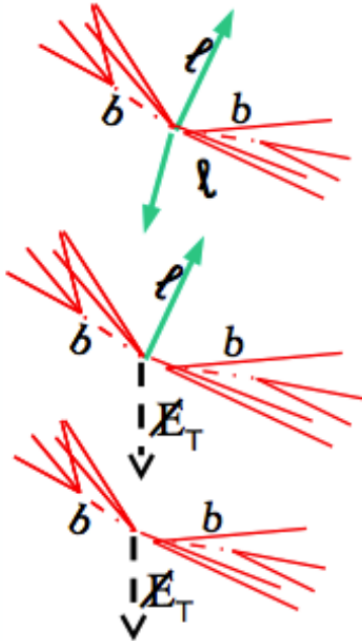

At low mass use $h \rightarrow bb$ final states

- associated production with W or Z
- challenging: b-tagging, jet resolution
- backgrounds: top, W/Z+heavy flavour di-bosons

At high mass use $H \rightarrow WW$ final states

- benefit from high gluon-gluon cross section
- challenging: lepton acceptance, missing energy
- backgrounds: top, di-bosons

The final stand of the Tevatron

- By the end of its lifetime, the Tevatron had very sophisticated analyses of a huge number of channels
- By that time the LHC was collecting data and analysing it very fast
- The CDF and D0 experiments obtained a significant excess of around 3 standard deviations in the mass range $115 < M_H < 140$ GeV
- Not enough to claim discovery, but consistent with the LHC results

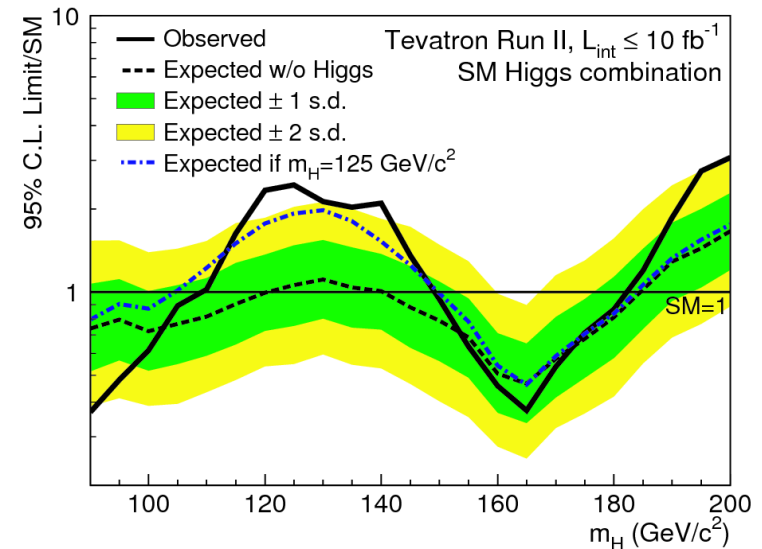
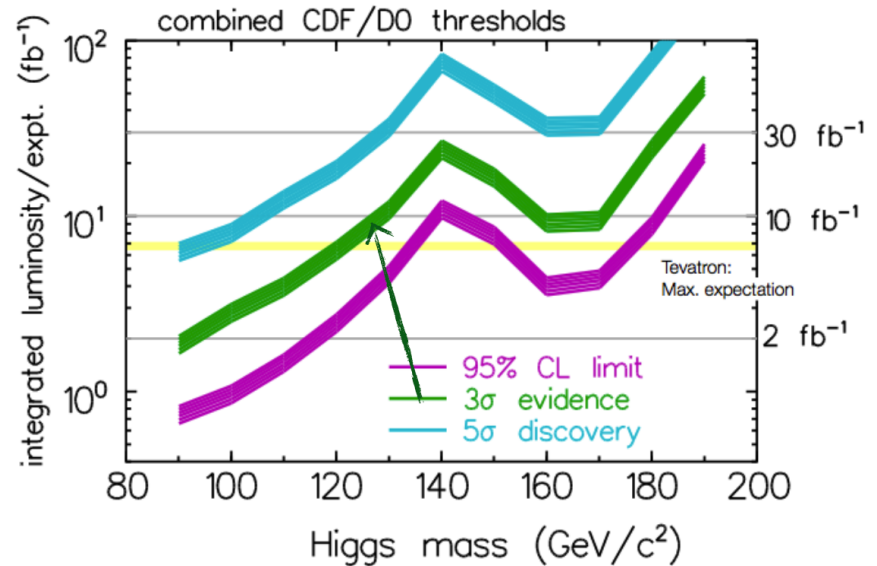

Discovery at the LHC

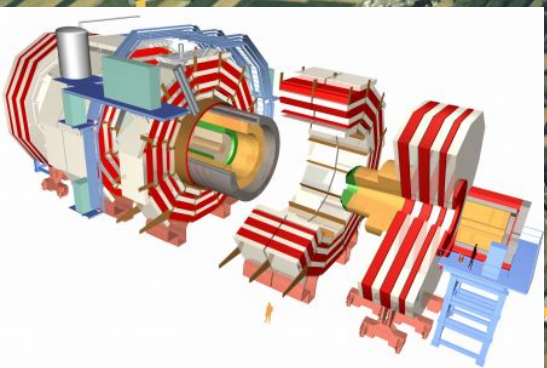
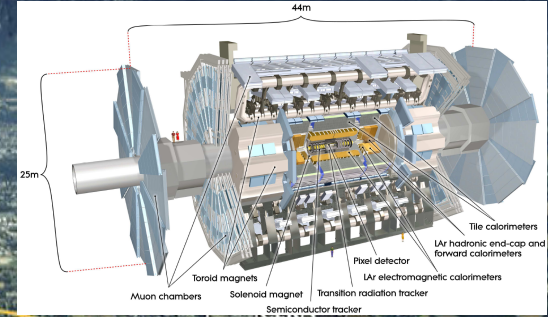
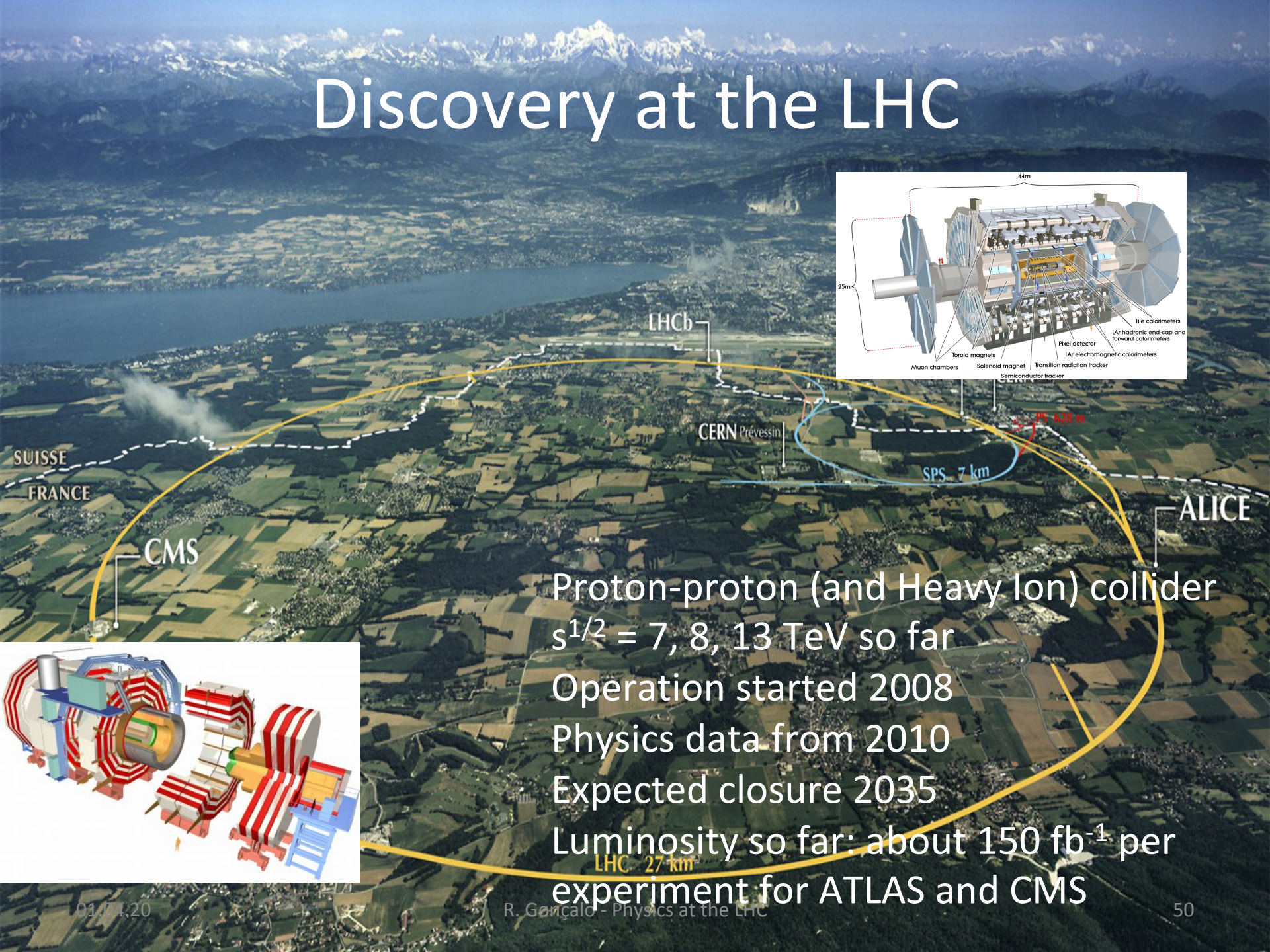

Proton-proton (and Heavy Ion) collider
 $s^{1/2} = 7, 8, 13$ TeV so far
Operation started 2008
Physics data from 2010
Expected closure 2035
Luminosity so far: about 150 fb^{-1} per experiment for ATLAS and CMS

At the LHC

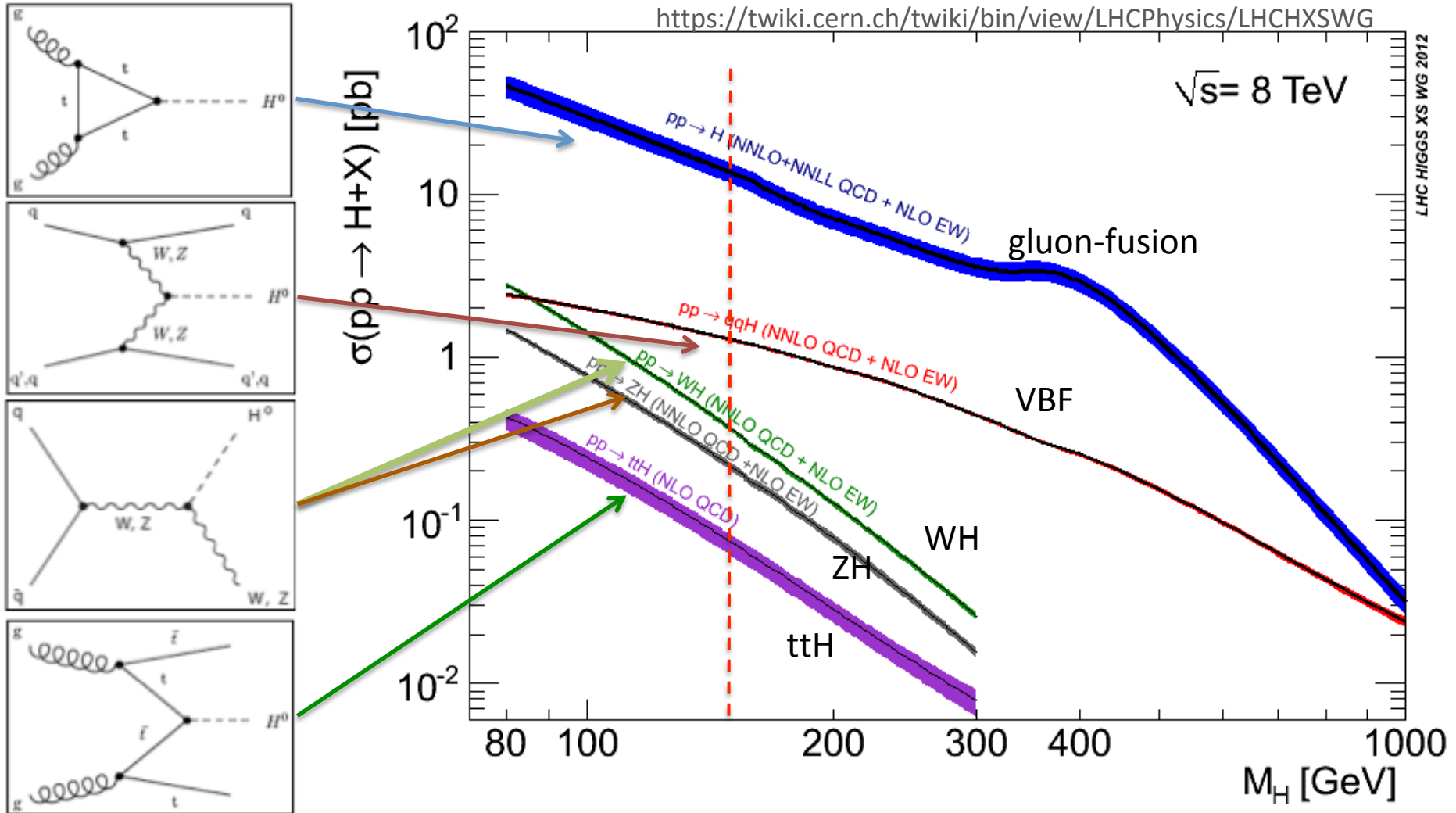

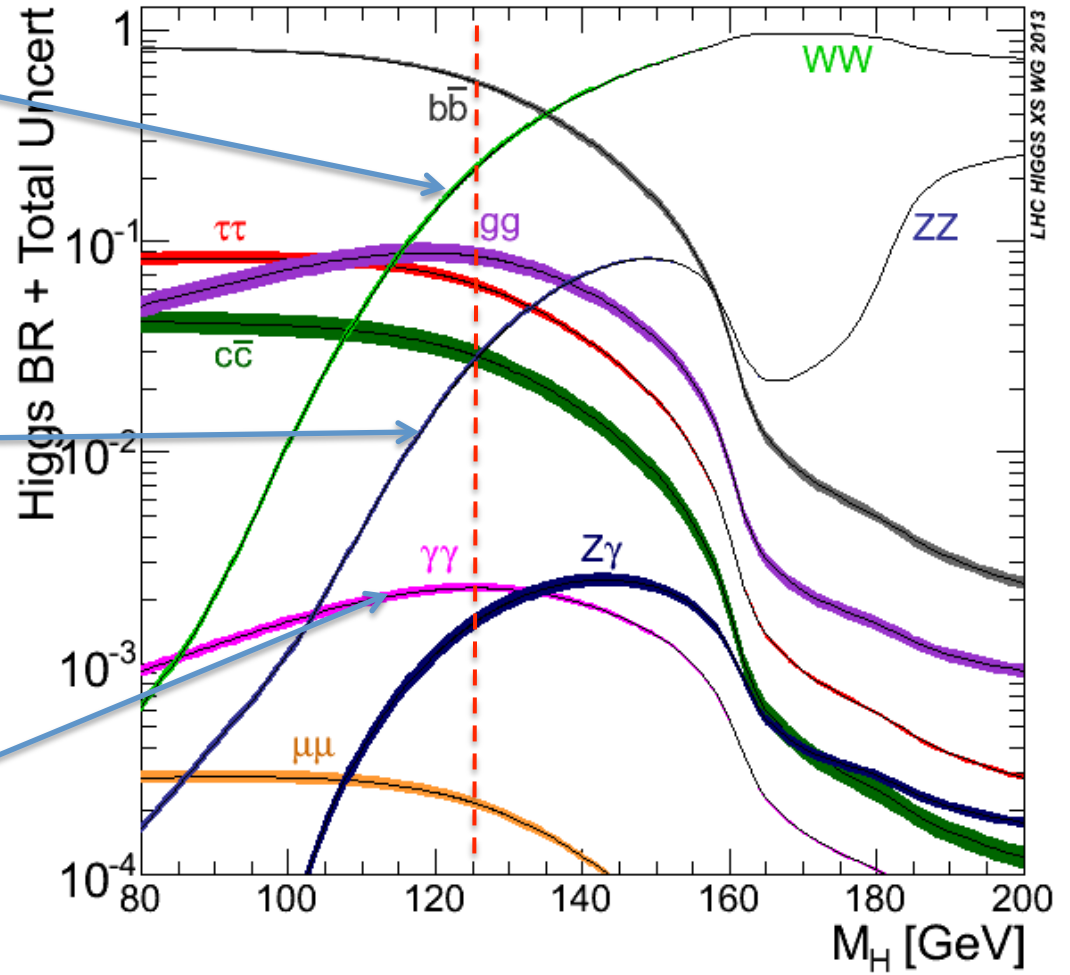
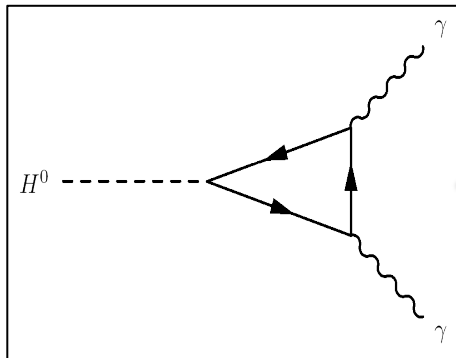
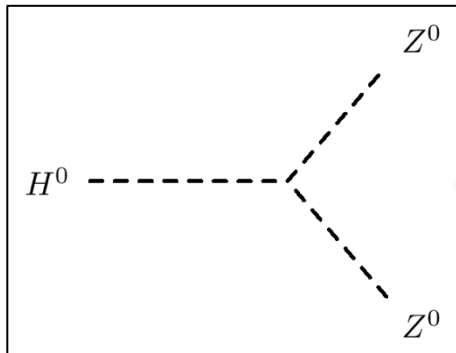
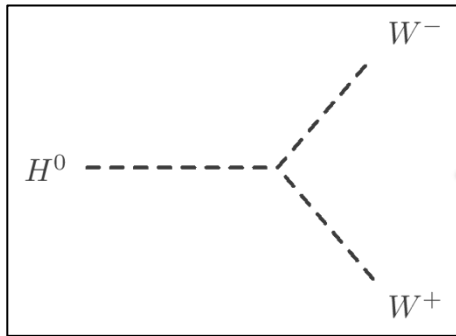

2012: Descoberta do bóson de Higgs: $H \rightarrow \gamma\gamma$

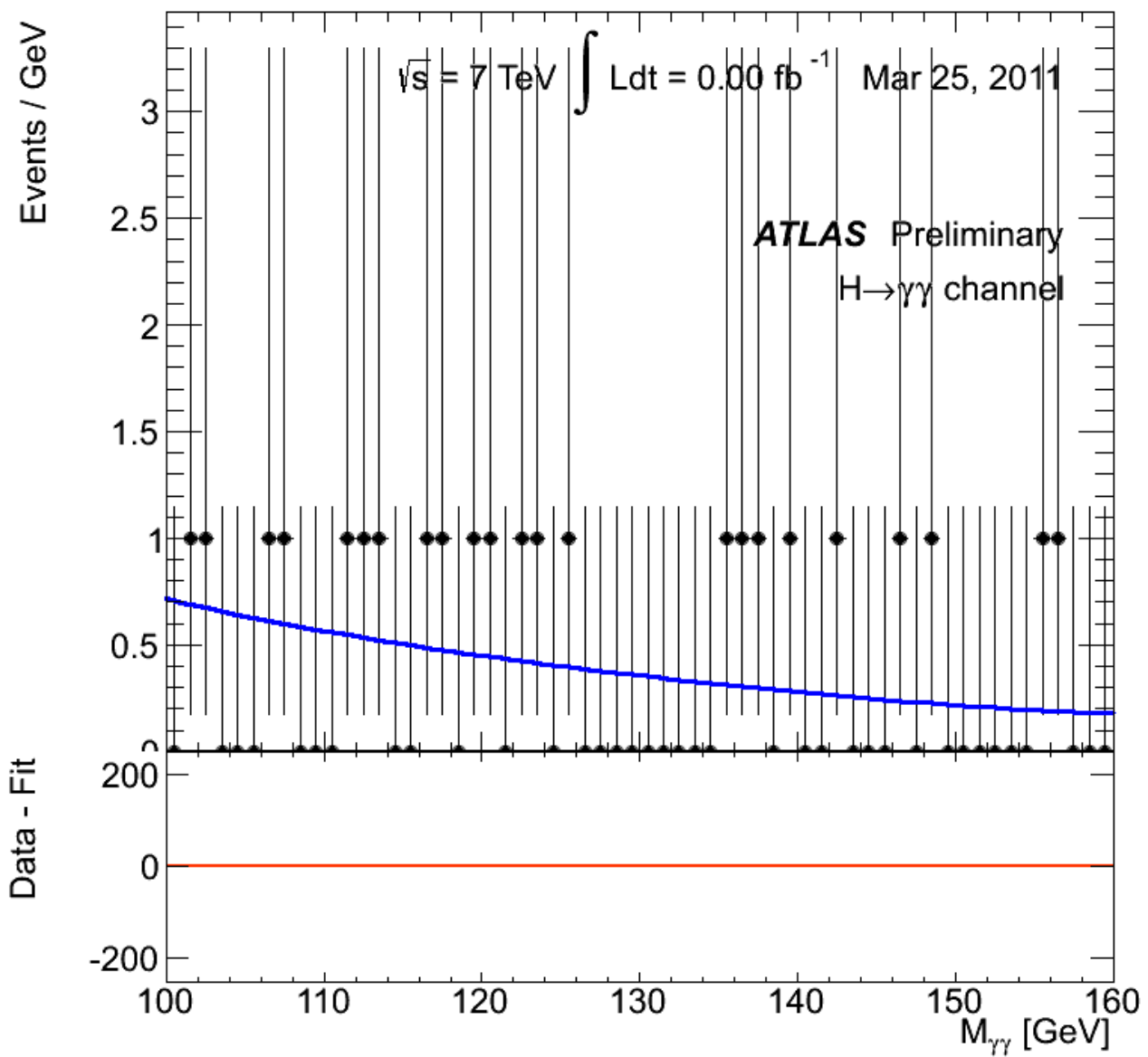

Discovery channels

- Discovery was made in ATLAS and CMS with about 5 fb^{-1} of 7 TeV data and 20 fb^{-1} of 8 TeV data per experiment; several channels combined

$$h \rightarrow \gamma\gamma; h \rightarrow ZZ^* \rightarrow 4\ell; h \rightarrow WW^*; h \rightarrow \tau^+\tau^-; h \rightarrow b\bar{b}$$

- This means about 400 000 Higgs bosons produced in about 8 000 000 000 000 000 (8×10^{15}) proton collisions
 - Only about 4000 events with Higgs bosons contributed to the discovery

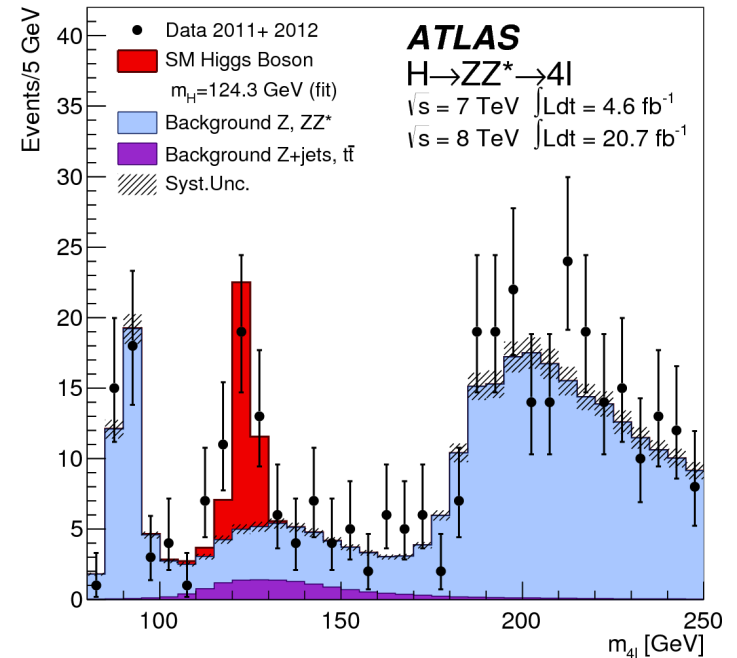
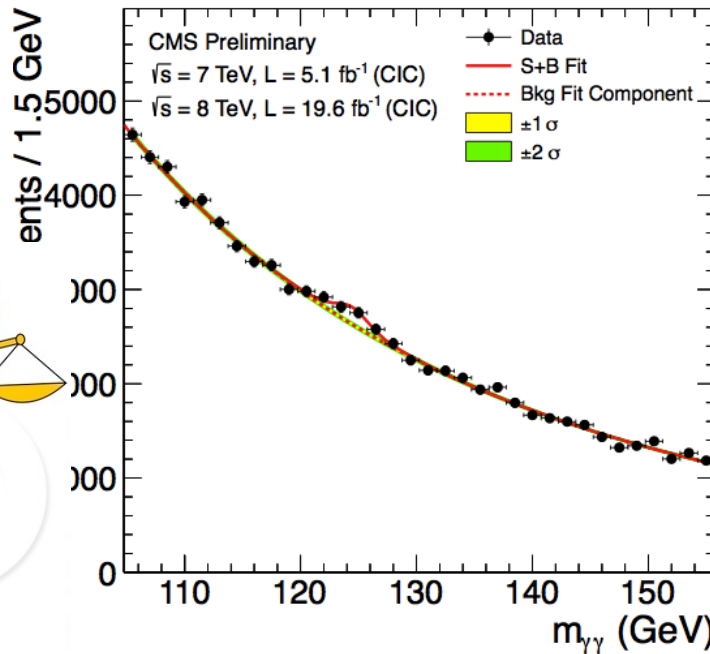

Combining Higgs Channels

Production

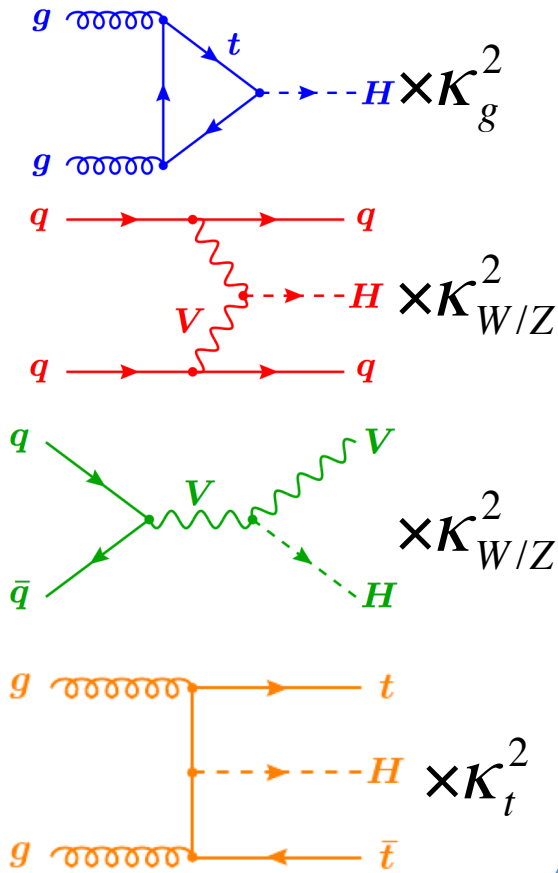

Decay

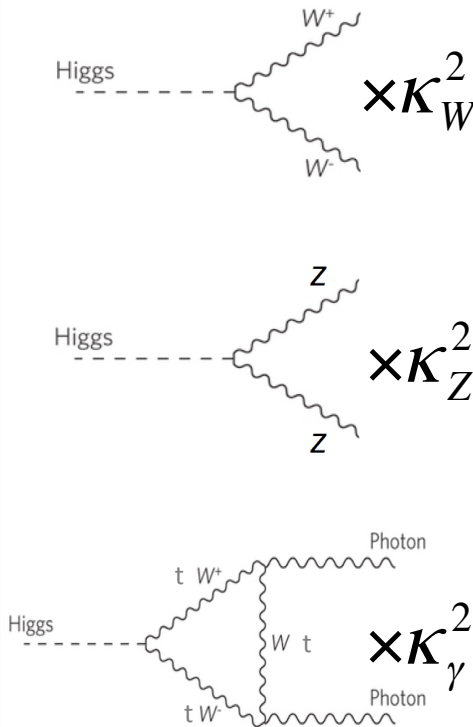

X

FIT

Backgrounds +

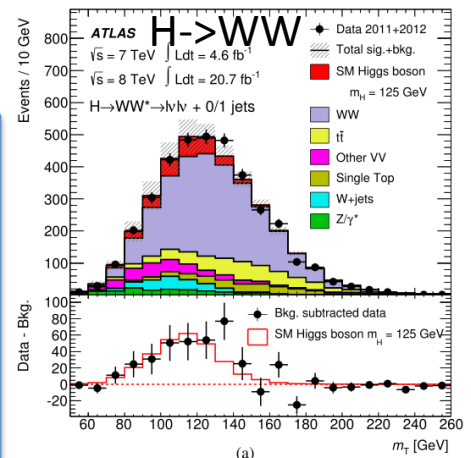
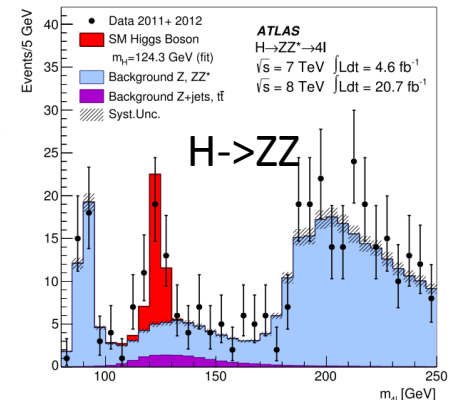
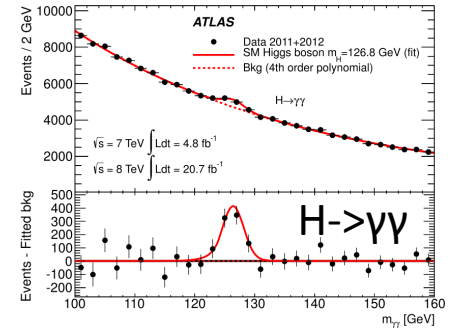

The p_0 Discovery Plot

- p_0 is the combined probability that the background fluctuates to look like signal
- Translated into the one-sided Gaussian probability

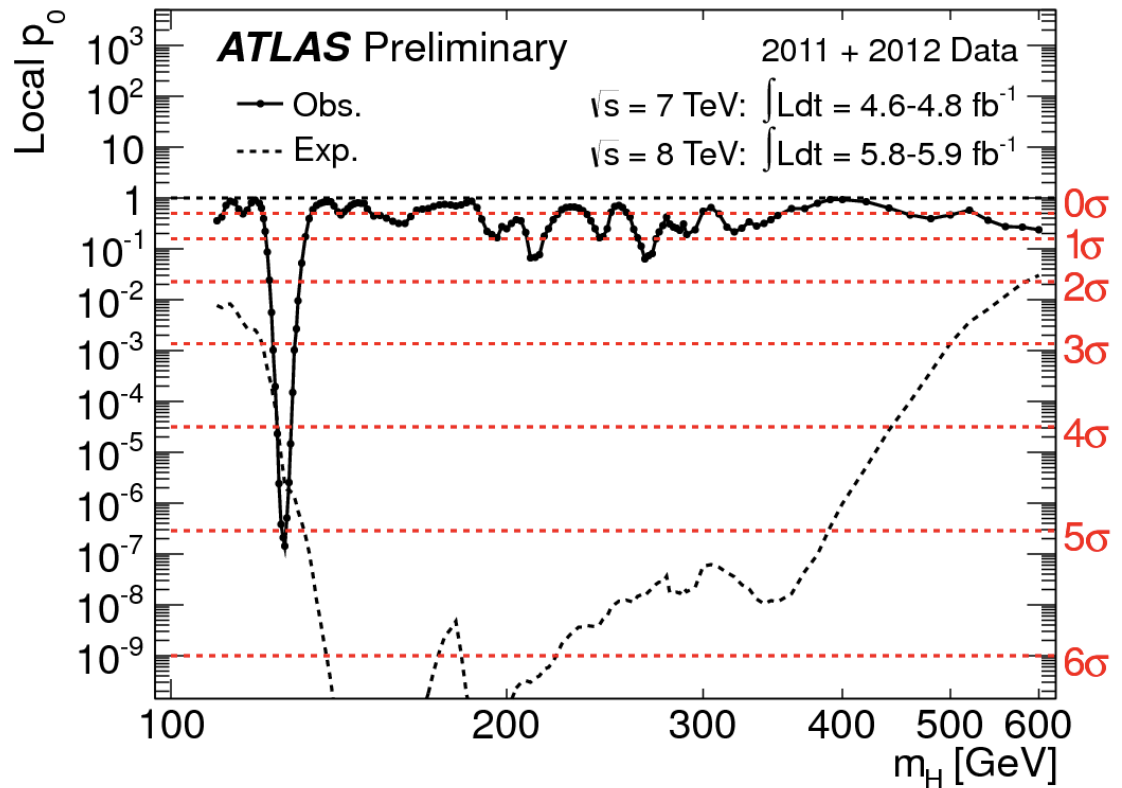

- This corresponds to a probability of **1 in 3.5 million** that this was a false positive from fluctuating backgrounds

2013 Physics Nobel Prize Higgs for the Higgs Boson Discovery

François Englert, Belga, born 1932, U. Libre de Bruxelles



Peter Higgs, English, born 1929, Univ. of Edinburgh

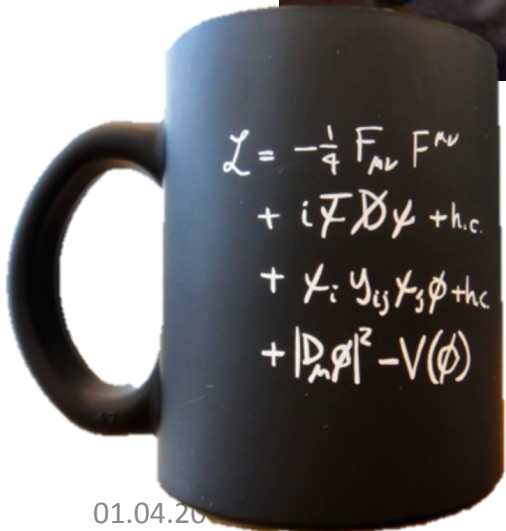

*"for the **theoretical discovery** of a mechanism that contributes to our understanding of the origin of mass of subatomic particles, and which recently was confirmed through the **discovery of the predicted fundamental particle, by the ATLAS and CMS experiments at CERN's Large Hadron Collider**"*



First observations of a new particle in the search for the Standard Model Higgs boson at the LHC

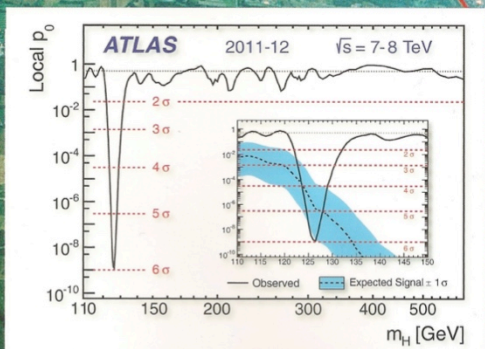
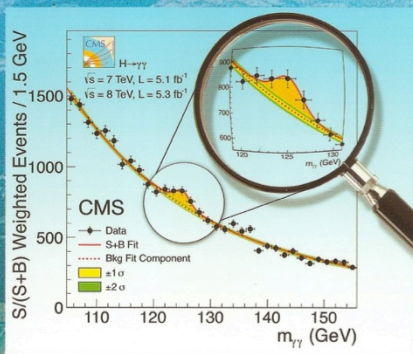

www.elsevier.com/locate/physletb

Two quotations from the experimental papers presented in this publication:

"... The search for the Higgs boson, the only elementary particle in the Standard Model that has not yet been observed, is one of the highlights of the Large Hadron Collider physics program."

- ATLAS Collaboration

"... The decay to two photons indicates that the new particle is a boson with spin different from one. The results presented here are consistent, ... with expectations for a standard model Higgs boson."

- CMS Collaboration

Best wishes!
Peter Higgs

It takes time to get it right

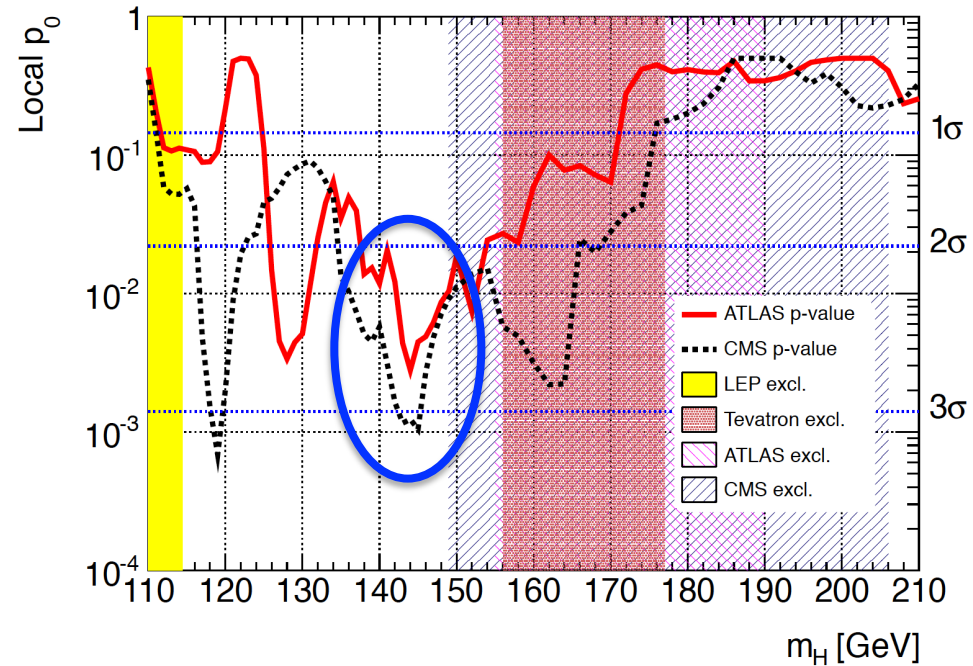

EPS-HEP 2011 conference [6]

Probing the 125 GeV Higgs



Spin and Parity

- First concern after observation!
- Some observable quantities sensitive to J^P : for example angle between leptons from W decay in $H \rightarrow WW$
- Pure $J^P = 0^-, 1^+, 1^-, \text{ and } 2^+$ excluded with 97.8, 99.97, 99.7, and 99.9% Confidence Level (ATLAS arXiv 1307.1432; CMS Phys. Rev. D 92, 012004)

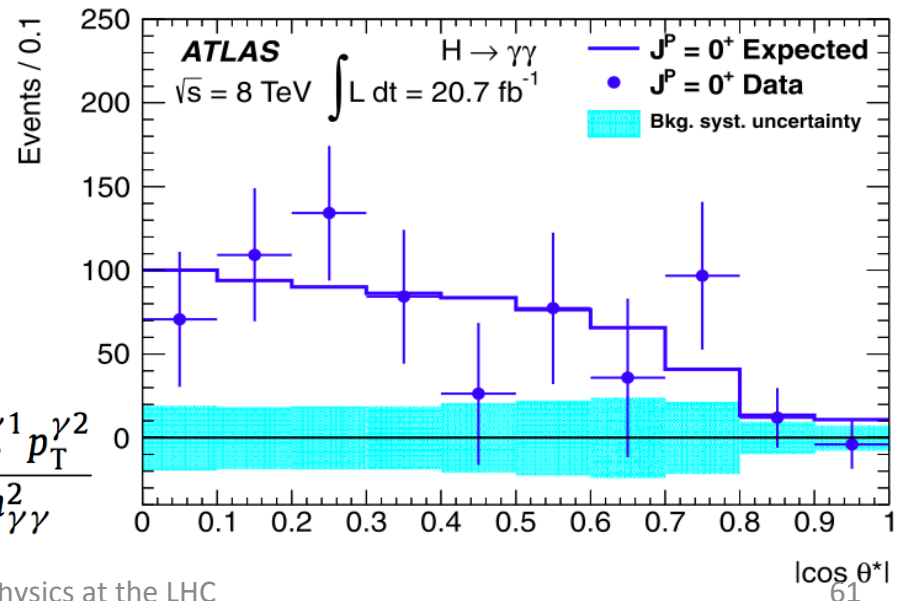
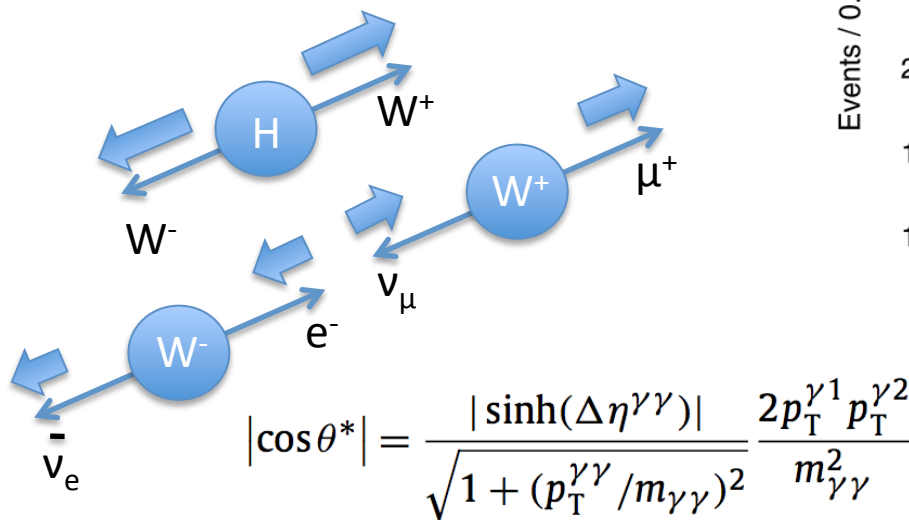

Higgs boson mass

- **Mass:** around 125GeV
Was the only unknown SM parameter 😊
- For a while, different mass values were being measured in ATLAS and CMS, and in different channels
- Numbers evolved with accumulated statistics
- Current most precise value from ATLAS+CMS has 0.2% precision!

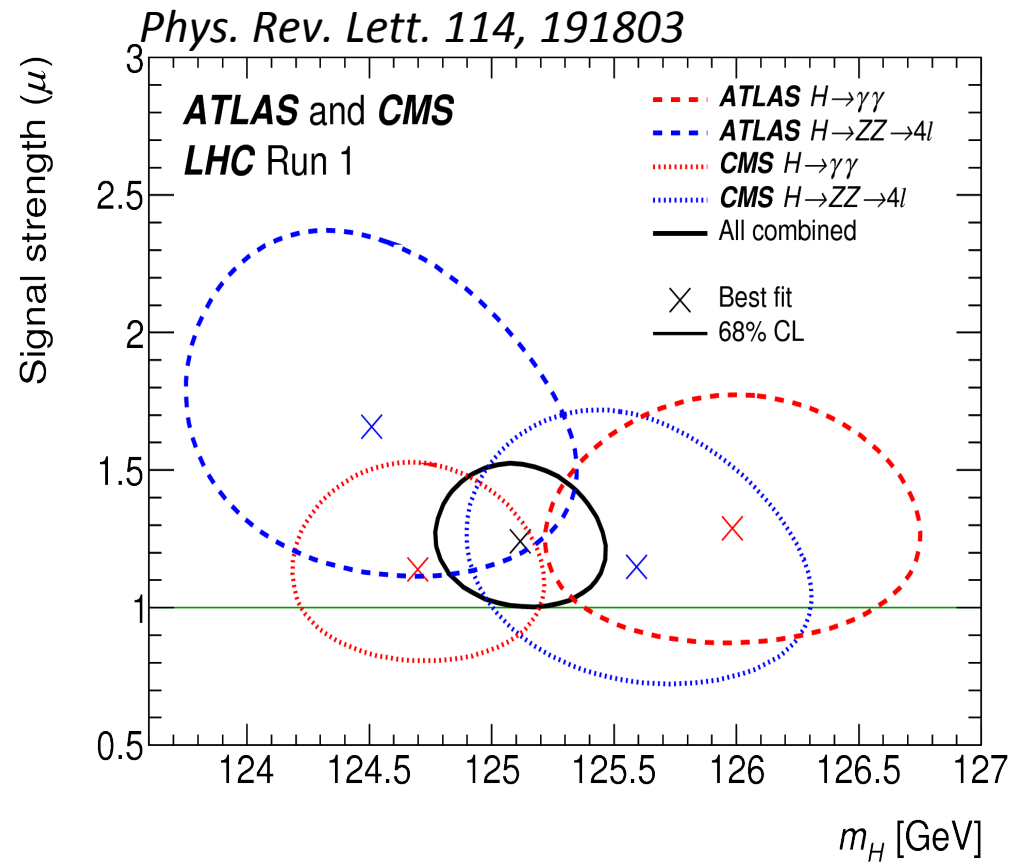

$$m_H = 125.09 \pm 0.21 \text{ (stat)} \pm 0.11 \text{ (syst)} \text{ GeV}$$

Cross section compared to SM expectation

$$\frac{\sigma_{meas} \cdot BR}{\sigma_{SM} \cdot BR}$$

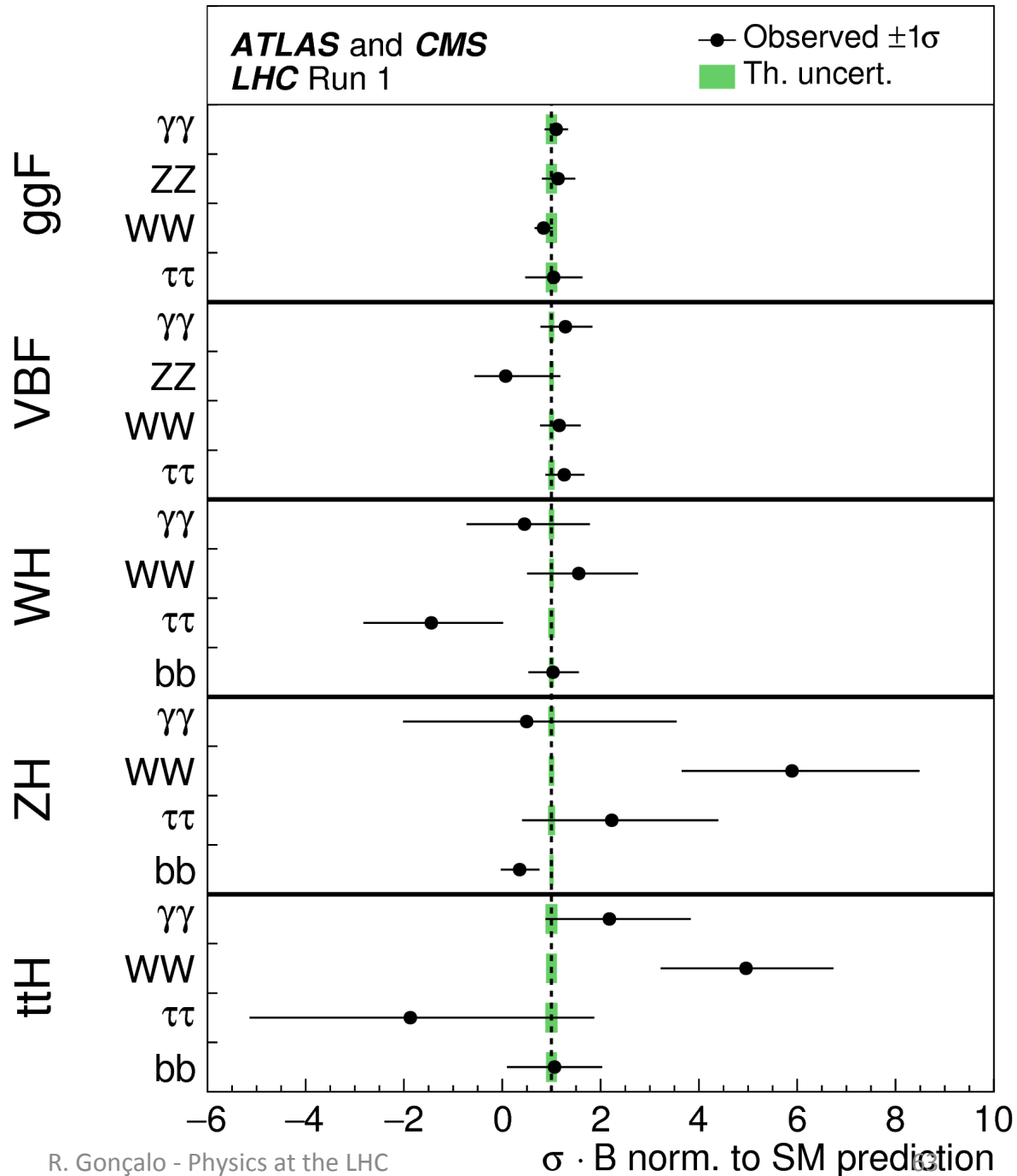

Exploring the electroweak scale

- Precision measurements of m_W , m_t , m_H are stringent tests of the SM at the EW scale
 - E.g. excluding measured m_H , global EW fit gives $m_H = 90 \pm 21$ GeV (1.7σ tension) driven in part by m_{top}

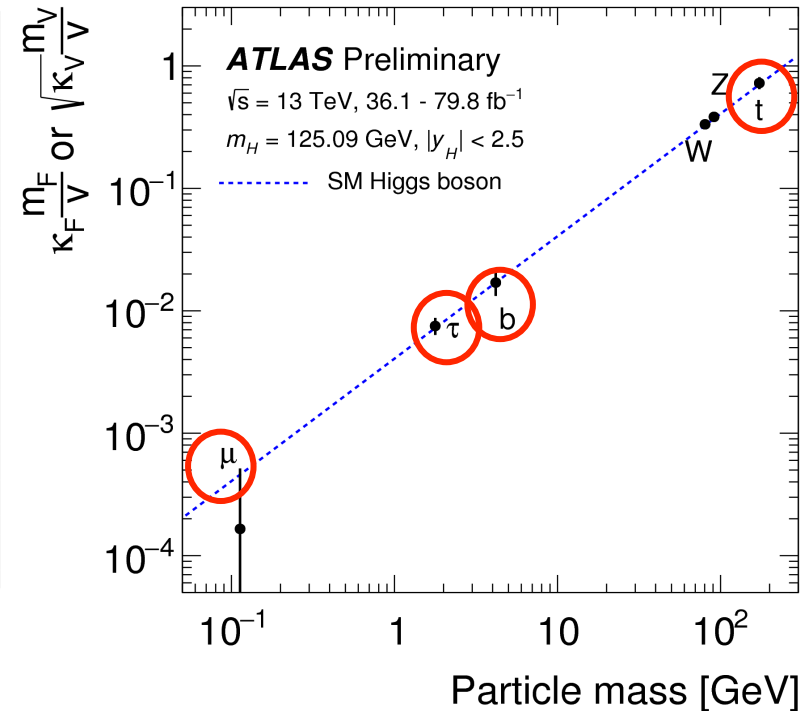
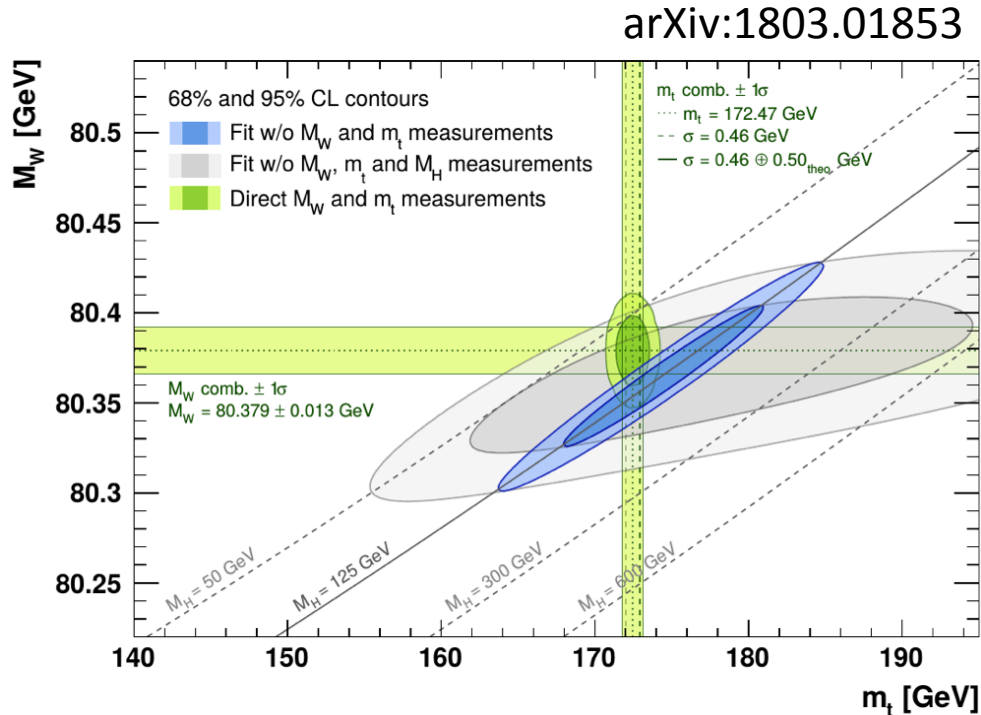

The Run 1 legacy

- Mass – Higgs mass measured with **0.4%** accuracy:
 - $m_H = 125.09 \pm 0.21$ (stat.) ± 0.11 (scale) ± 0.02 (other) ± 0.01 (theory) GeV
- Couplings:
 - ggF with $H \rightarrow ZZ, \gamma\gamma, WW$ **observed** by individual experiments
 - VBF and $H \rightarrow \tau\tau$ observed with $>5\sigma$ significance by ATLAS+CMS combination
 - ttH, VH production and $H \rightarrow bb$ **not observed** during Run1
- Couplings **compatible with SM**:
 - Signal strength: $\mu_{VBF+VH}/\mu_{ggF+ttH} = 1.06^{+0.35}_{-0.27}$
 - Coupling modifiers broadly consistent with SM but still large uncertainty

$$\mu = (\sigma \times BR)_{Obs} / (\sigma \times BR)_{SM}$$

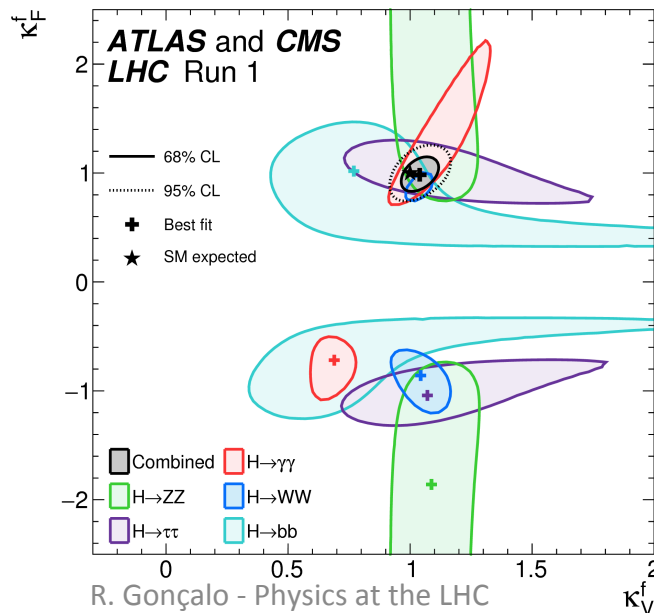
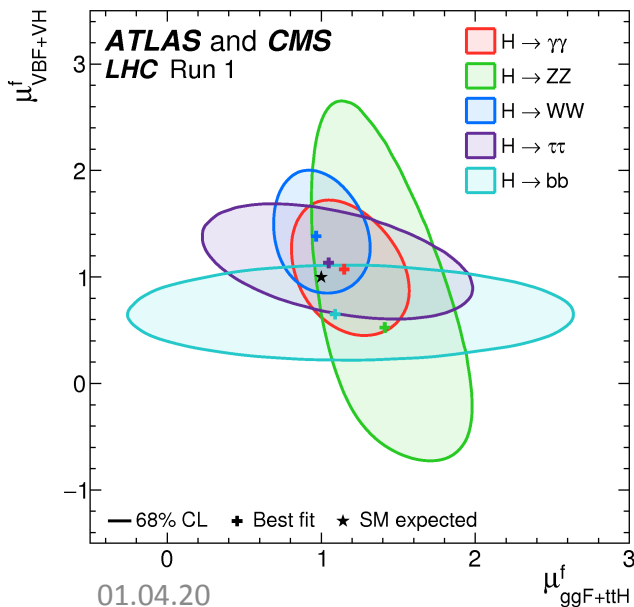

Significance (σ)		
Prod.	Obs.	Expect.
VBF	5.4	4.7
VH	3.5	4.2
ttH	4.4	2.0
Decay	Obs.	Expect.
$H \rightarrow \tau\tau$	5.5	5.0
$H \rightarrow bb$	2.6	3.7

Run 2: Higgs boson mass

- Mass measurement from CMS $H \rightarrow ZZ^* \rightarrow 4l$:
 $m_H^{ZZ^*} = 125.26 \pm 0.20$ (stat) ± 0.08 (syst) GeV
- New Measurements from ATLAS
 $H \rightarrow \gamma\gamma$: $m_H^{\gamma\gamma} = 124.93 \pm 0.40$ GeV
 $H \rightarrow ZZ^* \rightarrow 4l$: $m_H^{ZZ^*} = 124.79 \pm 0.37$ GeV
- Run 1+2 combination from ATLAS:
 $m_H = 124.97 \pm 0.19$ (stat) ± 0.13 (syst.) GeV

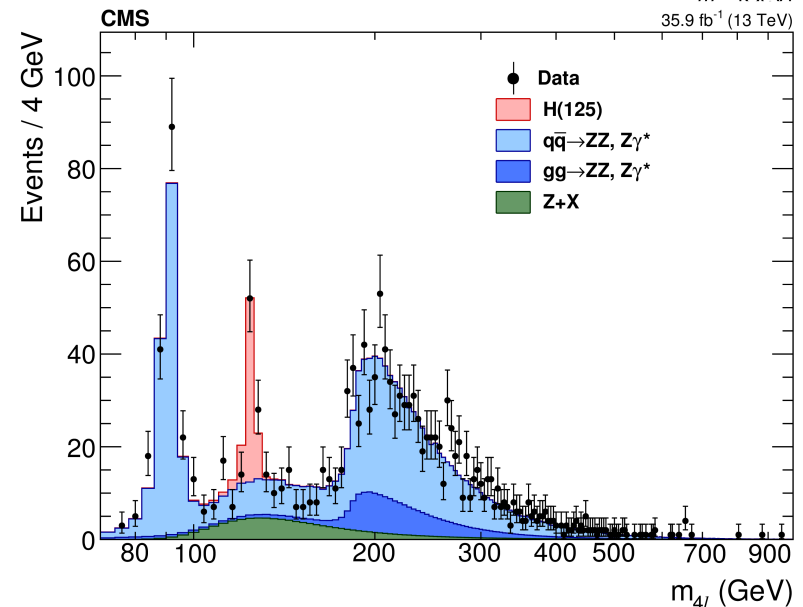
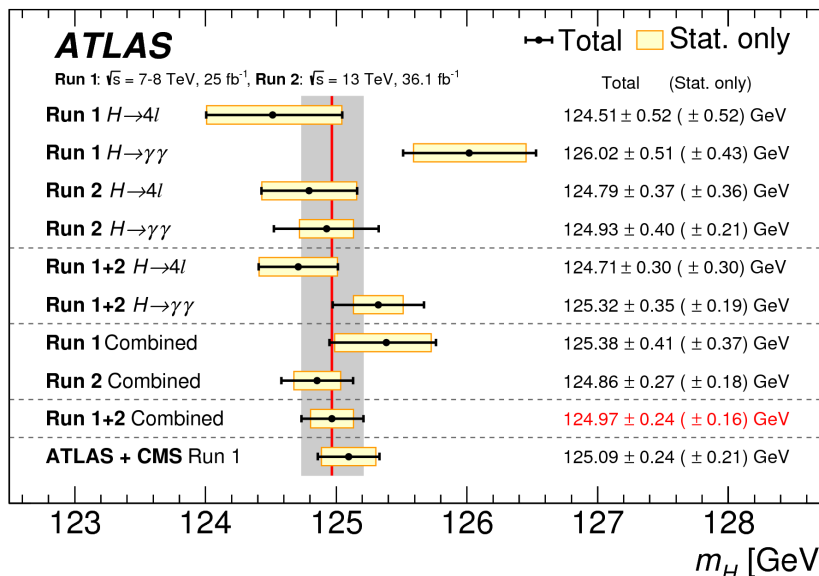
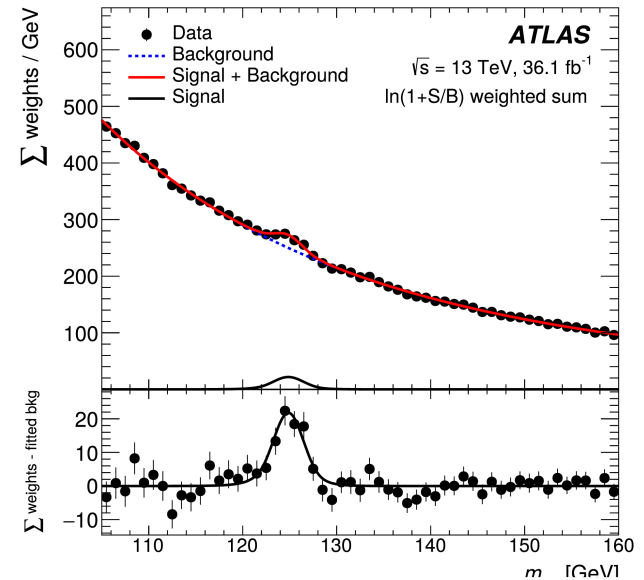

Differential Higgs boson cross sections

- Reached a new phase in the exploration of the Higgs sector!
- Differential cross sections:
 - Higgs p_T sensitive to new physics in gluon-fusion loop
 - Number of jets sensitive to modeling of radiation and different production modes

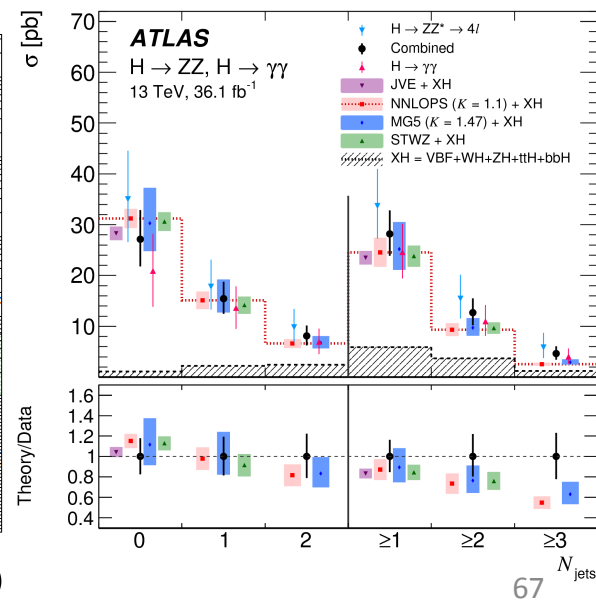
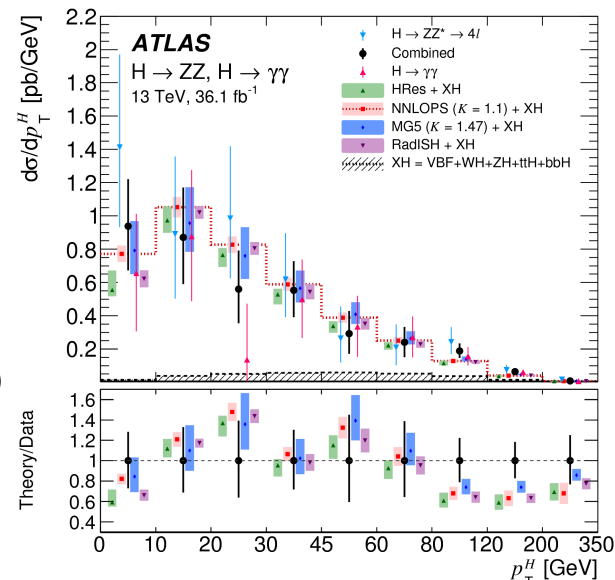
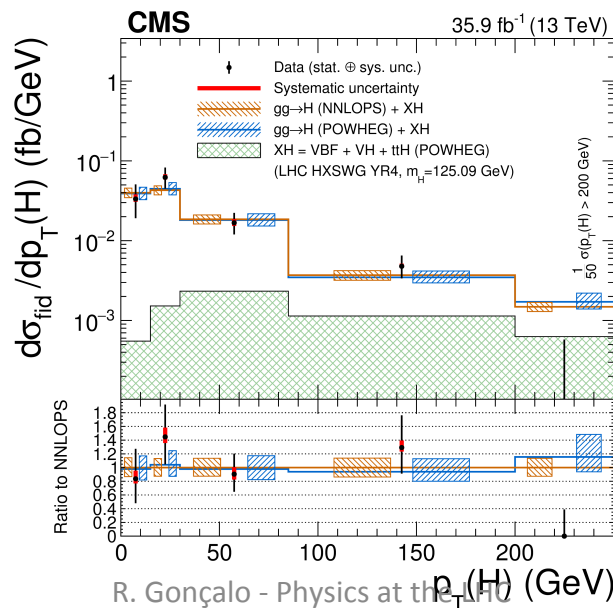
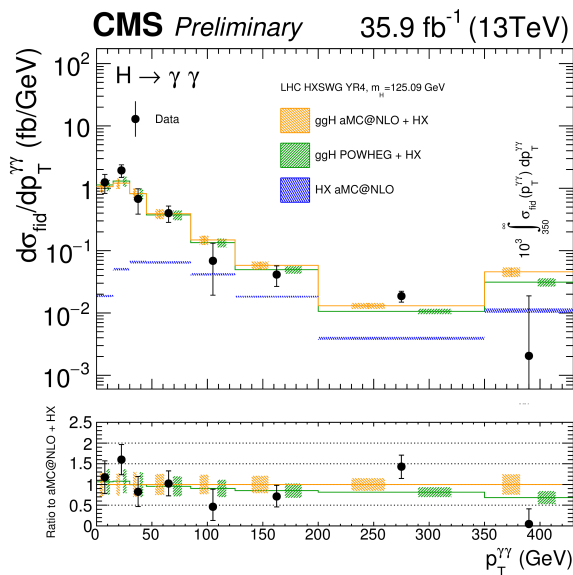

Casting a wider net

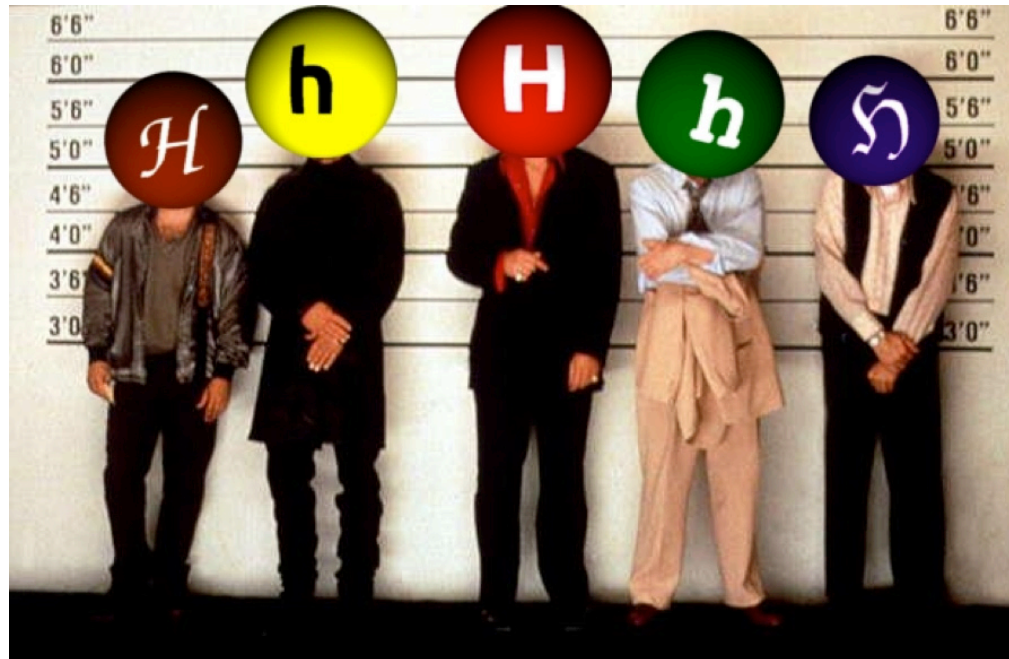

Additional Higgs bosons?

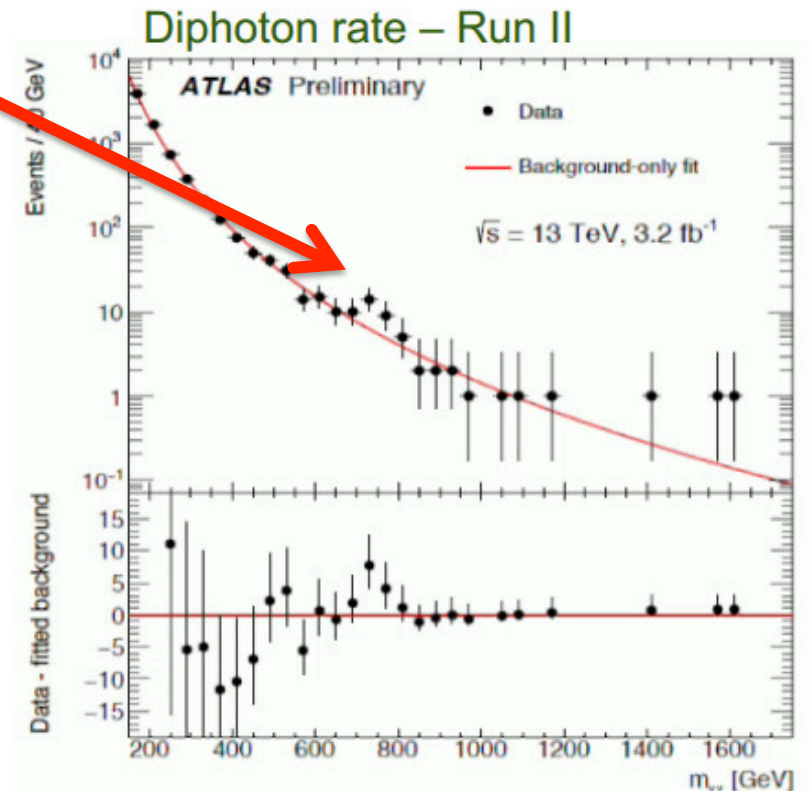
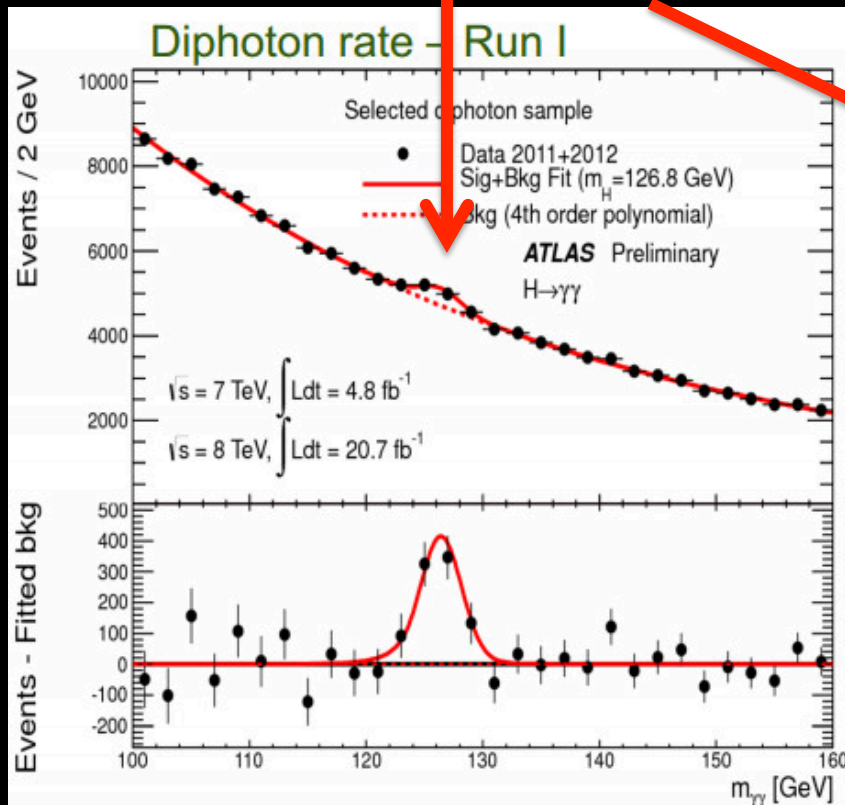

Higgs + Dark Matter

- Used 79.8 fb^{-1} of 13 TeV data
 - High E_T^{miss} ($>150 \text{ GeV}$) and b-tagging to suppress backgrounds
 - Reconstruct b-jets as 2 small jets or merged variable-radius (VR) track jets
- Signal benchmark: Type-II 2HDM + $U(1)_{Z'}$ symmetry (Z'-2HDM)
- Main backgrounds: tt, W/Z+jets
- Excluded region in $m_A - m_{Z'}$ plane

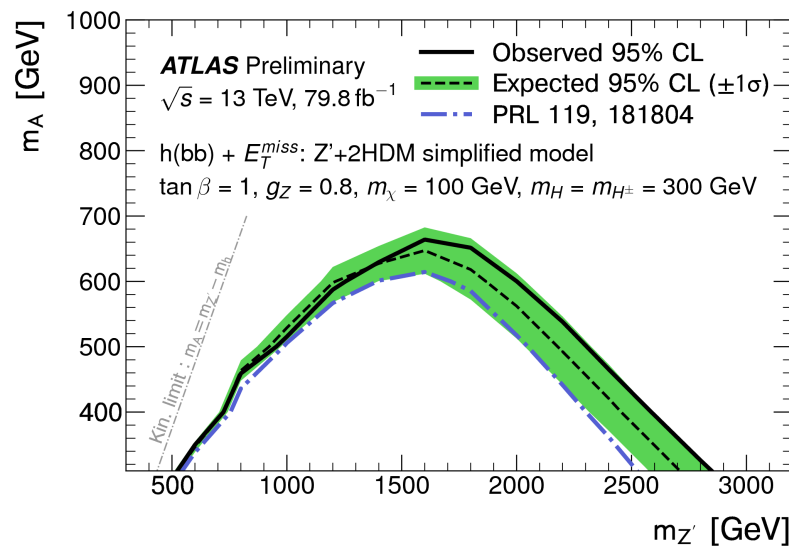
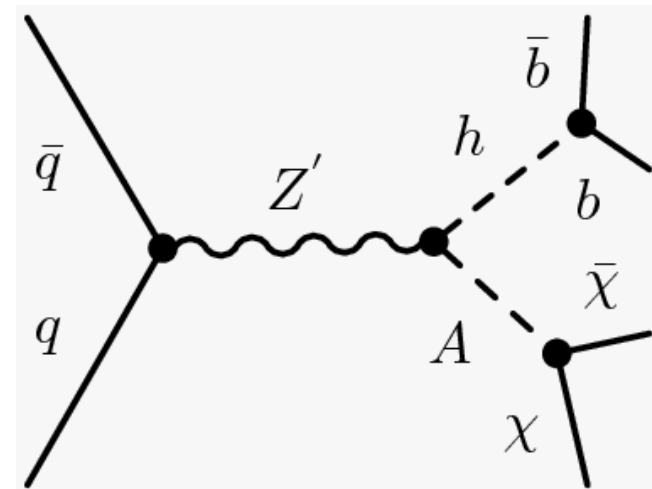

Charged Higgs: $H^+ \rightarrow tb$

- Explored single-lepton and dilepton $t\bar{t}$ final states
 - In range m_{H^+} : 200 – 2000 GeV
- 36.1 fb^{-1} of 13 TeV data
- Events categories: N_{jets} and $N_{\text{b-tags}}$
 - Allow to constrain backgrounds in simultaneous fit
- BDTs trained in signal regions
 - Separate signal and background for 18 mass points
 - Matrix method used in single-lepton channel
- Extracted limits on $\sigma \times \text{BR}$ and on $m_{H^+} - \tan \beta$ plane for two MSSM scenarios

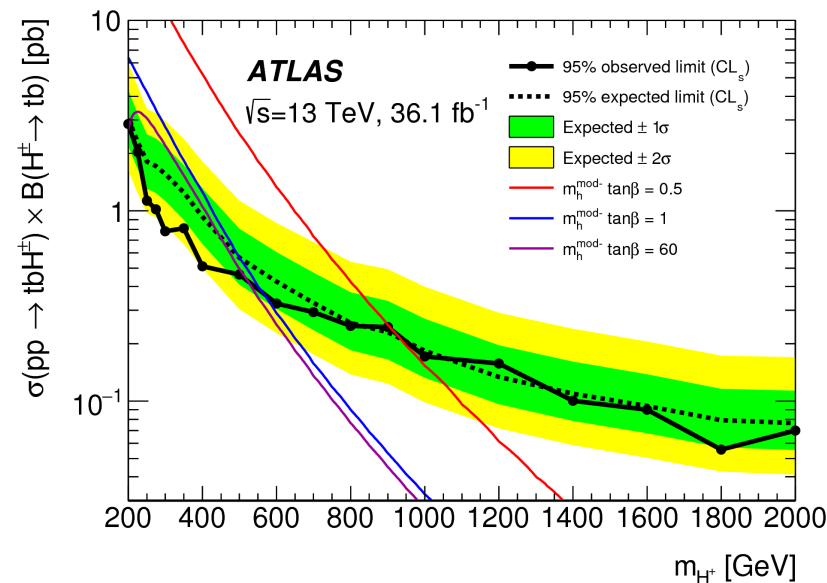
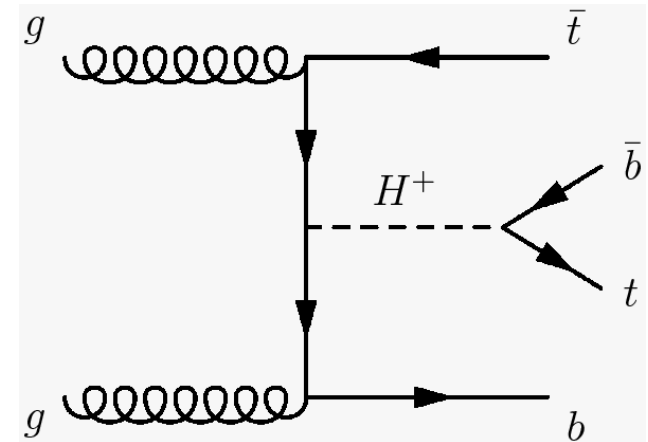

Triple Higgs coupling

- The triple Higgs coupling λ_{HHH} can be probed through di-Higgs production
- Very suppressed in SM!
 - Negative interference between LO diagrams
 - Cross section 1500x less than ggF
- Wide range of decay BR and channel purity
- bb $\tau\tau$ analysis:
 - Used 36 fb⁻¹ of 13 TeV data
 - Final state BR(bb $\tau\tau$)=7%
 - Non-Resonant 95% CL limit:
 - $\mu < 12.7$ observed (**14.8 expected**)
- Combination: at $\approx 10 \times$ SM sensitivity**
 - with 3% of the HL-LHC luminosity analyzed

$$V(\phi) = \mu^2 \phi^\dagger \phi + \lambda (\phi^\dagger \phi)^2$$

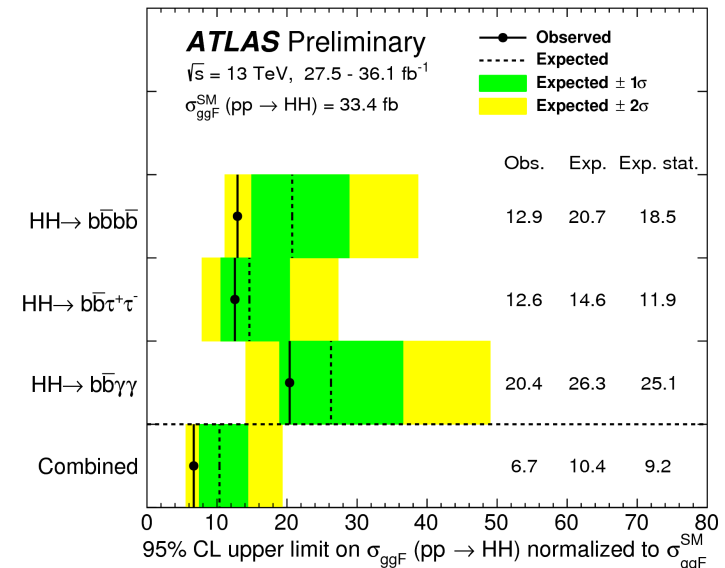
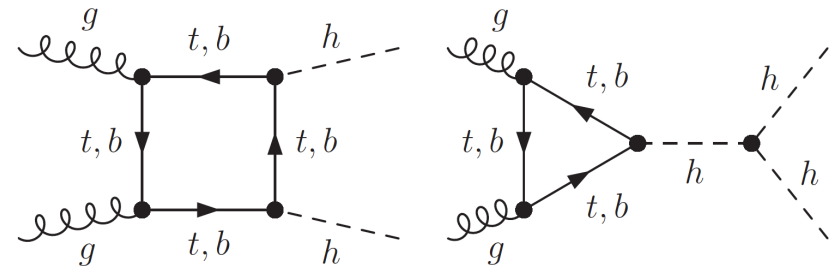

Di-Higgs combination plot [here](#)

01.04.20

R. Gonçalo - Physics at the LHC

72

Implications for 2HDM

- $H(125)$ assumed to be light CP-even neutral scalar h in 2HDM
- h production and decay same as for SM Higgs boson

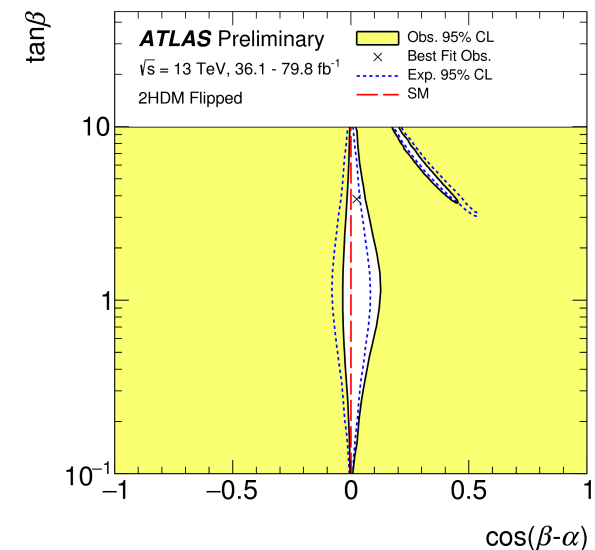
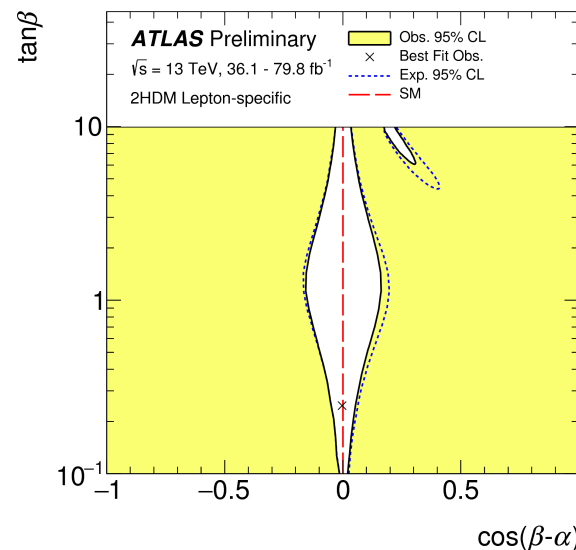
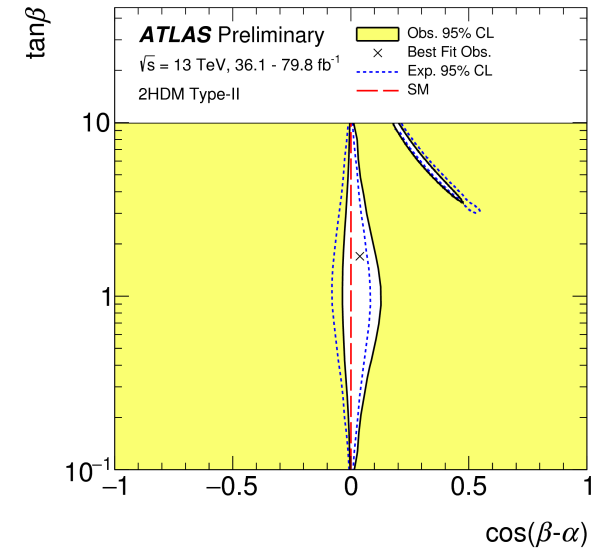
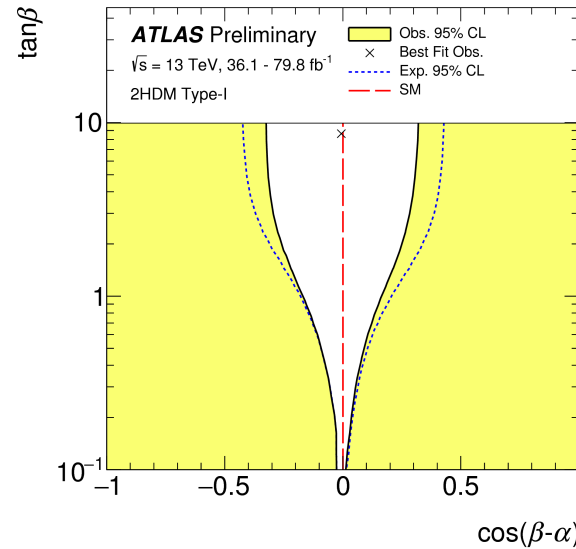

A bit of fun...

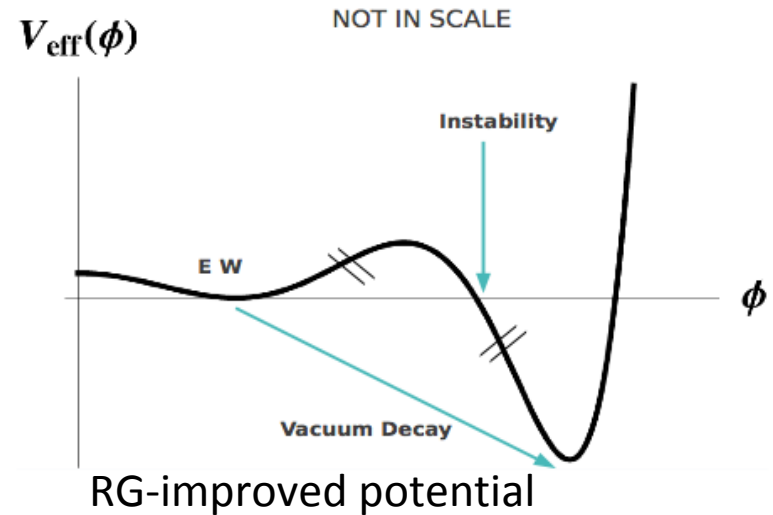
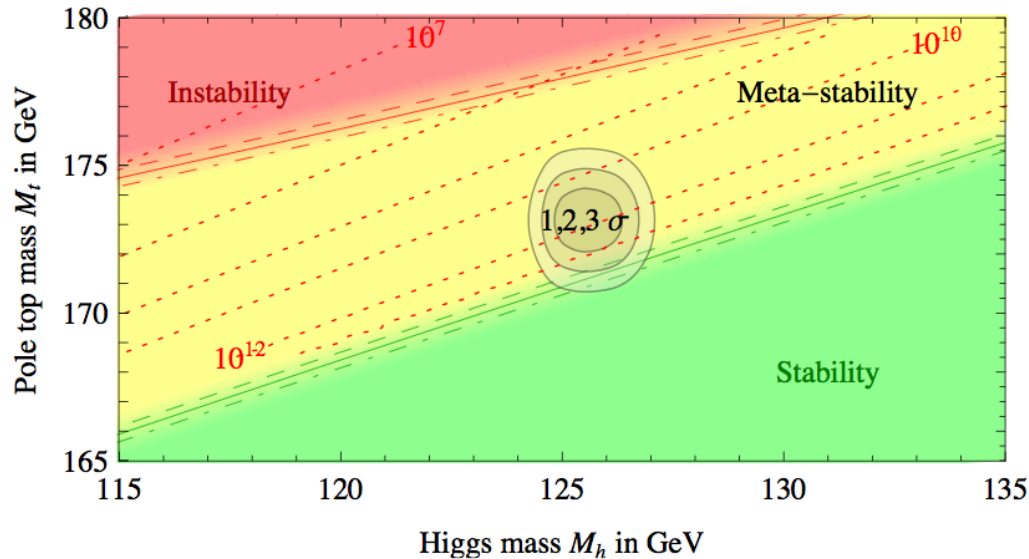

- What if...
 - At higher orders, Higgs potential doesn't have to be stable
 - Depending on m_t and m_H second minimum can be lower than EW minimum \Rightarrow tunneling between EW vacuum and true vacuum?!
- “For a narrow band of values of the top quark and Higgs boson masses, the Standard Model Higgs potential develops a shallow local minimum at energies of about 10^{16} GeV, where primordial inflation could have started in a cold metastable state”, I. Masina, arXiv:1403.5244 [astro-ph.CO]
 - See also: V. Brachina, Moriond 2014 (Phys.Rev.Lett.111, 241801 (2013)), G. Degraasi et al, arXiv:1205.6497v2; R.Contino, Workshop sulla fisica p-p a LHC, 2013

The universe seems to live near a critical condition

JHEP 1208 (2012) 098

Why?!

Explained by underlying theory?

Anthropic principle?

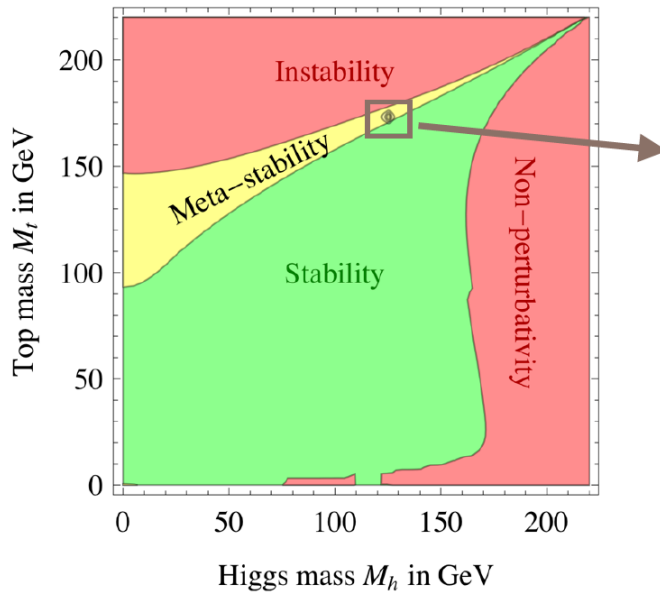
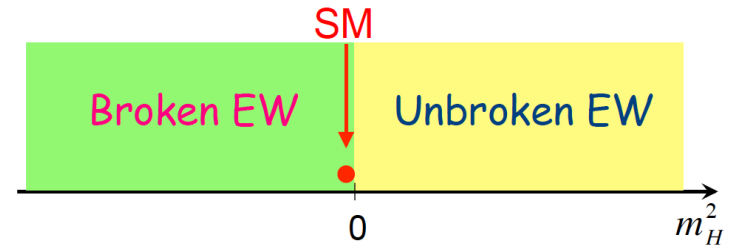

Local News

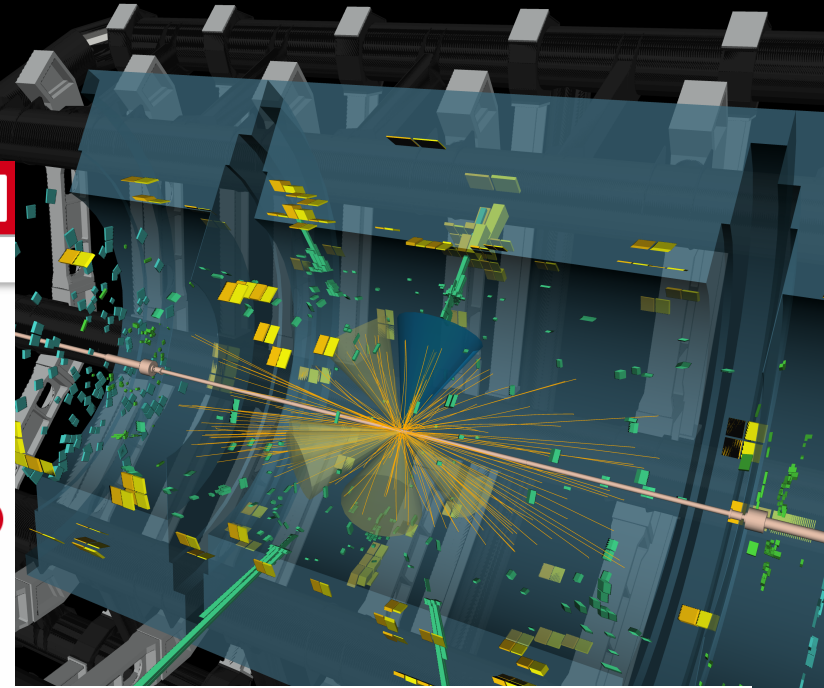

☰ 🔍 📖 **P** P2 ÍPSILON CULTO FUGAS P3 CINECARTAZ Entrar Assine já

CIÊNCIA > ESPAÇO MEDICINA ECOSFERA

FÍSICA DE PARTÍCULAS

Bosão de Higgs revela que relação mantém com o quark *top*

Investigadores portugueses participaram na descoberta.

PÚBLICO · 4 de Junho de 2018, 19:42

418 PARTILHAS

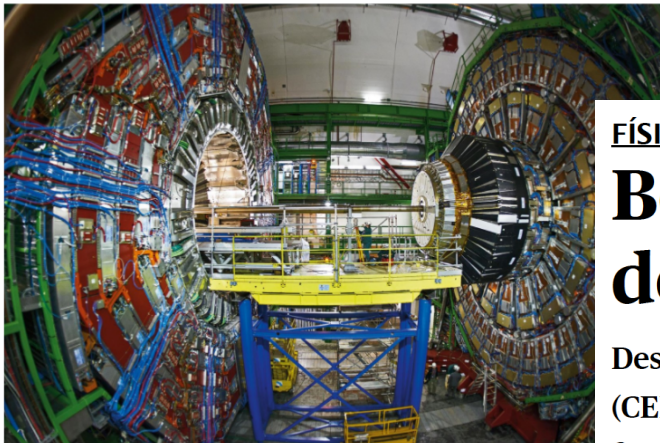

O detector CMS no grande acelerador de partículas LHC, em Genebra

FÍSICA DE PARTÍCULAS

Bosão de Higgs visto (finalmente) a desintegrar-se em quarks *bottom*

Descoberta anunciada no Laboratório Europeu de Física de Partículas (CERN) é um passo fundamental para perceber como o bosão de Higgs faz com que as partículas fundamentais adquiram massa.

PÚBLICO · 28 de Agosto de 2018, 17:47

Observation of $H \rightarrow bb$

- See **CERN seminar last week!** (<https://indico.cern.ch/event/750541/>)
- Largest branching fraction (58.4%) but huge background from heavy flavour production
- Must use associated production: WH/ZH
 - Require 2 b jets + 0 ($Z \rightarrow \nu\nu$), 1 ($W \rightarrow \ell\nu$) or 2 ($Z \rightarrow \ell\ell$) leptons
- Largest backgrounds:
 - Z+heavy flavour (0- and 2-lepton) and tt (1-lepton)
 - Irreducible background from VZ with $Z \rightarrow bb$

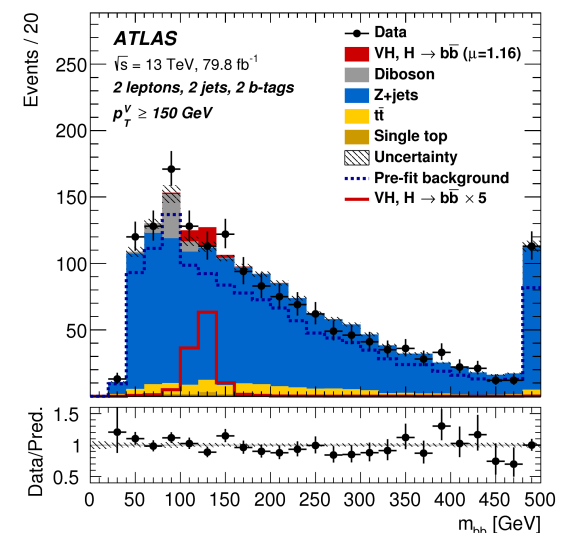
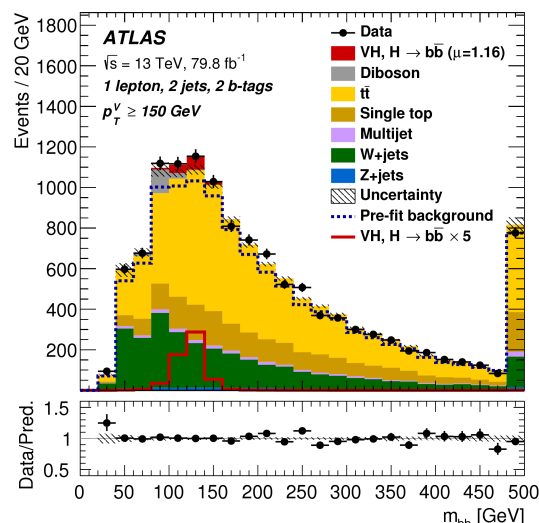
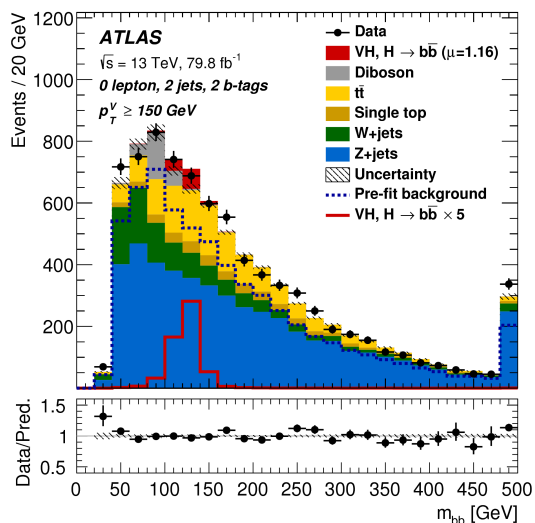

Observation of $H \rightarrow b\bar{b}$

- Harder p_T spectrum for signal than backgrounds
 - Go to high p_T to improve S/B
- Use for event categories:
 - $75 < p_T^V < 150$ GeV (2 ℓ only)
 - $150 < p_T^V < 200$ GeV
 - $p_T^V > 200$ GeV
- Main discriminant variables m_{bb} , p_T^V and ΔR_{bb}
 - m_{bb} resolution extremely important!

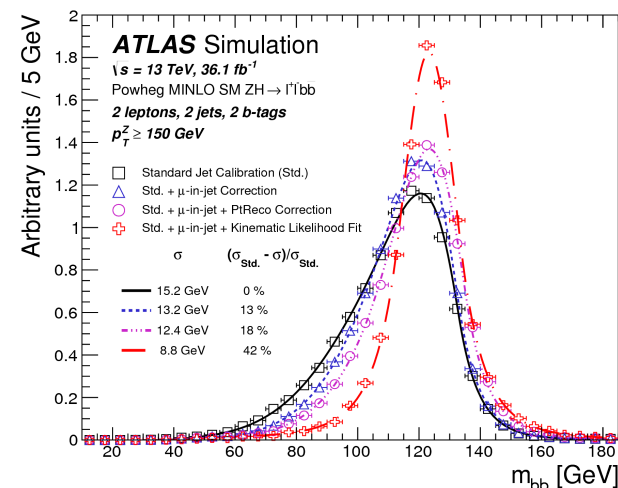
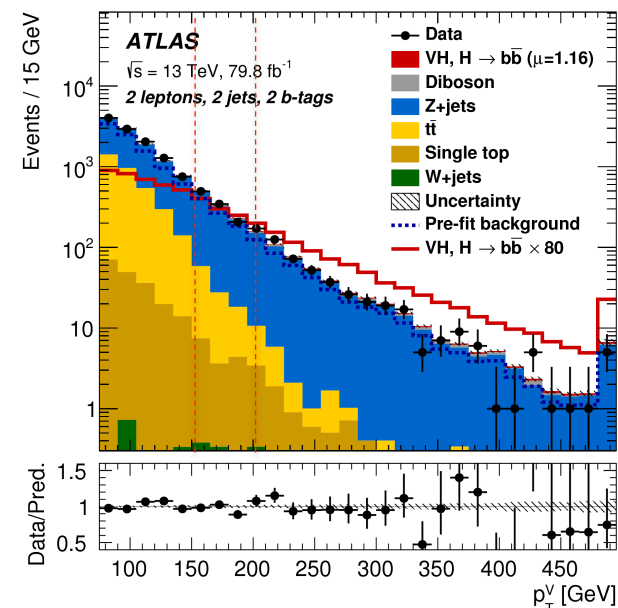

Observation of $H \rightarrow b\bar{b}$

- Run 2:
 - Observed (expected) of 4.9σ (4.3σ)
- Adding Run 1:
 - Observed (expected) of 4.9σ (5.1σ)
- Adding ttH and VBF:
 - Observed (expected) of 5.4σ (5.5σ)
 - **Observation of $H \rightarrow b\bar{b}$ decays**
- Adding $H \rightarrow ZZ$ and $H \rightarrow \gamma\gamma$:
 - Observed (expected) of 5.3σ (4.8σ)
 - **Observation of VH production**

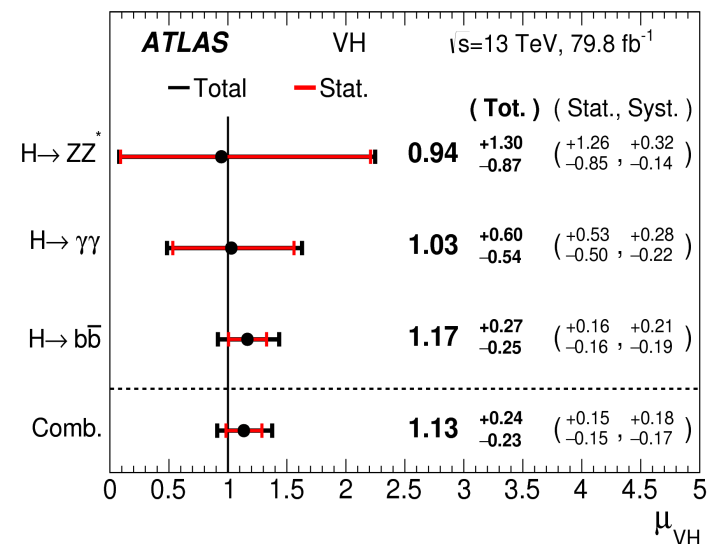
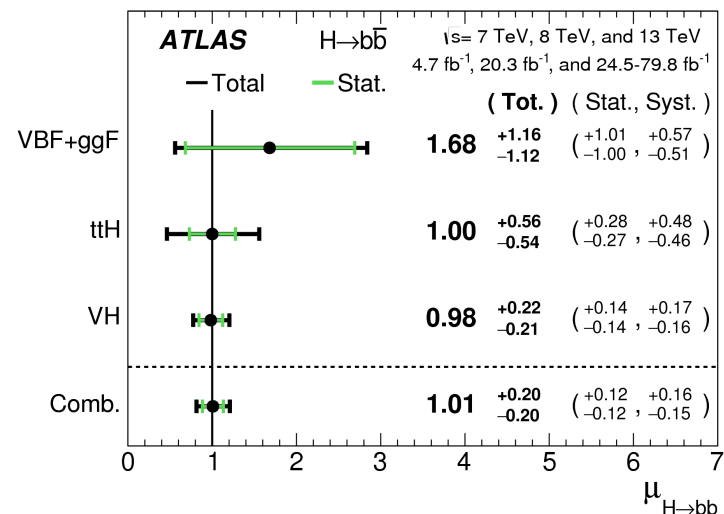

Combination

- Combined $\gamma\gamma$, ZZ, WW, $\tau\tau$, $\mu\mu$ and bb (incl. ttH+tH modes)
 - Up to 79.8 fb^{-1} of $\sqrt{s} = 13 \text{ TeV}$ data
- Combination yields VBF significance 6.5σ (5.3σ expected) **from ATLAS alone**
- **Main production modes (ggF, VBF, VH, ttH) have all been observed!!**
- Good agreement with SM predictions
- Overall signal strength:

$$\mu = 1.13^{+0.09}_{-0.08}$$
- Quantified space for undetectable decays or modified BR (e.g. BSM $H \rightarrow c\bar{c}$)
 - $B_{\text{BSM}} < 0.13$ at 95% CL. (*)

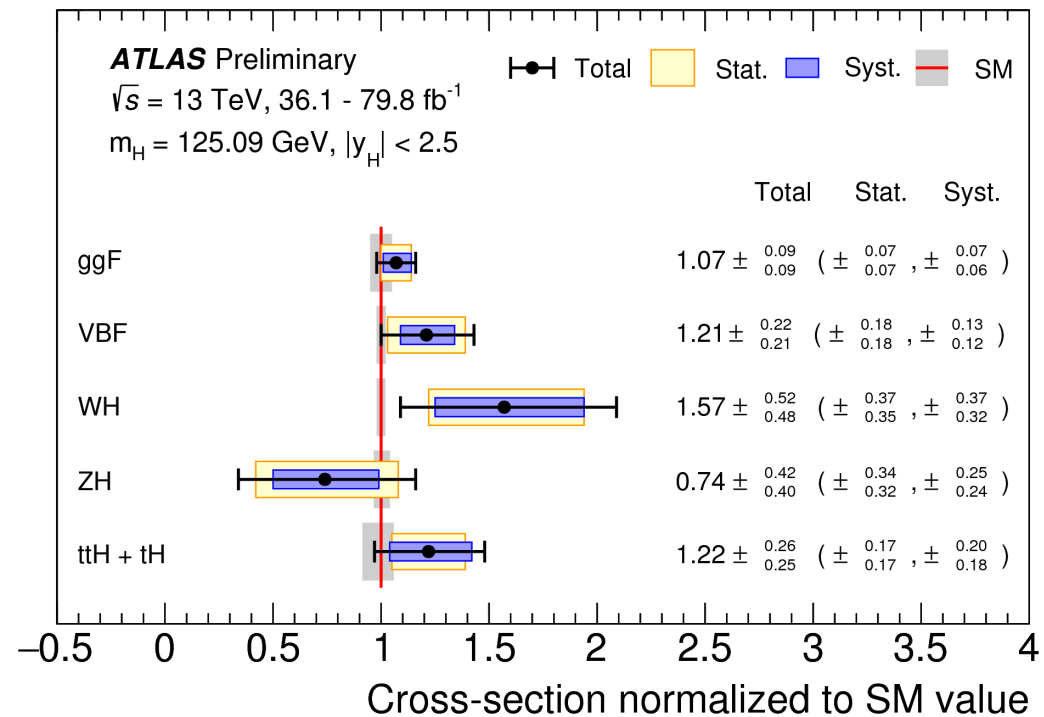

(*) In determination of κ_g and κ_γ - assumption dependent

Observation of $t\bar{t}H$ production

- **Direct** access to top Yukawa coupling
- Experimental tour-de-force!
 - Complex final states
 - Large irreducible backgrounds
 - Small cross sections: $O(0.5)\text{pb}$ @ 13 TeV
- Use all available final states:
 - $H \rightarrow b\bar{b}$: high stats but low purity $BR \approx 58\%$, $S/B \approx 1-6\%$
 - **Multileptons**: $H \rightarrow \tau\tau$, $H \rightarrow WW^*$, $H \rightarrow ZZ^*$ $BR = 30\%$, $S/B = 4-34\%$
 - $H \rightarrow \gamma\gamma$: clean but low stats $BR = 0.23\%$, $S/B = 5-200\%$
 - $H \rightarrow ZZ^* \rightarrow 4\text{lep}$: clean but very low stats $BR = 0.01\%$, $S/B = 50-500\%$

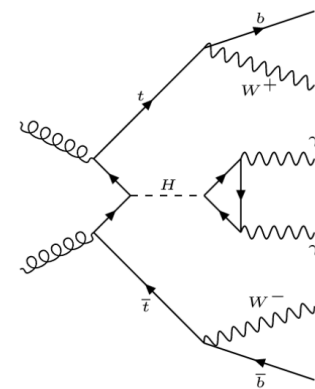
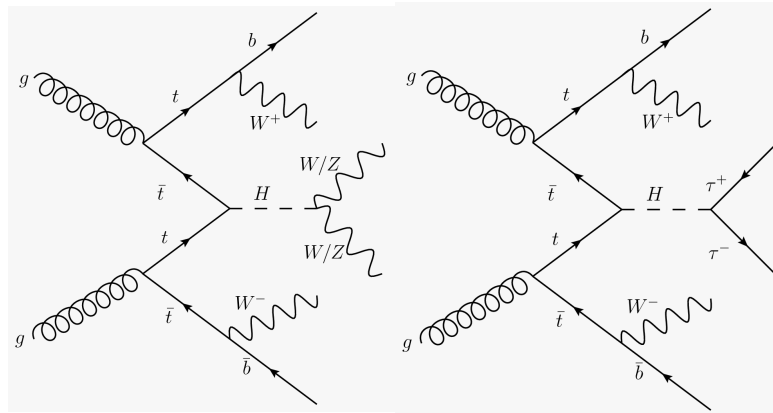
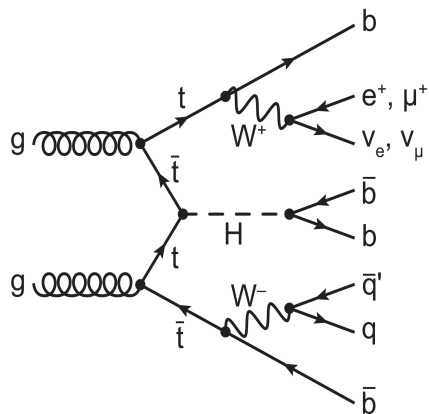

ttH observation: bb and Multileptons

ttH(H→leptons)

- Sensitive to: $H \rightarrow \tau\tau$, $H \rightarrow WW^*$ and $H \rightarrow ZZ^*$
- Backgrounds: ttW/ttZ, non-prompt leptons and jets faking taus
- Main uncertainties: signal modelling, jet energy scale and non-prompt lepton estimate
- **4.1σ observed; 2.8σ expected**

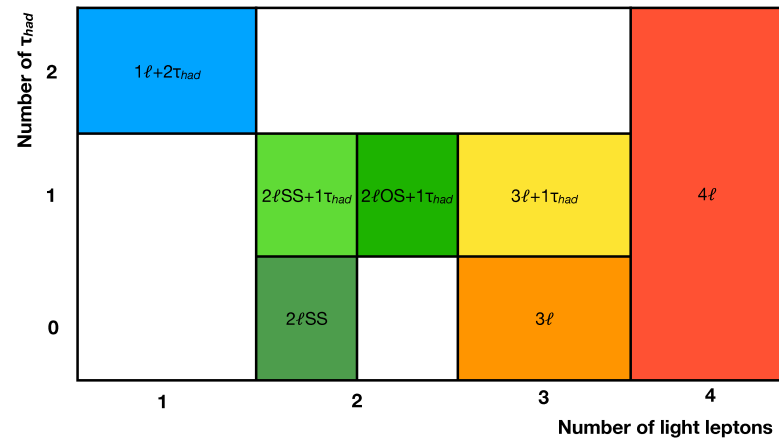

ttH(H→bb):

- Profit from large $H \rightarrow bb$ branching ratio (58.4%)
- But challenging final state: large ttbb irreducible background, theory uncertainties, combinatorics...
- Main uncertainties: tt+heavy flavours, b tagging, jet calibration
- ATLAS: **1.2σ observed; 1.6σ expected**

For **both** channels:

- Intensive use of dedicated machine learning (NN, BDT) and matrix element methods: suppress fake leptons, reconstruct events, flavour tagging, and enhance S/B

ATLAS

$\sqrt{s} = 13$ TeV

Dilepton

$CR_{tt+light}^{3j}$

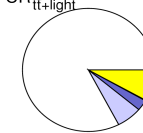

□ $t\bar{t} + \text{light}$
□ $t\bar{t} + \geq 1c$
□ $t\bar{t} + \geq 1b$
□ $t\bar{t} + V$
□ Non- $t\bar{t}$

$CR_{tt+\geq 1b}^{3j}$

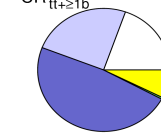

$CR_{tt+light}^{\geq 4j}$

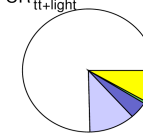

$CR_{tt+\geq 1c}^{\geq 4j}$

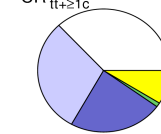

$SR_3^{\geq 4j}$

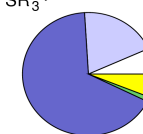

$SR_2^{\geq 4j}$

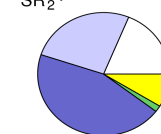

$SR_1^{\geq 4j}$

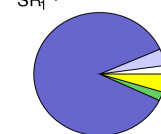

ttH(H → γγ) and Combination

- ttH(H → γγ):
 - New signal categories from BDT discriminant
 - **Sensitivity increased by 50%**

ttH combination: ttH(H → leptons + H → bb + H → γγ)

- Run 2 data from 2015+2016+2017 (γγ/ZZ): 79.8 fb⁻¹
 - **5.2 σ observed, 4.9 σ expected**
- Adding Run 1: **6.3 σ observed, 5.1 σ expected**
- Measured production cross section at 13 TeV:
 - 670 ± 90 (stat.) +110–100 (syst.) fb**

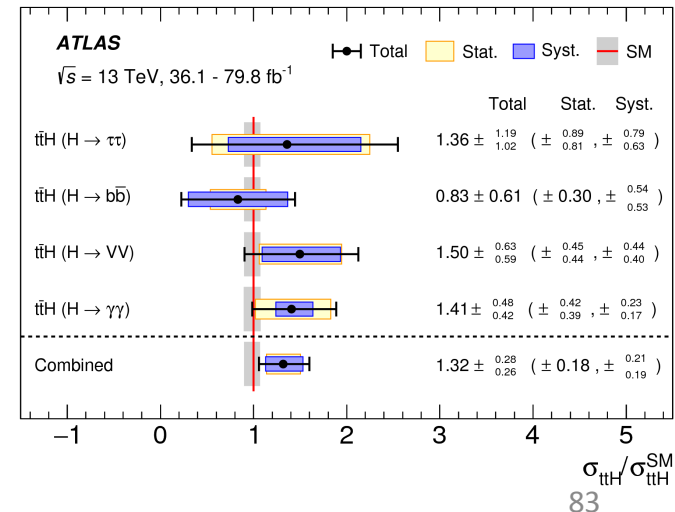
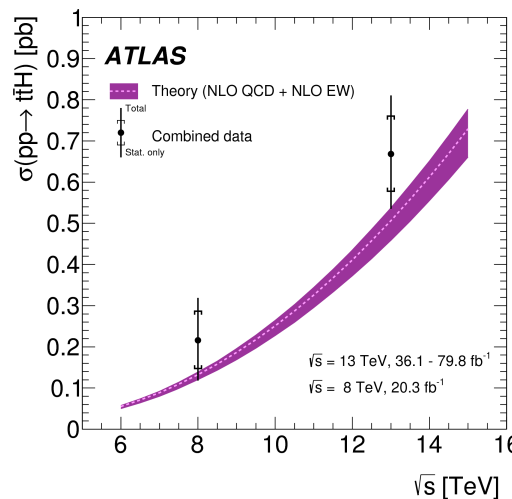
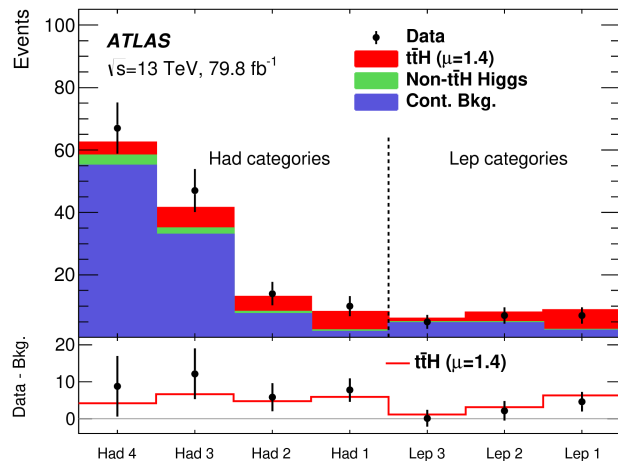
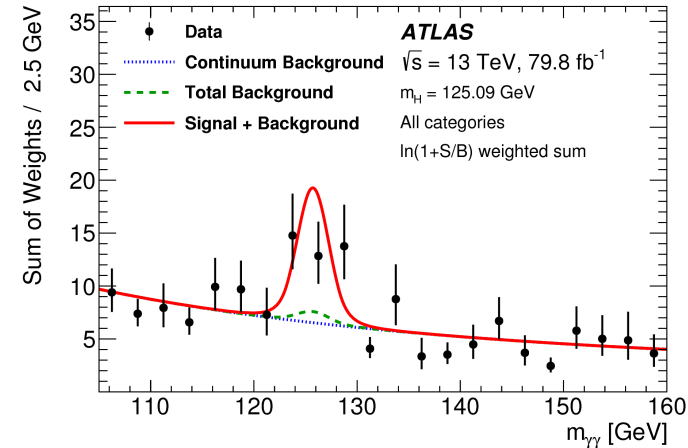

Latest News!!

arXiv:2003.10866 [hep-ex] - last week!

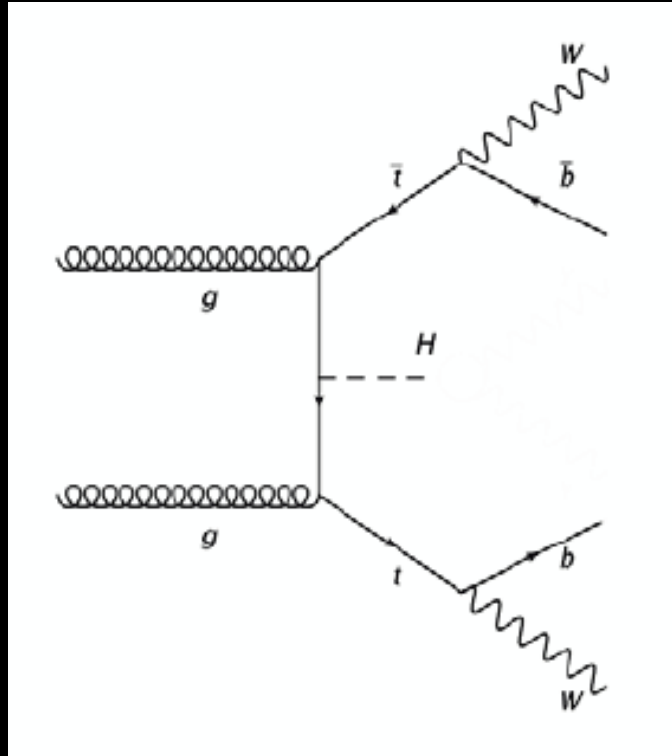

$$f_{CP}^{Htt} = 0.00 \pm 0.33$$

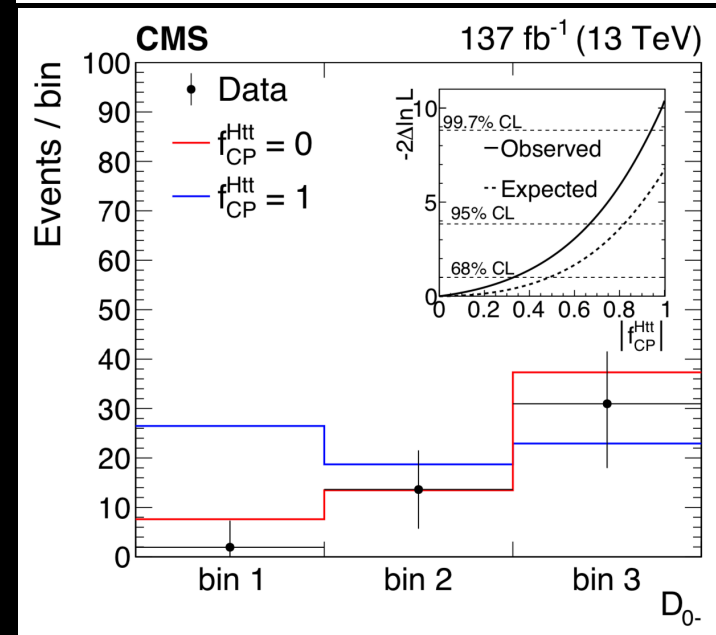
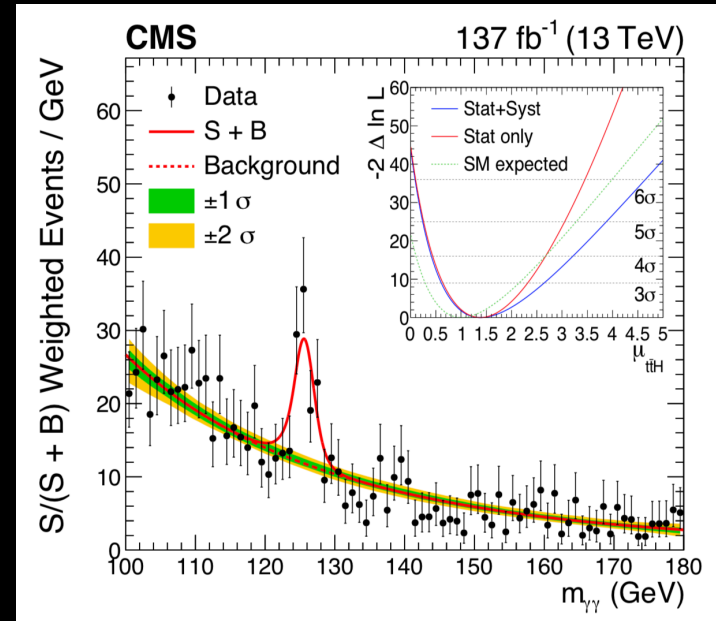

Questions?

Thank you
for your
interest!

jgoncalo@lip.pt

01.04.20

SAY GOD PARTICLE



**ONE MORE
GODDAMN TIME**