

# The Standard Model Higgs and beyond

Michele Gallinaro

*LIP Lisbon*

April 14, 2020

- ✓ The Higgs boson and beyond
- ✓ Charged Higgs
- ✓ BSM Higgs: light pseudo-scalar, non-SM Higgs decay
- ✓ Higgs boson and Dark Matter



$$H \rightarrow ZZ \rightarrow 4e, 4\mu, 2e2\mu$$

- Signal: 4 isolated leptons from same vertex
  - Small background
  - Fully reconstructed, mass resolution  $\sim 1\%$

The golden channel

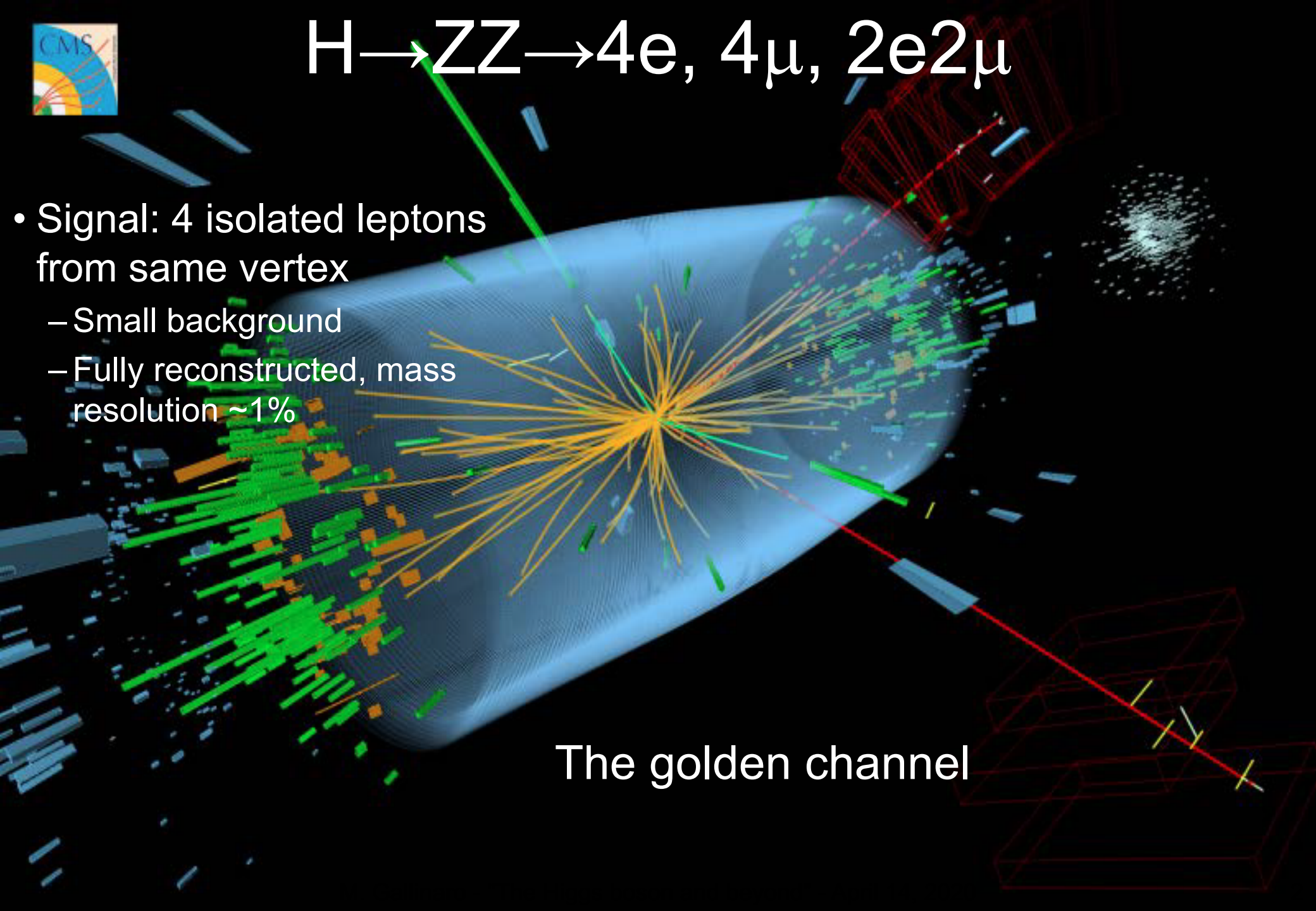

# July 4<sup>th</sup>, 2012: A Higgs boson

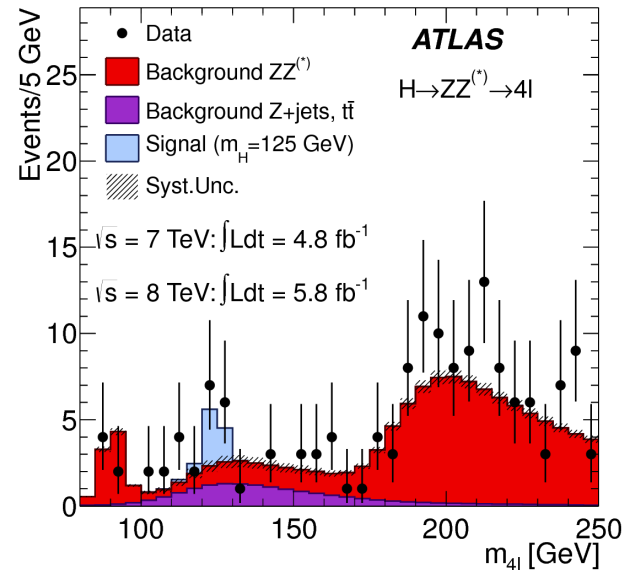
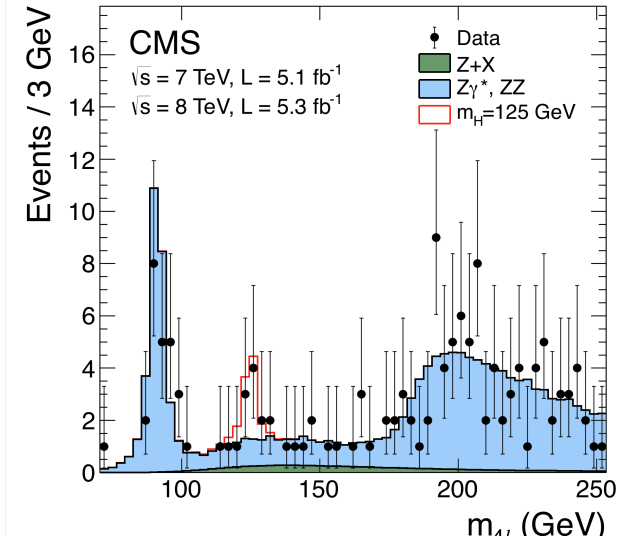
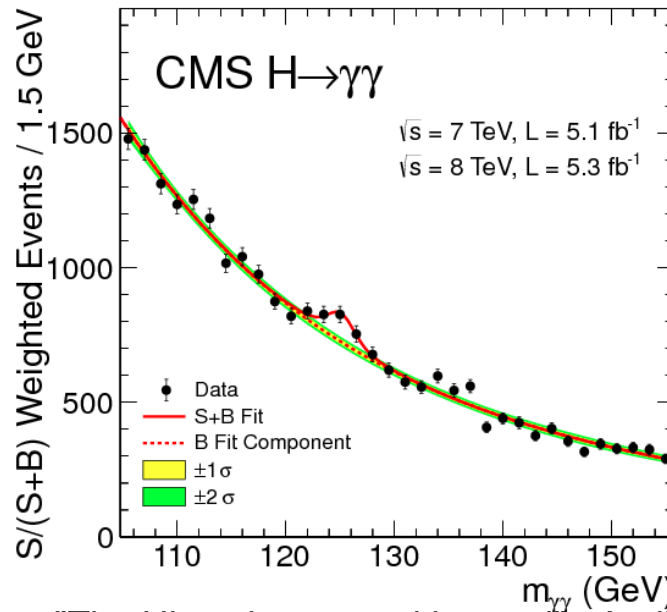
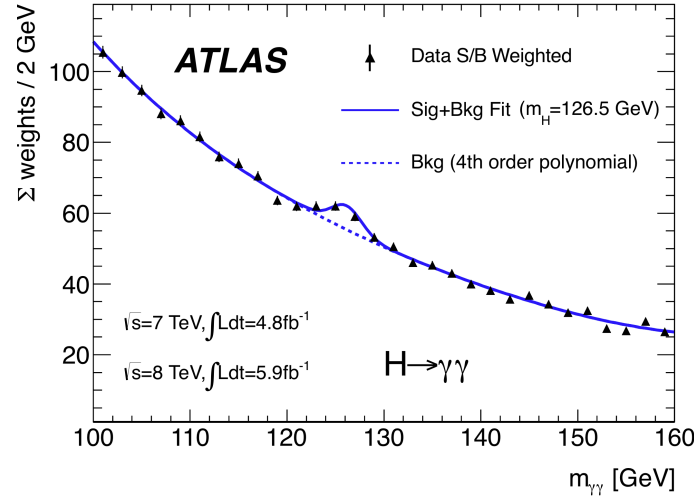
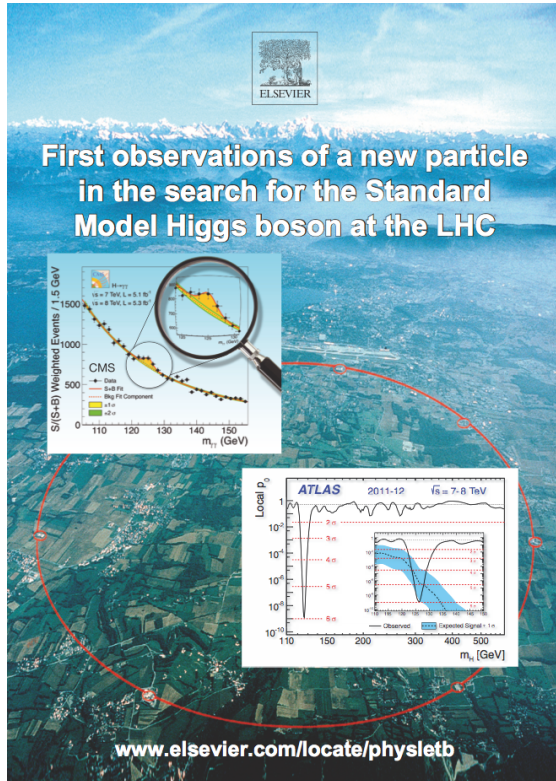

# Higgs and ZZ

CMS-HIG-19-001, CMS-SMP-19-001

- Study of SM ZZ production, and Higgs decay to ZZ
  - ~98% of Run2 data
- SM cross section measured with 3% precision

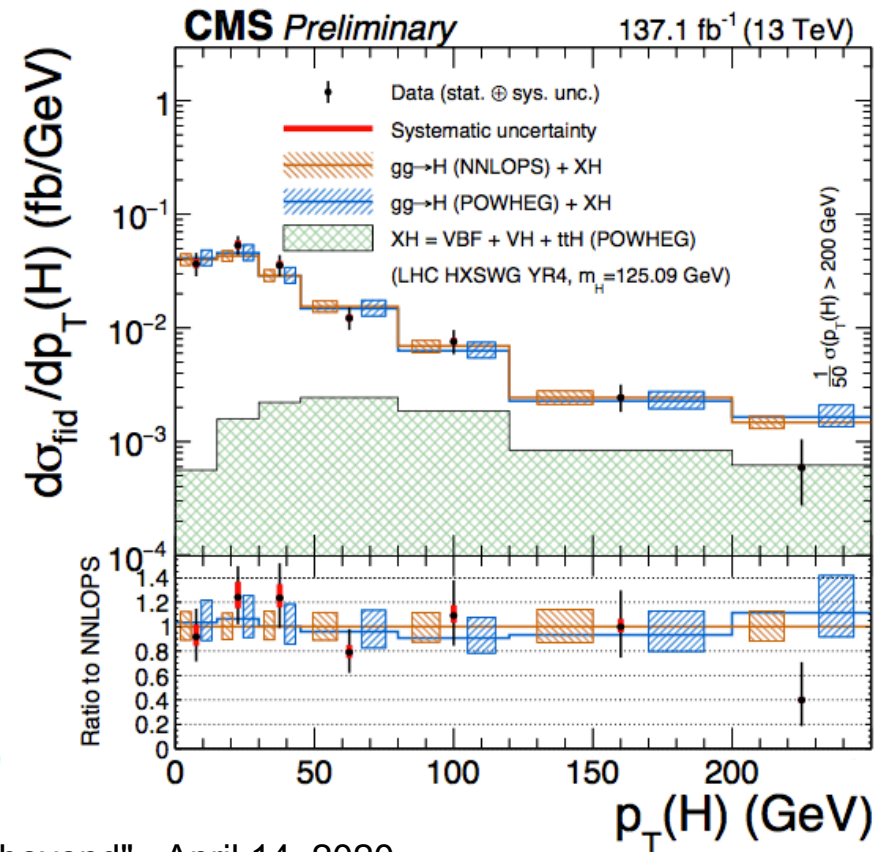
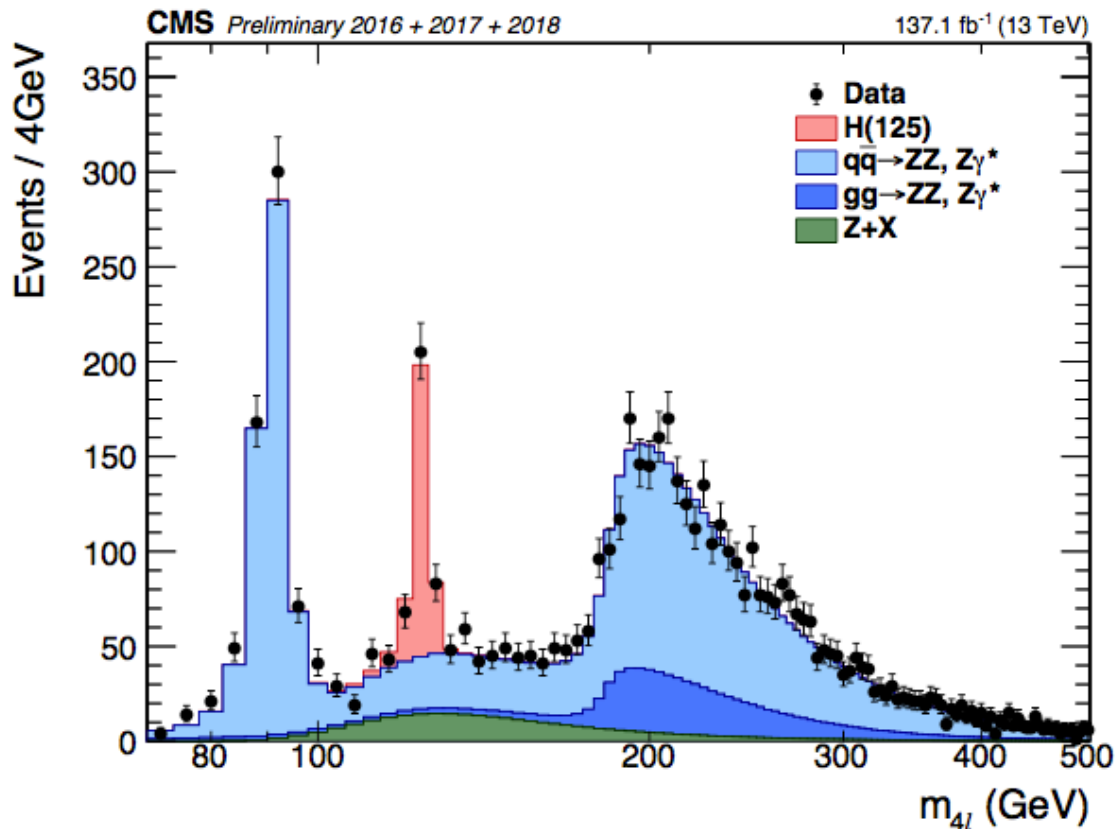

# Low mass-resolution channels

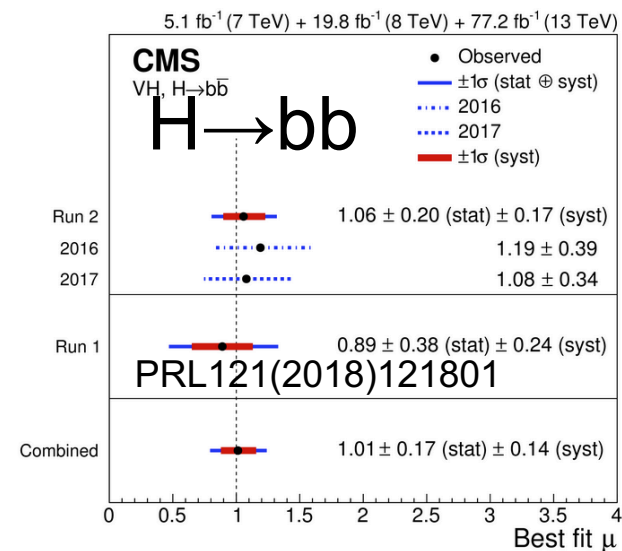
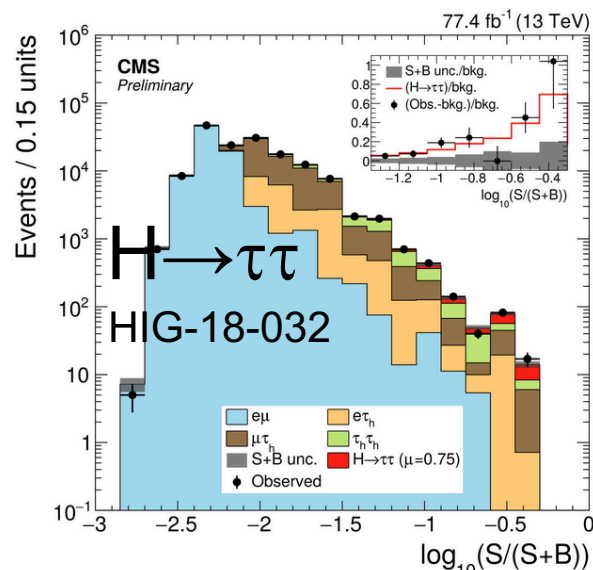
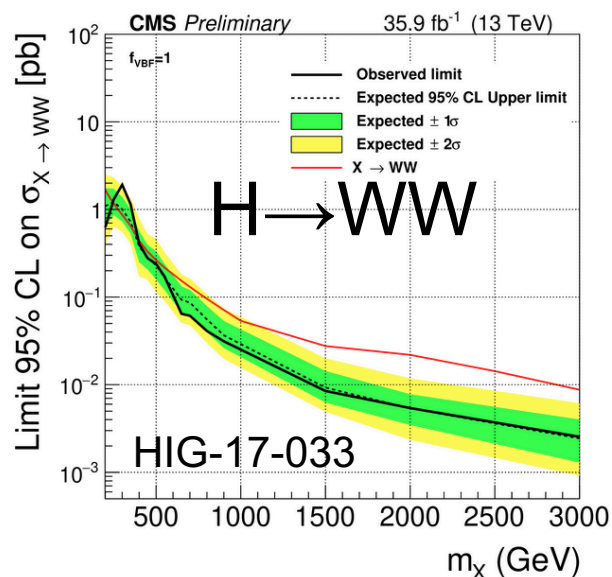
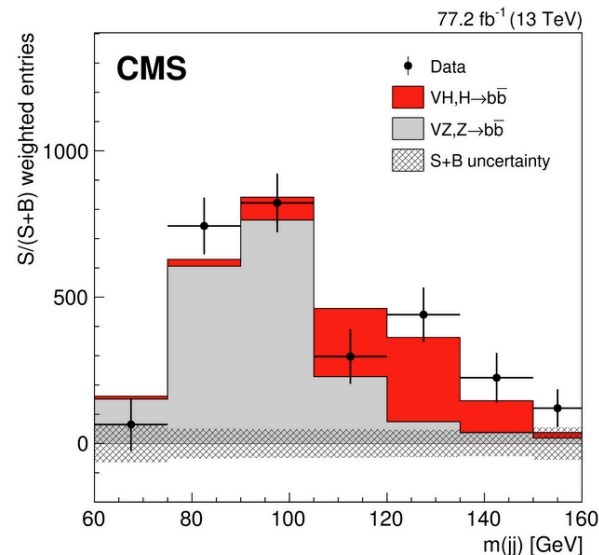
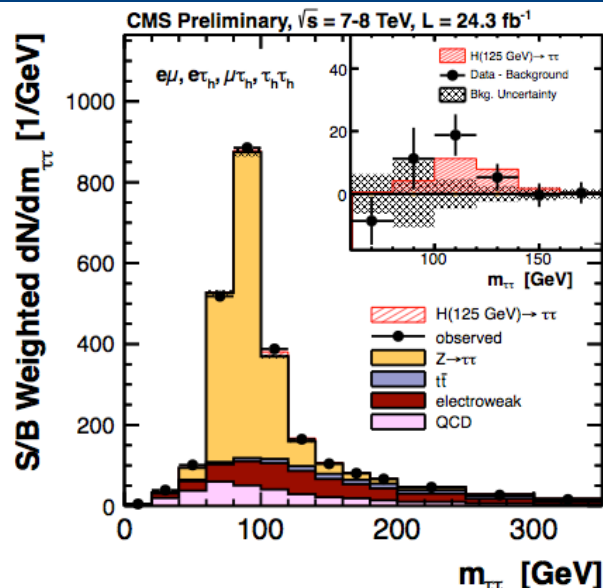
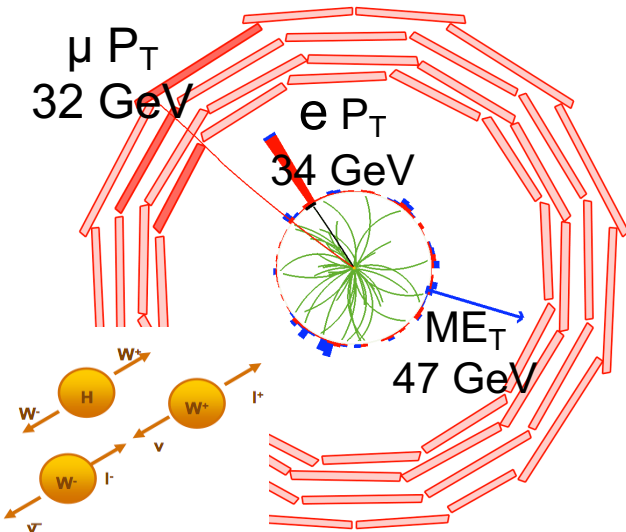

# Couplings: individual channels

EPJC 75(2015)212, arXiv:1507.04548, arXiv:1606.02266

Results based on the full  
Run 1 data samples

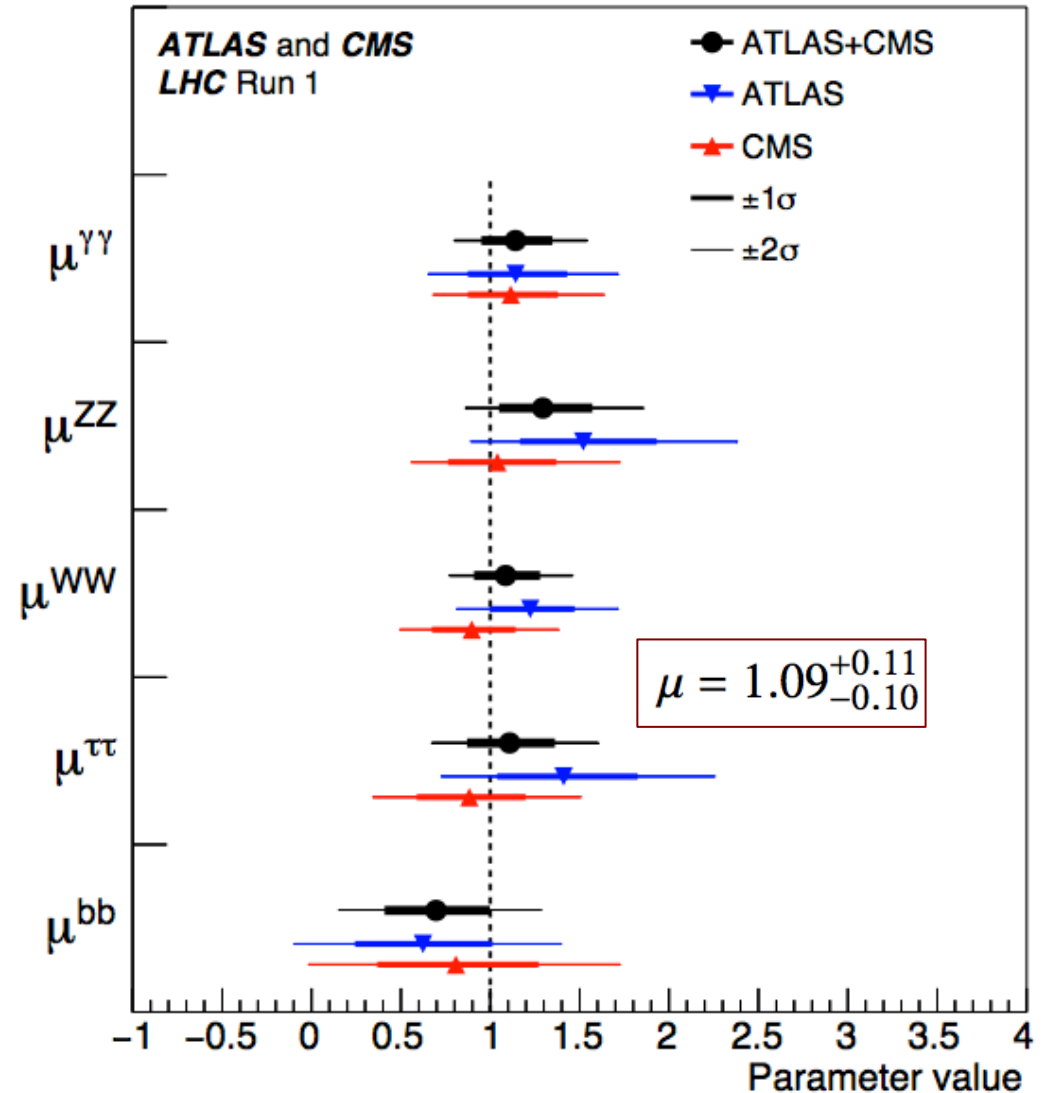

# Rare decays: $H \rightarrow \mu\mu, c\bar{c}$

PRL122(2018)021801, PRL119(2017)051802

## Study couplings to 2<sup>nd</sup> generation

- $H \rightarrow \mu\mu$ 
  - Most sensitive category is VBF channel
  - Obs.(exp.):  $0.9 \sigma$  ( $1.0\sigma$ )
- $H \rightarrow c\bar{c}$ 
  - Low cross section, need c-tagging
  - Use resolved (2jets) and merged (1jet),
  - Use ML and jet substructure for tagging and classification
  - Validate using VZ production:  $\mu = 0.55 \pm 0.85$
  - Obs (exp) Upper Limit:  $\mu = 70$  (37) @95% CL

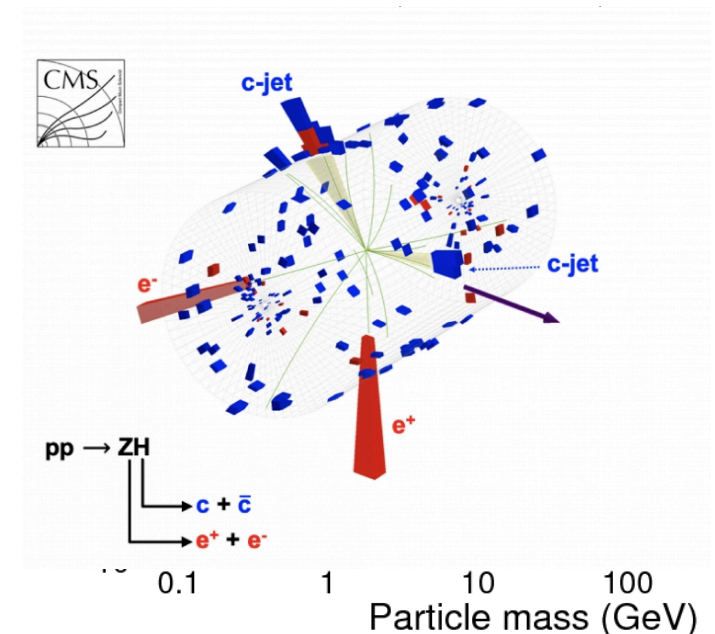
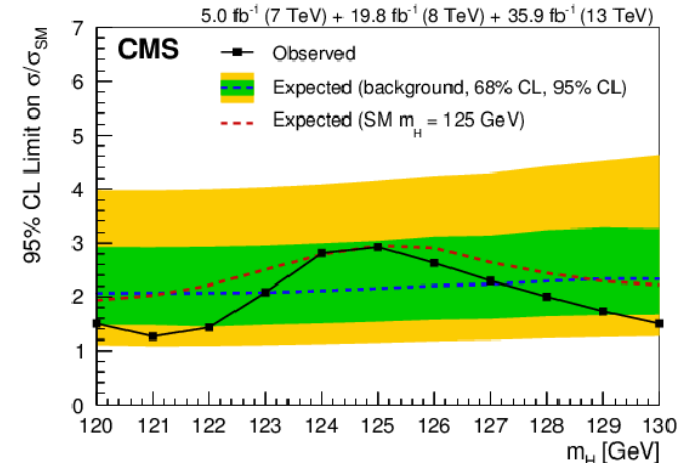

# Search for SM $H \rightarrow \mu\mu$

PRL119(2017)051802, arXiv:1807.06325

- Search based on BDT discriminant
  - Event categories based on BDT score
- Weighted sum of individual fits to each category
- Signal starting to appear in the data
- Signal strength:  $\mu < 2.9$  (2.2) obs. (exp.)

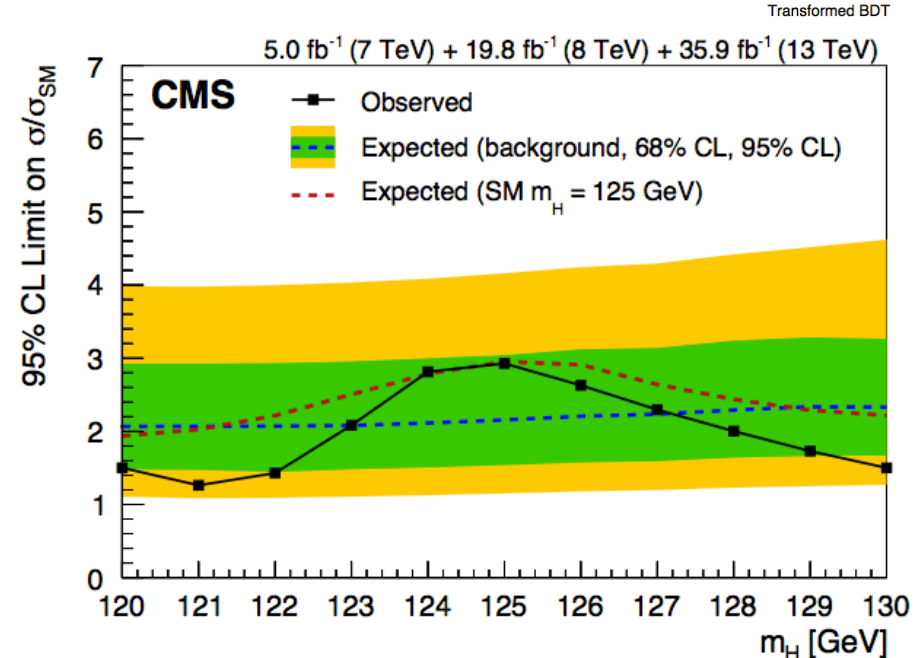
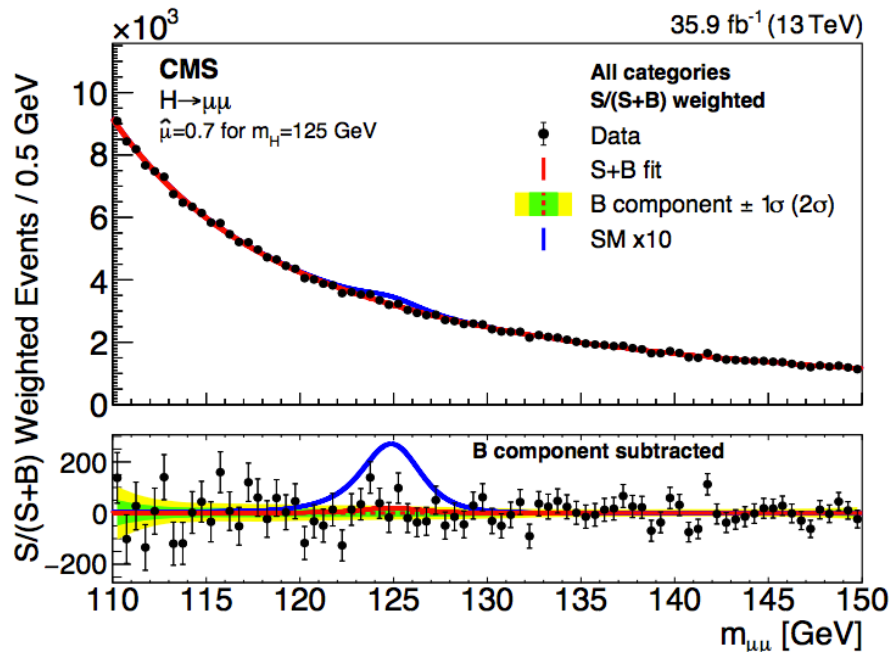
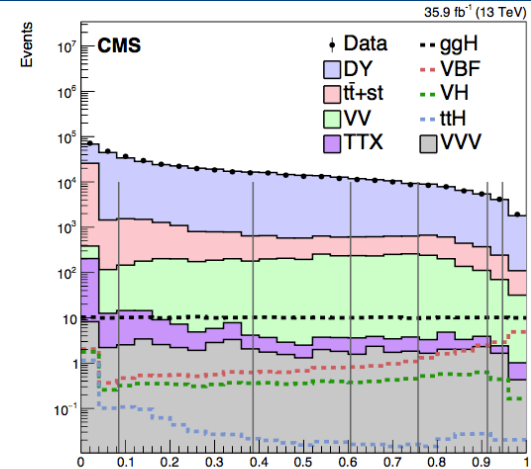



# Search for rare decays

PLB 726(2013)587, arXiv:1507.03031, HIG-15-012, PRL 114(2015)121801, ATLAS-CONF-2016-041, ATLAS-CONF-2017-014

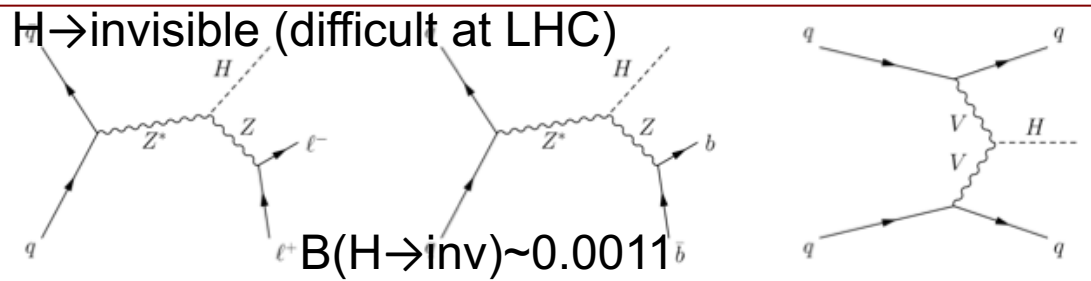
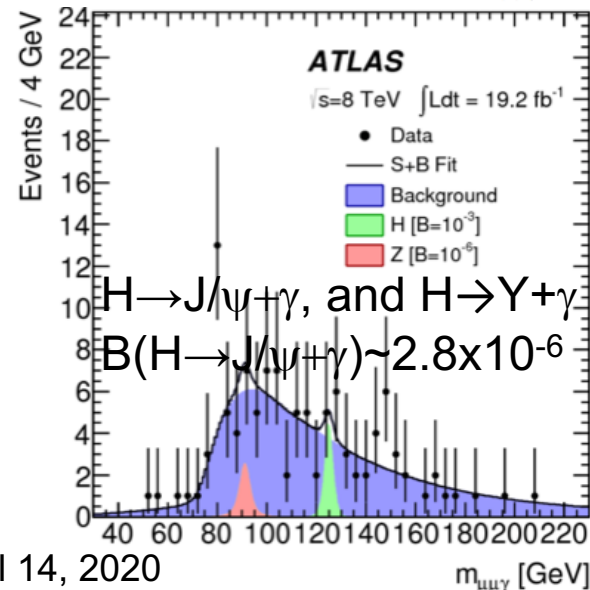
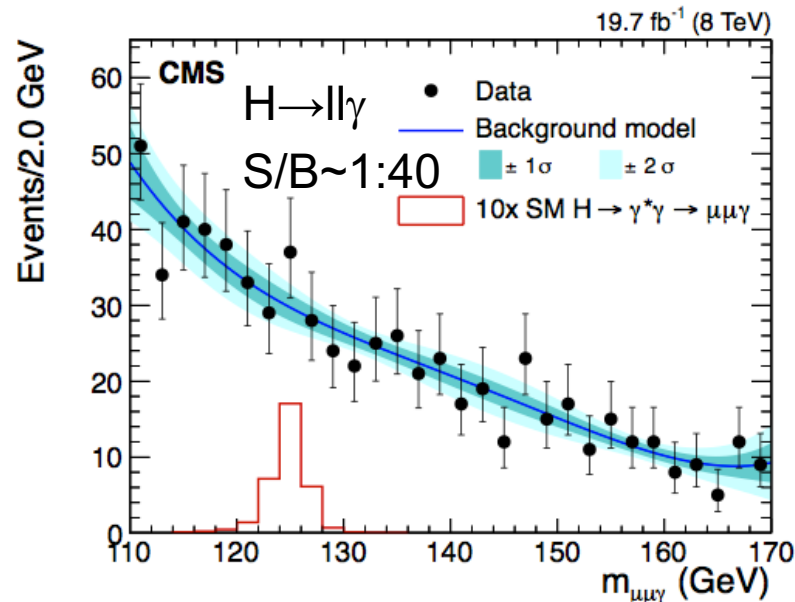
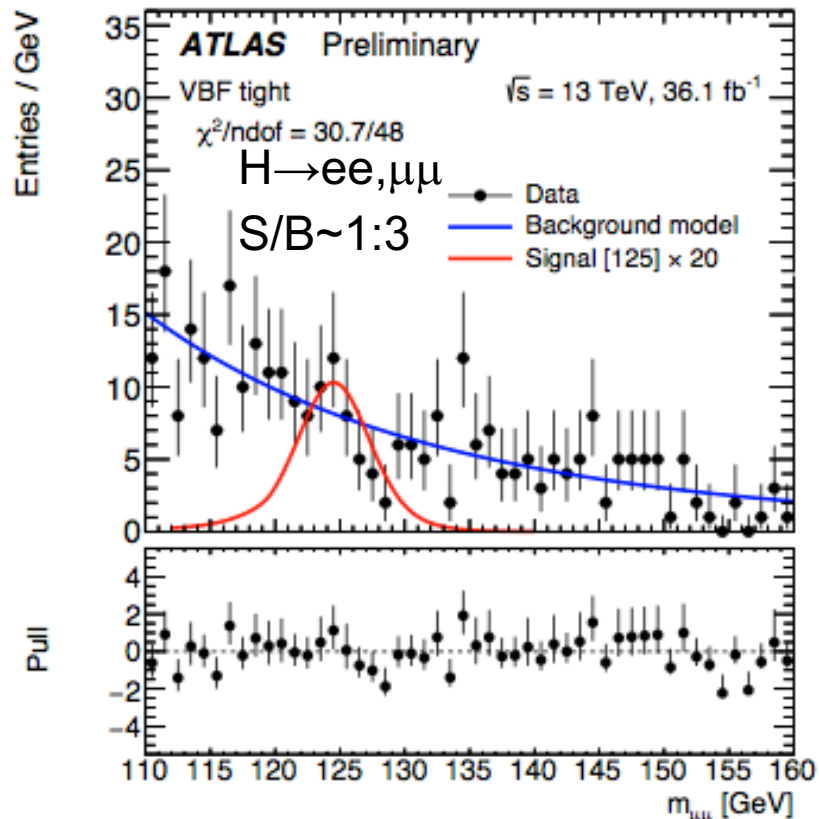

# Combined Higgs measurements

- A wide range of production and decay modes are accessible
- Important to establish unambiguous observation ( $>5\sigma$  significance) of these processes on the way to precision tests of the couplings
- Uncertainties on theoretical predictions also important (in some cases, already comparable to experimental uncertainties)

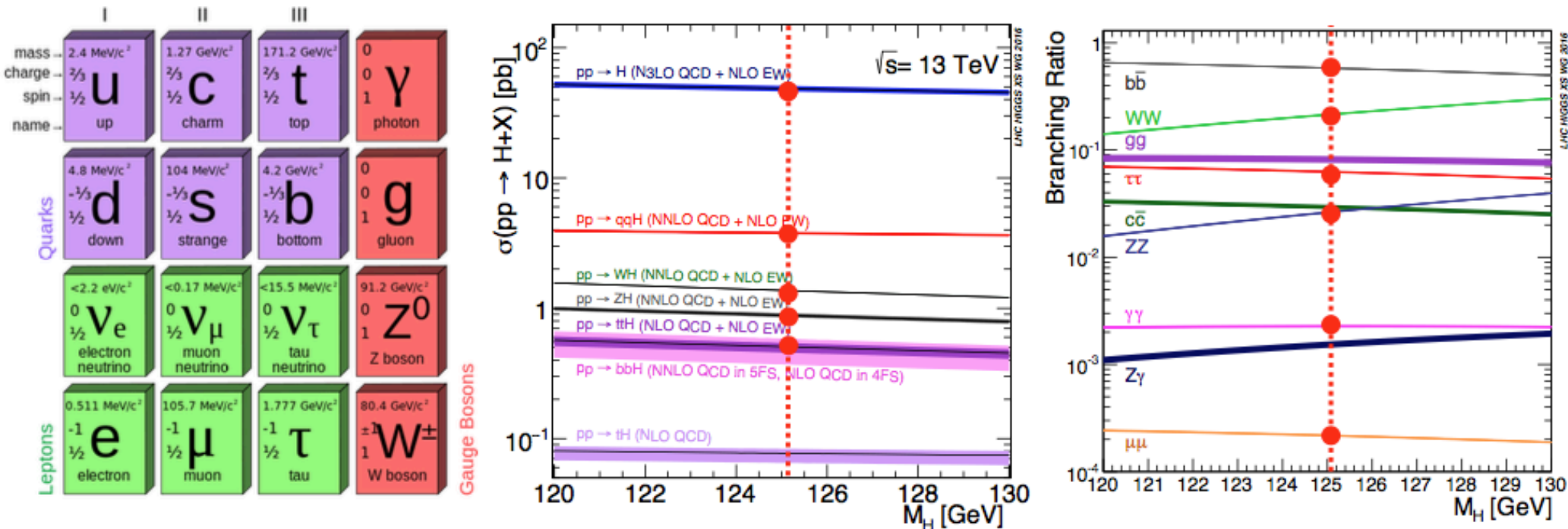

# ttH production: Invisible decays

arXiv:1809.05937

## ttH → invisible

- Search for invisible decays in VBF
- Select large MET and 2-jet events with large  $\Delta\eta(jj)$

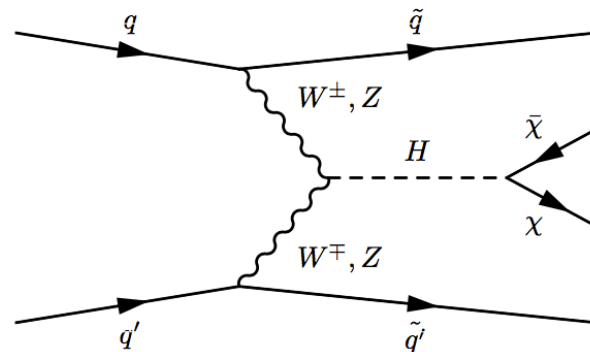

- Fit to dijet invariant mass distributions
- Combination of  $ggH$ ,  $V(jj)H$ , and  $Z(\ell\ell)H$  production modes
- Upper limits: 0,19@95%CL (0,15 exp.)

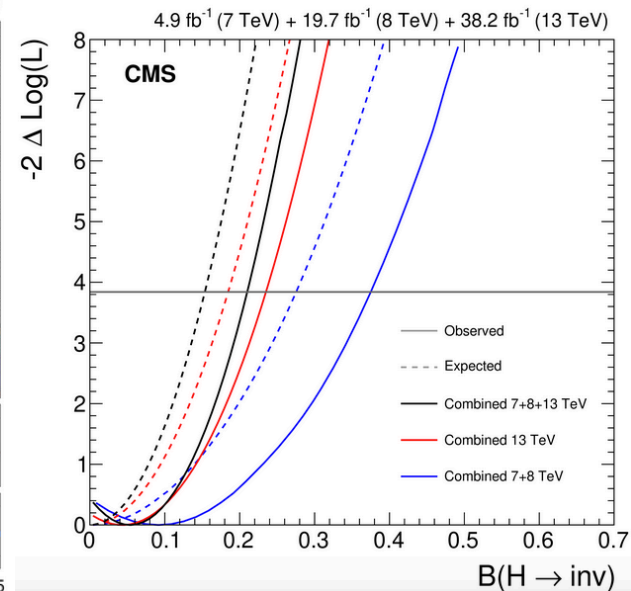
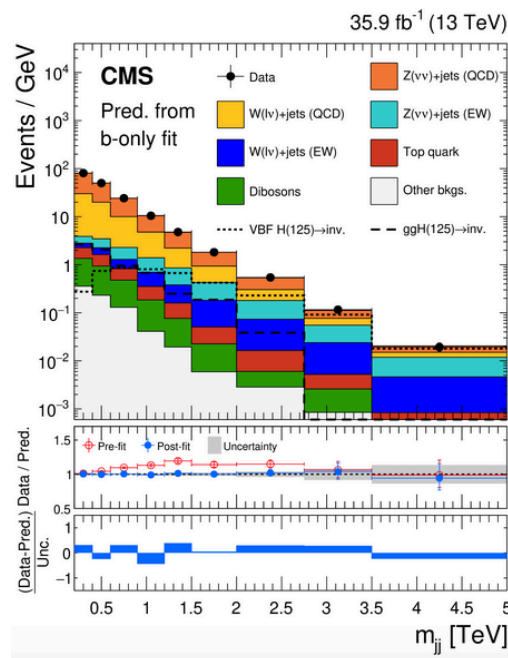

# Higgs and the SM

- SM is a successful theory
- Nothing prevents the SM to survive up to the Planck scale. However, it is **unnatural**.
- Virtual particles in quantum loops contribute to the Higgs mechanism
  - contributions grow with  $\Lambda$  (upper scale validity of the SM)
  - Higgs mass depends quadratically on  $\Lambda$ :  $m^2 = m_0^2 + g^2\Lambda^2$
- Miraculous cancellations are needed to keep  $m_H < 1\text{TeV}$
- Is there a symmetry that protects the Higgs mass from receiving large corrections?

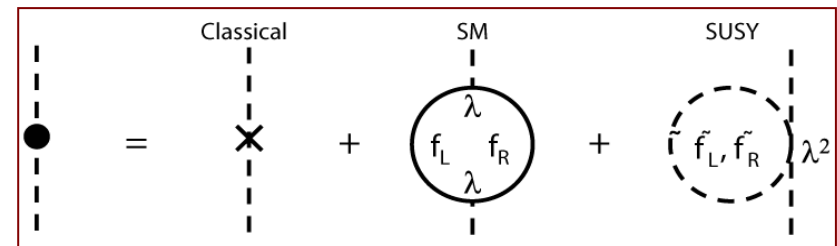

# Higgs and the SM (cont.)

- SUSY postulates a new symmetry between fermions and bosons
  - Loops of particles and their SUSY partners have the ability to cancel the quadratic divergences in the Higgs field self-couplings, solving the naturalness problem
  - SUSY foresees unification of couplings at large energy scales  $\sim 10^{15}$  GeV
  - Provides DM candidates (LSP)
- It suggests many options, but the LHC may not be able to find it
- # of experimental scenarios is large

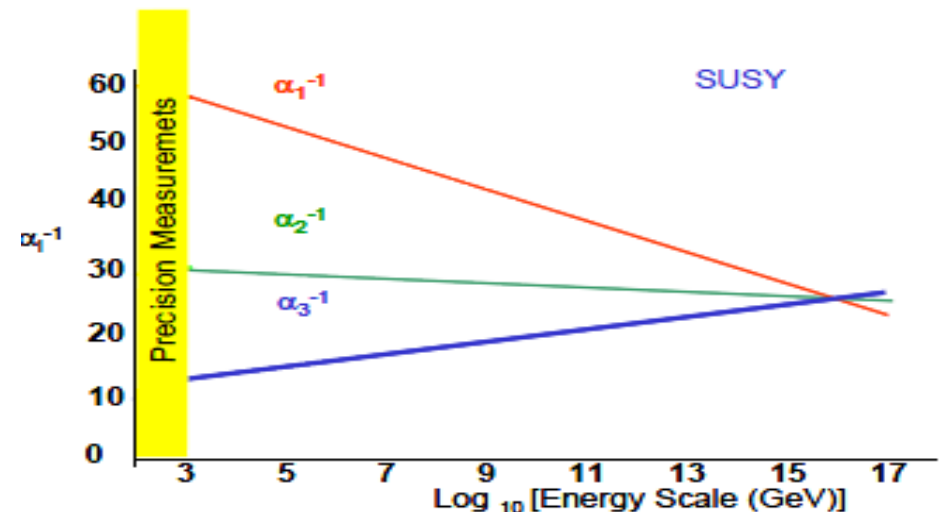

# Higgs and BSM

ATLAS-CONF-2015-044, CMS-HIG-15-002

- Is there BSM physics **hidden** in the “Higgs sector”?

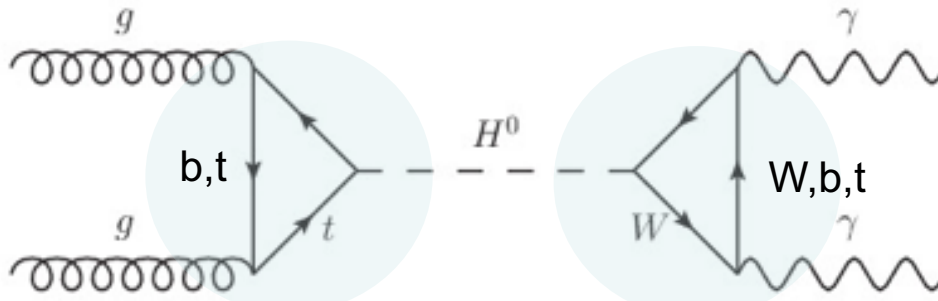

$$(\sigma \cdot \text{BR})(gg \rightarrow H \rightarrow \gamma\gamma) = \sigma_{\text{SM}}(gg \rightarrow H) \cdot \text{BR}_{\text{SM}}(H \rightarrow \gamma\gamma) \cdot \frac{\kappa_g^2 \cdot \kappa_\gamma^2}{\kappa_H^2}$$

Strategy: parametrize deviations wrt SM in production and decay  
 ⇒ loops are sensitive to BSM physics

## Experimental approach

- Measure H(125) properties
- Search for additional Higgs bosons
- Search for BSM in signatures with Higgs bosons
- Search for BSM Higgs decays

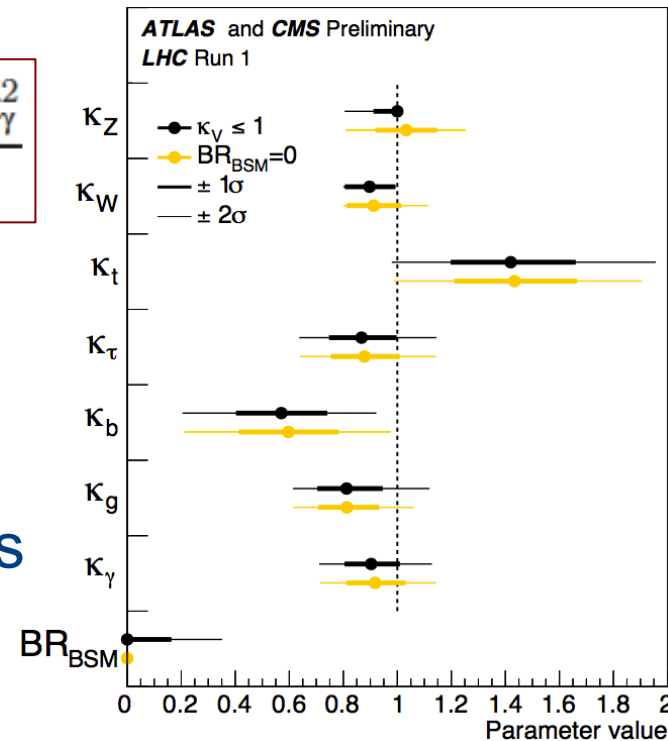

# Looking for new particles

JHEP08(2016)045

- Constrain  $BR_{BSM}$  in a scenario with free parameters
- $\Gamma_{tot} = \Gamma_{WW} + \Gamma_{ZZ} + \Gamma_{bb} + \dots + \Gamma_{BSM}$
- Likelihood scan vs  $BR_{BSM}$
- Assuming couplings bound by SM expectations ( $k_v < 1$ )
- $0 \leq BR_{BSM} \leq 0.34$  at 95%CL

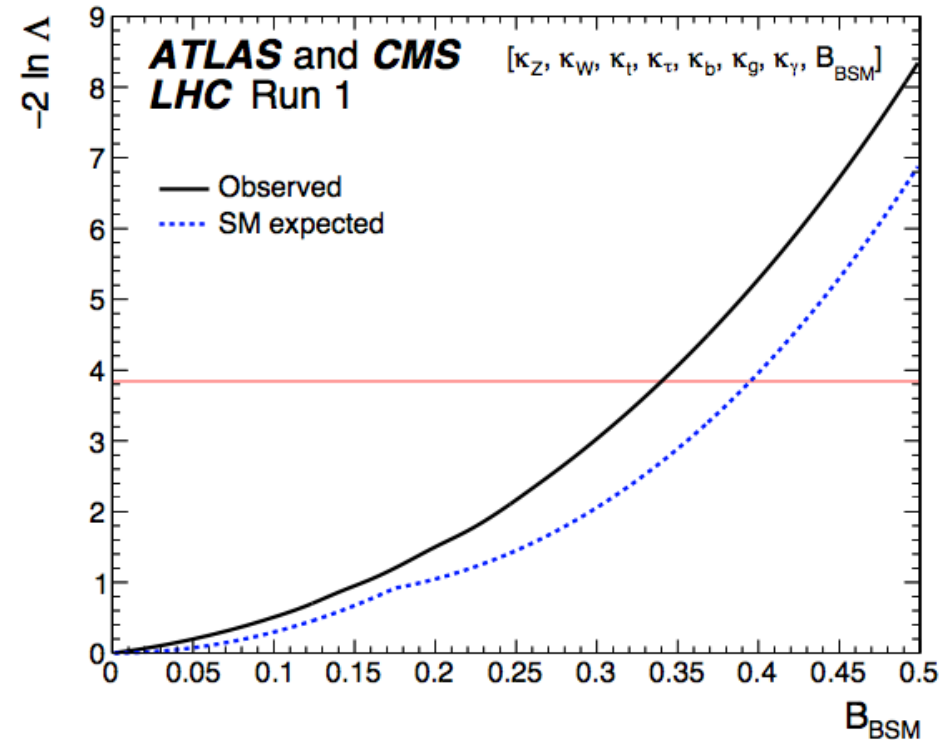

# Constraining Higgs width

PLB 736(2014)64

- couplings and width are sensitive probes to BSM
- indirectly constrained in coupling fits
- **off-peak to on-peak ratio proportional to  $\Gamma_H$**
- constrain Higgs boson width by using off-shell production/decay
- measure ratio of  $\sigma^{\text{off-peak}}$  to  $\sigma^{\text{on-peak}}$

$$\sigma_{gg \rightarrow H \rightarrow ZZ}^{\text{on-peak}} \propto \frac{g_{ggH}^2 g_{HZZ}^2}{\Gamma_H}, \quad \sigma_{gg \rightarrow H \rightarrow ZZ}^{\text{off-peak}} \propto g_{ggH}^2 g_{HZZ}^2$$

F. Caola, K. Melnikov PRD88(2013)054024  
 J. Campbell et al. arXiv:1311.3589

-  $g_{ggH}$  and  $g_{HZZ}$ : couplings to gluons and bosons

- measurement of  $\Gamma_H$

obs.(exp.) @95%CL:

$$\Gamma_H < 5.4(8.0) \Gamma_H^{\text{SM}}$$

$$\Gamma_H < 22(33) \text{MeV}$$

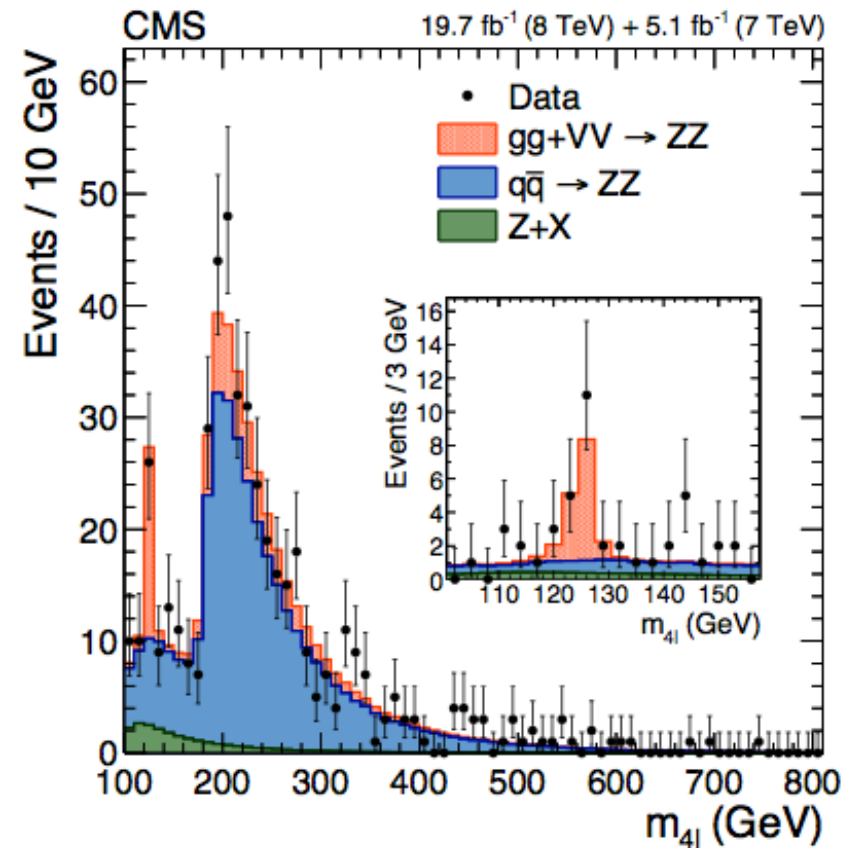



# Couplings: decays

ATLAS-CONF-2015-044, CMS-HIG-15-002, JHEP08(2016)045

## BSM physics in the loop

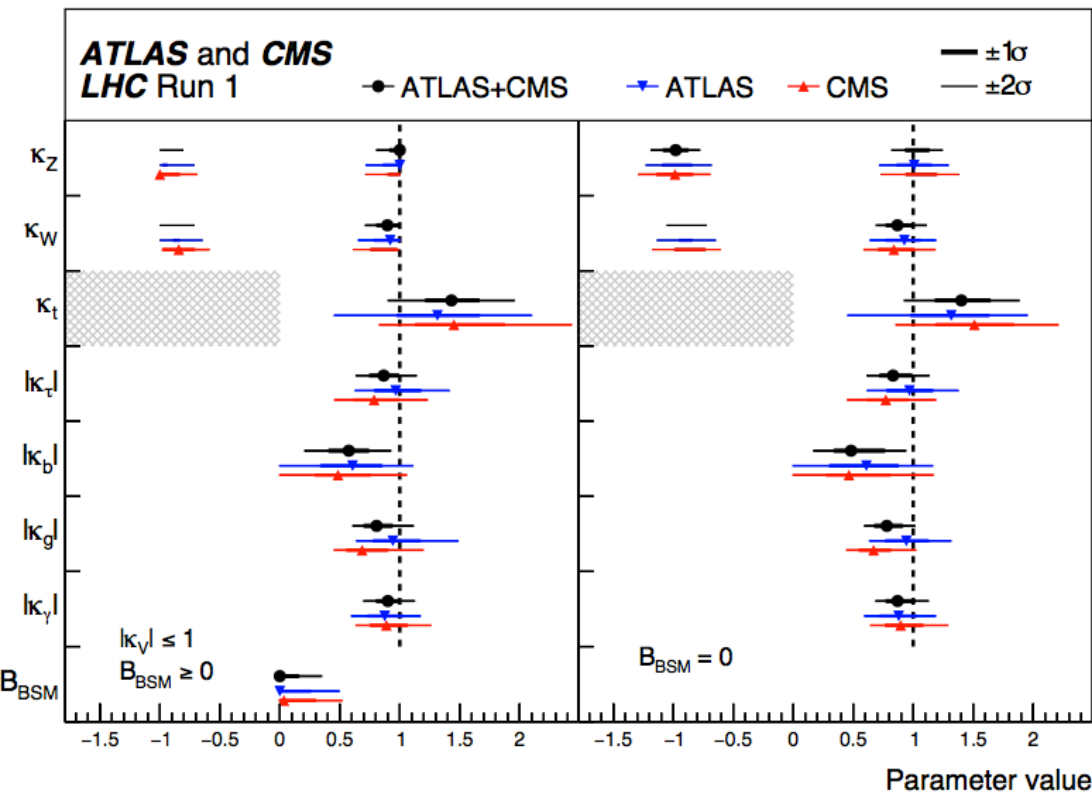

## Vector and fermion couplings

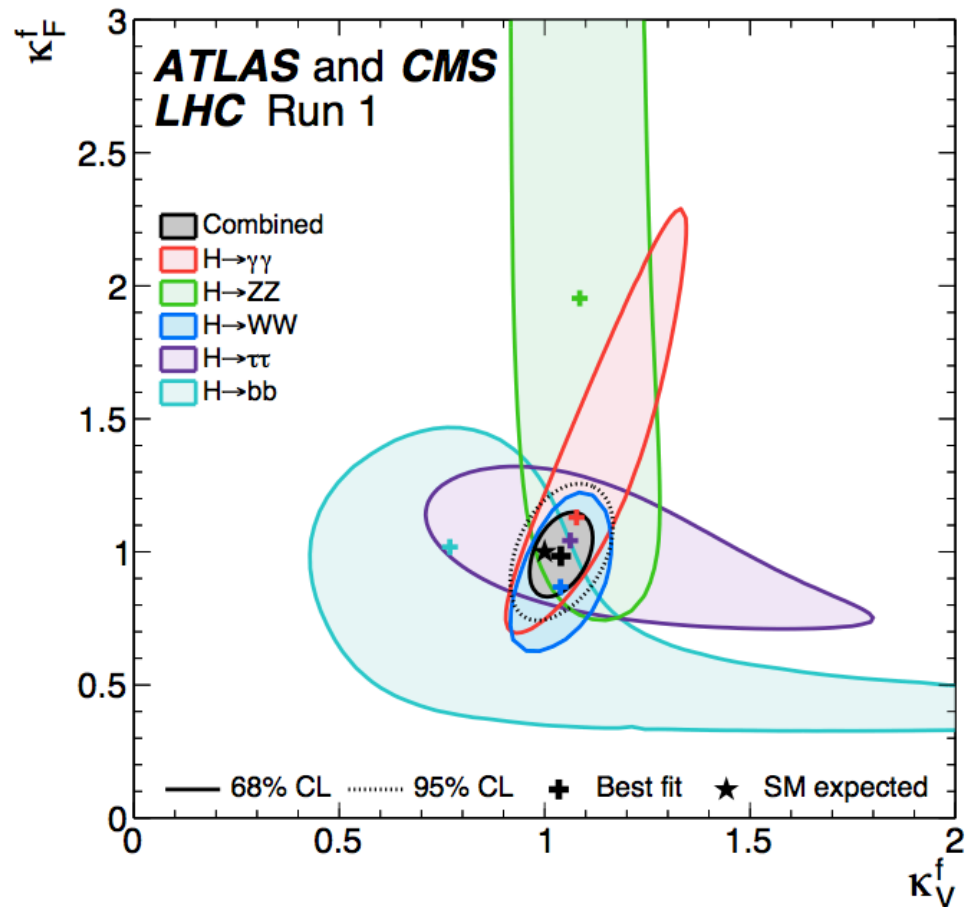

$BR_{\text{BSM}}$  can be measured

$BR_{\text{BSM}} < 0.34$  at 95% C.L. (assuming  $\kappa_V \leq 1$ )

$BR_{\text{BSM}}$  includes non standard decays, visible or invisible

⇒ Results in agreement with SM ( $\kappa_V = \kappa_F = 1$ ) within  $1\sigma$

# Consistency with SM

arXiv:1809.10733

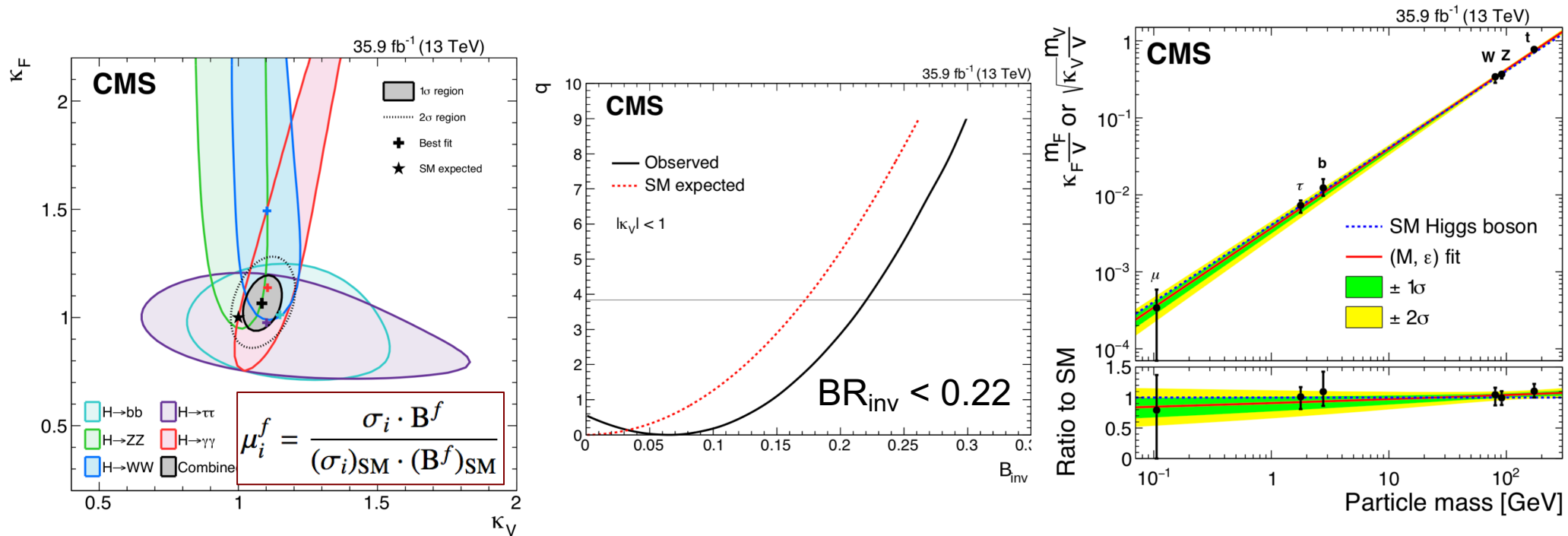

# Consistency with SM

CMS HIG-19-005

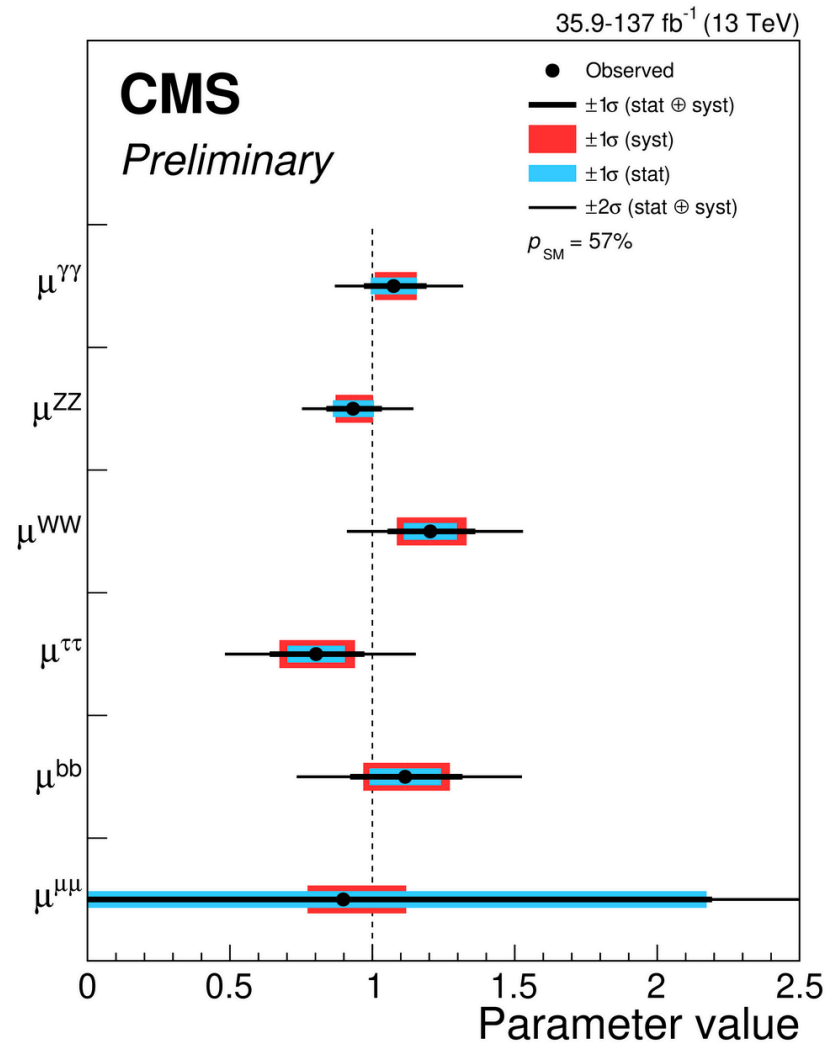
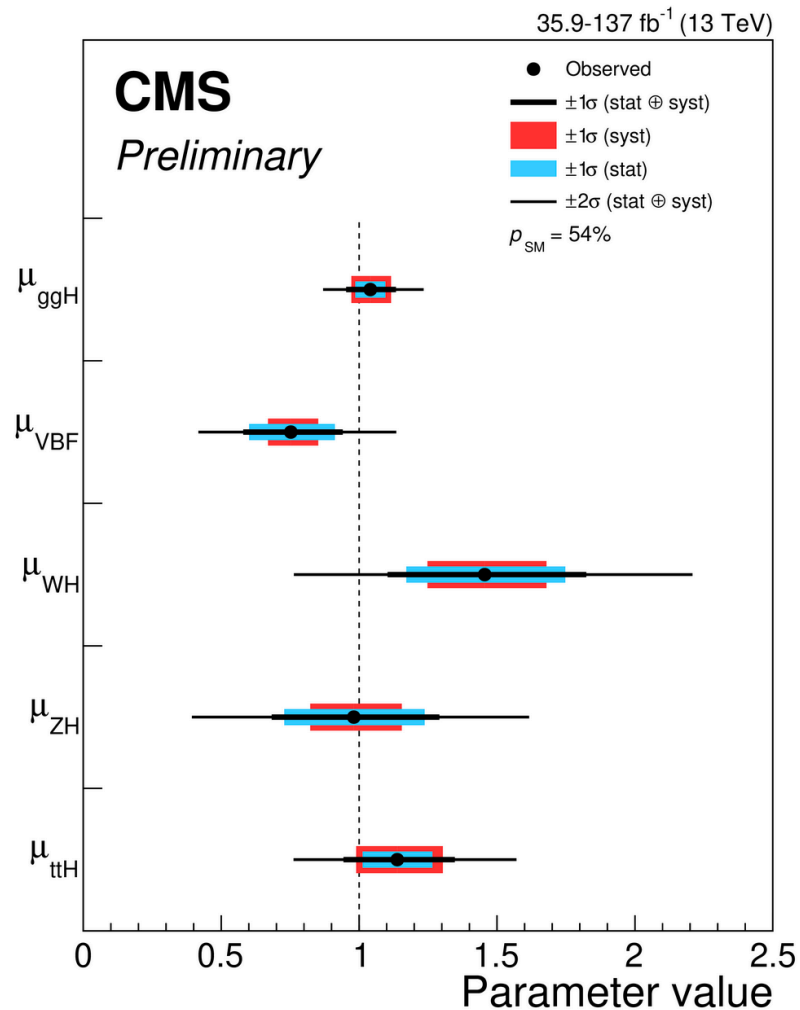

# High mass: $H \rightarrow WW/ZZ$

JHEP 10(2015)144, HIG-16-033, HIG-16-034, arXiv:1912.01594

- Search for a heavy Higgs boson
  - $H \rightarrow ZZ \rightarrow 4l, 2l2\nu, 2lqq$
  - $H \rightarrow WW \rightarrow 2l2\nu, 2lqq$
- optimized separately for VBF and gluon fusion production processes
- Combined upper limits at 95% CL on the product of  $\sigma \times \text{BR}$  exclude a heavy Higgs boson with SM-like couplings and decays up to 1870 GeV
- Search interpreted in BSM scenario (heavy Higgs, heavy EWK singlet state)
  - evolution of signal strength of the singlet state with modified couplings/width wrt SM.
  - assume new scalar does not decay to any new particle

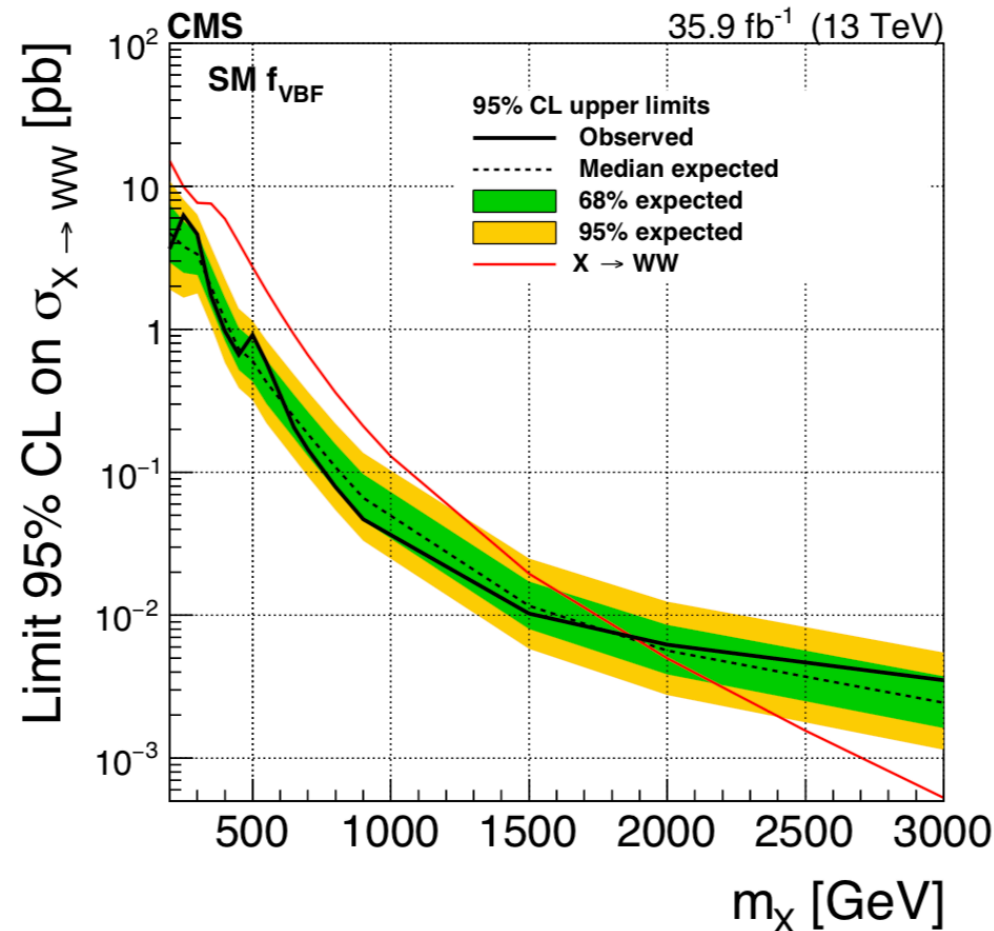

# Heavy Higgs: dibosons

arXiv:1804.01939, JHEP03(2018)174, arXiv:1804.01126

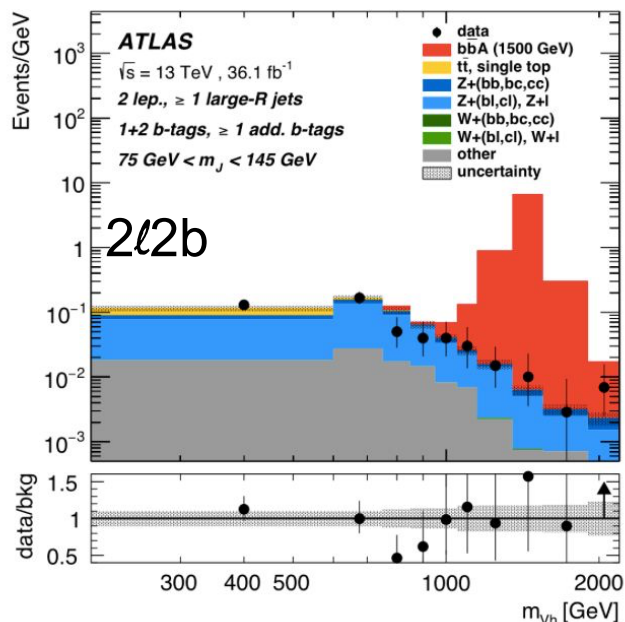
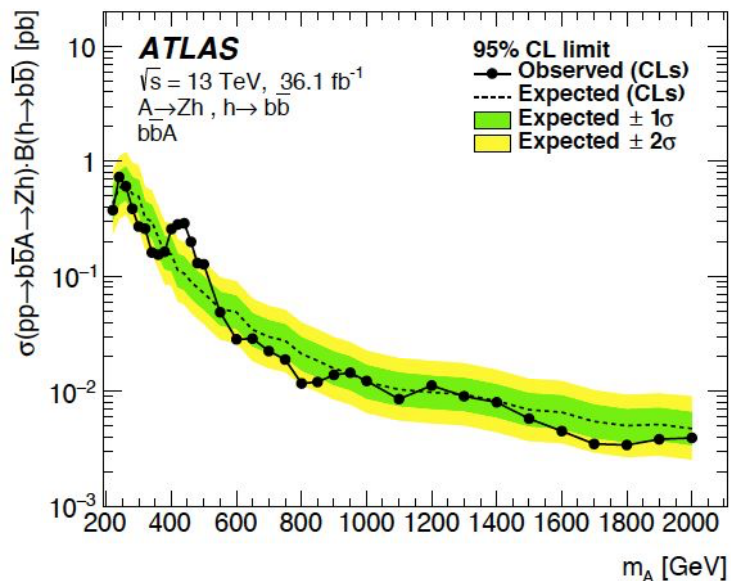
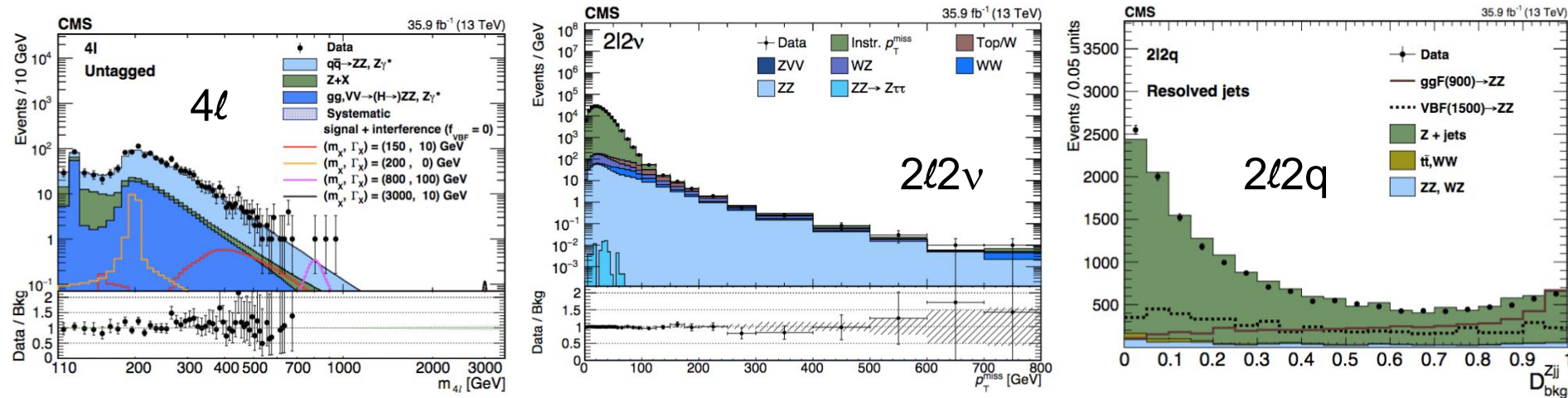

Hunting for a bump in the diboson mass spectrum

# Extending searches

- Minimal Supersymmetric SM (MSSM)
  - Neutral Higgs:  $\phi \rightarrow \tau\tau/bb/\mu\mu$
  - Charged Higgs
- Next-to-MSSM
  - Light pseudoscalar:  $h \rightarrow aa$
  - Non-SM decays:  $h \rightarrow 2a \rightarrow 4\tau/4\mu$
  - Heavy Higgs:  $H \rightarrow h_{125}h_{125}$  or  $A \rightarrow Zh_{125}$
- FCNC:  $t \rightarrow cH$

# Higgs sector in the MSSM

Higgs sector in SUSY contains two scalar doublets:

- 5 physical Higgs bosons
  - 3 neutral: CP-even  $\phi=h, H$  CP-odd  $A$
  - 2 charged  $H^\pm$
- SM-like Higgs boson:  $h$

Neutral Higgs  $\phi$  decay modes:

- $\text{BR}(\phi \rightarrow b\bar{b}) \sim 90\%$
- $\text{BR}(\phi \rightarrow \tau\tau) \sim 10\%$
- $\text{BR}(\phi \rightarrow \mu\mu) \sim 0.1\%$

Two main production modes:

- $gg \rightarrow H$
- $b\bar{b}H$

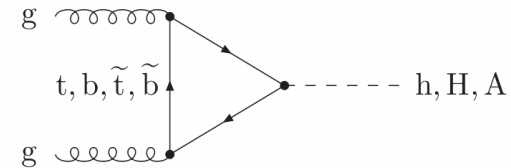
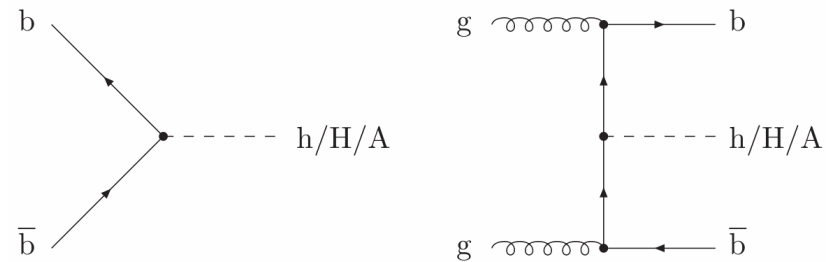

# Neutral MSSM Higgs

JHEP 10(2014)212, arXiv:1803.06553

- Enhanced couplings of MSSM Higgs to down-type fermions (large  $\tan\beta$ )  
 $\Rightarrow$  increased BR to  $\tau$  leptons and b-quarks

$$m_T^{\text{tot}} = \sqrt{m_T^2(p_T^{\tau_1}, p_T^{\tau_2}) + m_T^2(p_T^{\tau_1}, p_T^{\text{miss}}) + m_T^2(p_T^{\tau_2}, p_T^{\text{miss}})},$$

- Search for neutral MSSM Higgs boson
- 5 final states used:  $\mu\tau_h$ ,  $e\tau_h$ ,  $\tau_h\tau_h$ ,  $e\mu$ ,  $\mu\mu$ 
  - Reconstruct tau-pair invariant mass
  - Split in b-tag/no b-tag categories to enhance sensitivity
- Main backgrounds:  $Z \rightarrow \tau\tau$ , QCD/W+jets, DY, ttbar, dibosons

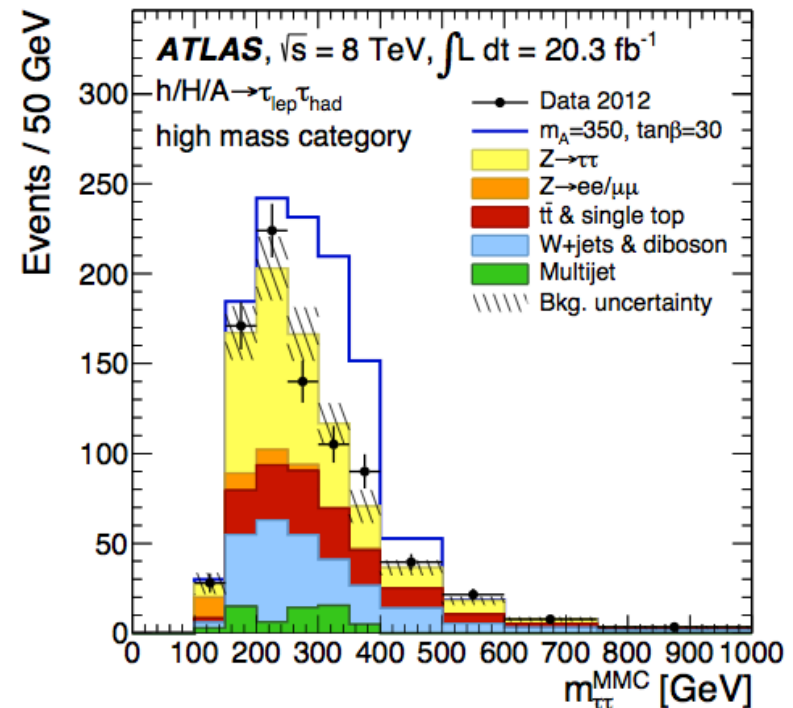
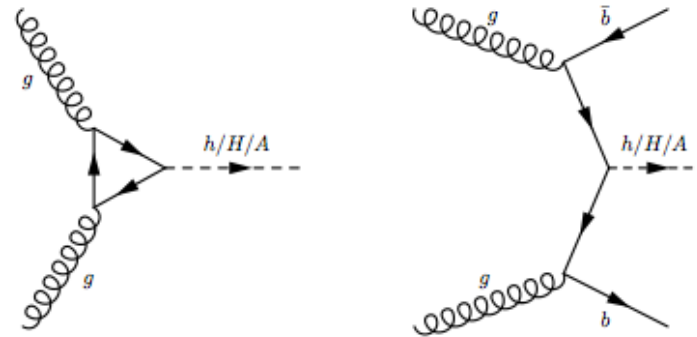



# Neutral MSSM Higgs: $\phi \rightarrow \tau\tau$

JHEP 09(2018)007

- Direct search: inclusive and b-tagged
- $\tau$  in both leptonic and hadronic decays

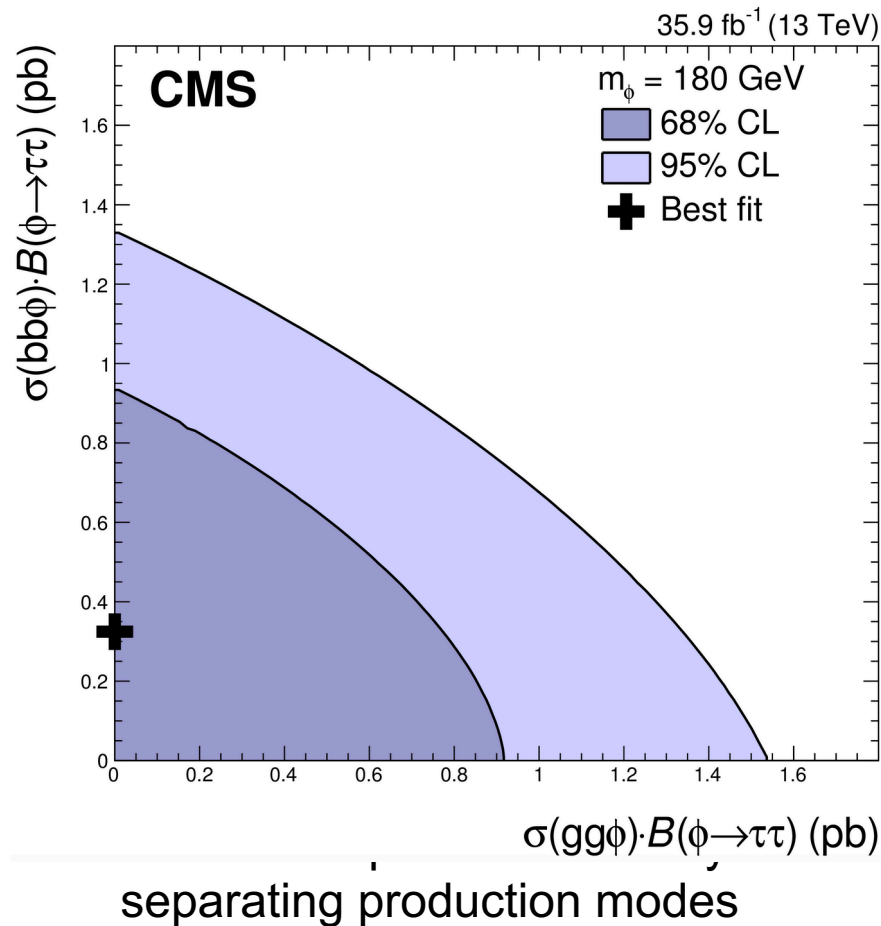

$\tan\beta$  vs  $m_A$  window becoming smaller

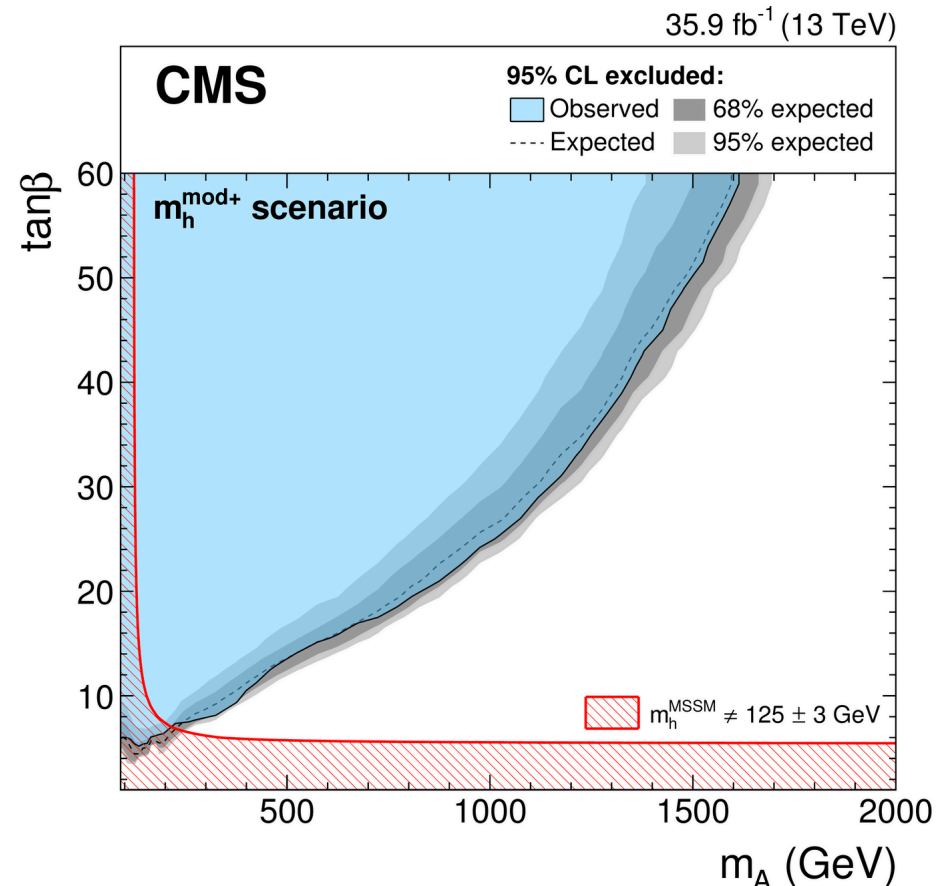

No significant excess over bkg expectations

# Neutral MSSM Higgs: $\phi \rightarrow \mu\mu$

arXiv:1508.01437, JHEP07(2019)117

- Search for a  $\mu\mu$  mass resonance
- Good mass resolution
  - full and clean reconstructed final state
- Split in b-tagged and non b-tagged categories to be sensitive to  $gg \rightarrow \phi$  and  $bb\phi$  production modes
- Main backgrounds:  $Z(b\bar{b})$ ,  $t\bar{t}$ ,  $WW$

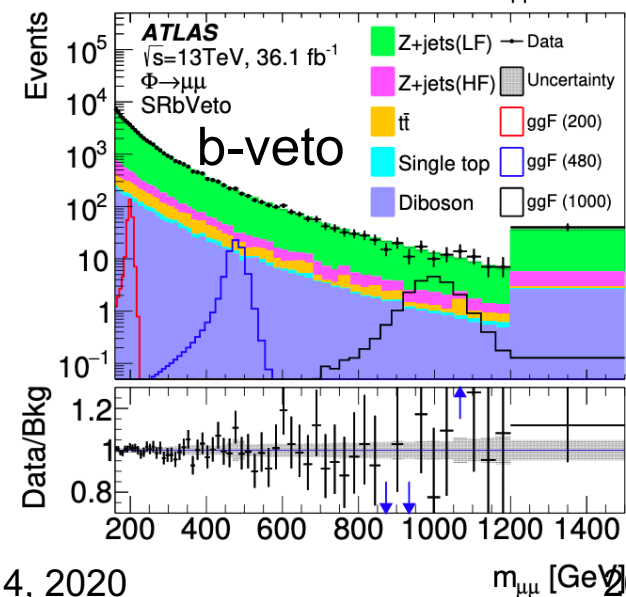
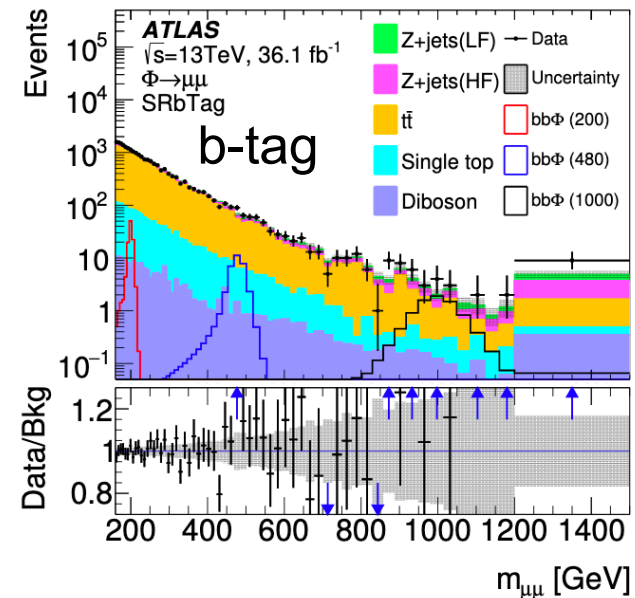
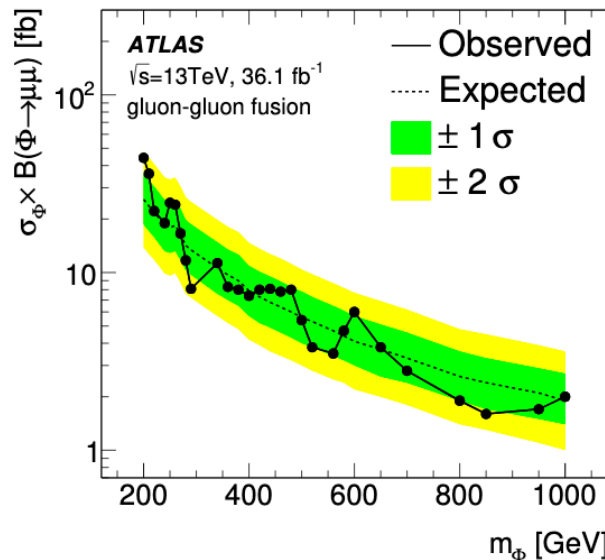
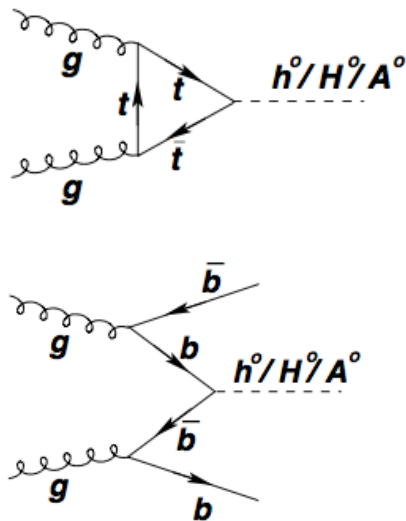

# Charged Higgs

- If found, a clear indication of BSM
- Study non-SM Higgs in **two mass regimes**:
- $m_H < m_{\text{top}}$ 
  - Mostly produced in top quark decays
  - Large  $\tan\beta$ :  $H^\pm \rightarrow \tau^+\nu$
  - Small  $\tan\beta$  ( $<1$ ):  $H^+ \rightarrow c\bar{s}$
- $m_H > m_{\text{top}}$ 
  - Produced in gluon-gluon fusion
  - Main decays:  $H^+ \rightarrow tb$ ,  $H^+ \rightarrow \tau^+\nu$
- Main backgrounds:  $t\bar{t}$ ,  $W$ +jets

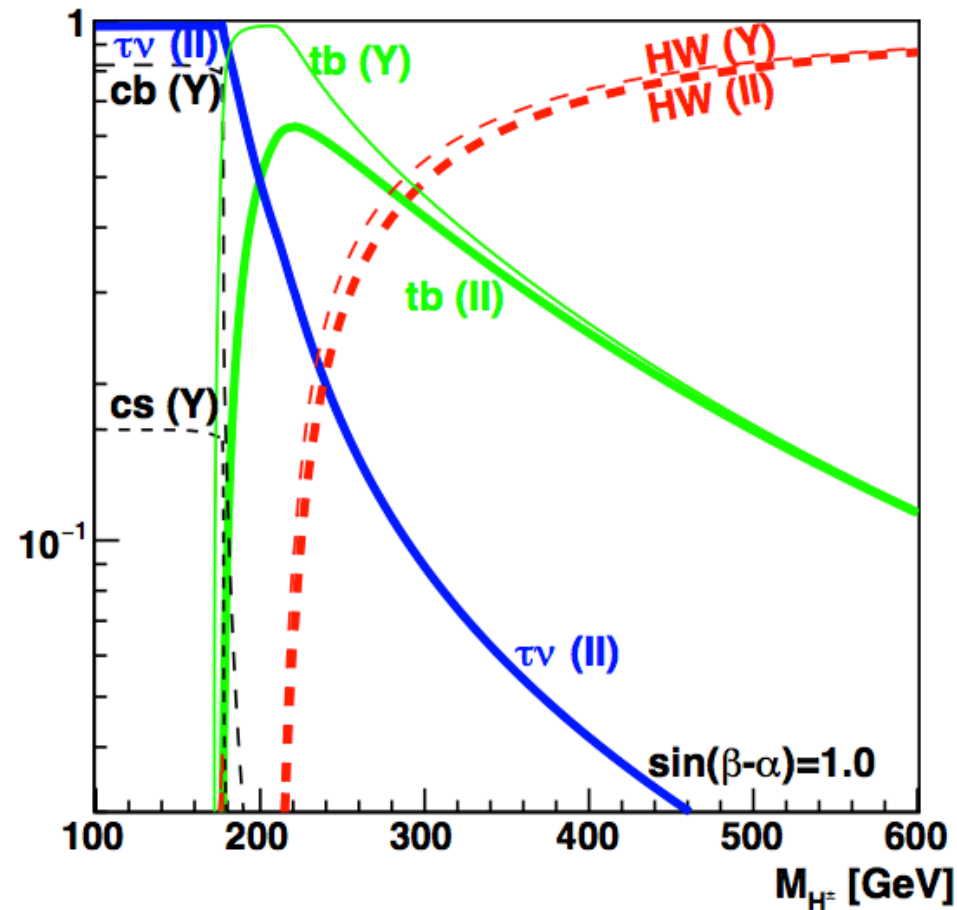

# Charged Higgs (cont.)

- Different strategies for low- and high-mass searches
- tau+lepton, lep+jets, and  $e\mu$  final states
- b-tagged jet categorization
- limited by statistics at high-mass

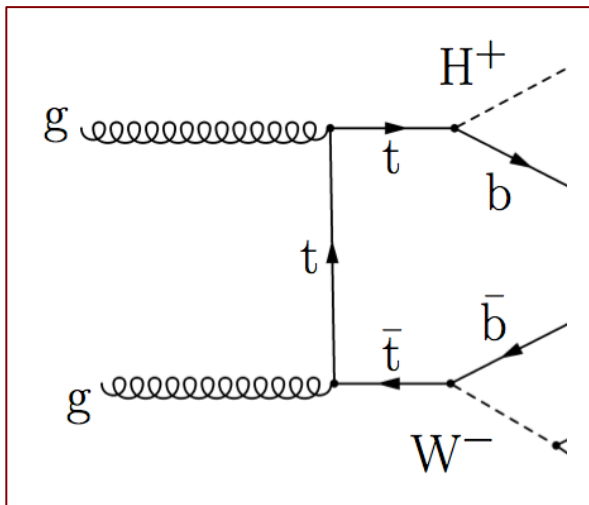
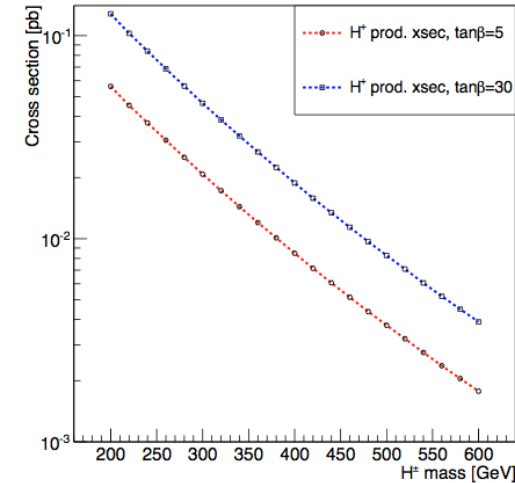

$$m_H < m_{top}$$

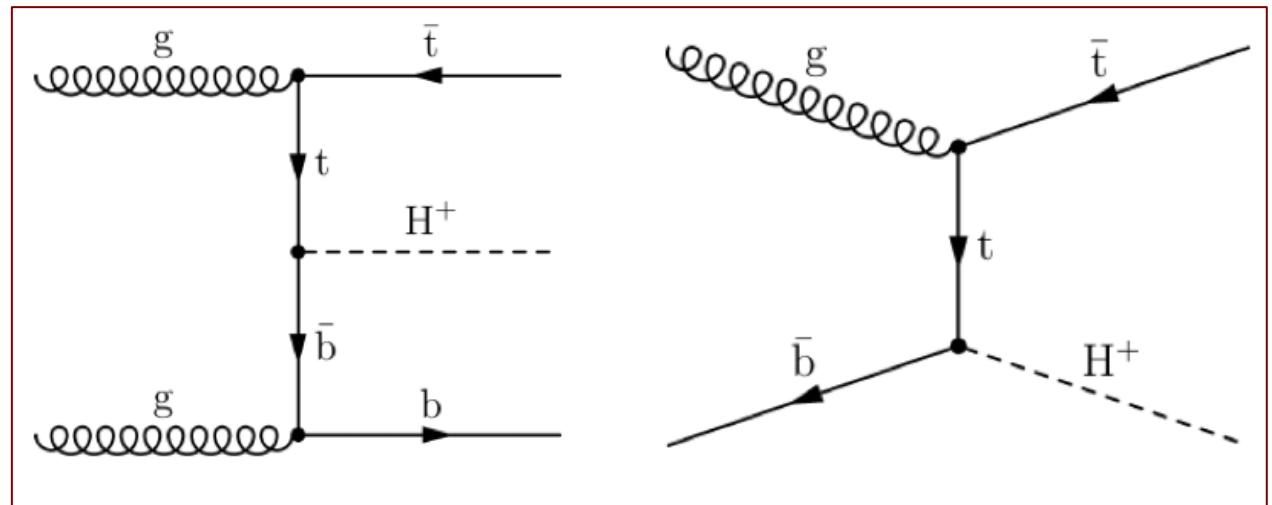

$$m_H > m_{top}$$

# Charged Higgs and top quark decays

JHEP 07(2012)143, arXiv:1508.07774, HIG-16-031

- Look for charged Higgs in four final states:

- Tau+lepton (electron or muon)
- Dilepton (tau decays leptonically)
- lepton+jets
- Fully hadronic: tau+jets

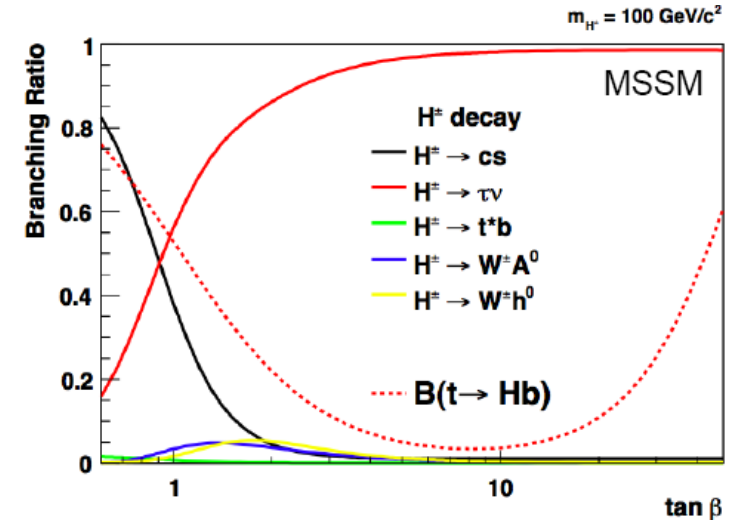

## $\tau_h$ +jets

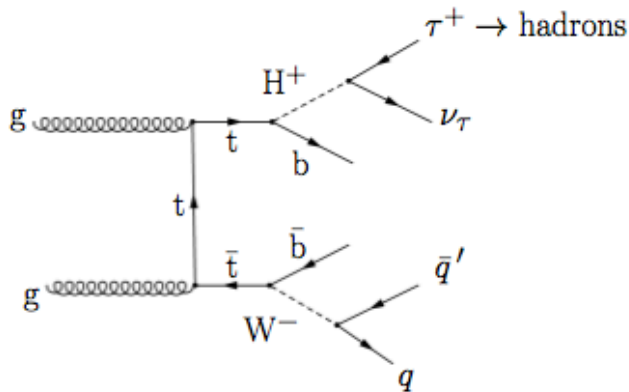

## $\tau_h$ +lepton (e/μ)

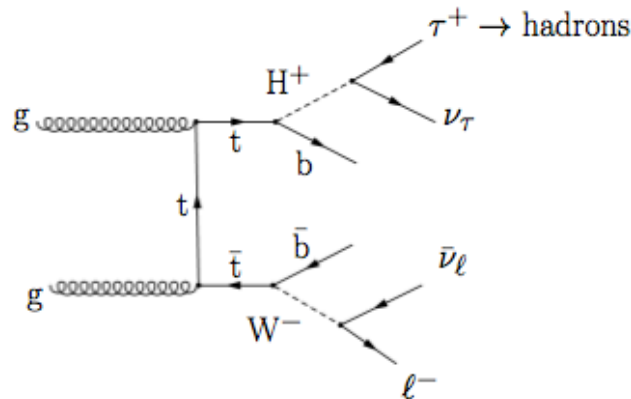

## di-lepton (eμ)

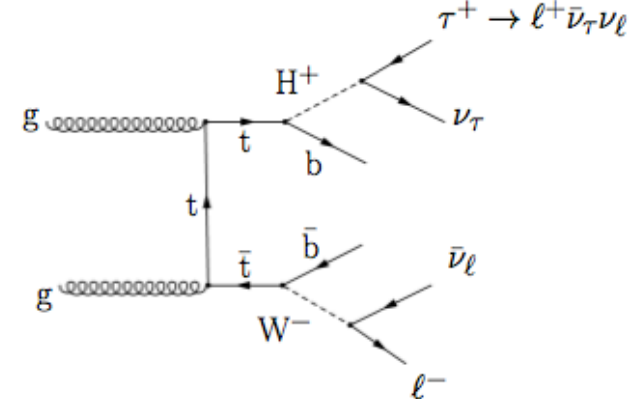

# Looking at tau decays

CMS-HIG-12-052

## Low $H^+$ mass:

- Use R variable in the limit extraction: binned maximum-likelihood fit
- Tau fake component is data-driven, includes uncertainties

SM

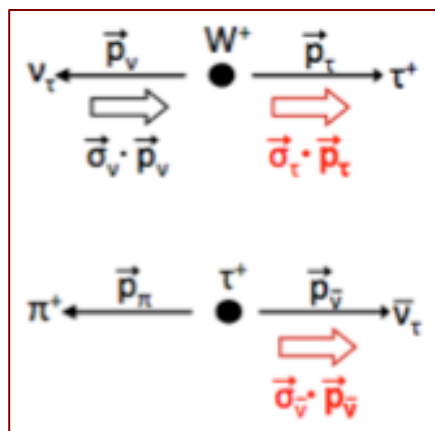

VS

BSM

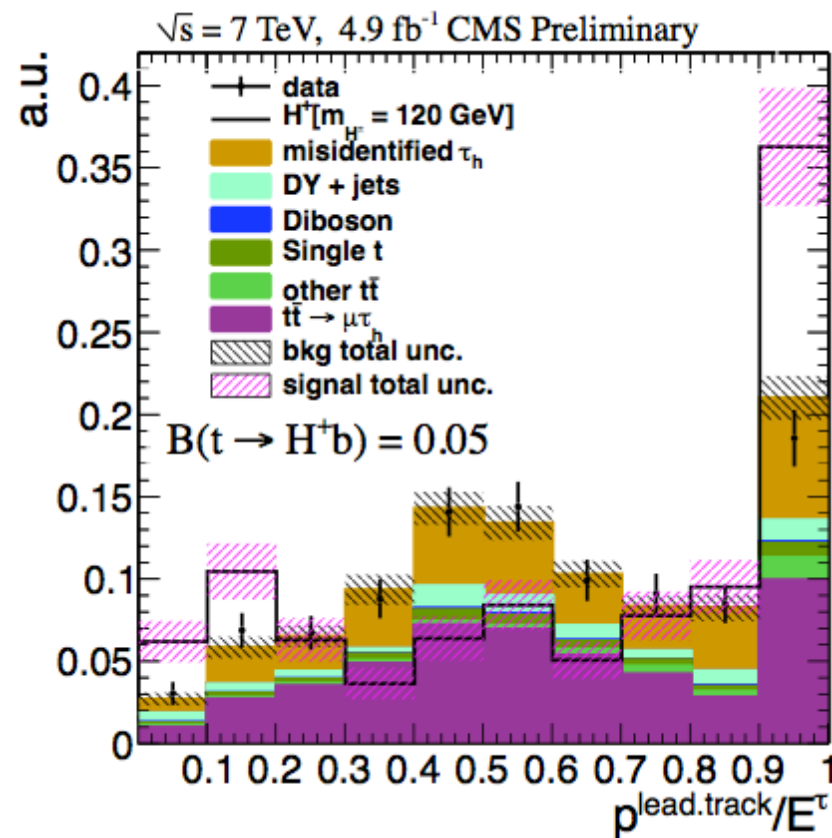
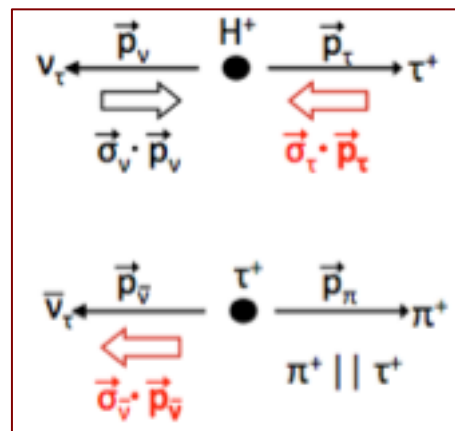

# Number of b-tagged jets

High-mass  $H^+$ : look at b-tag multiplicity

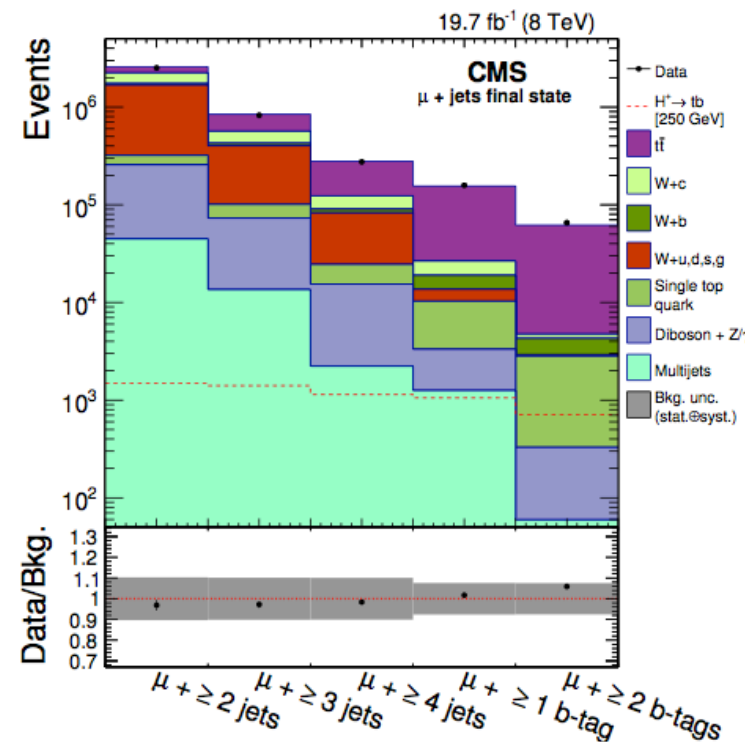
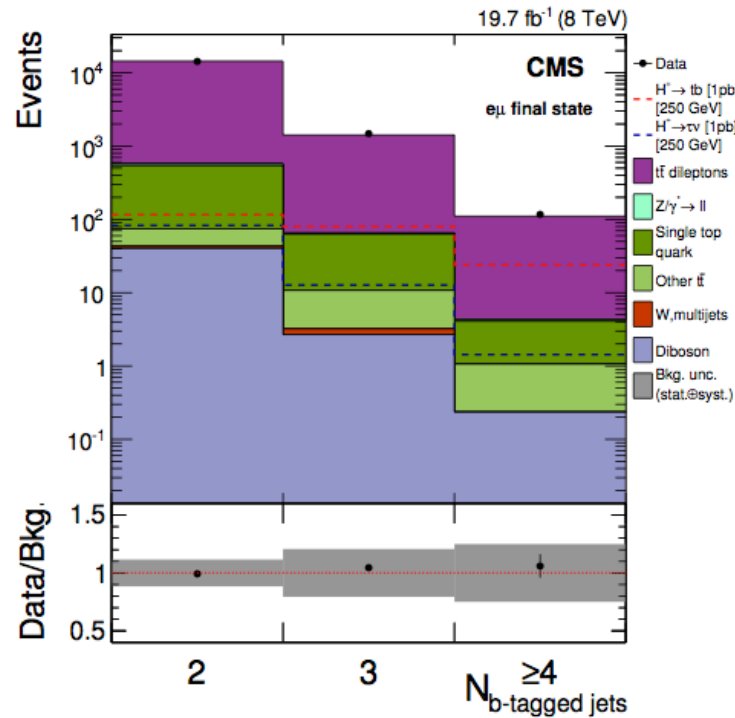
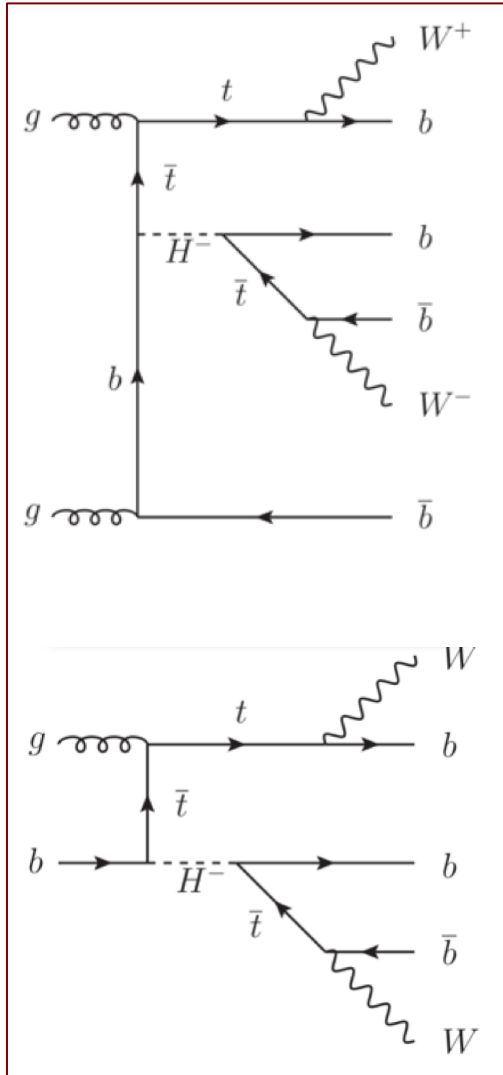

# Charged Higgs: $H^+ \rightarrow \tau\nu$

arXiv:1903.04560

## MSSM, high $\tan\beta$

- Final states:  $\tau$ +jets,  $\tau$ + $ll$ ,  $0\tau$ + $ll$
- 36 categories: incl. #jets, polarization  $R=p_T(t_k)/p_T(\tau)$
- Cross section limits: 80-3000 GeV

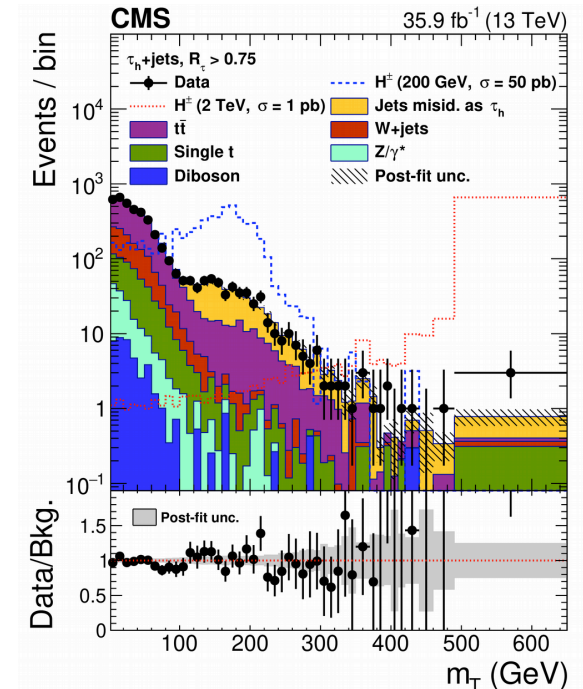
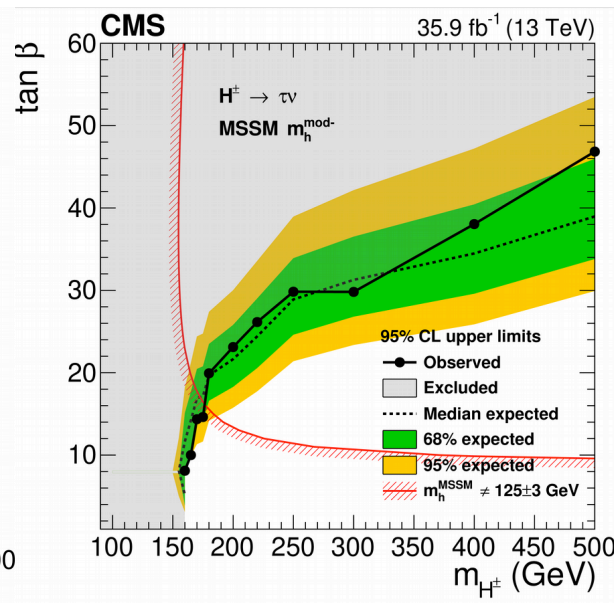
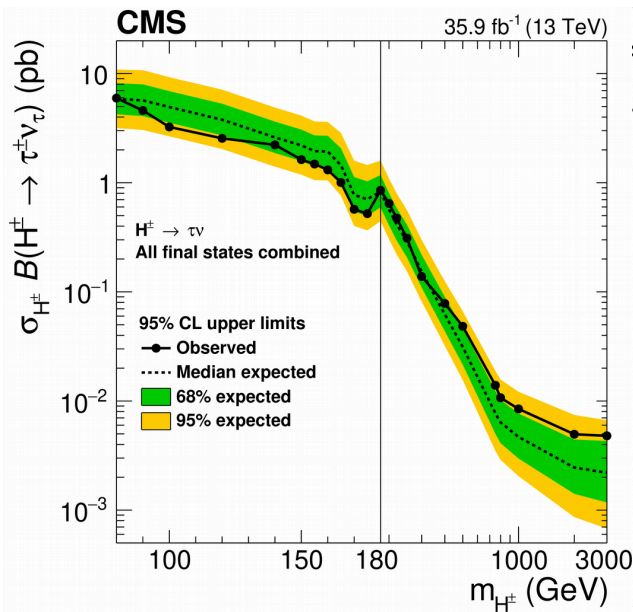
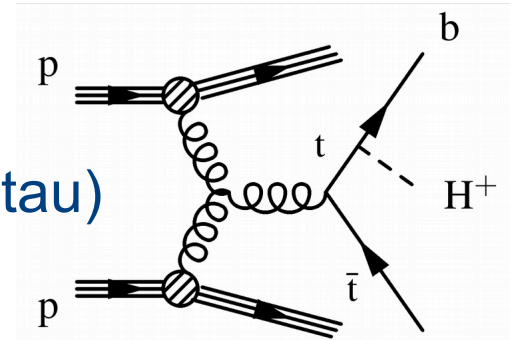



# Charged Higgs: $H^+ \rightarrow tb$

arXiv:1908.09206

## MSSM, low $\tan\beta$

- Final states:  $1\ell$  and  $2\ell$
- Categories (incl. #jets, #bjets)
- Discriminant vs  $t\bar{t}b$  (BDT and DNN)
- Mass range: 200-3000 GeV

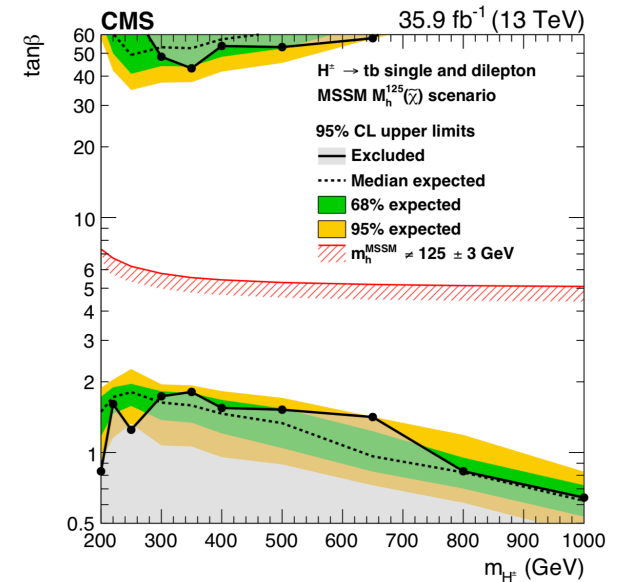
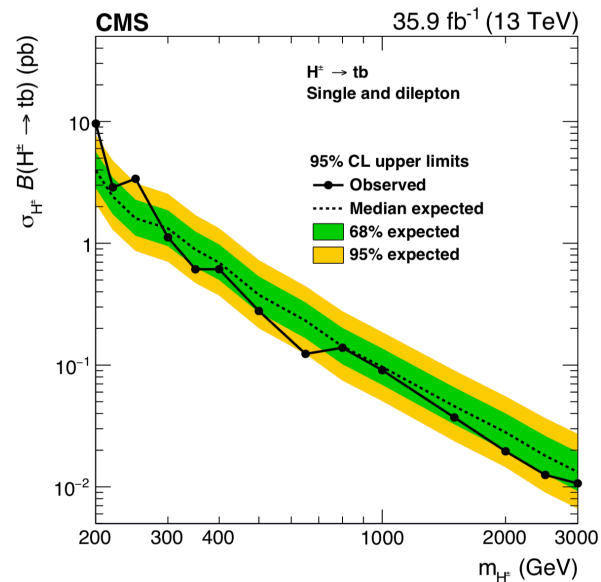
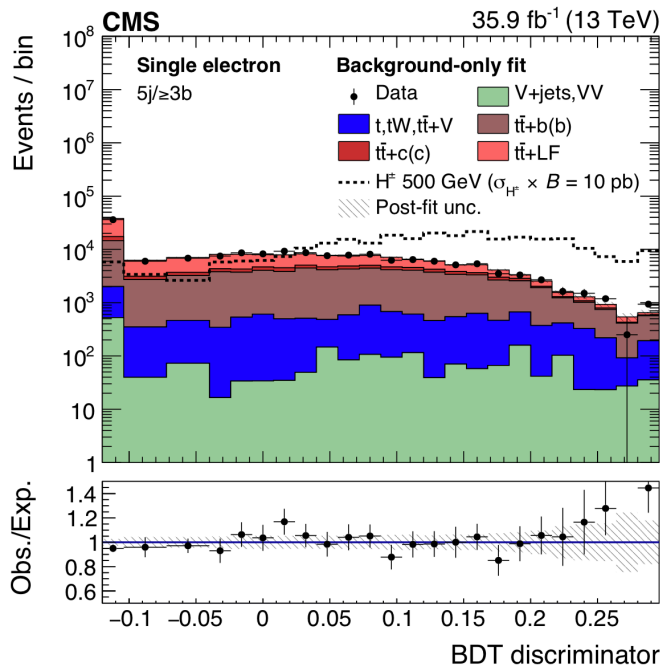
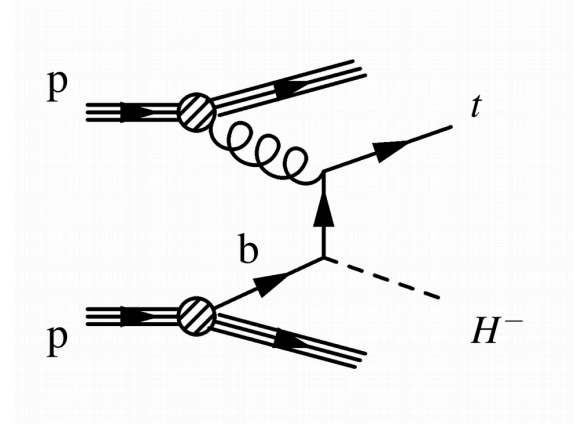

# Doubly charged Higgs

HIG-16-036, arXiv:1710.09748

## • Model

- SM extended with scalar triplet ( $\Phi^{++}$ ,  $\Phi^+$ ,  $\Phi^0$ )
- Triplet responsible for neutrino masses
- Search for doubly- and singly-charged
- DY pair production is most common
- SS lepton pair of any flavor combination

## • Search with $\geq 3$ leptons of any flavor

- Search for excess of events in one or more flavor combinations of SS lepton pairs

## • Dilepton invariant mass as discriminant

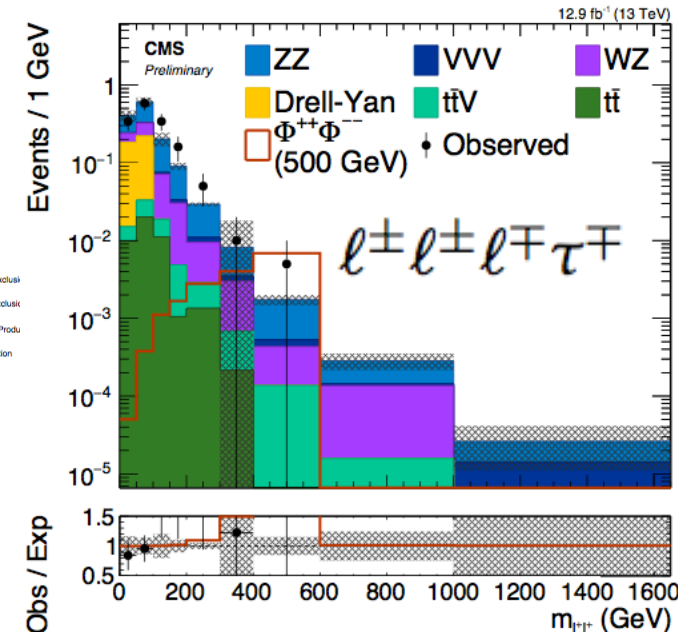
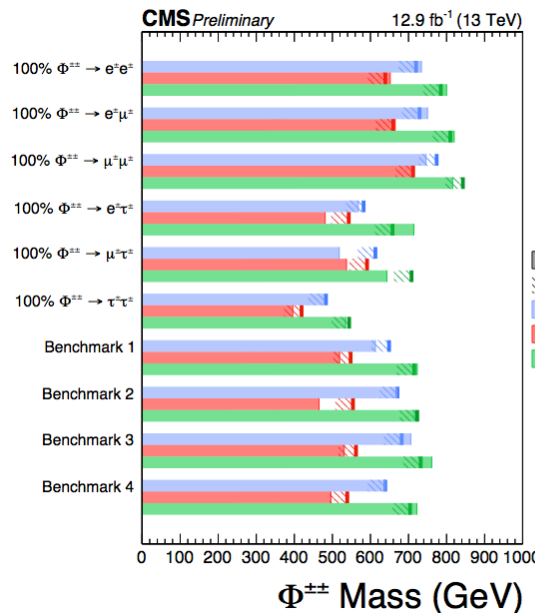
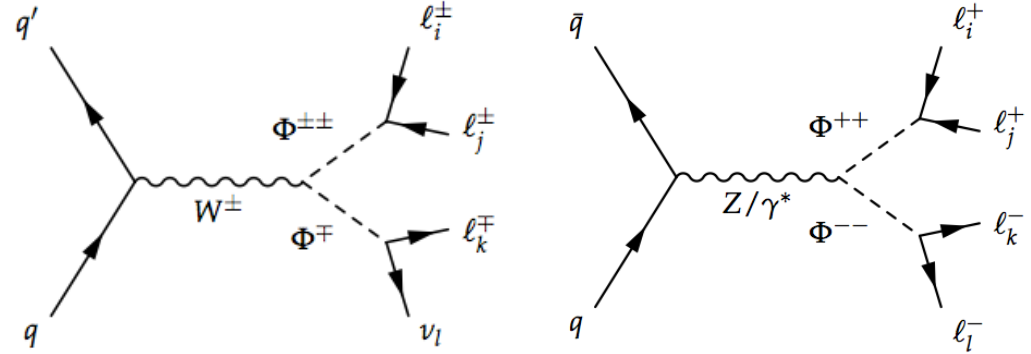

# non-SM Higgs decay: $h \rightarrow aa \rightarrow 4X$

- Standard search for light (pseudo)- scalar Higgs with  $m_a < m_h/2$ 
  - generic prediction of BSM theories (extended Higgs sector, NMSSM, etc)
  - Final states go to fermions ( $b, \tau, \mu, \dots$ )
  - BR depends on boson mass, model parameters

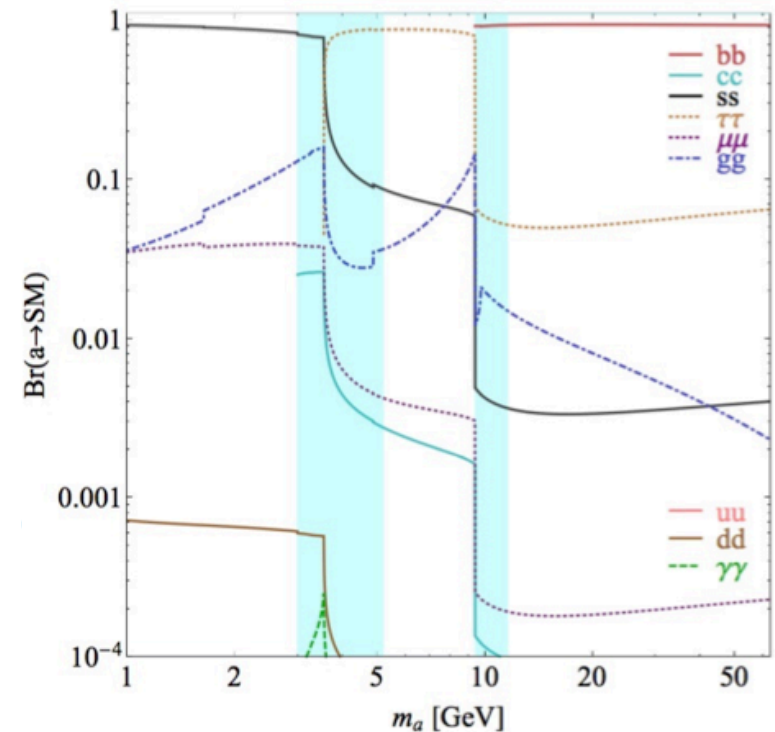
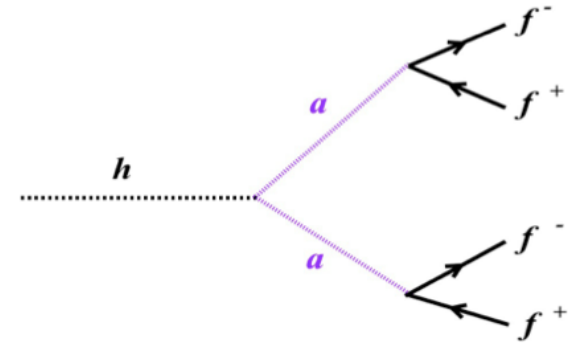

# non-SM Higgs decay: $h \rightarrow aa \rightarrow 4\mu$

PLB796(2019)131

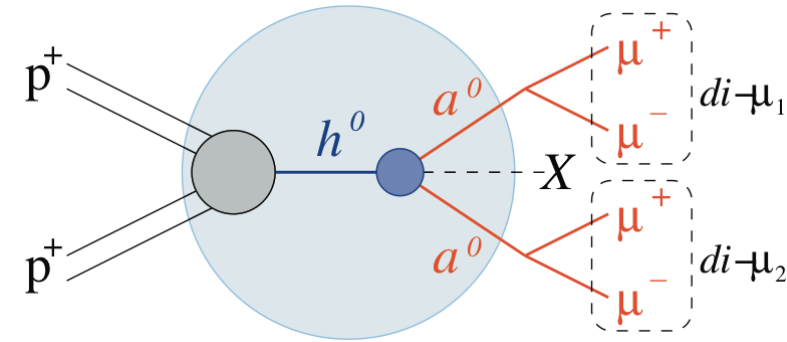

- Explore non-SM decays of a Higgs boson ( $h$ )
  - Higgs boson ( $h$ ) can be SM or not
  - include production of two new light boson ( $a^0$ )
- Search for generic Higgs decays:  $h \rightarrow 2a + X \rightarrow 4\mu + X$ 
  - Require two dimuon pairs with consistent masses
  - Signal region: **9 event** ( $\sim 8 \pm 2$  bkg)
  - Limits on production rates, benchmark models

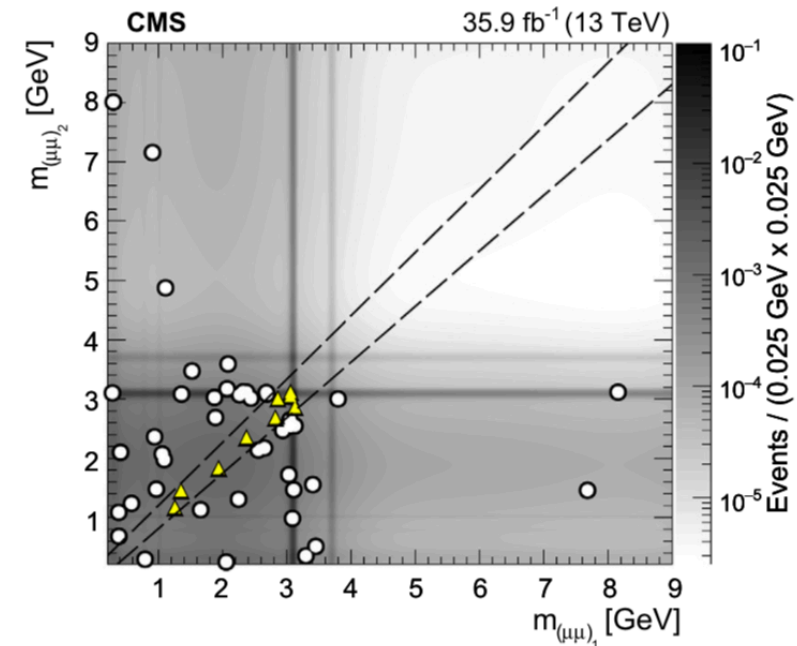

# NMSSM and Dark SUSY Limits

PLB 726(2013)564, arXiv:1506.00424

## Results interpreted in NMSSM and dark SUSY

- Dark SUSY:  $h$  decay to pair of neutralinos ( $n_1$ ): LSP

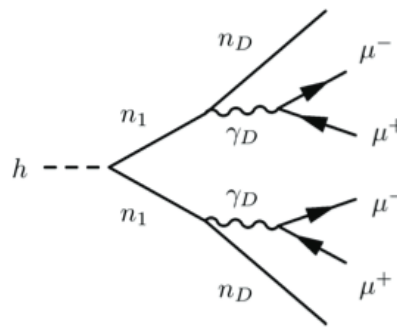
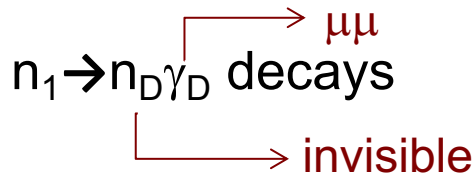

- NMSSM: Extend MSSM by adding a complex singlet field (1 CP-even+1 CP-odd boson)
- NMSSM:  $h_{1,2} \rightarrow 2a_1$ ;  $a_1 \rightarrow 2\mu$
- Compare to SM Higgs cross section

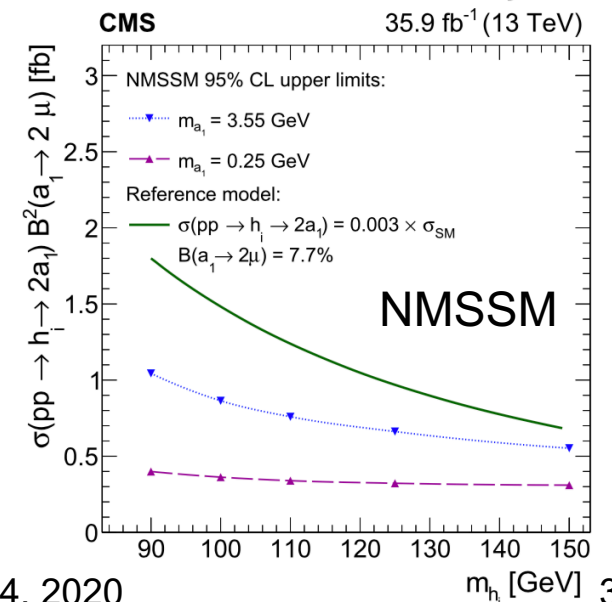
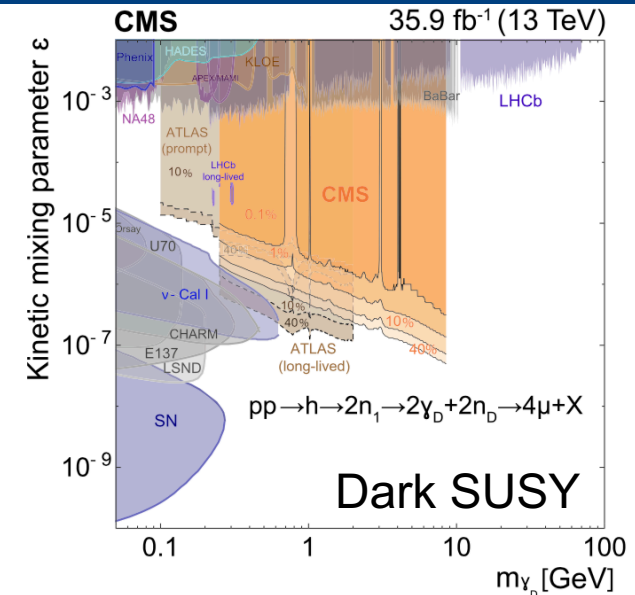

# non-SM Higgs decay: $H_{125} \rightarrow 2h(a) \rightarrow 4\tau$

JHEP01(2016)079

- Search for **very light Higgs** in NMSSM
  - $h_{1,2}$  (CP-even),  $a_{1,2}$  (CP-odd) to a pair of  $\tau$  leptons
  - $H(125) \rightarrow h_1 h_2 (a_1 a_2) \rightarrow 4\tau$
- Reconstruct  $\mu$ -track invar. mass ( $m_1, m_2$ )
  - SS dimuon sample (removes DY)
  - bin in 2-dim distribution, fit signal and bkg
  - QCD bkg from control region
- No excess over SM backgrounds

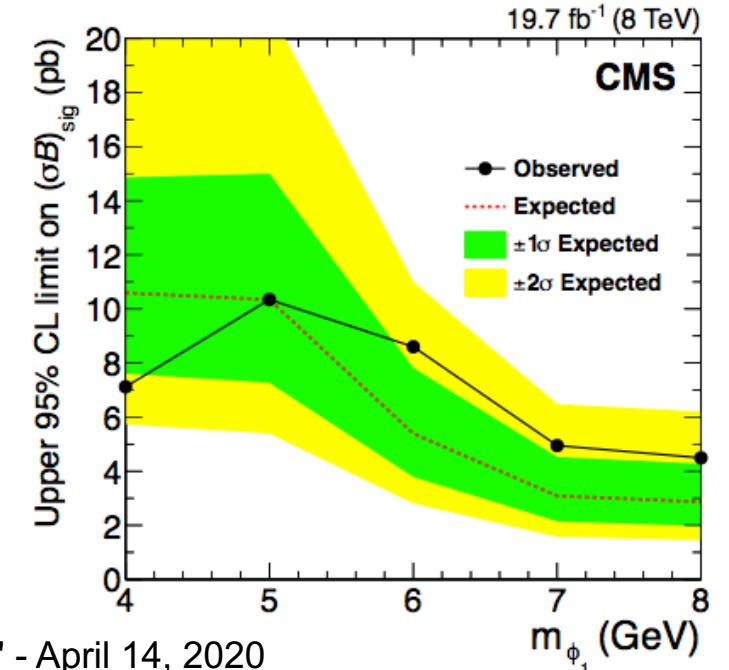
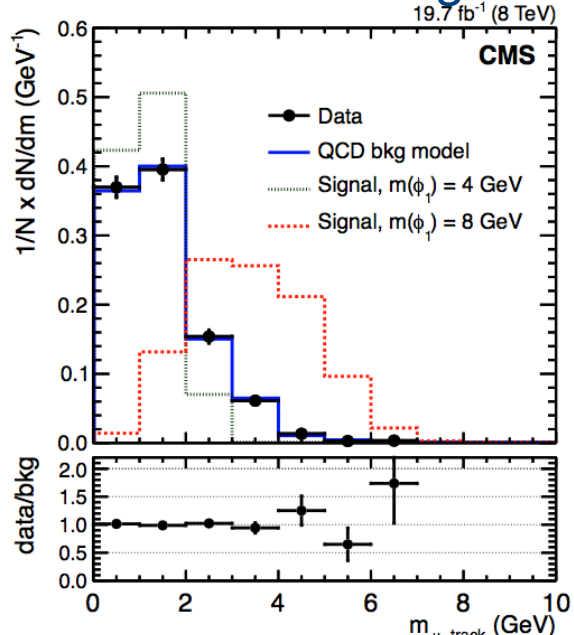
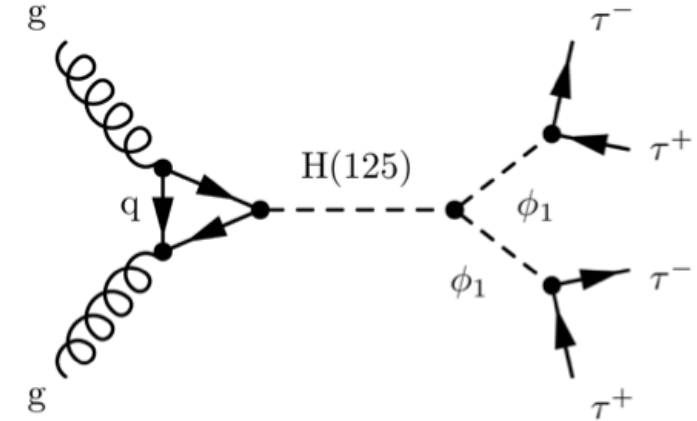

# Summary for Higgs exotic decays

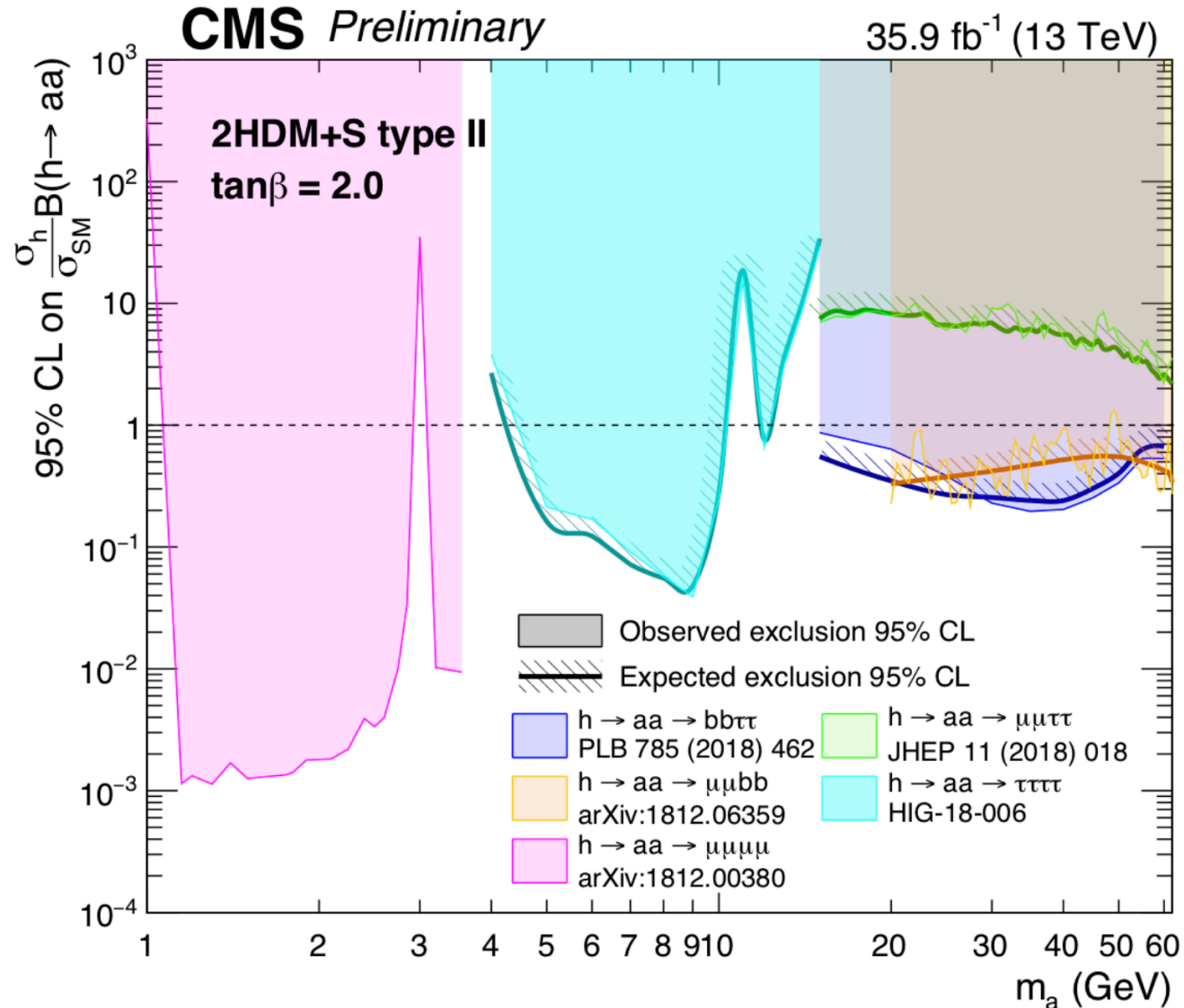

# Low mass Higgs: $a(\rightarrow\tau\tau)bb$

arXiv:1511.03610, JHEP05(2019)210

- Low mass Higgs in the NMSSM
- Low mass pseudo-scalar ( $a_1 \rightarrow \tau\tau$ ) in association with  $b\bar{b}$ :  $a_1 b\bar{b} \rightarrow \tau\tau b\bar{b}$
- Similar strategy to  $H \rightarrow \tau\tau$
- Search for  $a_1$  masses below Z mass
- No evidence for signal
- Set limits:  $\sigma \times B \sim 9-39$  pb

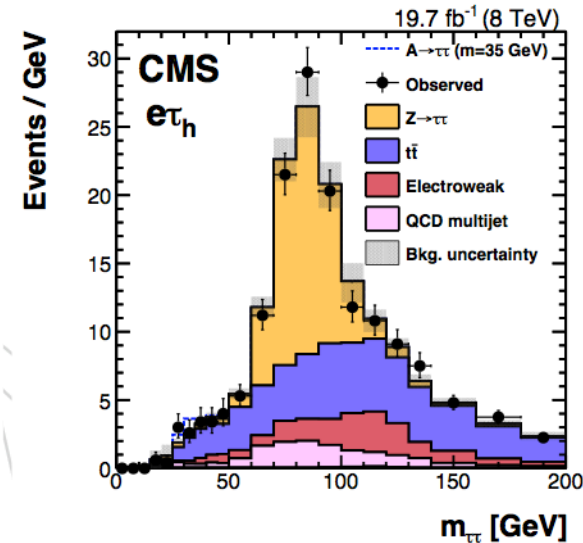
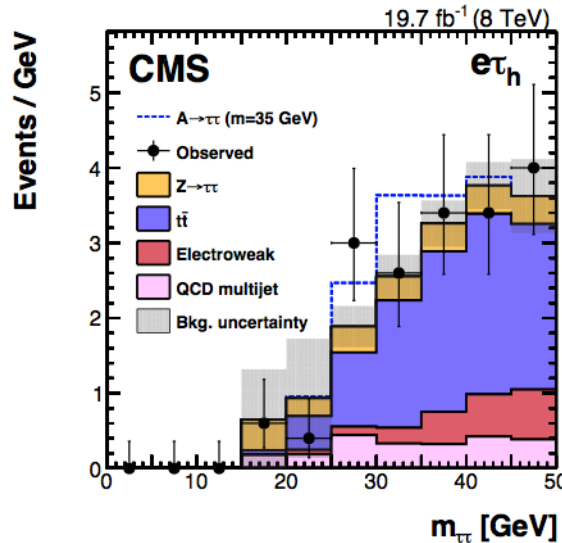
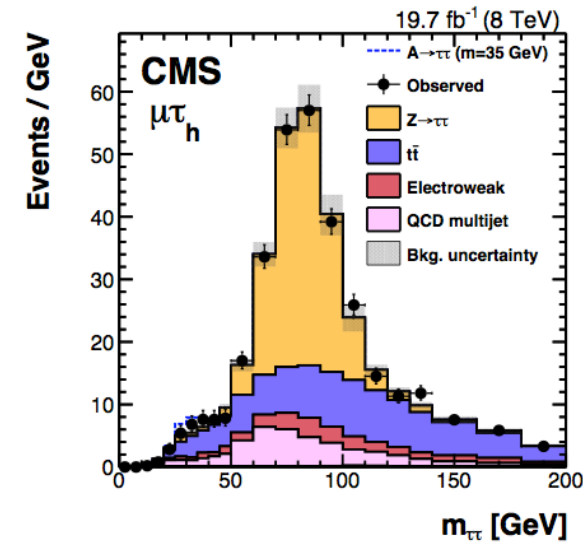
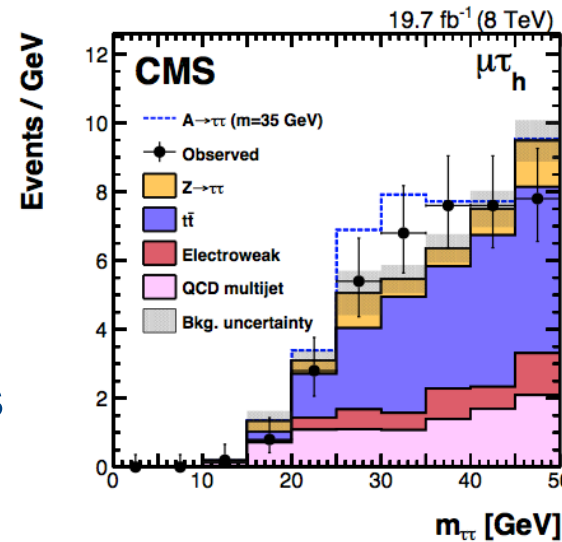
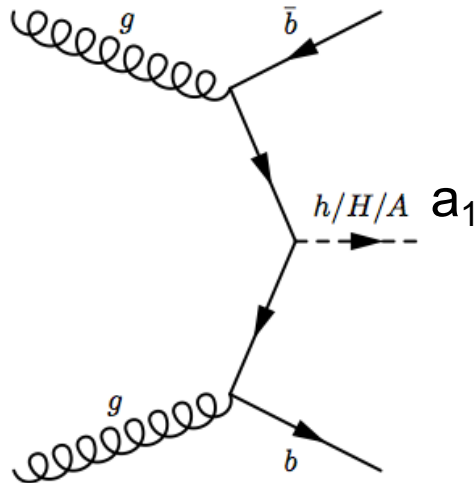



# Low mass Higgs: $a(\rightarrow\tau\tau)bb$

arXiv:1511.03610, JHEP05(2019)210

- Low mass Higgs in the NMSSM
- Low mass pseudo-scalar ( $a_1 \rightarrow \tau\tau$ ) in association with  $b\bar{b}$ :  $a_1 b\bar{b} \rightarrow \tau\tau b\bar{b}$
- Similar strategy to  $H \rightarrow \tau\tau$
- Search for  $a_1$  masses below  $Z$  mass
- No evidence for signal
- Set limits:  $\sigma \times B \sim 20 - 0.3 \text{ pb}$

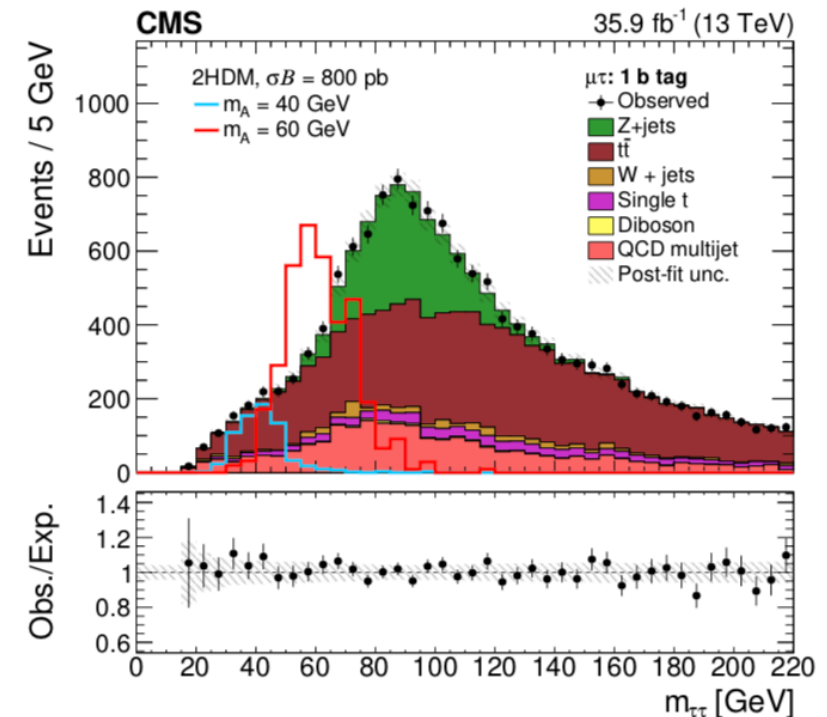
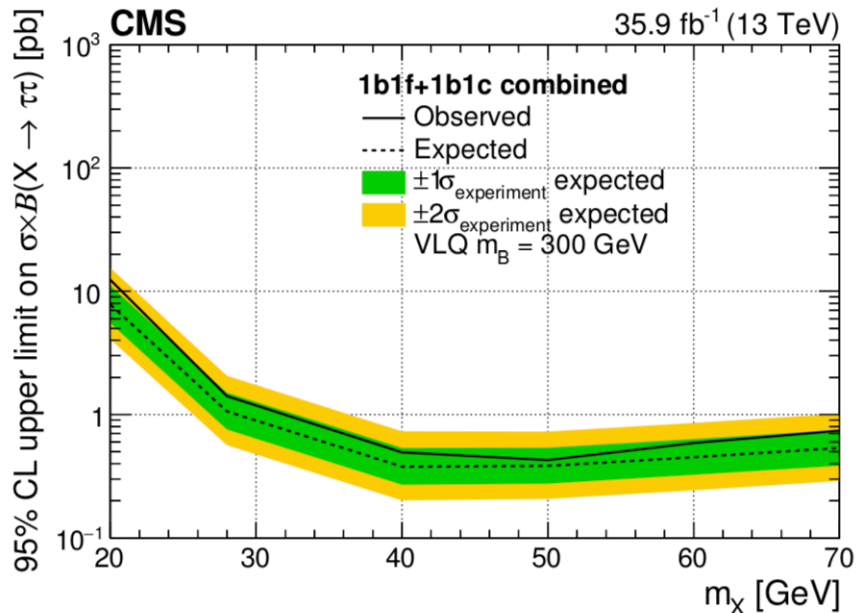
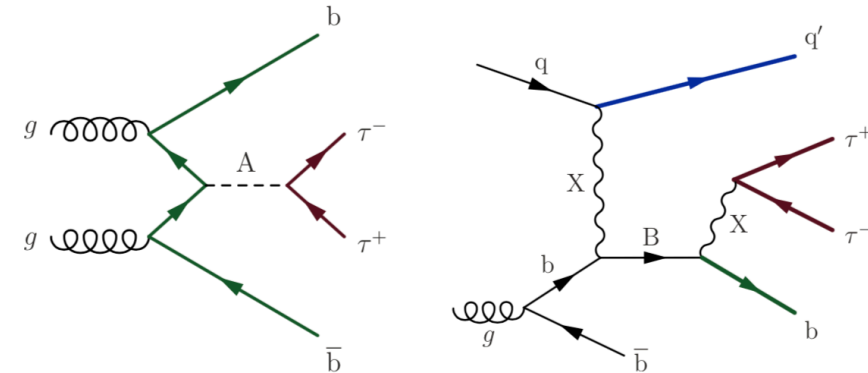

# Heavy Higgs: $H \rightarrow t\bar{t}$

arXiv:1908.01115

- MSSM, low  $\tan\beta$ ,  $m(H) > 2 \times m(\text{top})$
- Search for  $A/H \rightarrow t\bar{t}$
- Strong interference with SM  $t\bar{t}$
- $l$ +jets and  $ll$  final states
- Kinematic reconstruction
  - $m(t\bar{t})$  and  $\cos\theta^*$  (lepton angle in  $t\bar{t}$  frame)

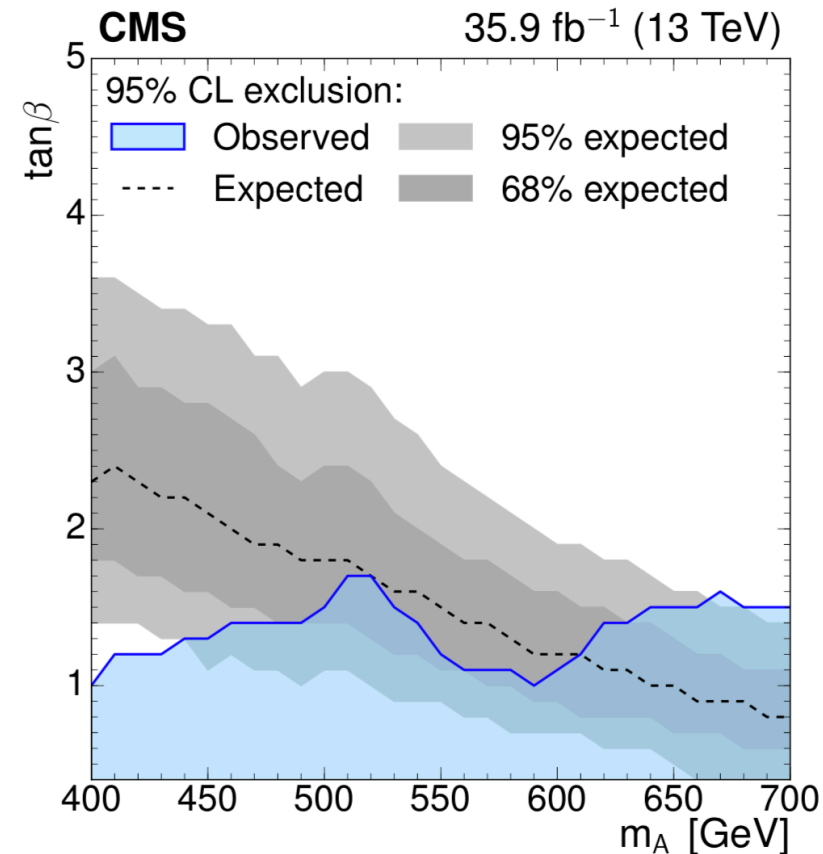
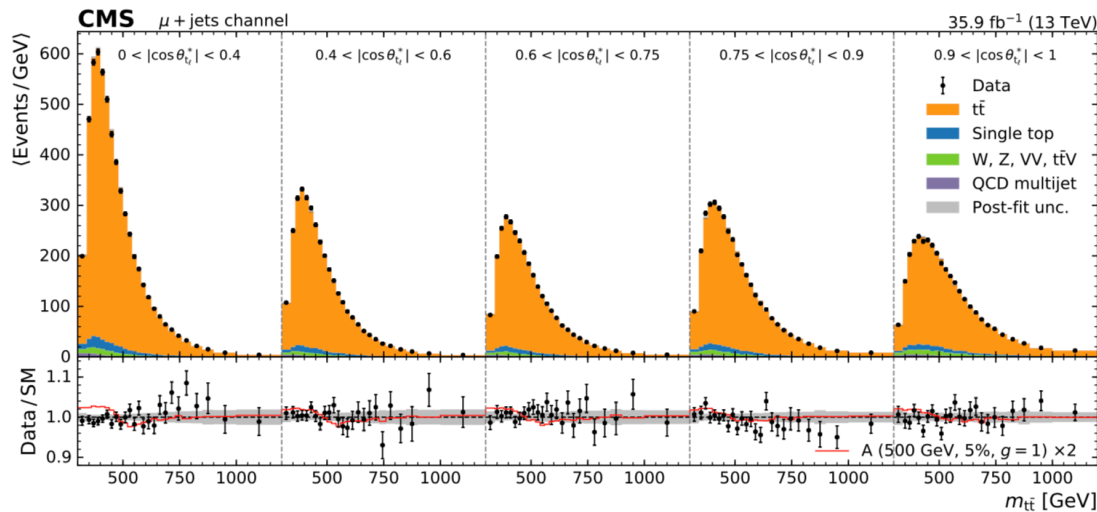
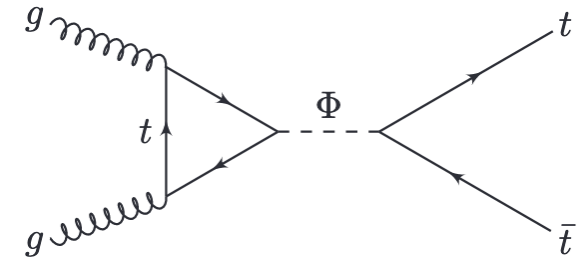

# $A \rightarrow Zh_{125} \rightarrow \ell\ell\tau\tau$

arXiv:1910.11634

## What if A is too light to decay to $t\bar{t}$ ?

- MSSM:  $B(A \rightarrow Zh) = 1$ , low  $\tan\beta$ ,  $m_A \sim 200\text{-}350\text{ GeV}$
- Reconstruct  $m_A$  with  $h_{125}$  constraint
- Cross section limits

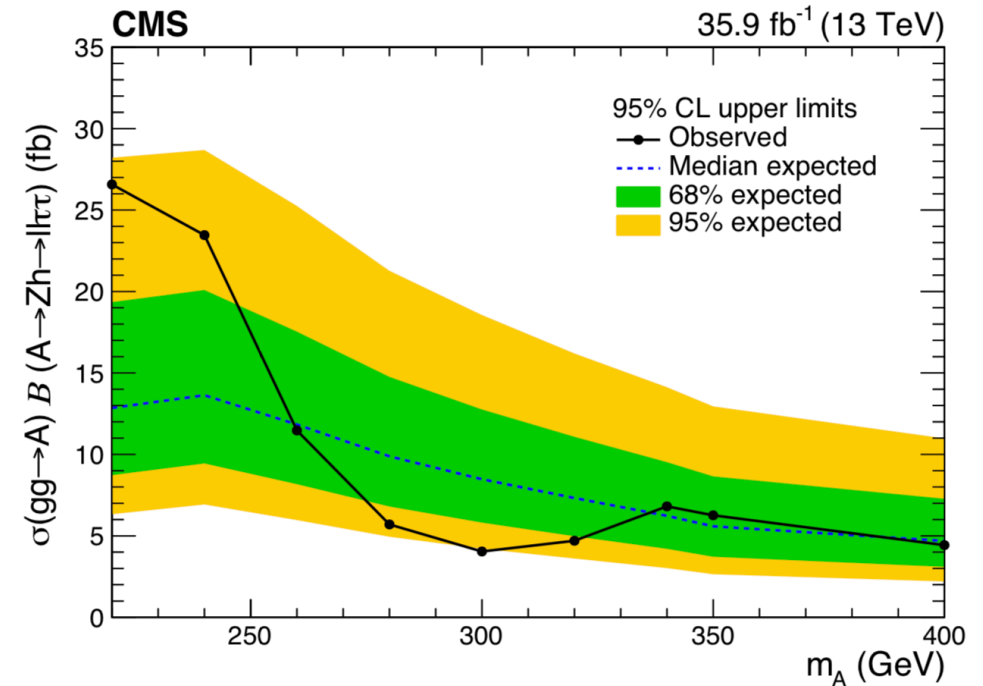
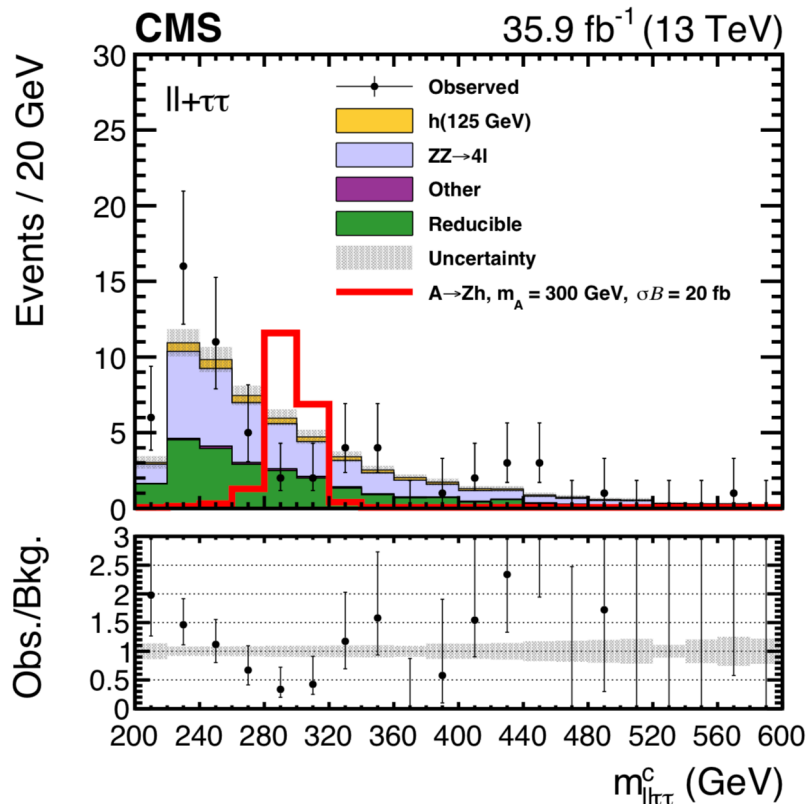
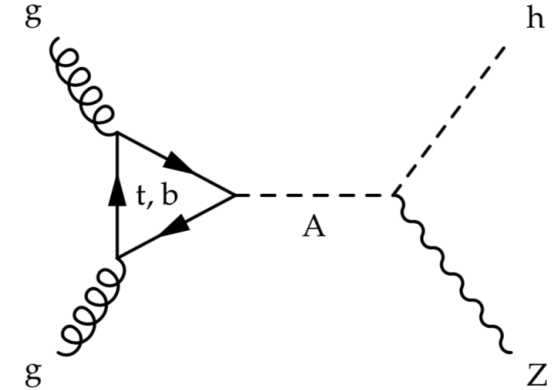

# di-Higgs searches

- Destructive interference in SM
- Could be altered in BSM
- If constructive, it could be large enhancement
- In SM, only  $\sigma=33\text{fb}$  at 13 TeV
- Study different final states

|                                  | BR                     | Mass scale |
|----------------------------------|------------------------|------------|
| $(X \rightarrow) hh \rightarrow$ | $bbbb$ 34%             | High       |
|                                  | $bb\tau\tau$ 7.3%      |            |
|                                  | $bbWW$ 27%             |            |
|                                  | $bb\gamma\gamma$ 0.26% | Low        |

non-resonant production

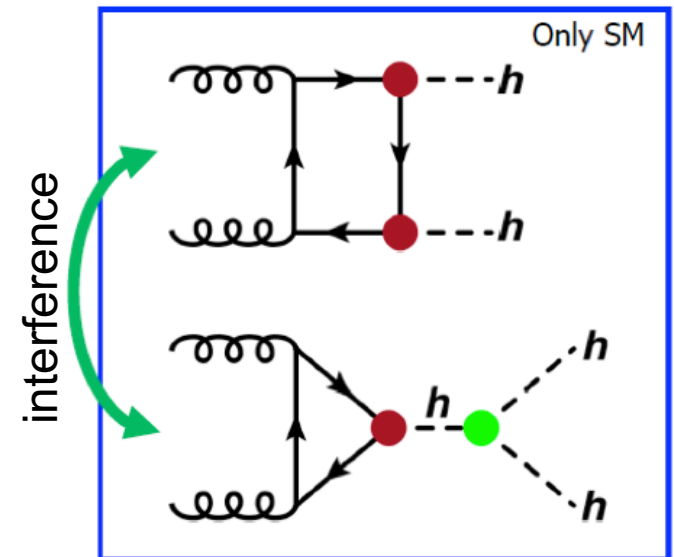

resonant production

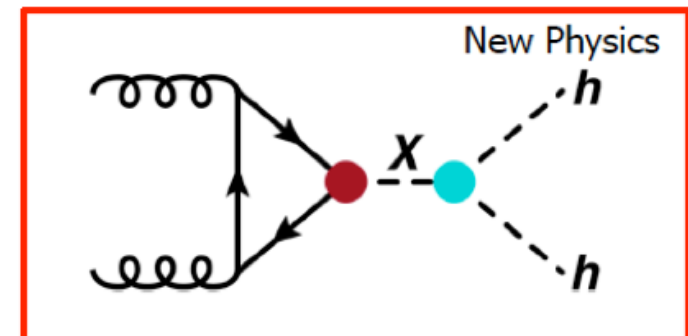

# Double Higgs production

PRL 122(2018)121803

- Study different final states
- Not yet at the SM sensitivity

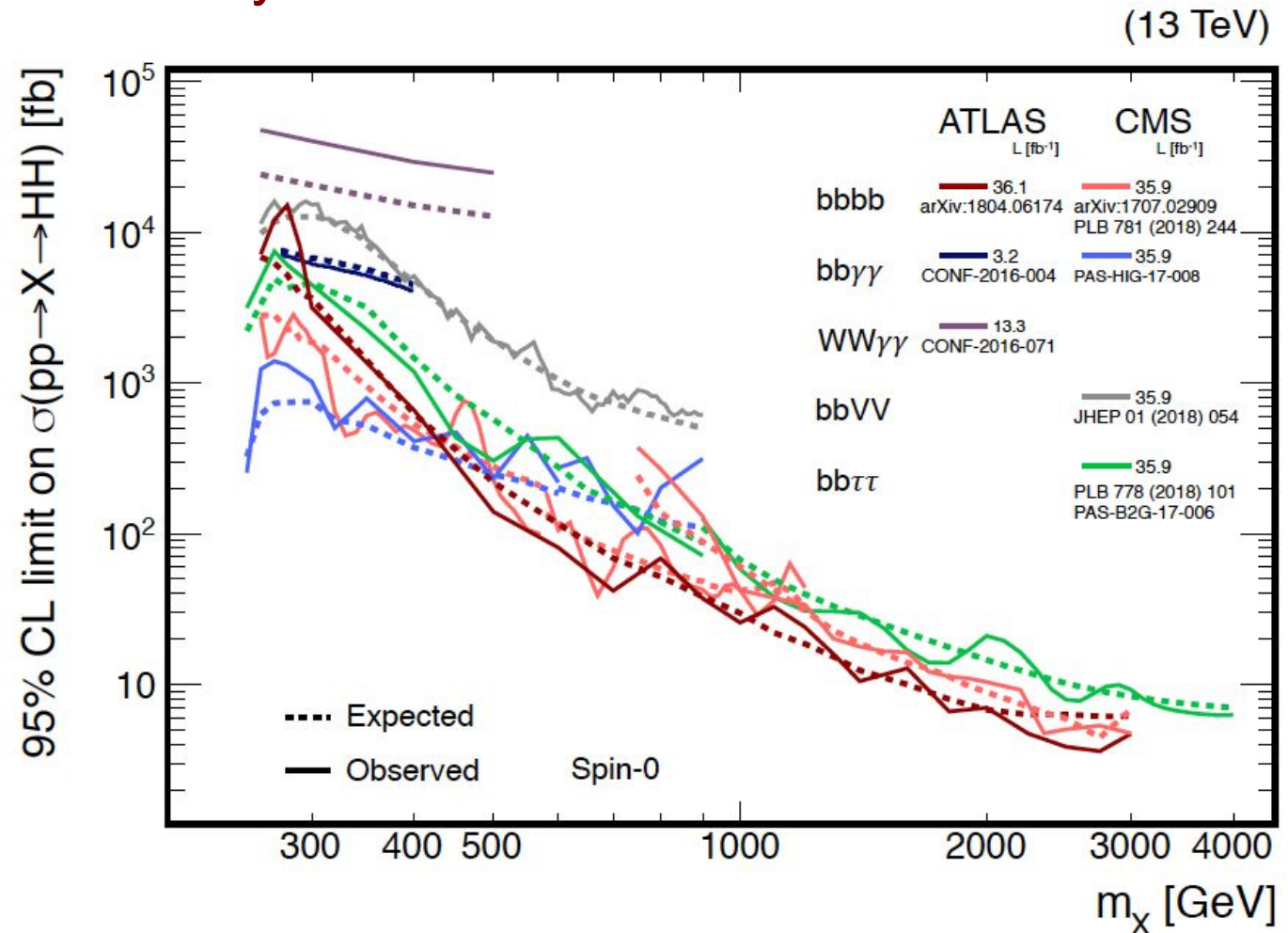

# Advanced Analysis Techniques

arXiv:1902.00134

Use advanced analysis techniques to improve sensitivity

- 1) Select **HH** events in different categories:  $\mu\tau_h bb$ ,  $e\tau_h bb$ , and  $\tau_h\tau_h bb$
- 2) Train classifier consisting of an ensemble of **deep neural networks (DNN)** on half of MC data to classify signal and background events using final-state features
- 3) Apply classifier to other half of MC data
- 4) Treat the classifier **prediction** as a summary statistic of the data and infer the signal strength via a combined hypothesis test for each decay-channel category
- 5) 52 pre-processed features are used to define each event

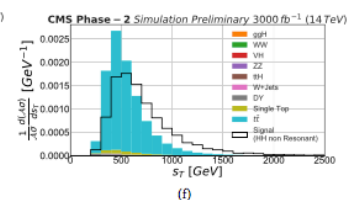
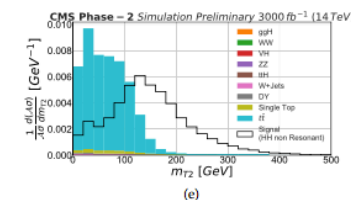
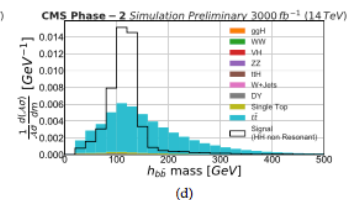
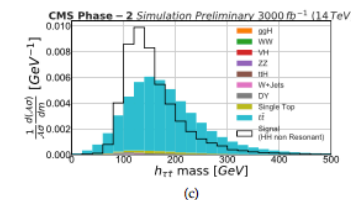
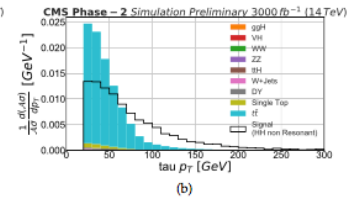
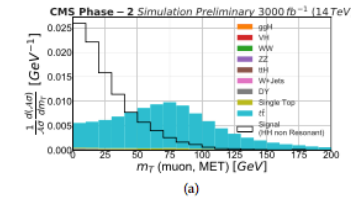
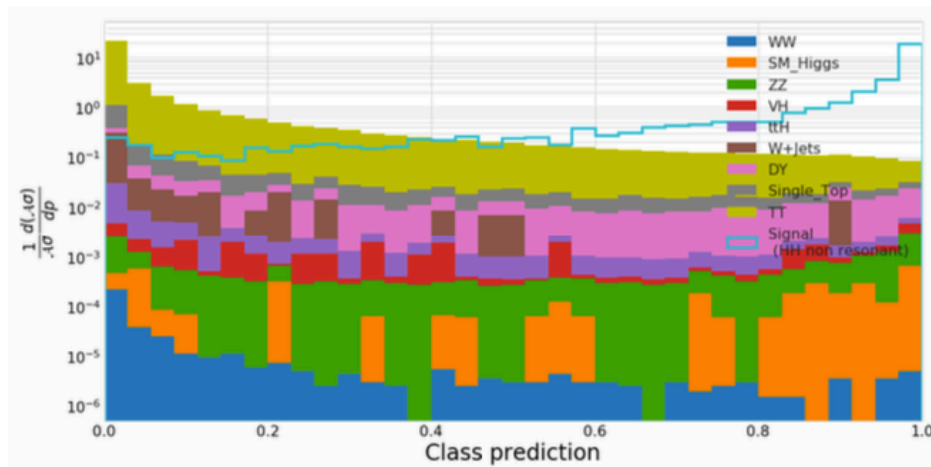

# LFV in Higgs decays

PLB 763(2016)472, arXiv:1911.10267

- Some BSM models allow for LFV Higgs decays
- Search for  $H \rightarrow e\tau$ ,  $e\mu$ ,  $\mu\tau$  final states
- Categories:  $N_{\text{jet}}$ , lepton kinematics
  - $N_{\text{jet}}$  to target ggH and VBF production
- Main background from DY, ttbar, WW

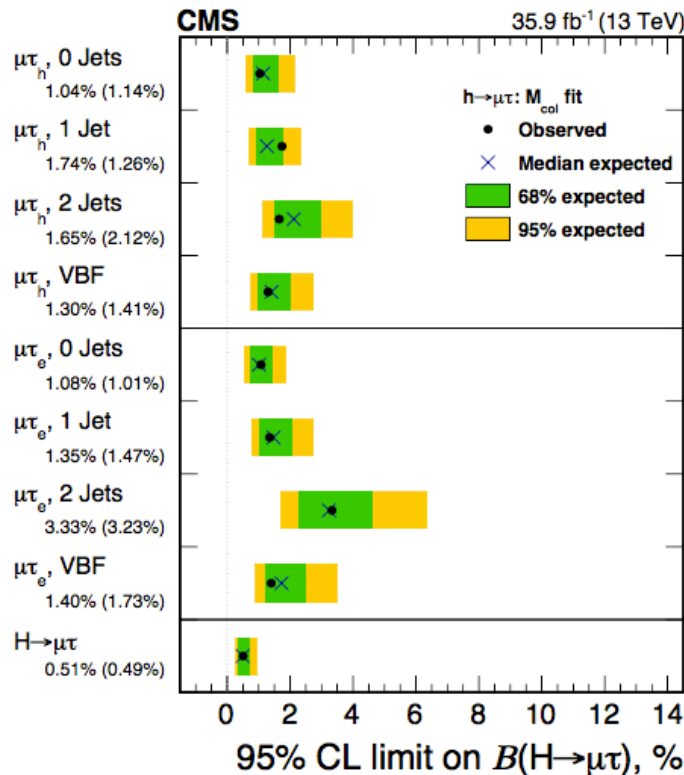
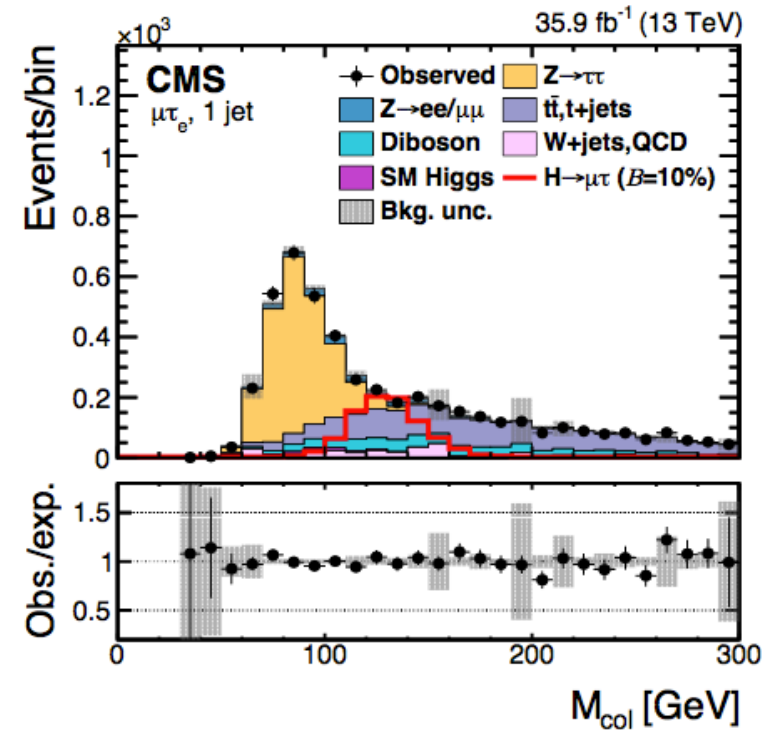

|                         | Observed (expected) limits (%) |                      | Best fit branching fraction (%) |                      |
|-------------------------|--------------------------------|----------------------|---------------------------------|----------------------|
|                         | BDT fit                        | $M_{\text{col}}$ fit | BDT fit                         | $M_{\text{col}}$ fit |
| $H \rightarrow \mu\tau$ | $<0.25$ (0.25)%                | $<0.51$ (0.49) %     | $0.00 \pm 0.12$ %               | $0.02 \pm 0.20$ %    |
| $H \rightarrow e\tau$   | $<0.61$ (0.37) %               | $<0.72$ (0.56) %     | $0.30 \pm 0.18$ %               | $0.23 \pm 0.24$ %    |

# DM searches with Higgs bosons

- H(125) may mix with new dark mediators
- Signature: Higgs+MET  $\Rightarrow$  H used as a tag
- Final states:
  - $H \rightarrow b\bar{b} \sim 58\%$ , large bkg
  - $H \rightarrow W^+W^- \sim 21\%$ , moderate bkg
  - $H \rightarrow \tau\tau \sim 6\%$ , lower bkg
  - $H \rightarrow \gamma\gamma \sim 0.2\%$ , clean final state

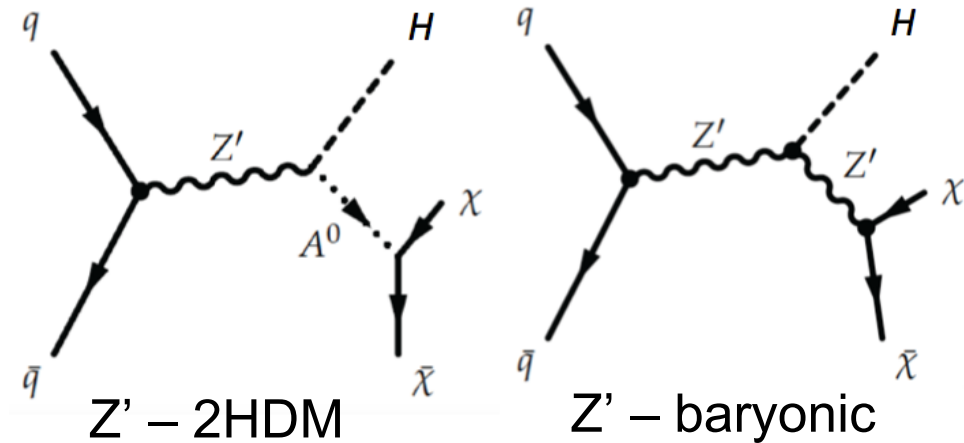



# Higgs + Dark Matter

arXiv:1908.01713

- Generic search:  $pp \rightarrow H + \text{MET}$ 
  - ISR suppressed due to small coupling to H
  - In the context of simplified models
- DM search with  $H(\rightarrow bb, \gamma\gamma, ZZ, WW, \tau\tau)$
- Signal events at large MET

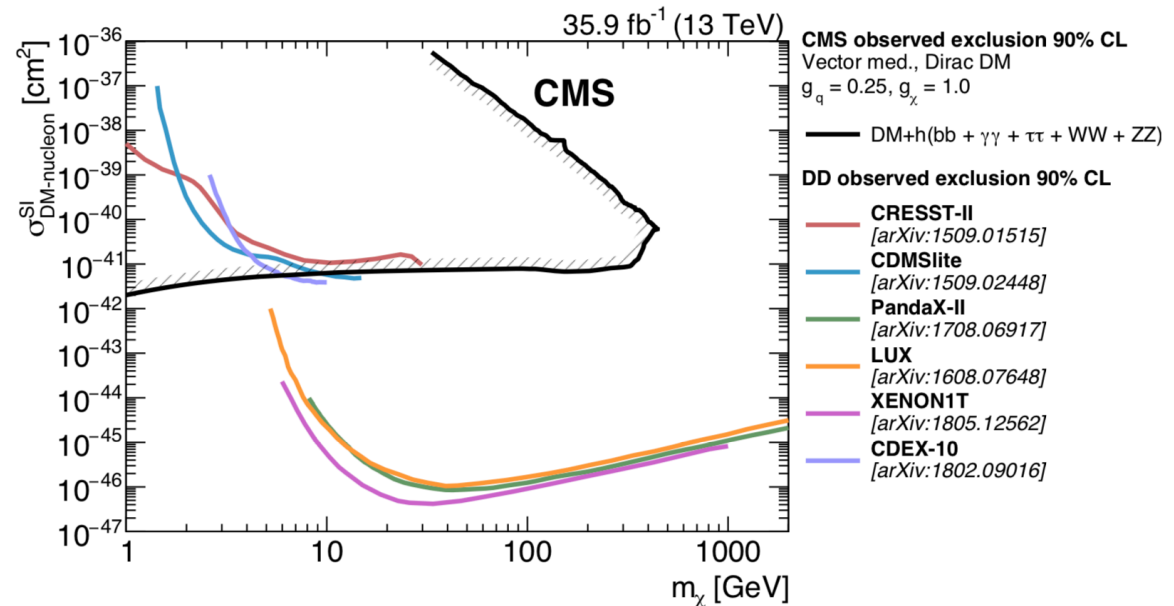
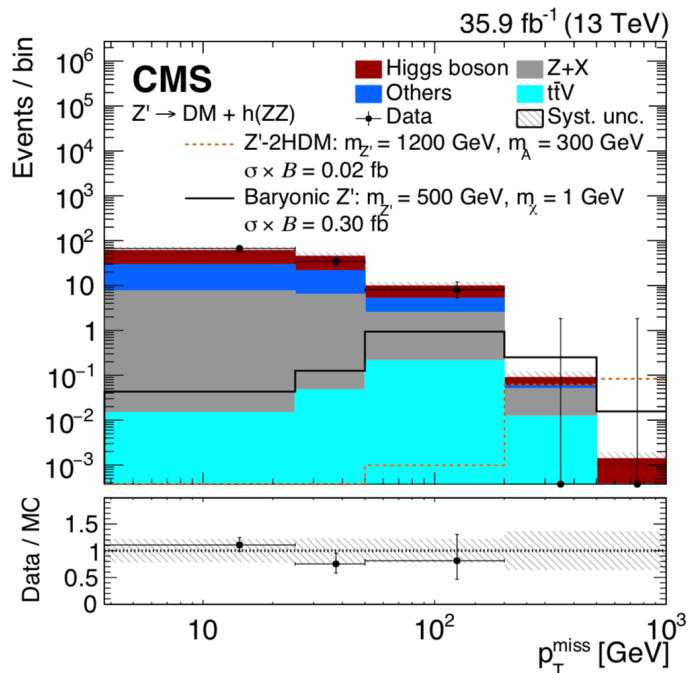
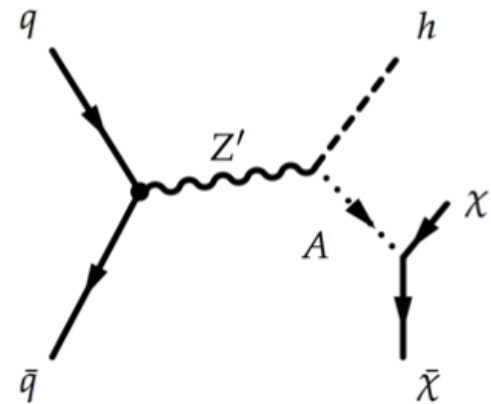

# VBF: H(invisible)

arXiv:1809.06682, arXiv:1809.05937

- Signature: Large MET,  $\Delta\phi(jj)$ , veto  $\ell/b$ -jets
  - C&C and shape fit of  $m(jj)$
- Main bkg: V+jets (95%)
- Tag with forward jets+MET
- Cross section  $\sim 4\text{pb}$
- Small background
- Most sensitive

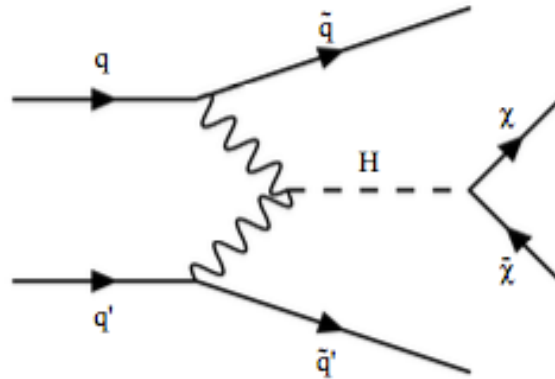

Shape: bkg-only fit in CRs+SR  
35.9 fb<sup>-1</sup> (13 TeV)

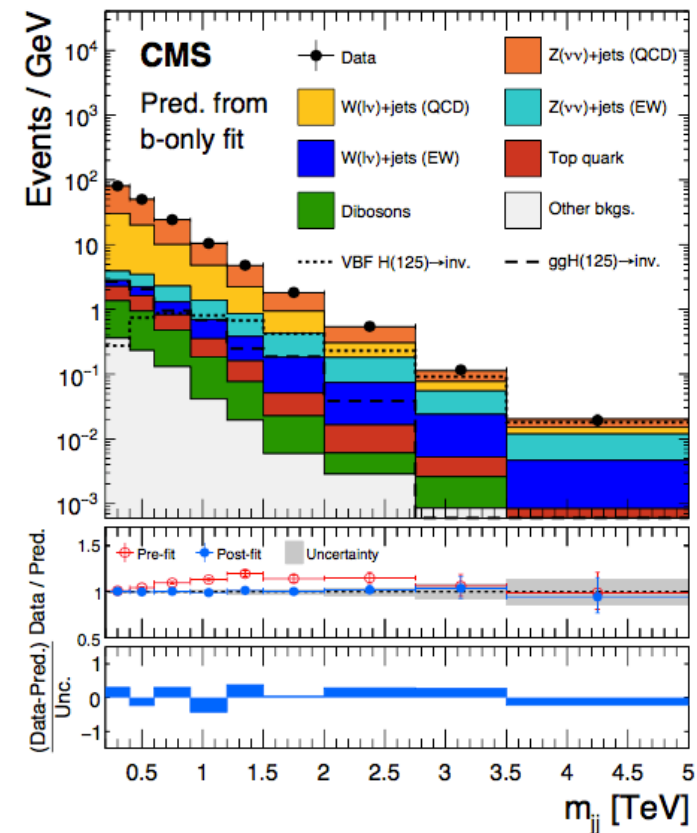

Set limits:  $B(H \rightarrow \text{inv.}) < 0.37$  (0.28) @95%CL

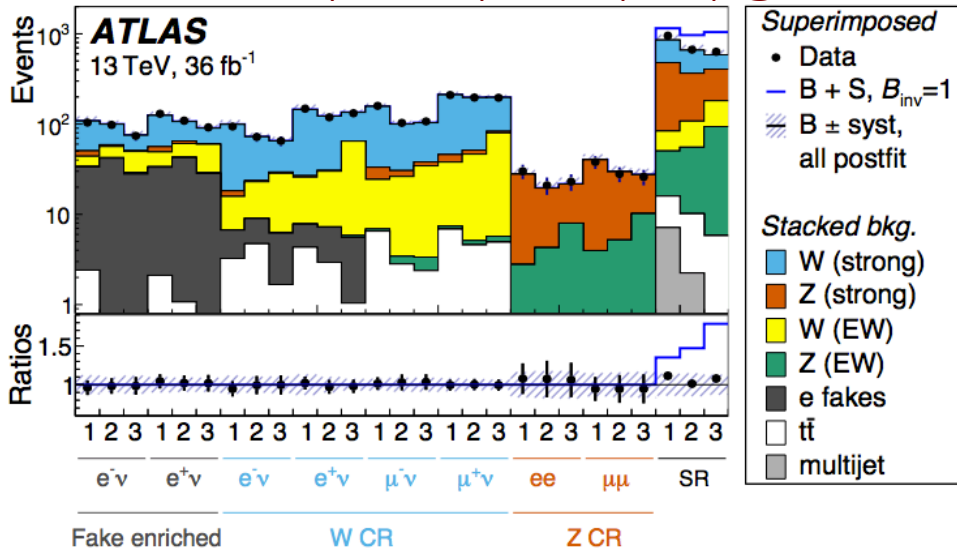

# Summary

- Excellent consistency of SM but **SM is incomplete**
- Extensions foresee existence of additional bosons
- Searches for BSM bosons natural companion to precision SM Higgs boson measurements
  - Charged Higgs searches with top quark decays
  - Other BSM searches show no indication of deviations
- Searches provide **no hints for BSM yet**



# Couplings (cont.)

arXiv:1809.10733

