



9th International Conference on
New Frontiers in Physics (ICNFP 2020)

A WHOLE WORLD LIES BETWEEN
QUANTUM NON-LOCALITY
AND COMMUNICATION

Claude Crépeau



McGill

- Information theoretical model.
- What is Signalling?
- What is No-Signalling?
- Quantum Mechanics
- Special Relativity
- Future work

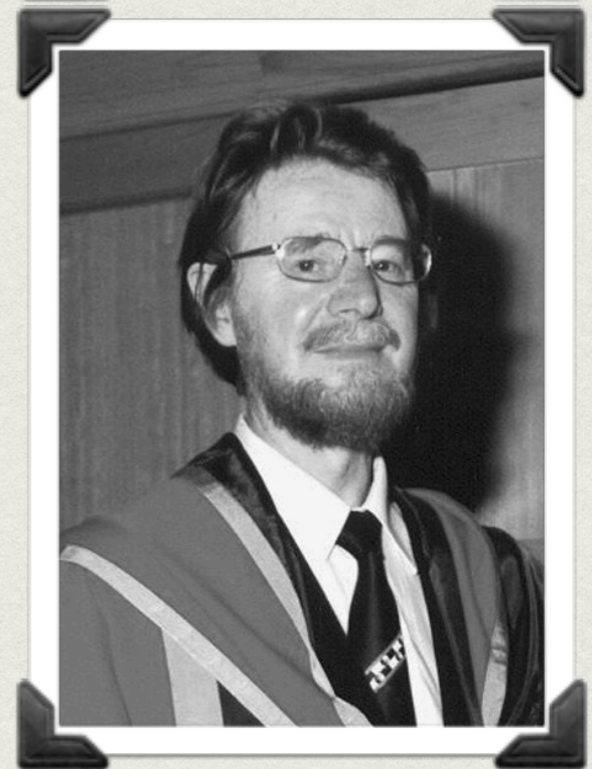
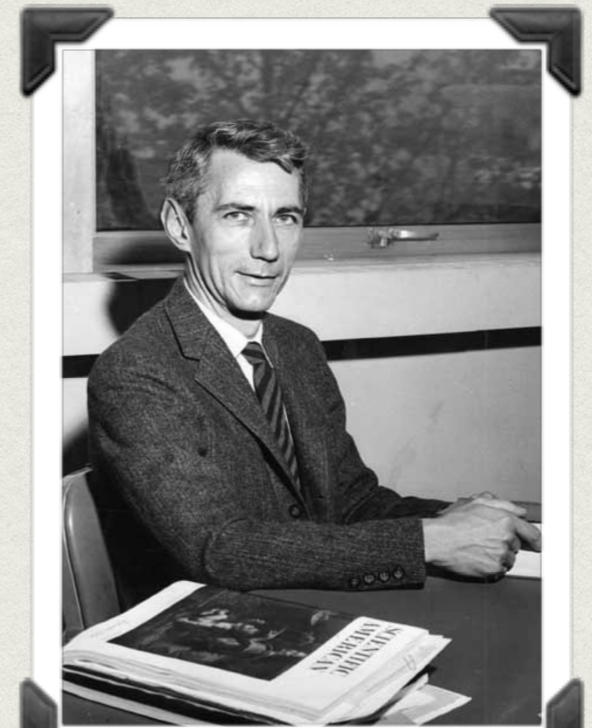

INTRODUCTION

DISCRETE CHANNELS

DISCRETE CHANNELS

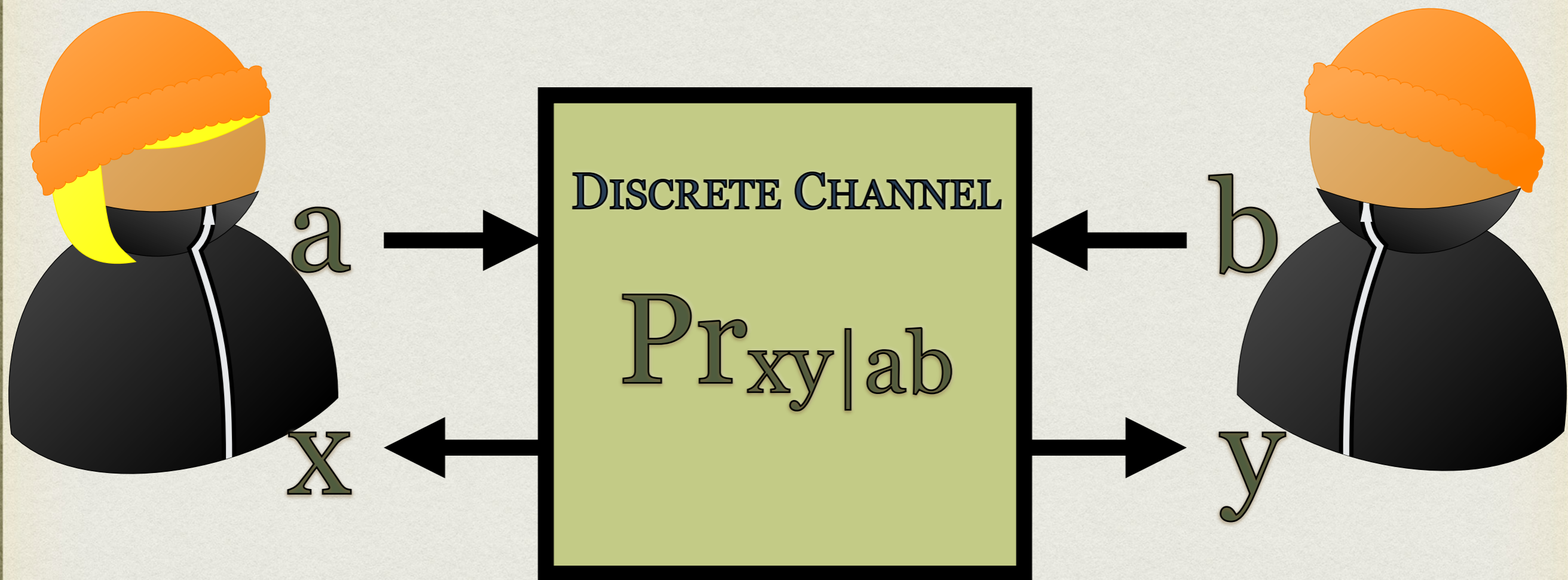

DISCRETE CHANNELS

A, B, X, Y : finite sets

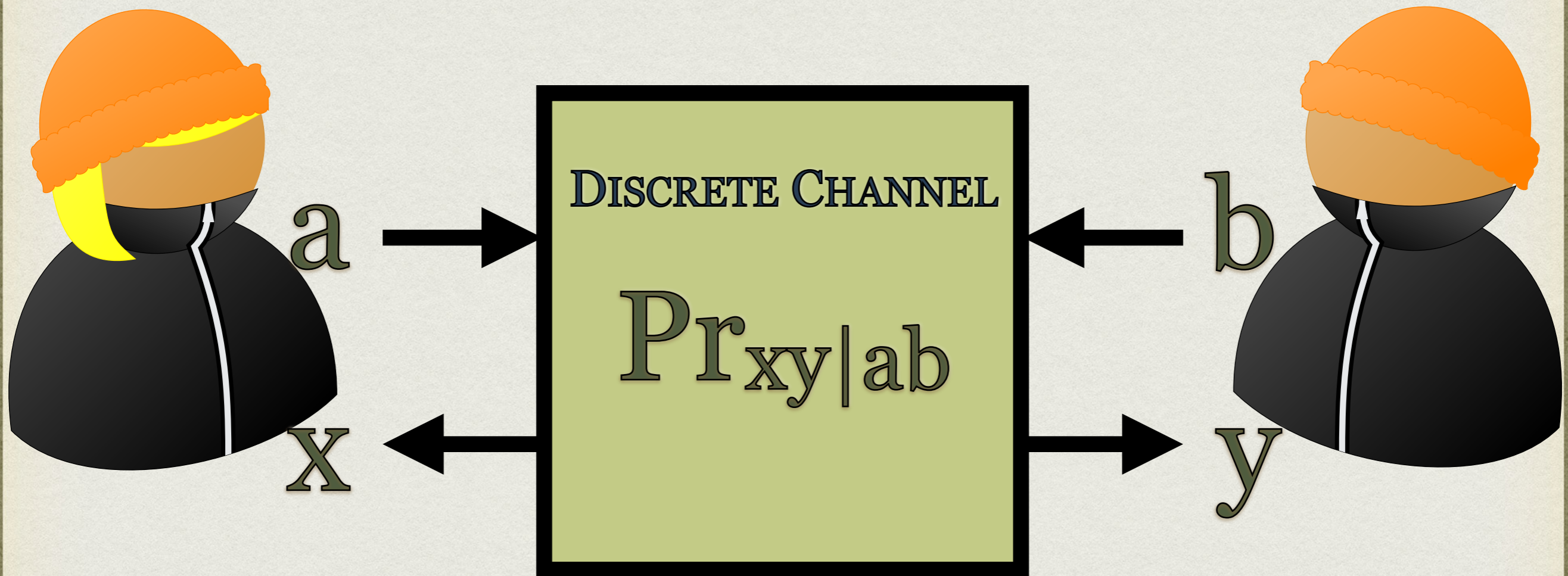

DISCRETE CHANNELS

A, B, X, Y : finite sets
 $a \in A, b \in B, x \in X, y \in Y$

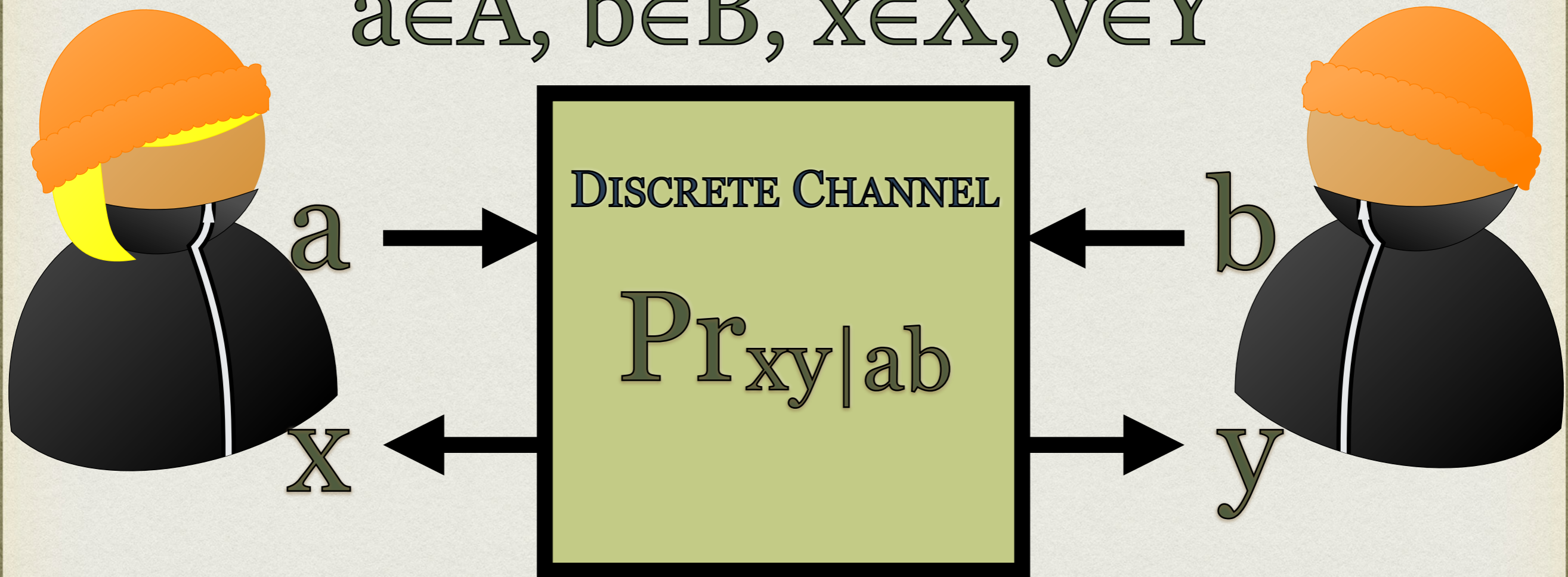

GENERAL CHANNELS

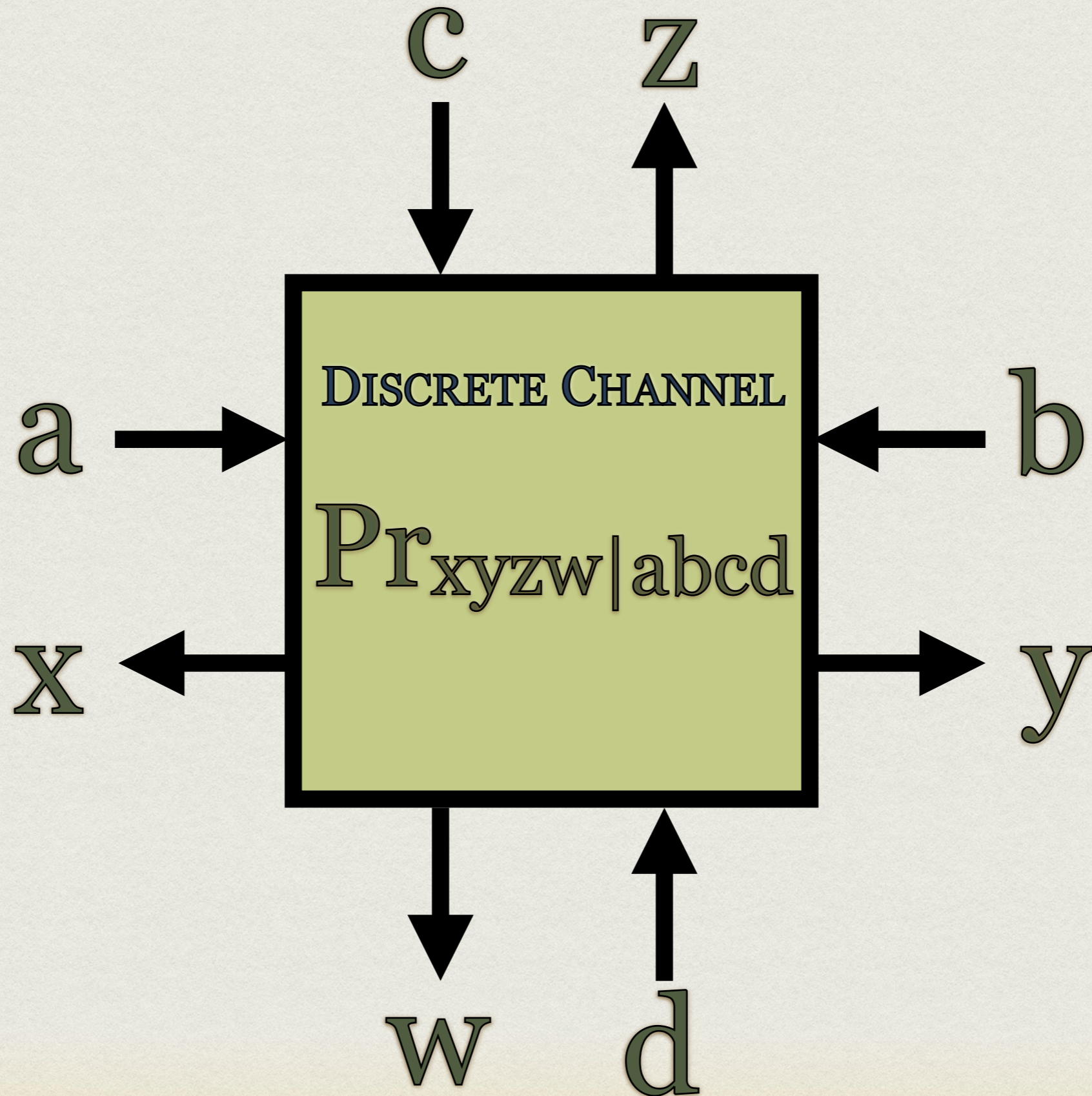

DISCRETE CHANNELS

$$X=A, Y=B$$

$$x=a, y=b$$

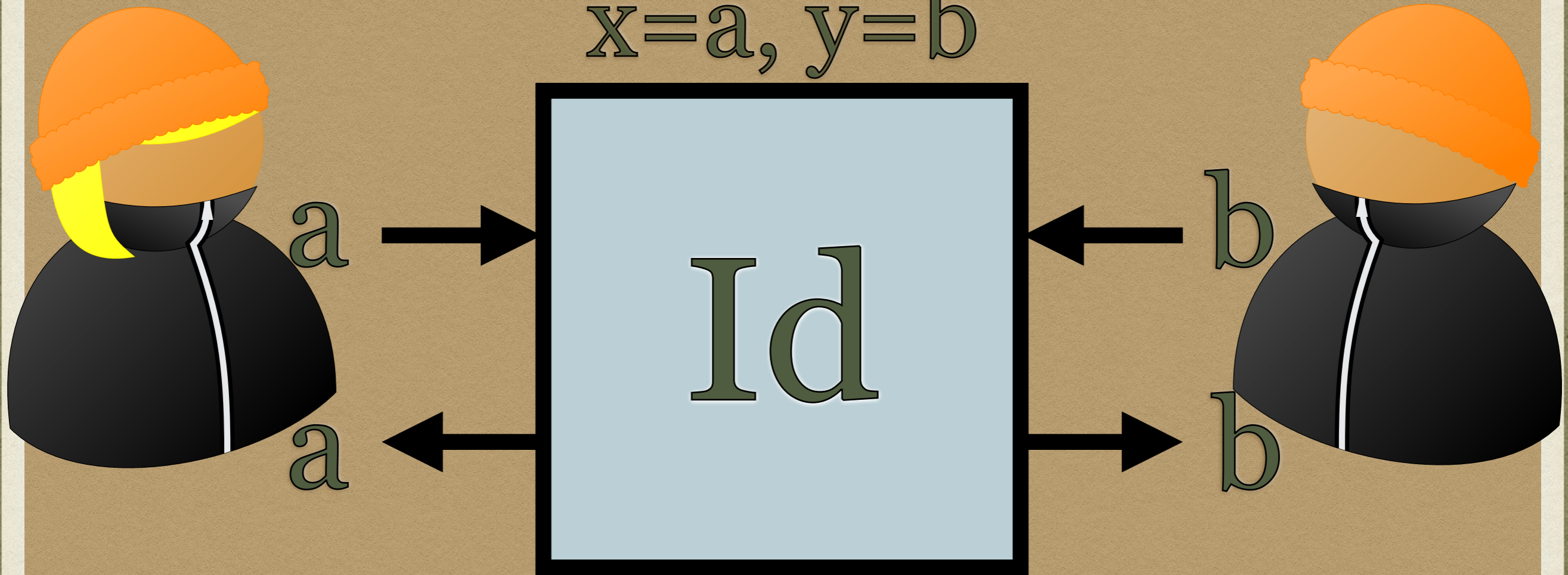

DISCRETE CHANNELS

$$X=B, Y=A$$

$$x=b, y=a$$

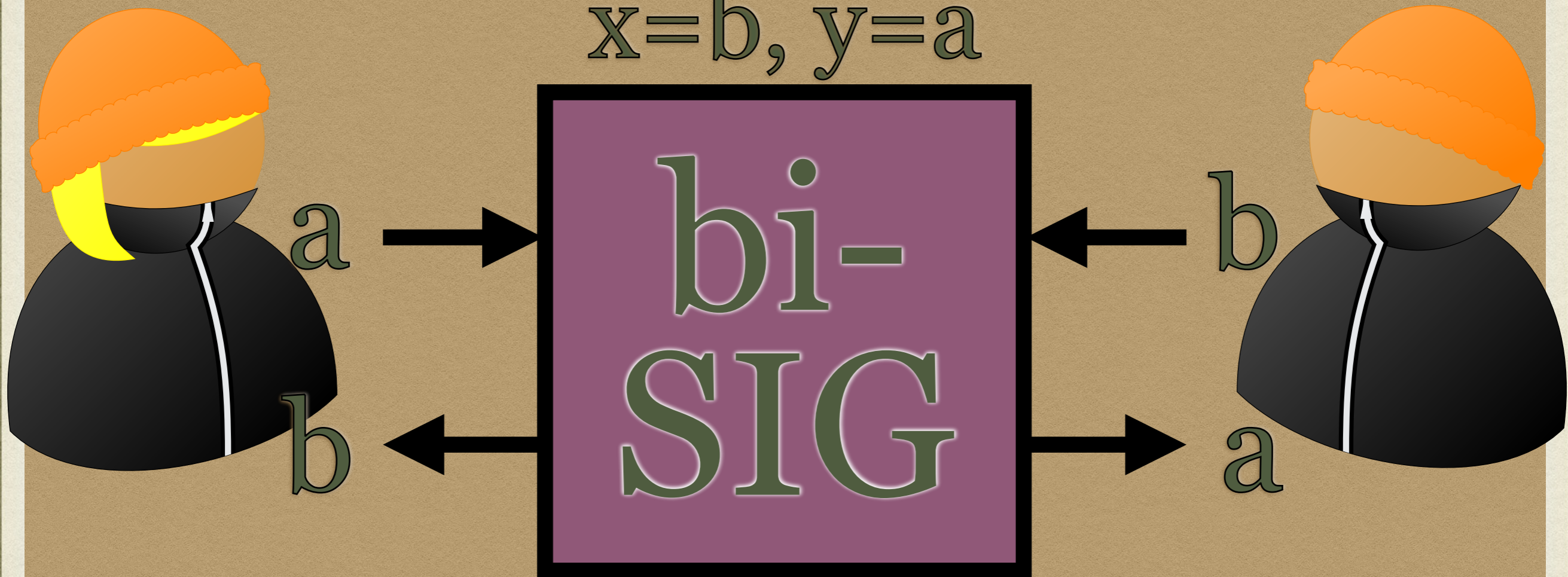

DISCRETE CHANNELS

$$X=Y=A$$

$$x=y=a$$

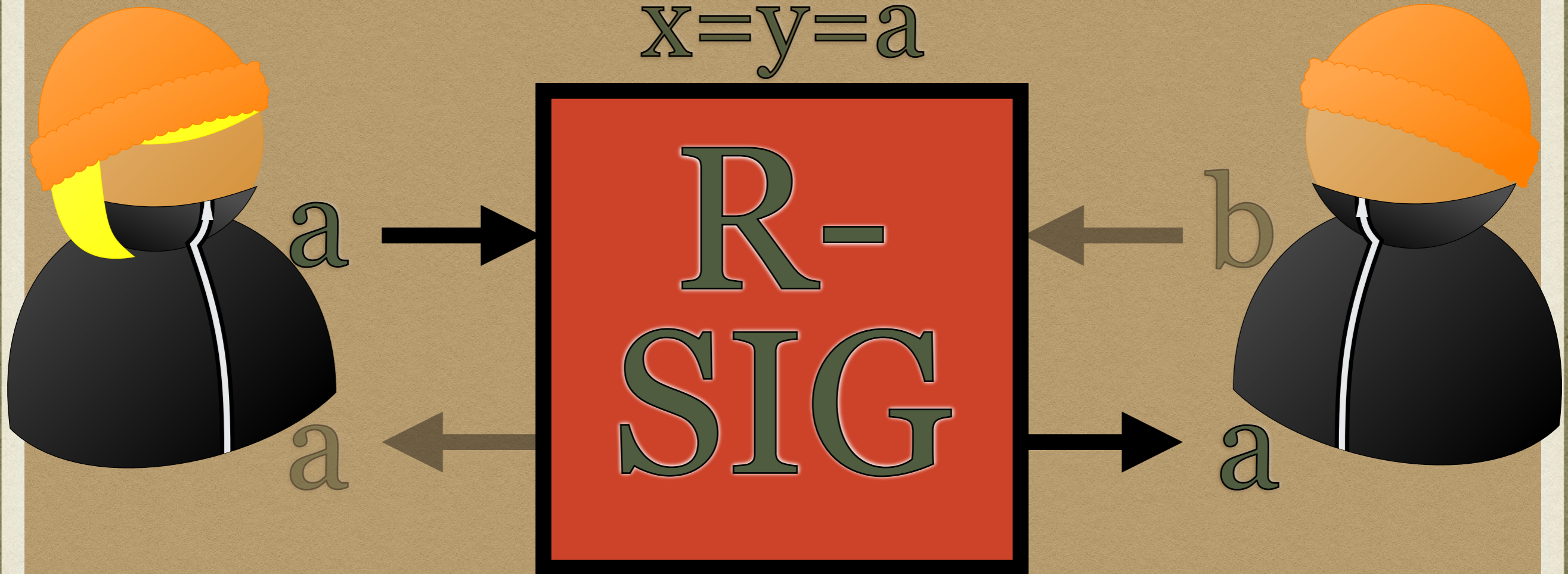

DISCRETE CHANNELS

$$X=Y=B$$

$$x=y=b$$



DISCRETE CHANNELS

$$A=B=X=Y=\mathbb{F}$$

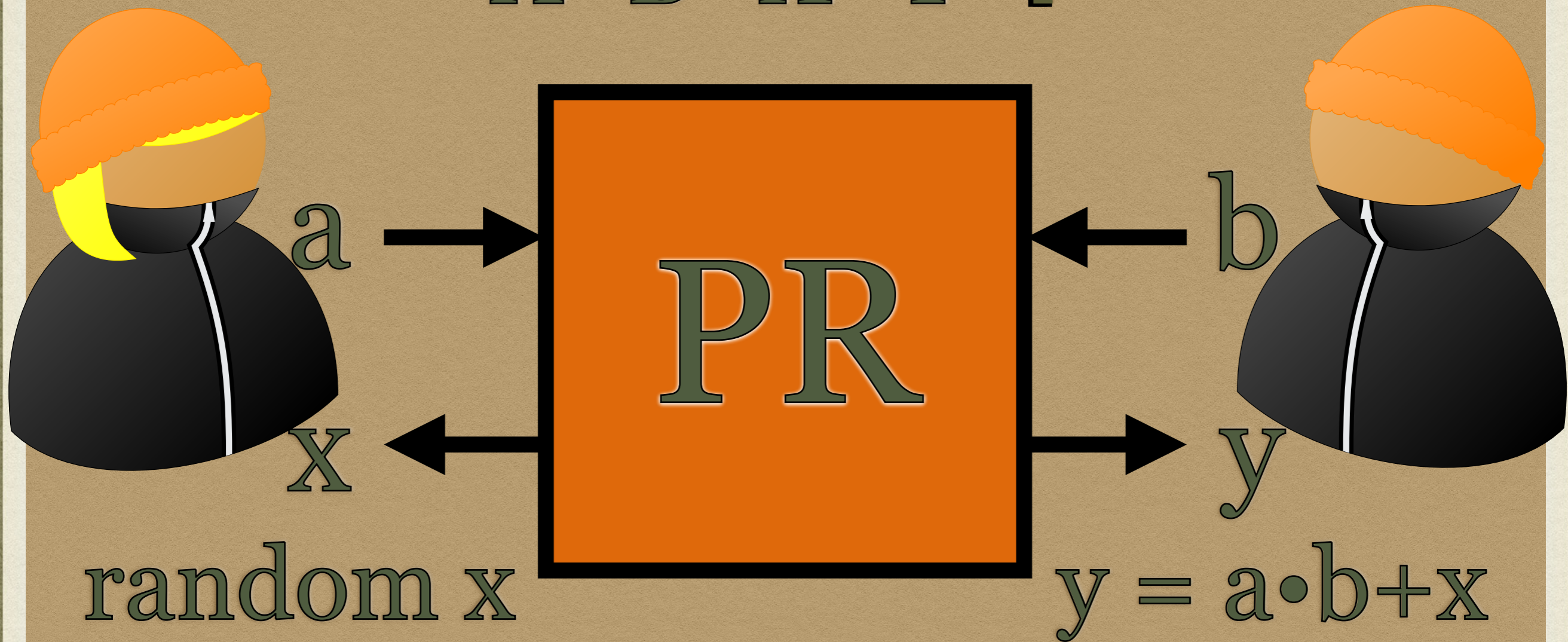

DISCRETE CHANNELS

$$A=B=X=Y=\{\text{red}, \text{green}, \text{blue}\}$$

$$a \neq x \neq y \neq b$$

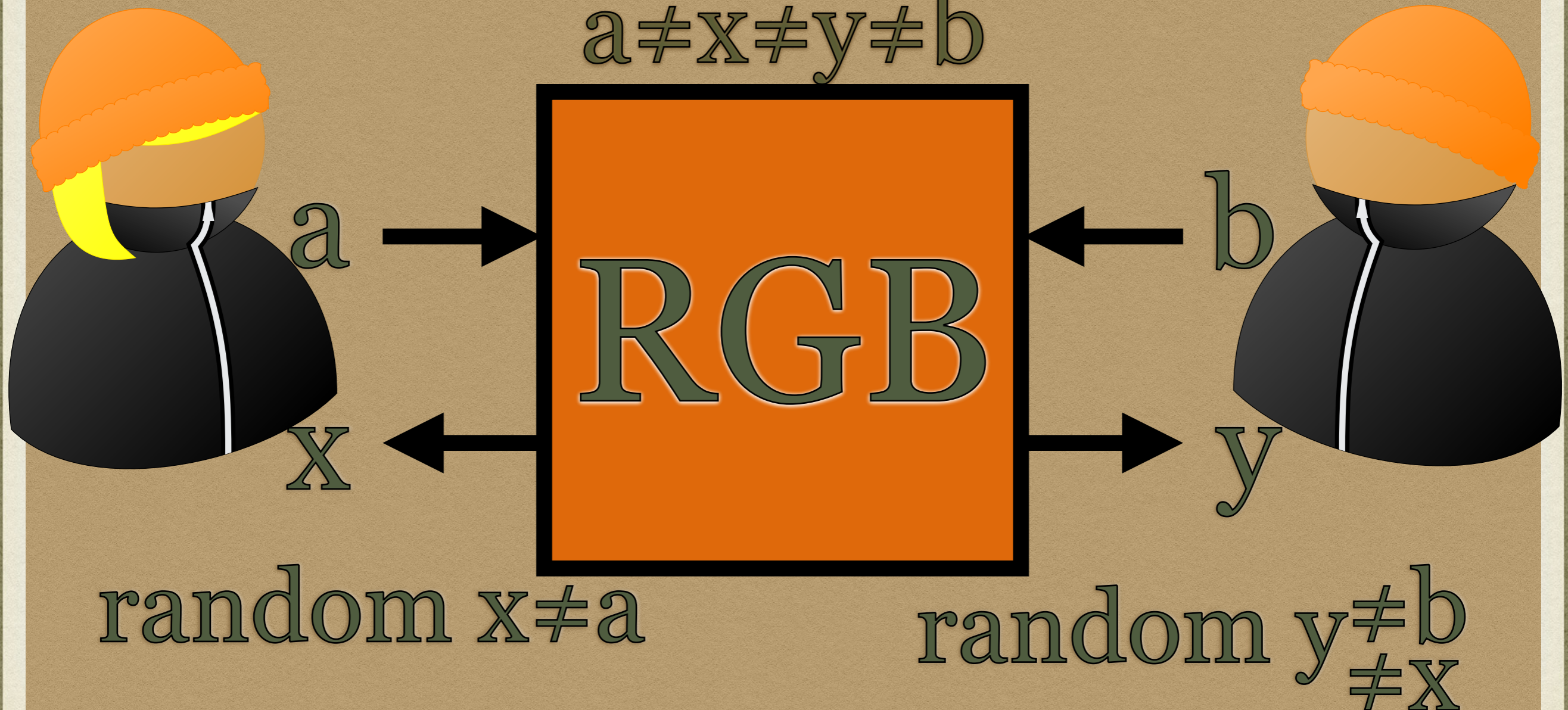

WHAT CONSTITUTES A SIGNALLING CHANNEL?



WHAT CONSTITUTES A
SIGNALLING CHANNEL?

WHAT CONSTITUTES A SIGNALLING CHANNEL?



WHAT CONSTITUTES A SIGNALLING CHANNEL?



WHAT CONSTITUTES A SIGNALLING CHANNEL?

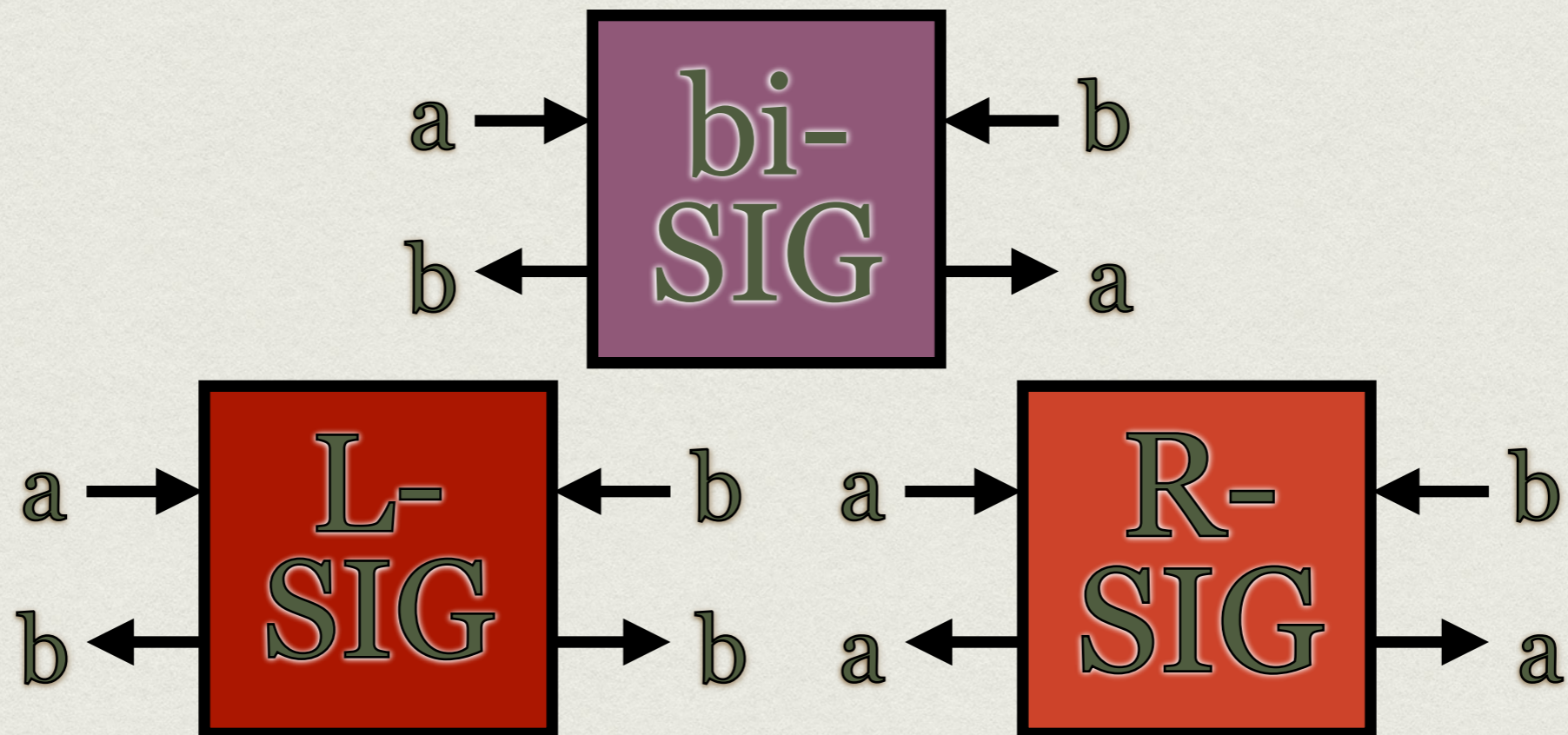

WHAT CONSTITUTES A SIGNALLING CHANNEL?

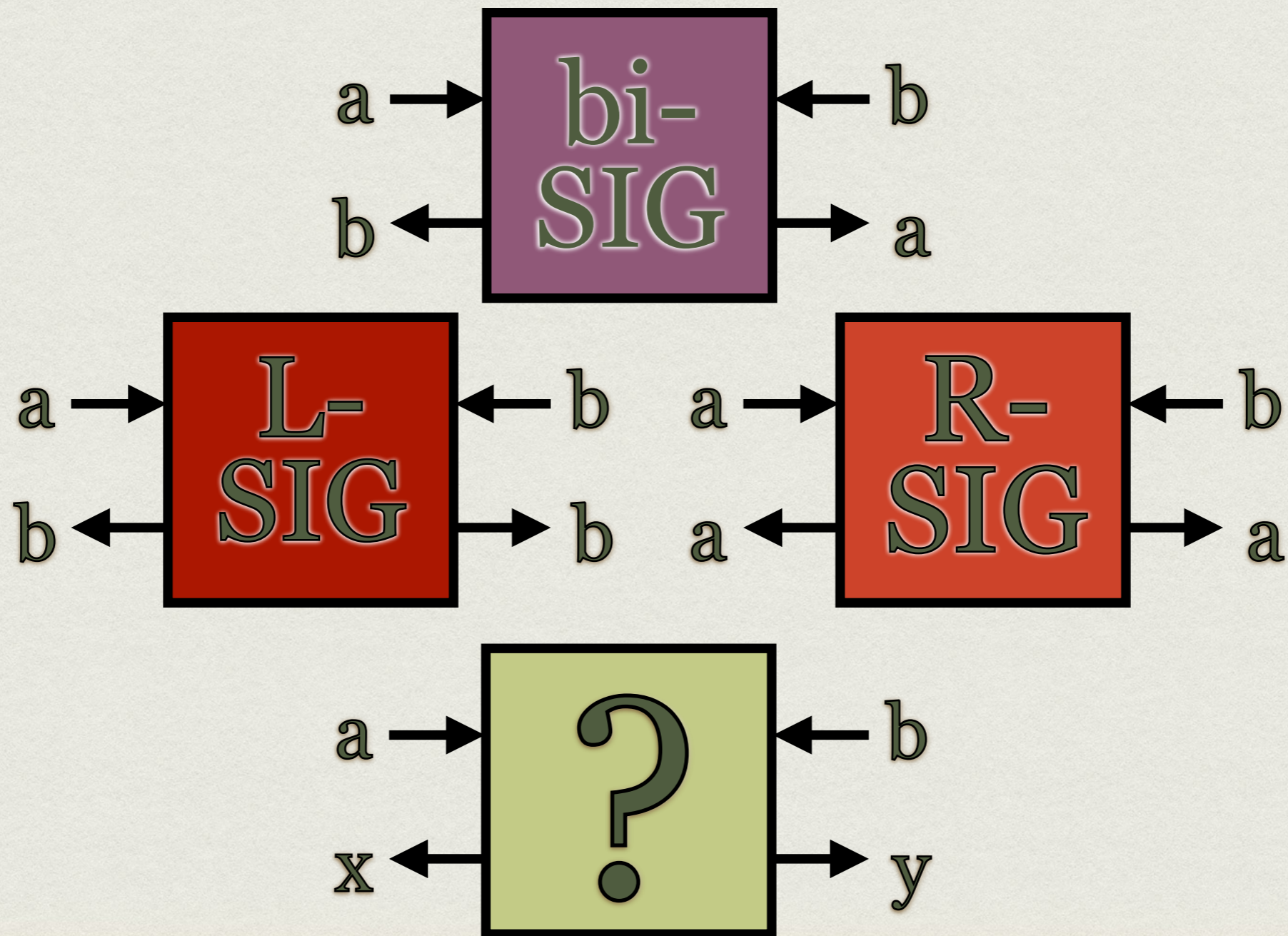

WHAT CONSTITUTES A SIGNALLING CHANNEL CHANNEL?

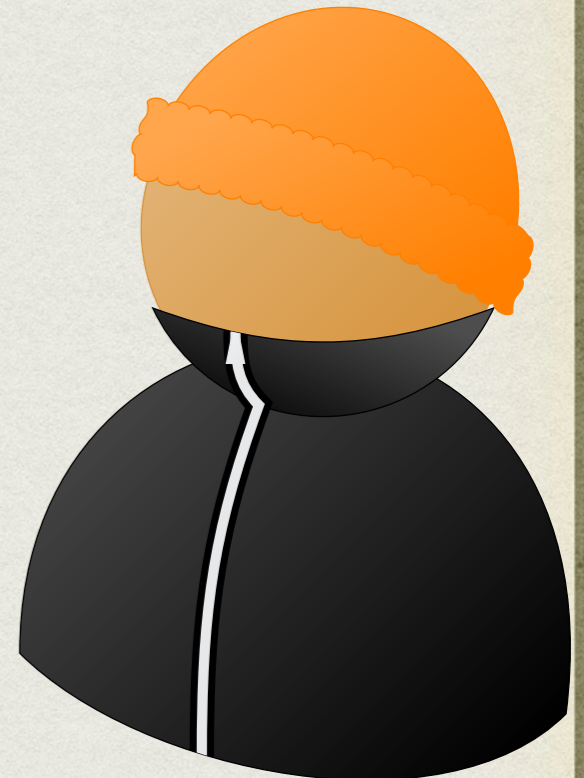
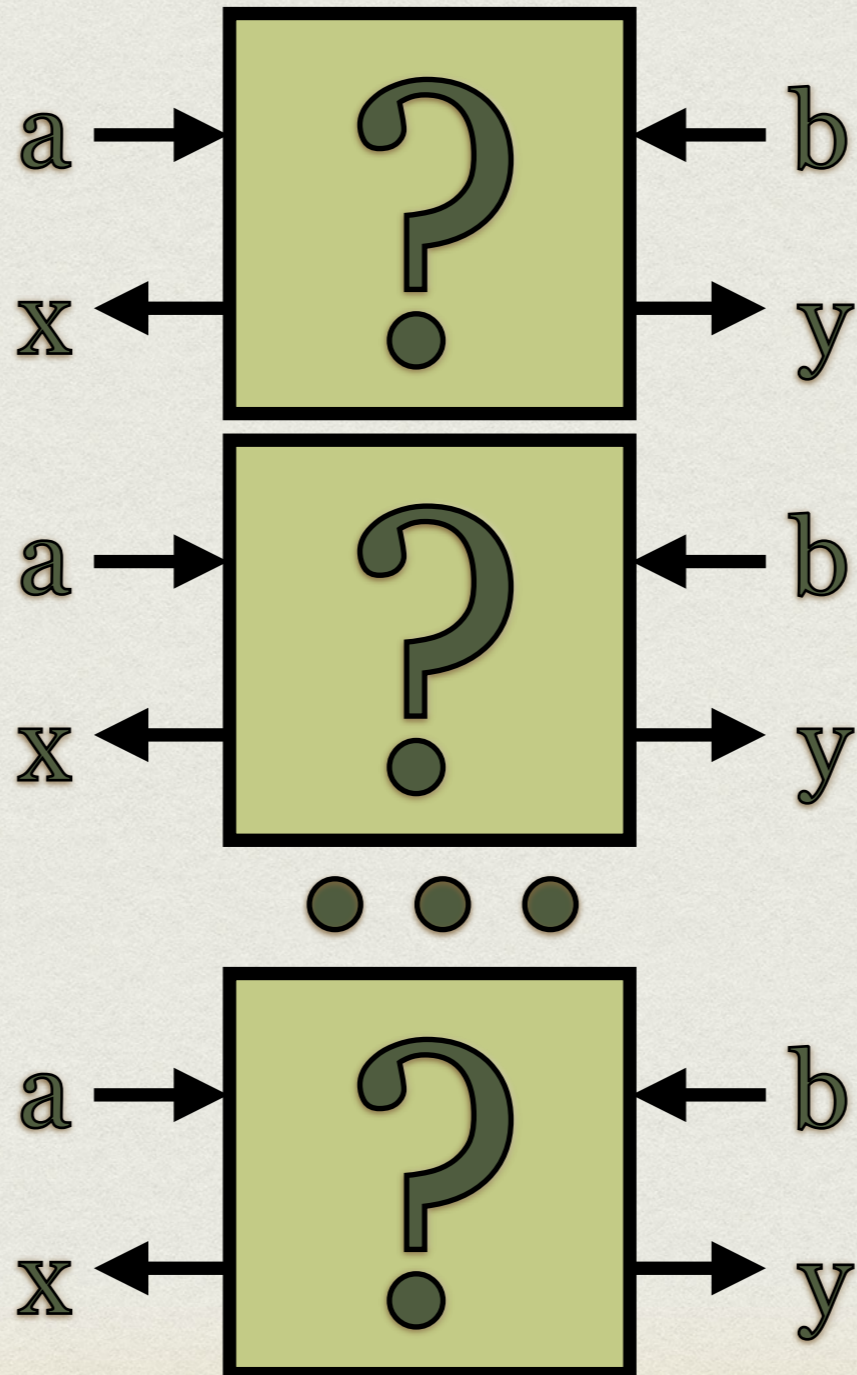
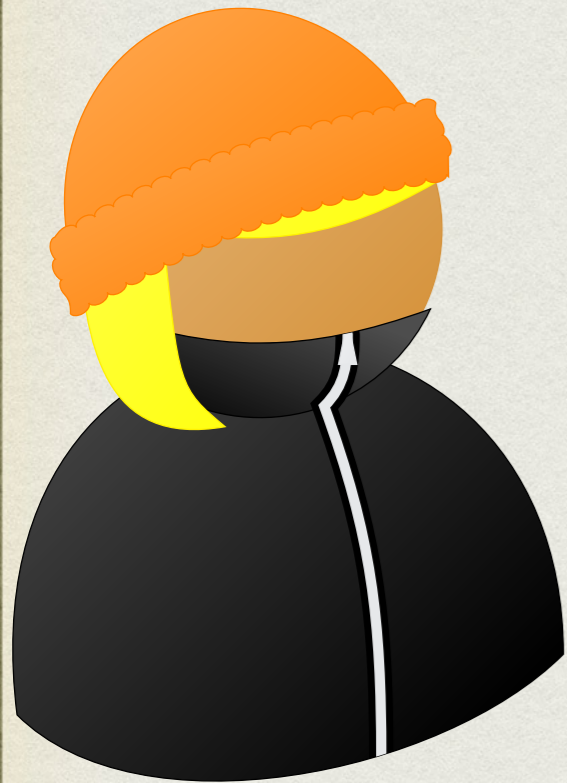

WHAT CONSTITUTES A SIGNALLING CHANNEL CHANNEL?

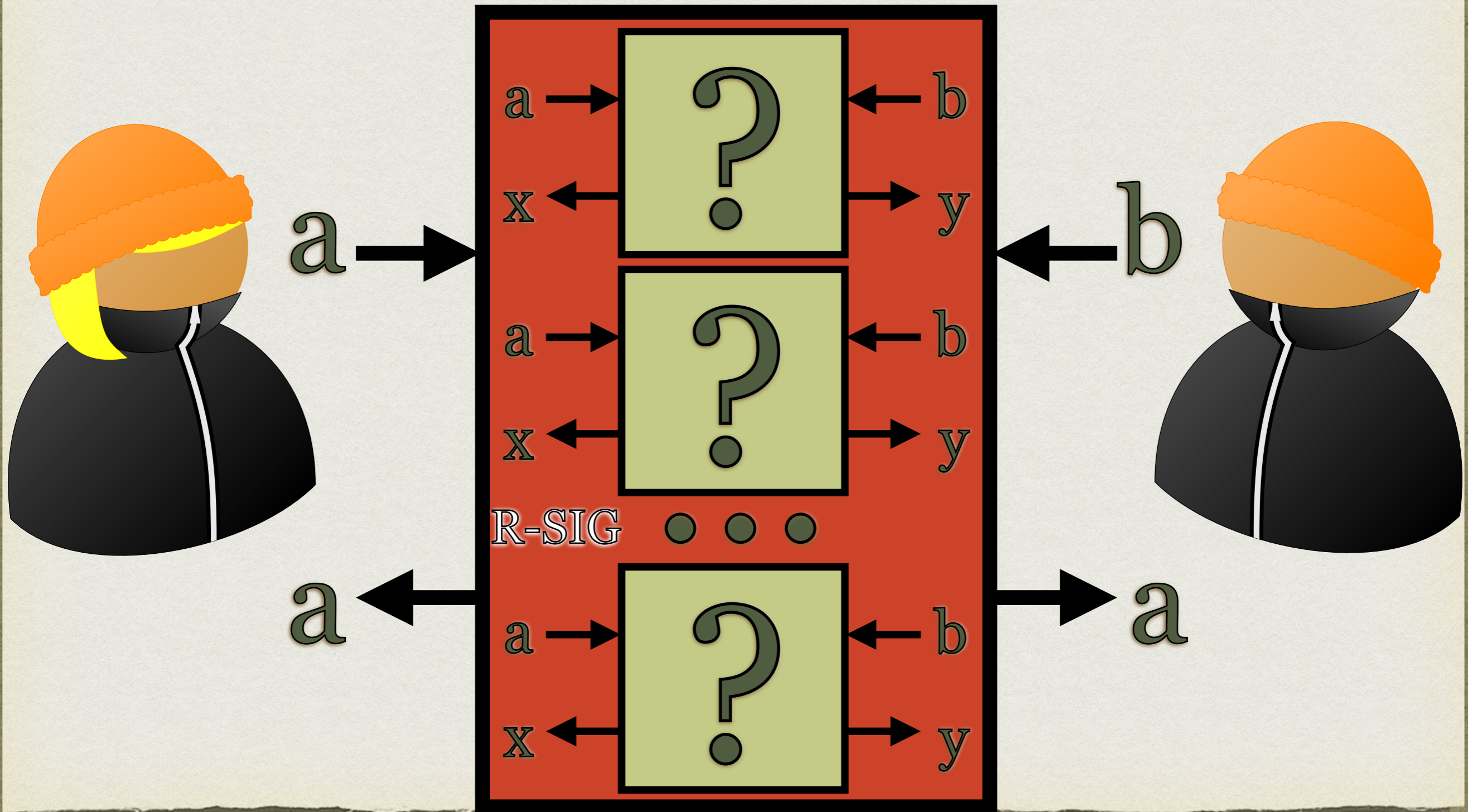

WHAT CONSTITUTES A SIGNALLING CHANNEL CHANNEL?

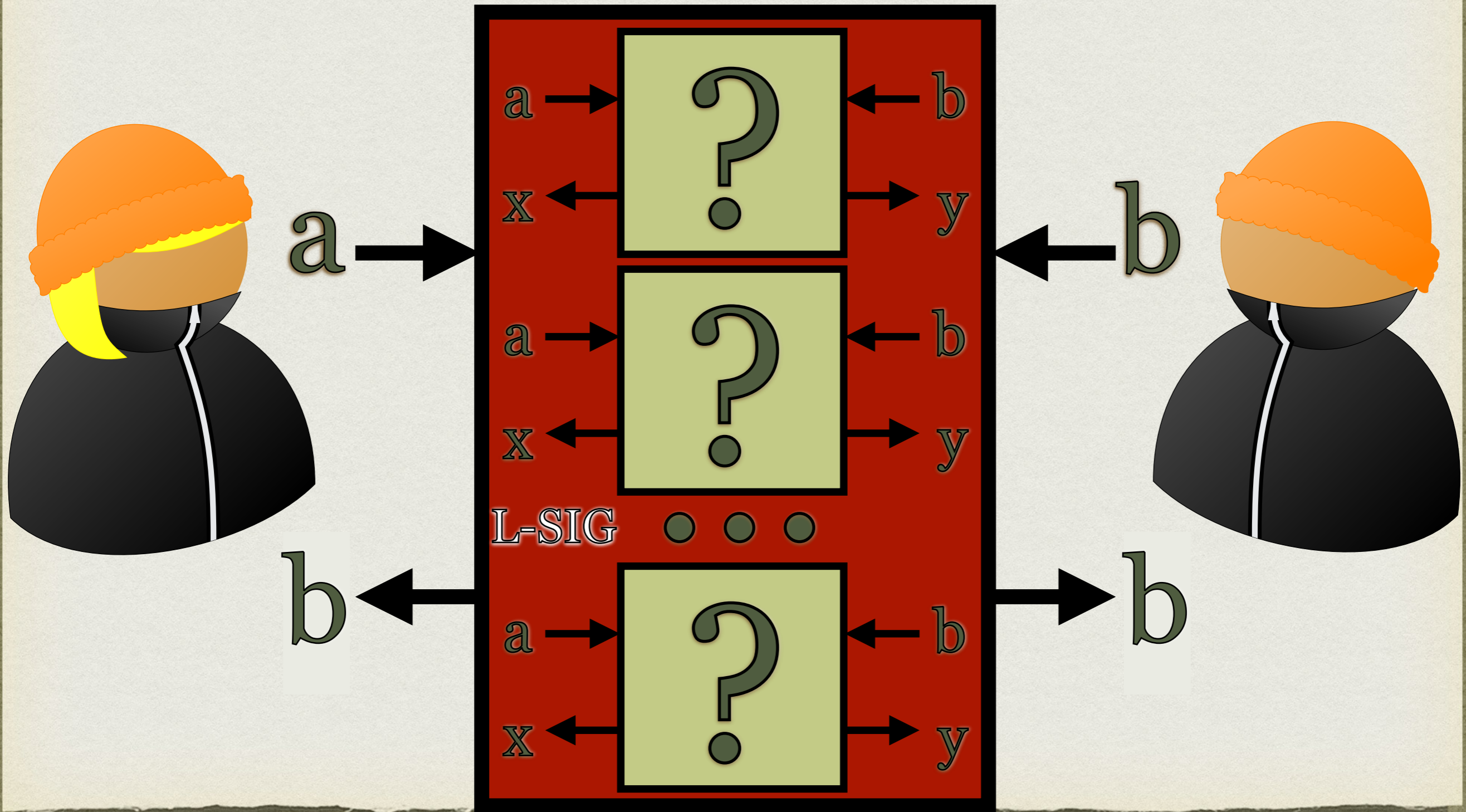

WHAT CONSTITUTES A SIGNALLING CHANNEL?



or



WHAT CONSTITUTES A SIGNALLING CHANNEL?

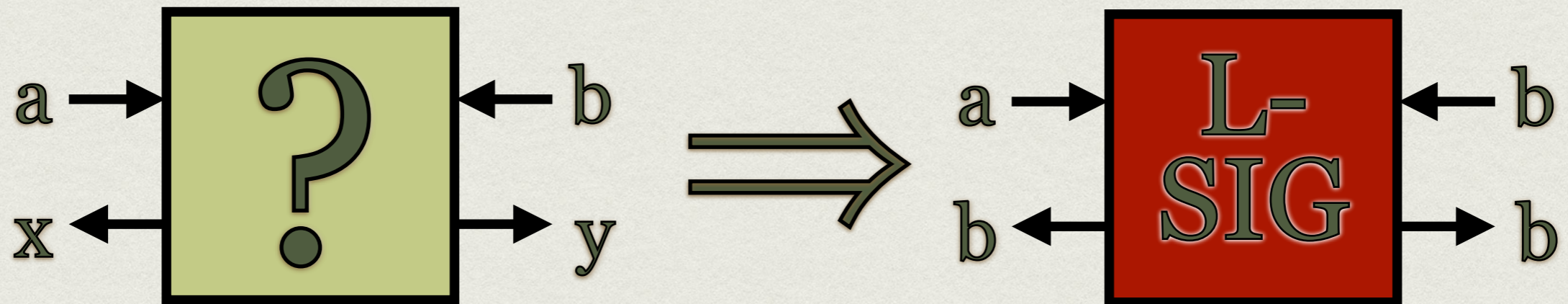

WHAT CONSTITUTES A SIGNALLING CHANNEL?

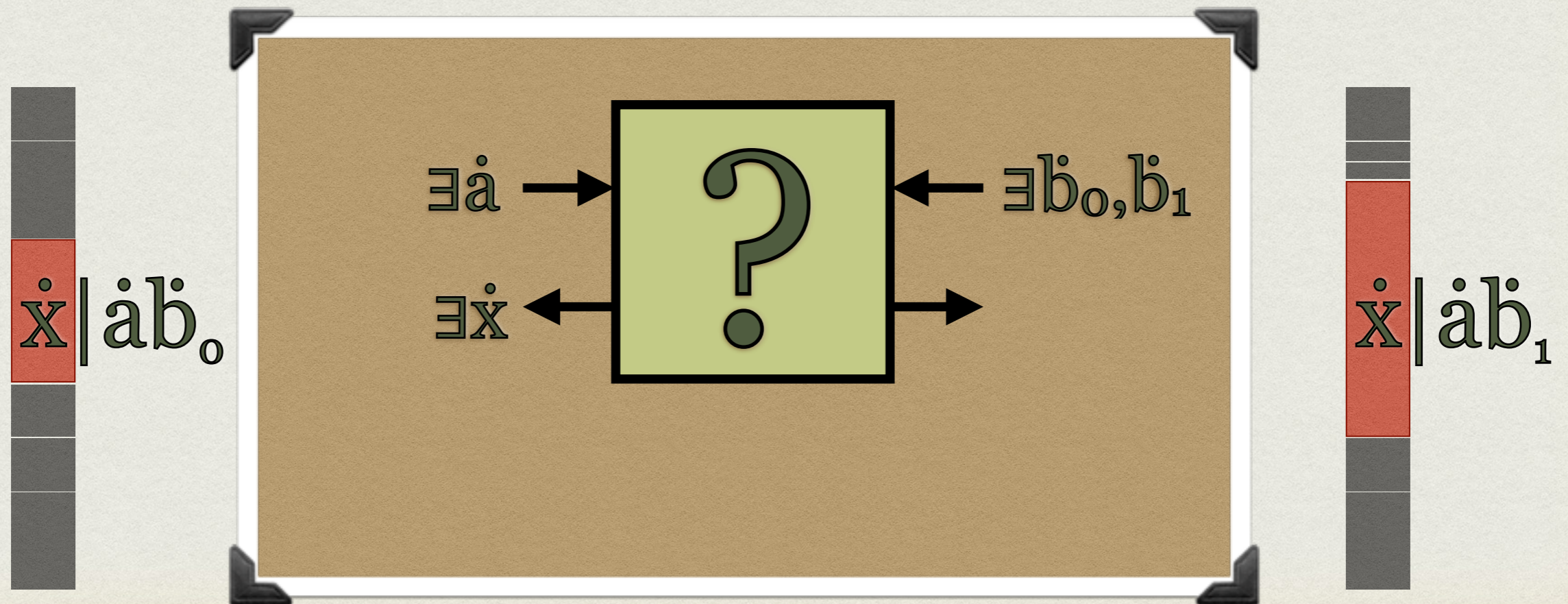
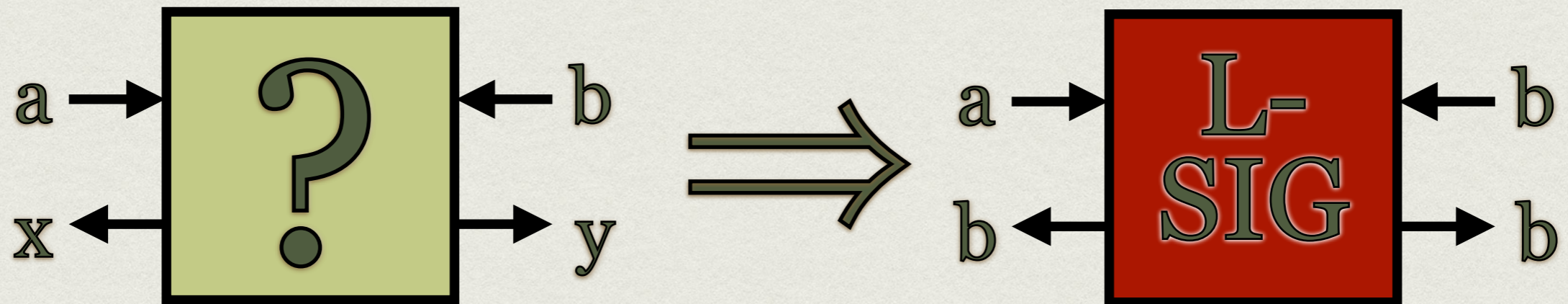

WHAT CONSTITUTES A SIGNALLING CHANNEL?

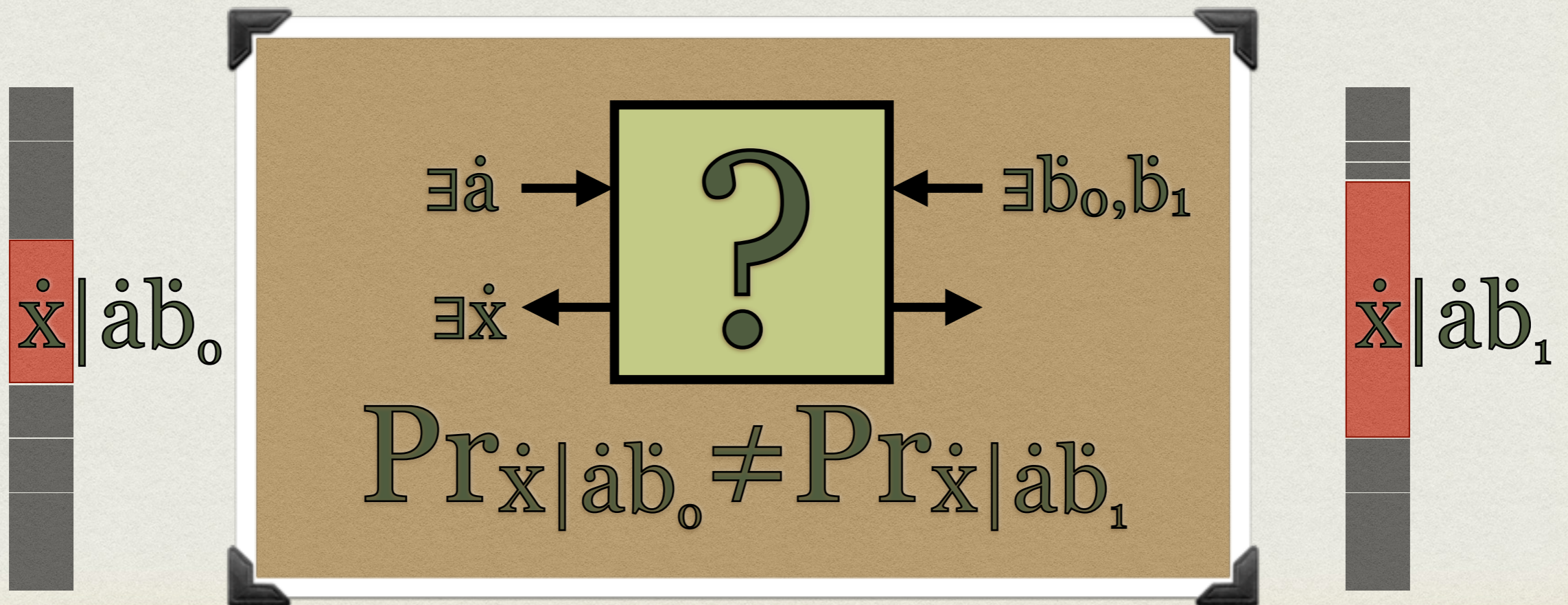
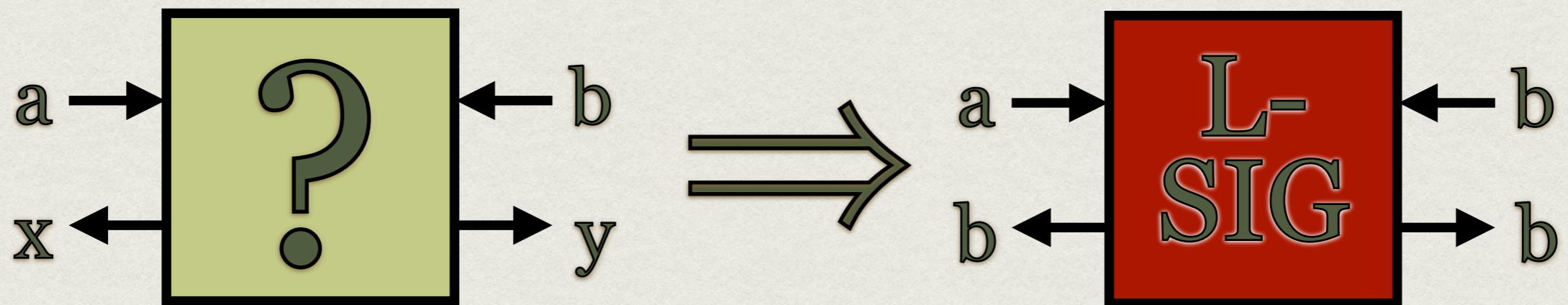

$$\exists a \exists b_0, b_1 \exists x \Pr_{x|ab_0} \neq \Pr_{x|ab_1}$$

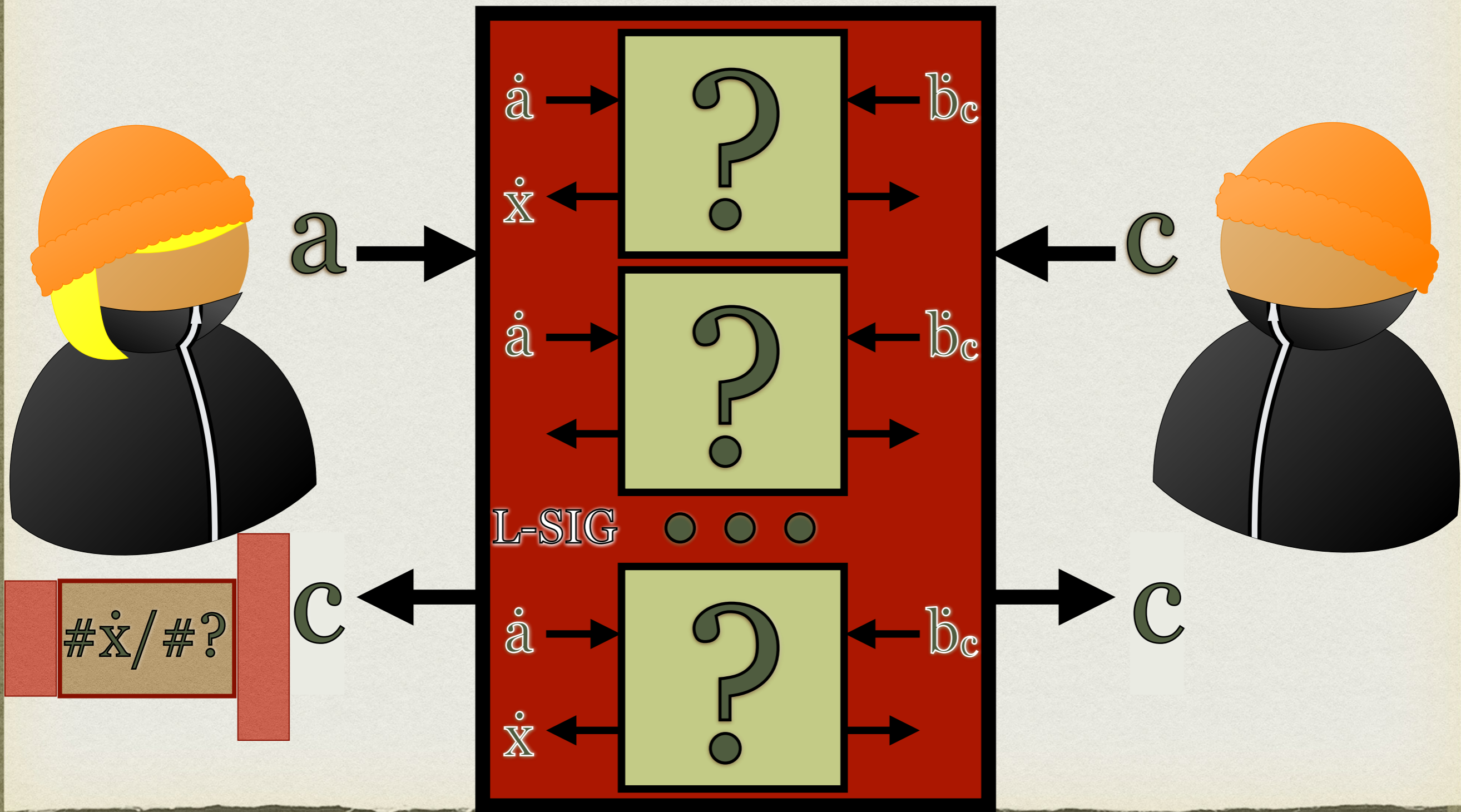

$$\exists \dot{a} \exists \dot{b}_0, \dot{b}_1 \exists \dot{x} \Pr_{\dot{x}|\dot{a}\dot{b}_0} \neq \Pr_{\dot{x}|\dot{a}\dot{b}_1}$$

$$\Pr_{\dot{x}|\dot{a}\dot{b}_c} \simeq \#\dot{x}/\#?$$

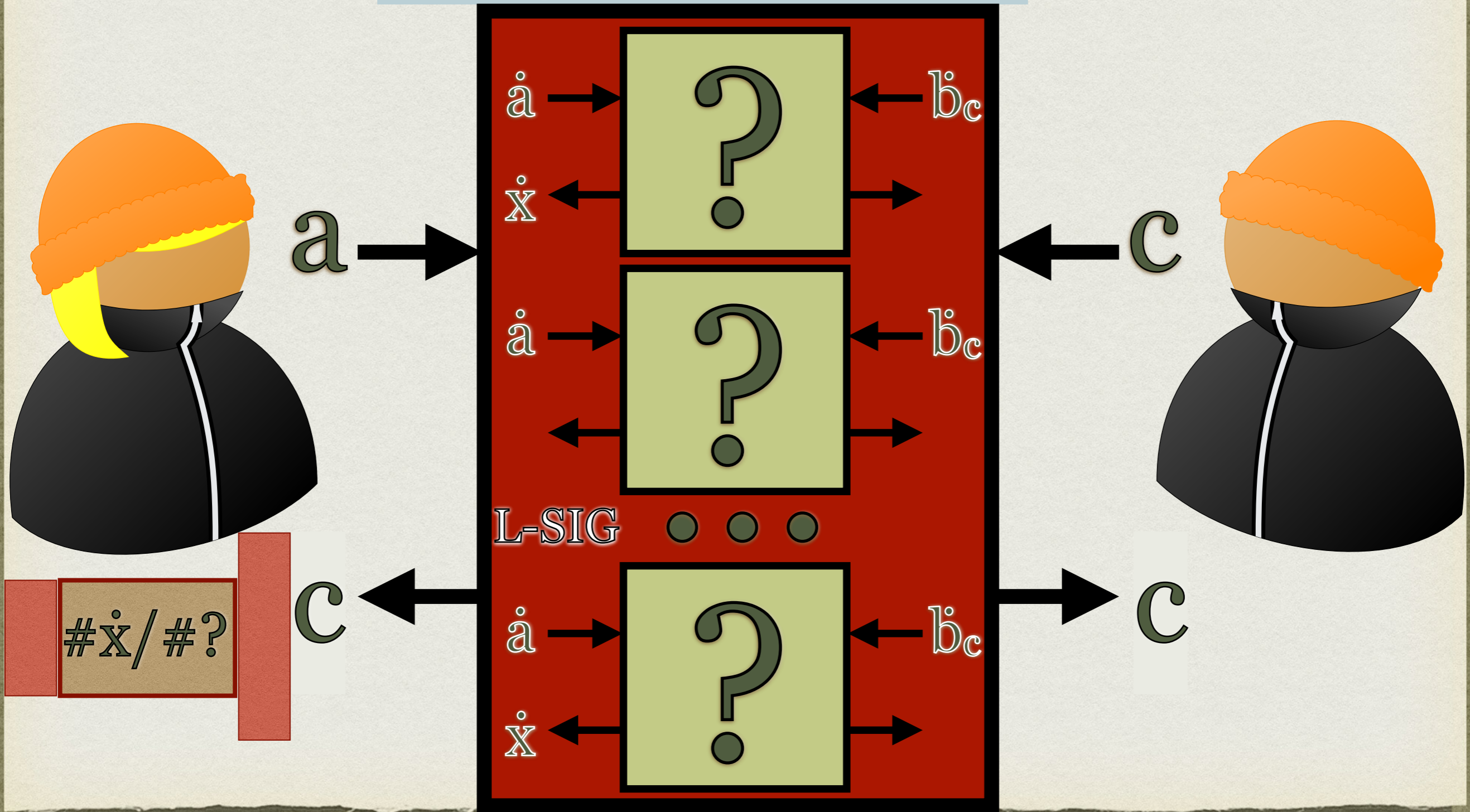

$c=0$: $Pr_{\dot{x}|ab_0} \approx \# \dot{x} / \# ? \neq Pr_{\dot{x}|ab_1}$

$Pr_{\dot{x}|ab_c} \approx \# \dot{x} / \# ?$

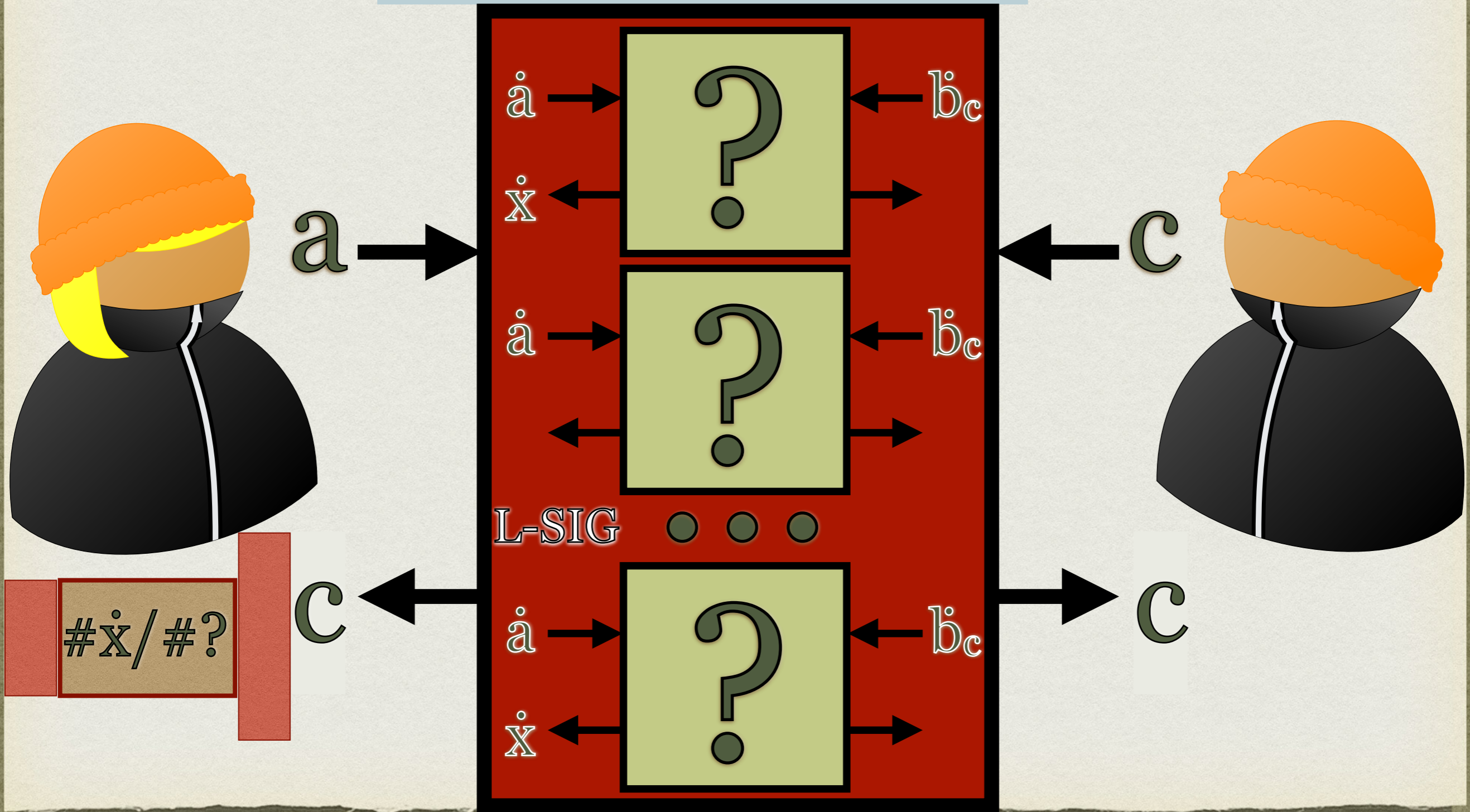

$c=0$: $\text{Pr}_{\dot{x}|ab_0} \simeq \# \dot{x} / \# ? \neq \text{Pr}_{\dot{x}|ab_1}$

$c=1$: $\text{Pr}_{\dot{x}|ab_0} \neq \# \dot{x} / \# ? \simeq \text{Pr}_{\dot{x}|ab_1}$

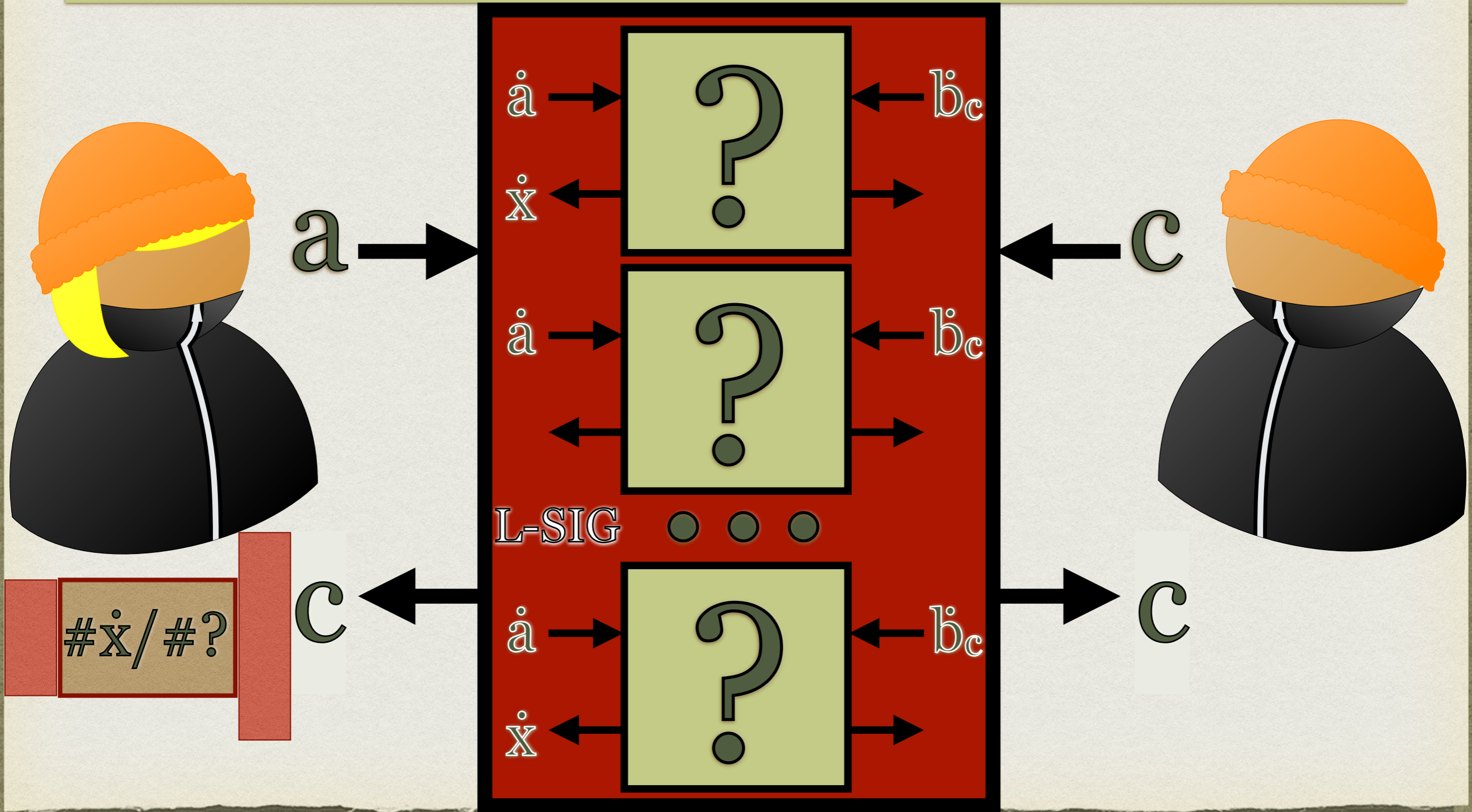

GENERAL SIGNALLING

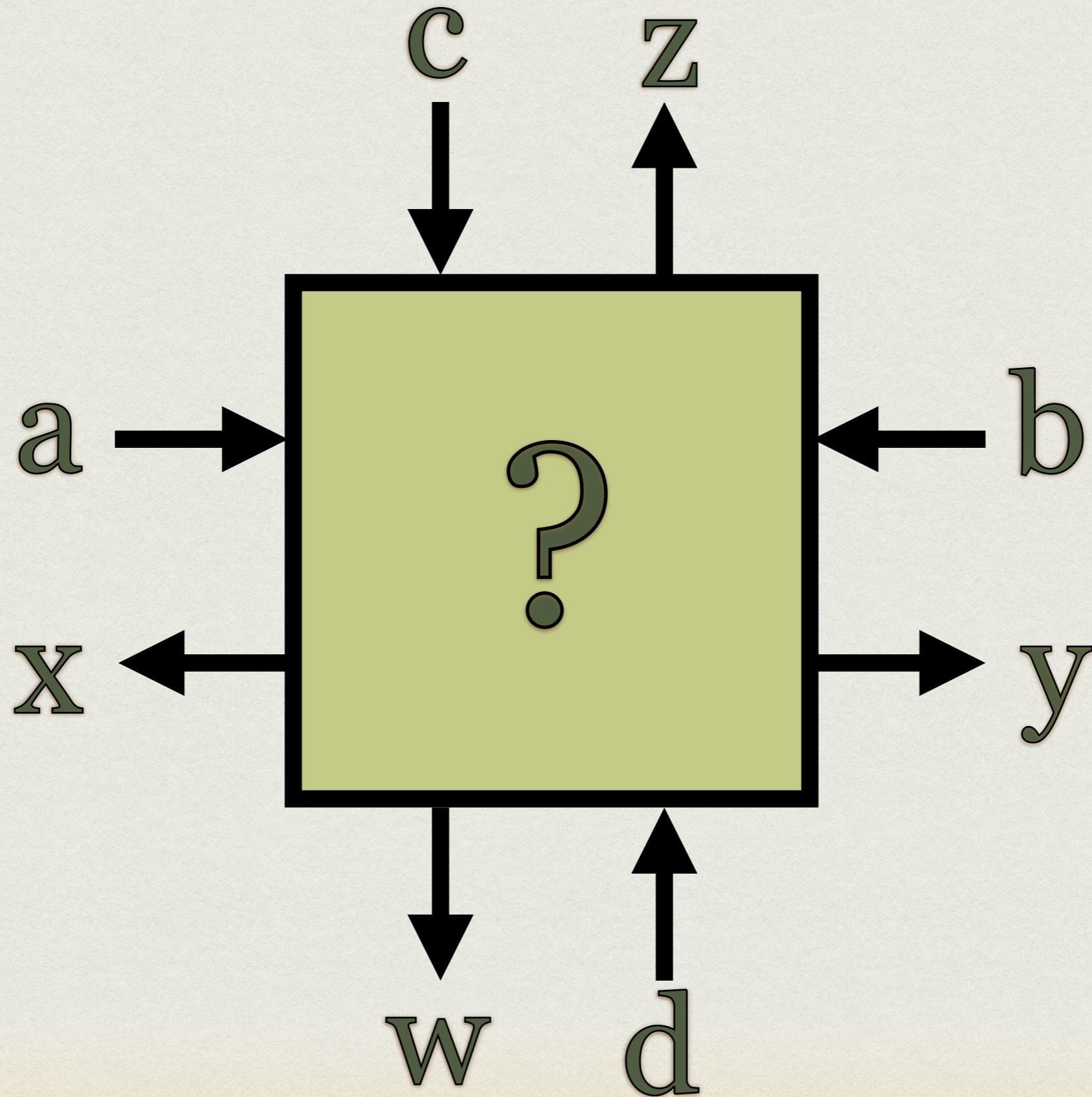

GENERAL SIGNALLING

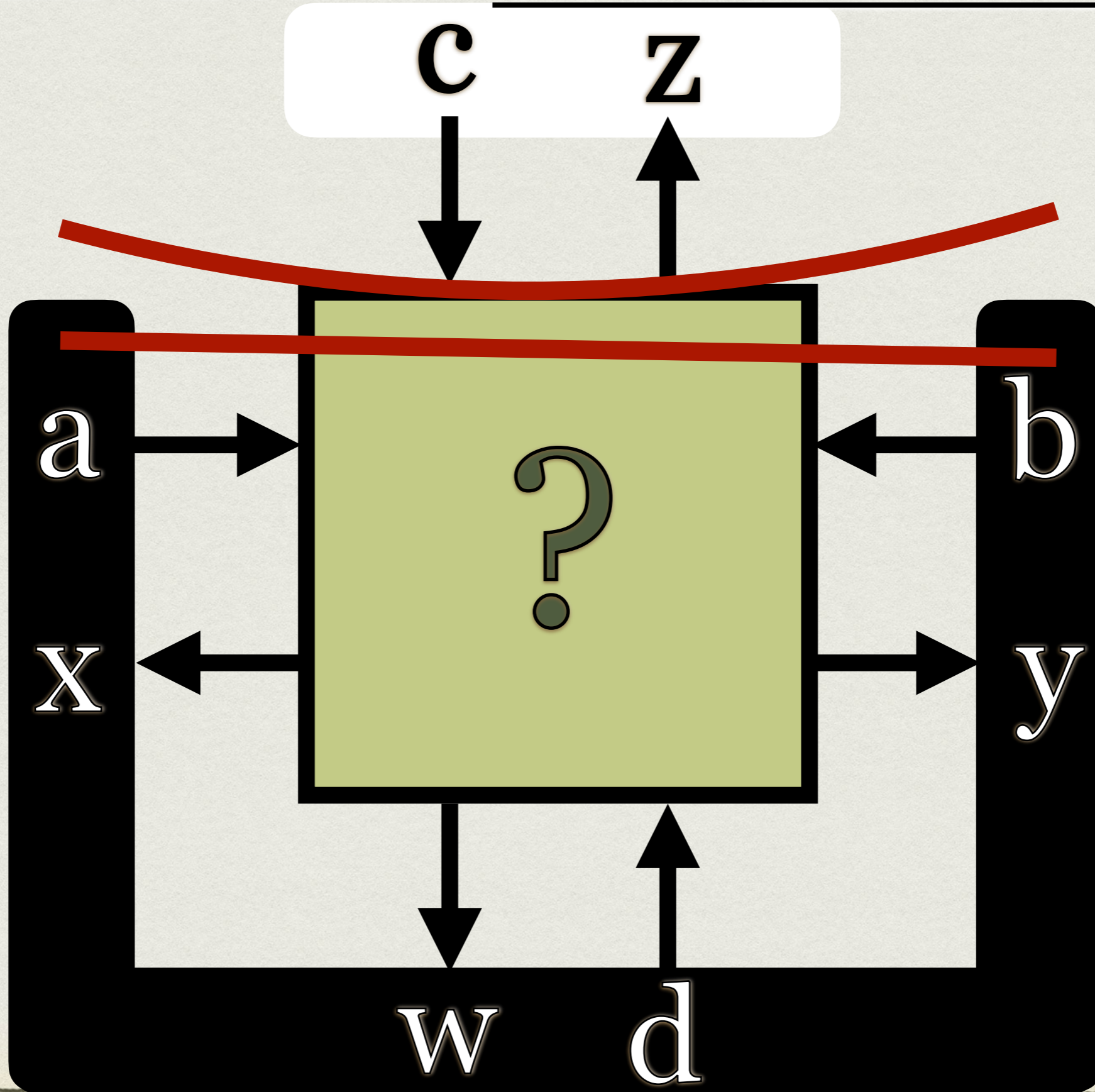

GENERAL SIGNALLING

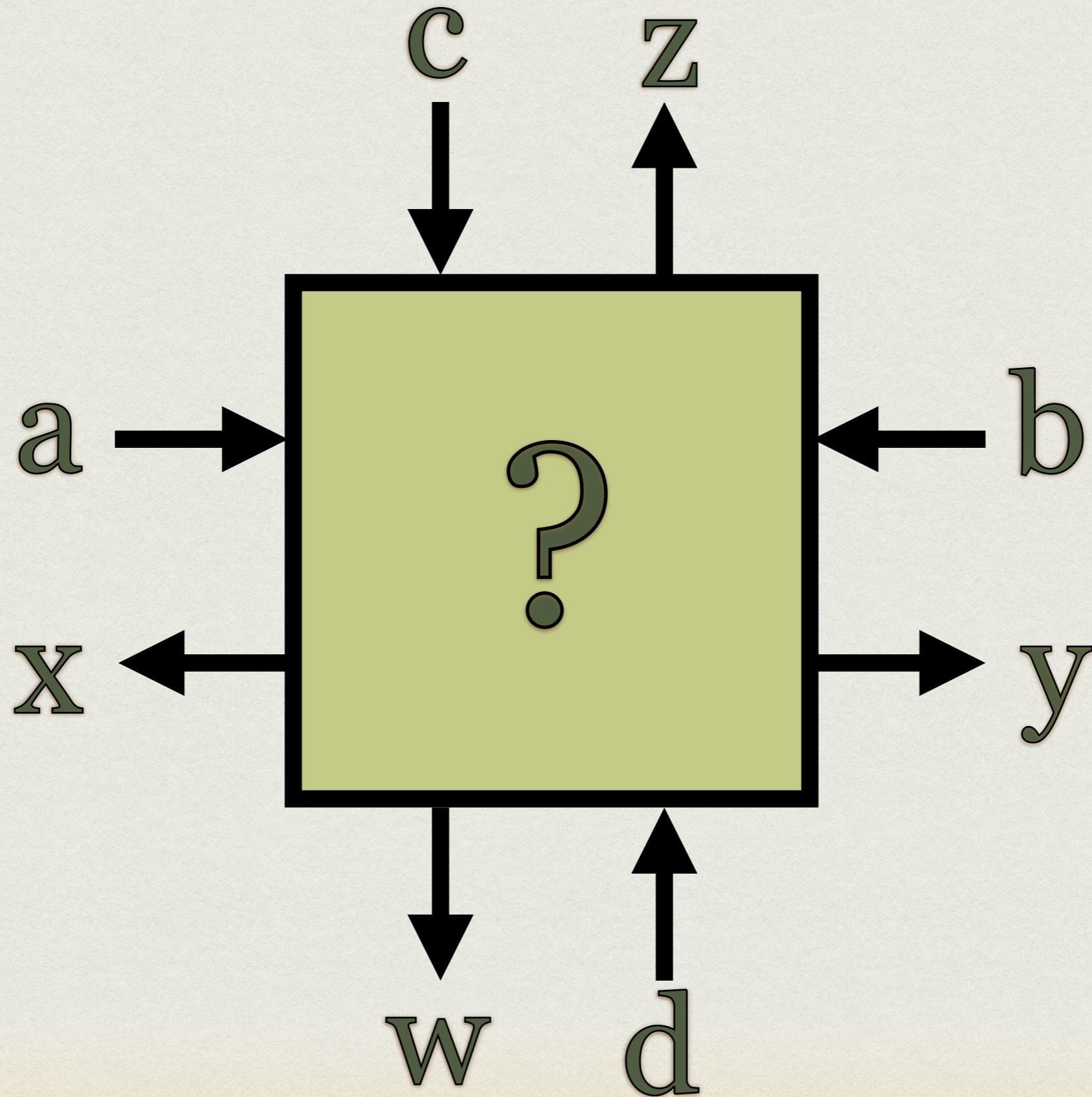

GENERAL SIGNALLING

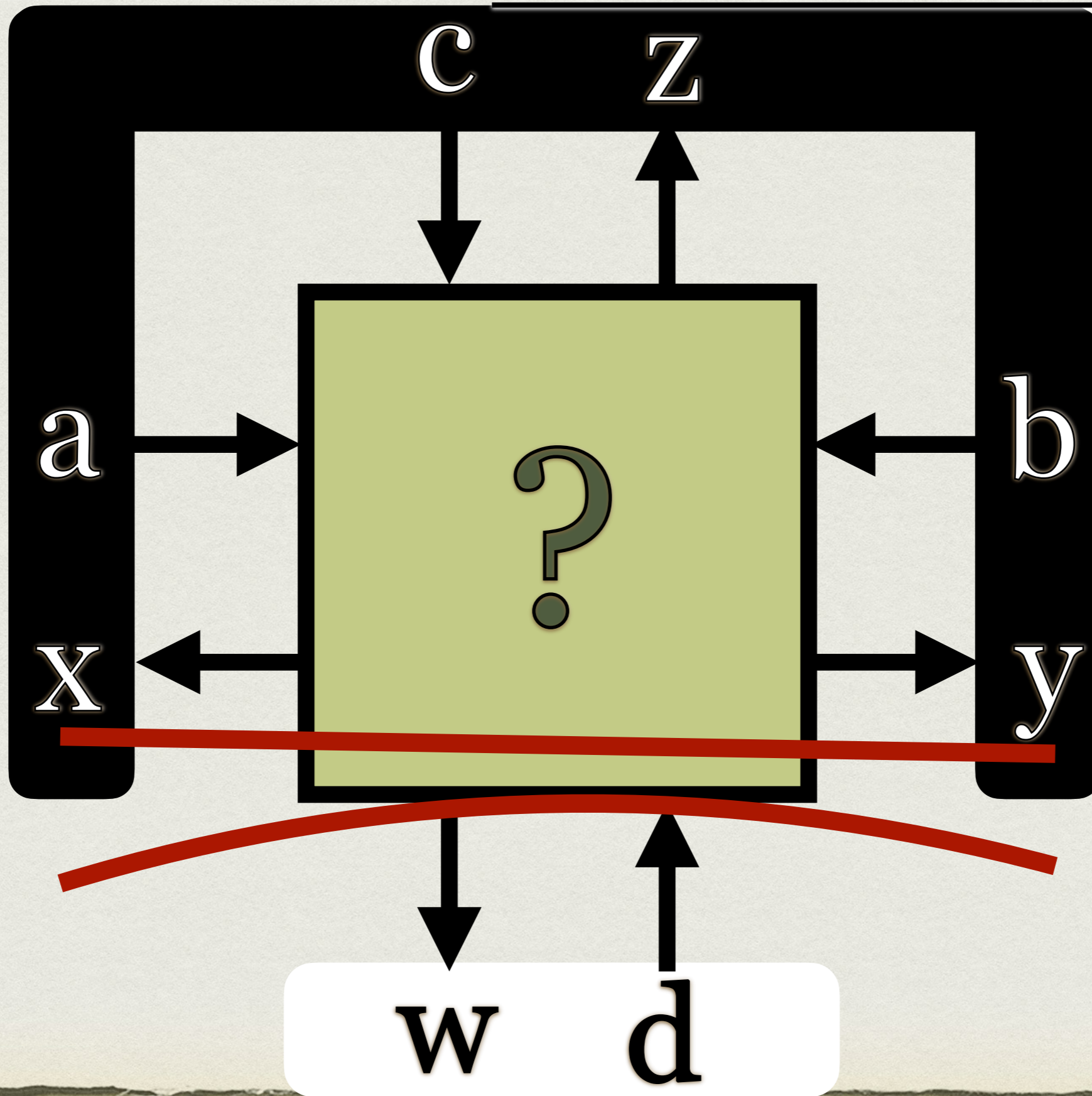

GENERAL SIGNALLING

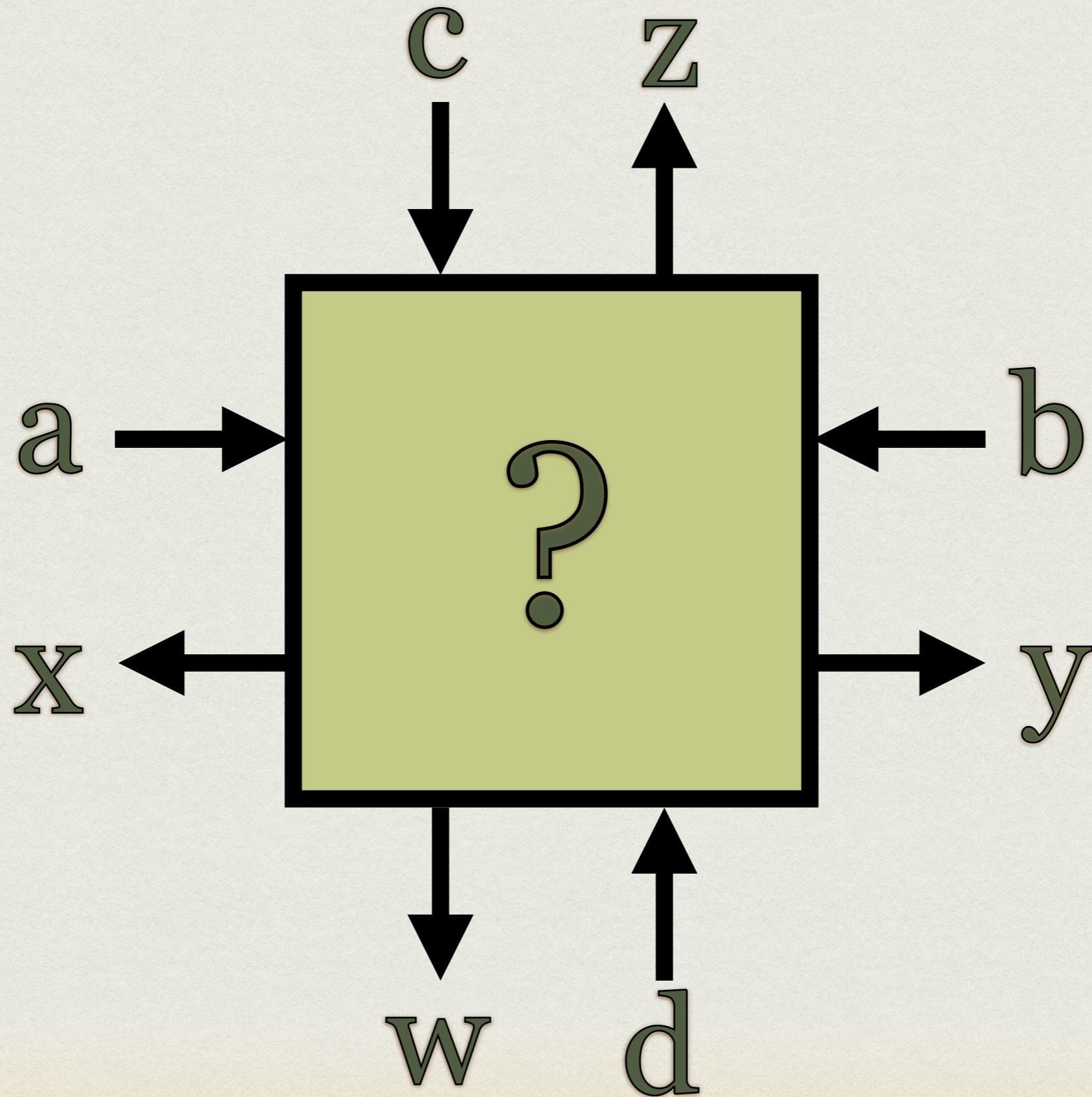

GENERAL SIGNALLING

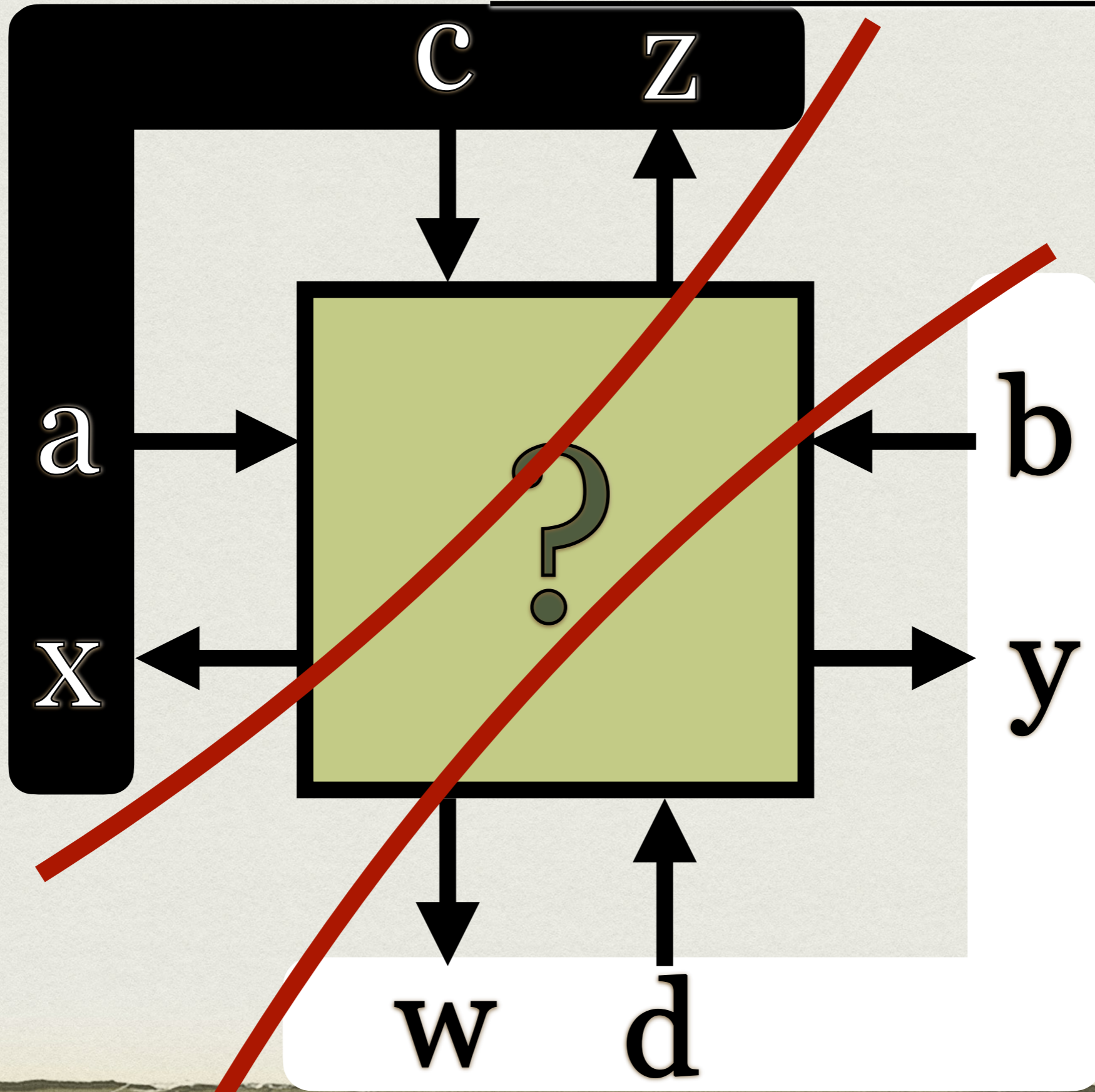

WHAT CONSTITUTES A SIGNALLING CHANNEL?

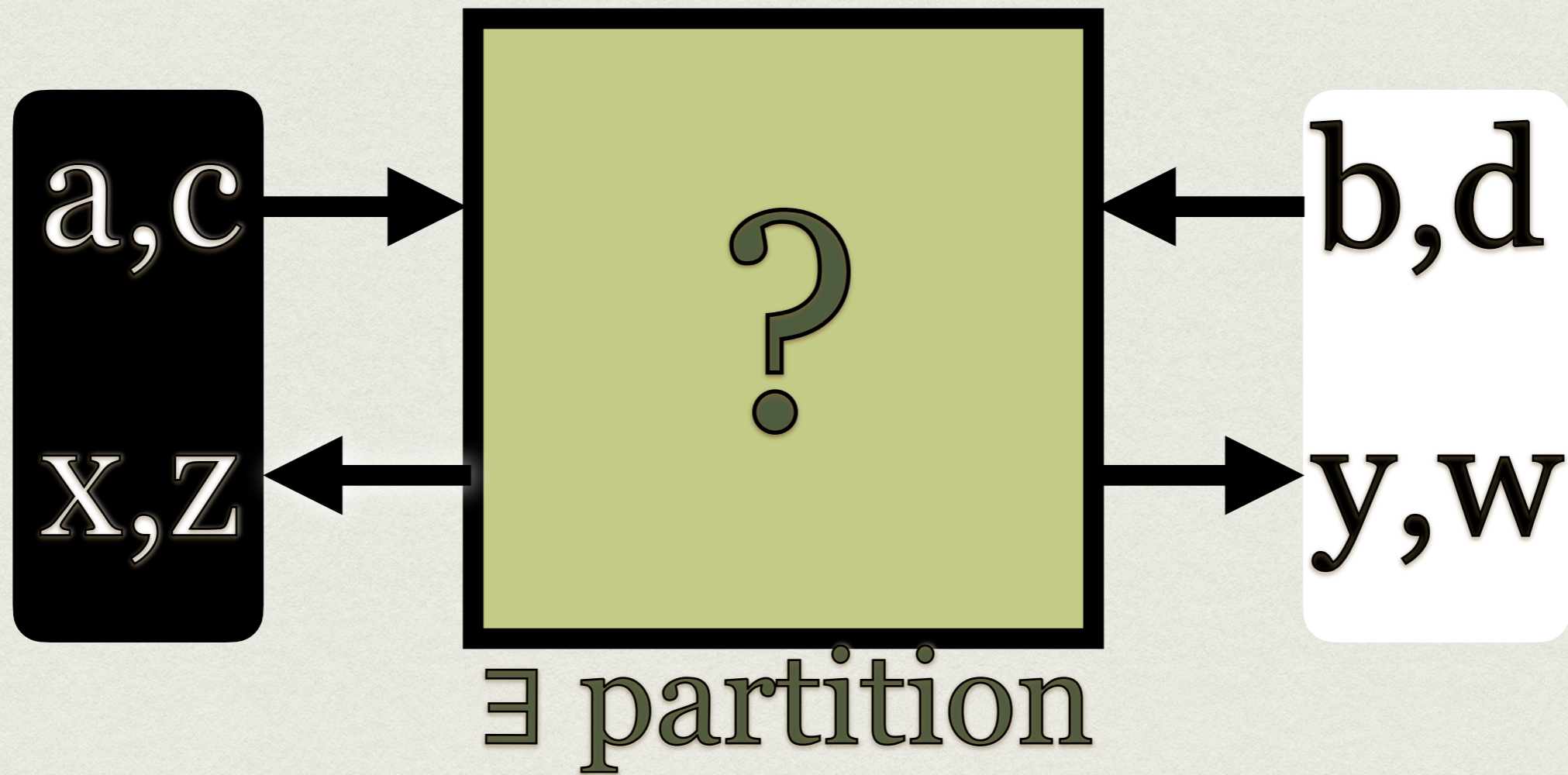

WHAT CONSTITUTES A SIGNALLING CHANNEL?

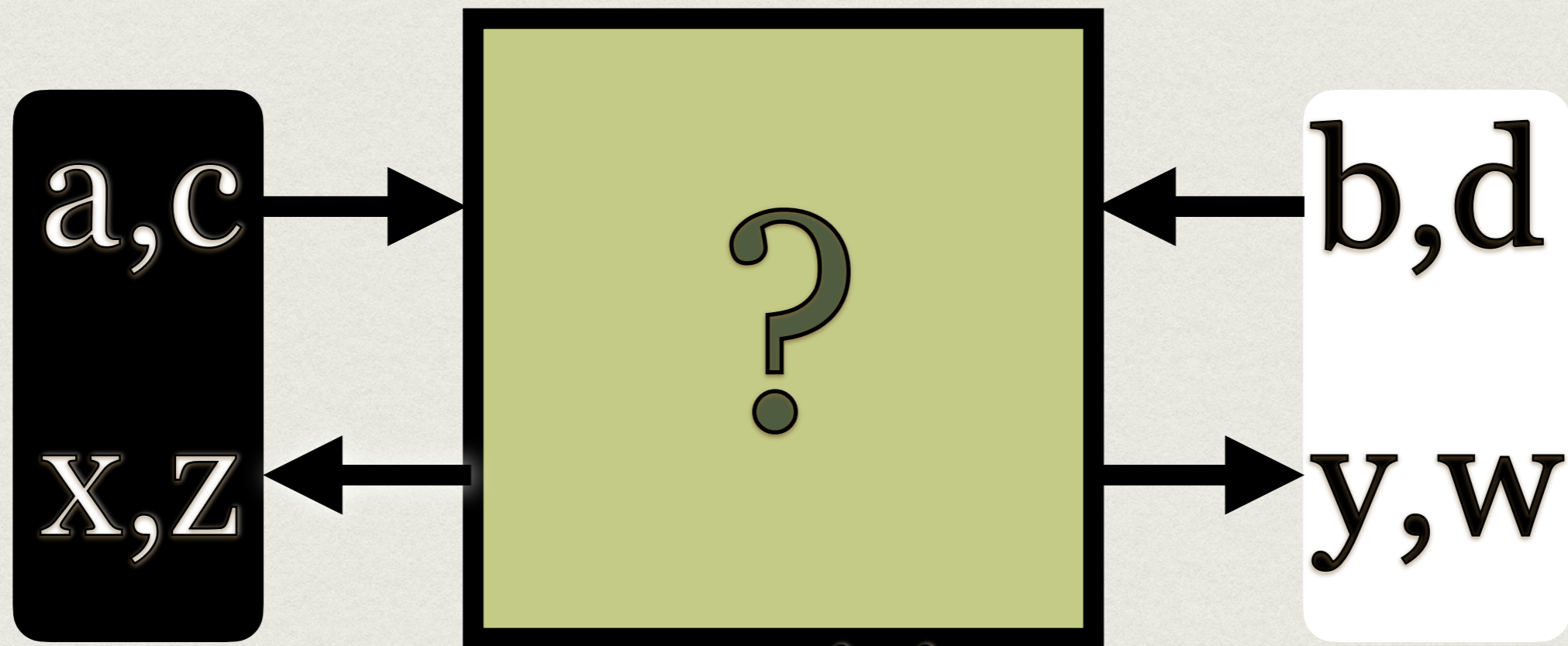

\exists partition



or



WHAT CONSTITUTES A NO-SIGNALLING CHANNEL?



WHAT CONSTITUTES A NO-SIGNALLING CHANNEL?

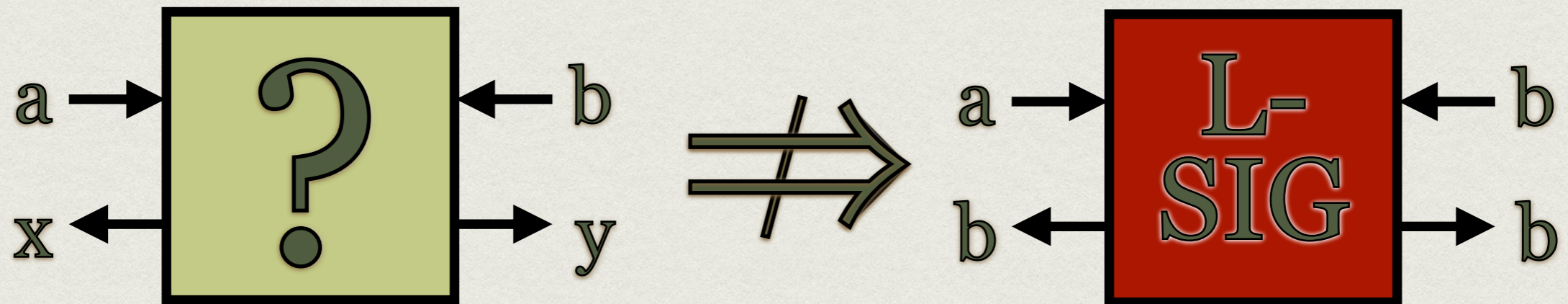

WHAT CONSTITUTES A NO-SIGNALLING CHANNEL?

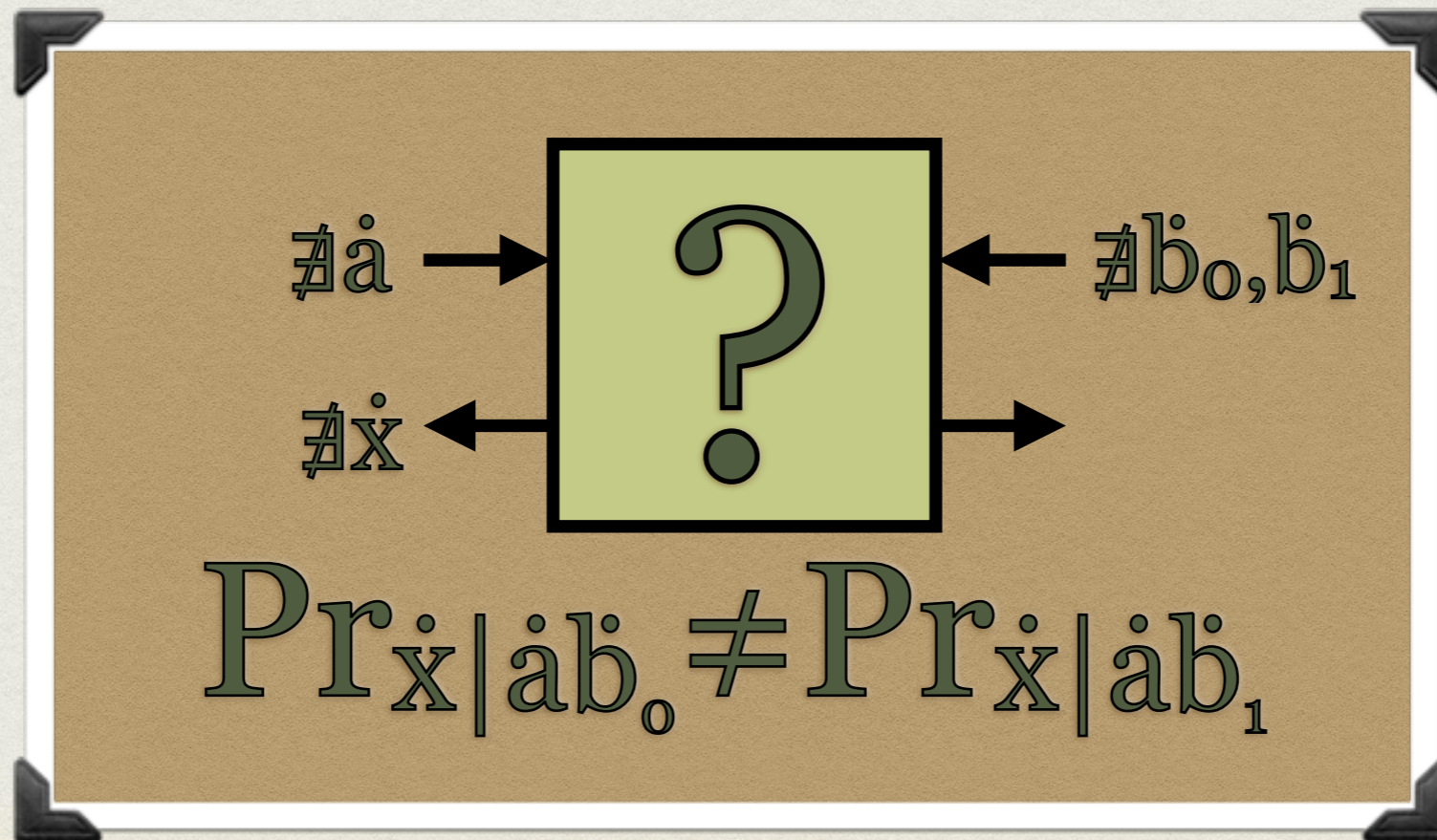
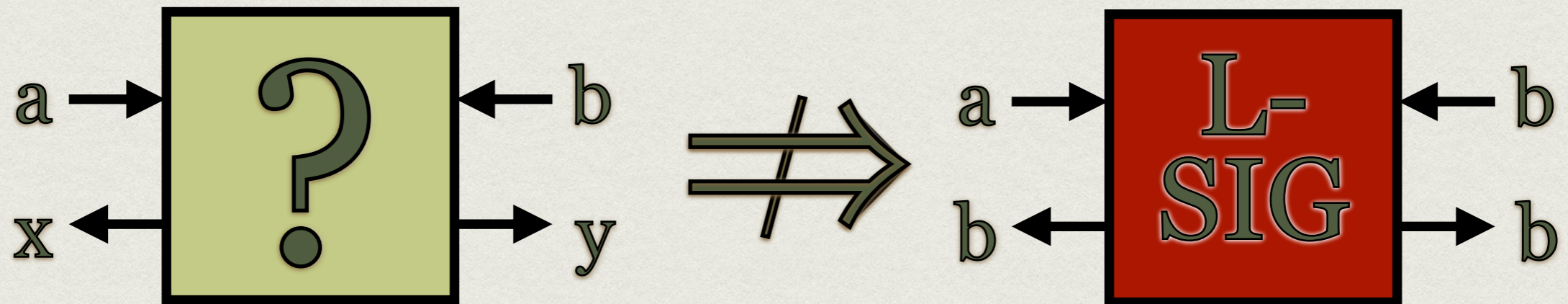

WHAT CONSTITUTES A NO-SIGNALLING CHANNEL?

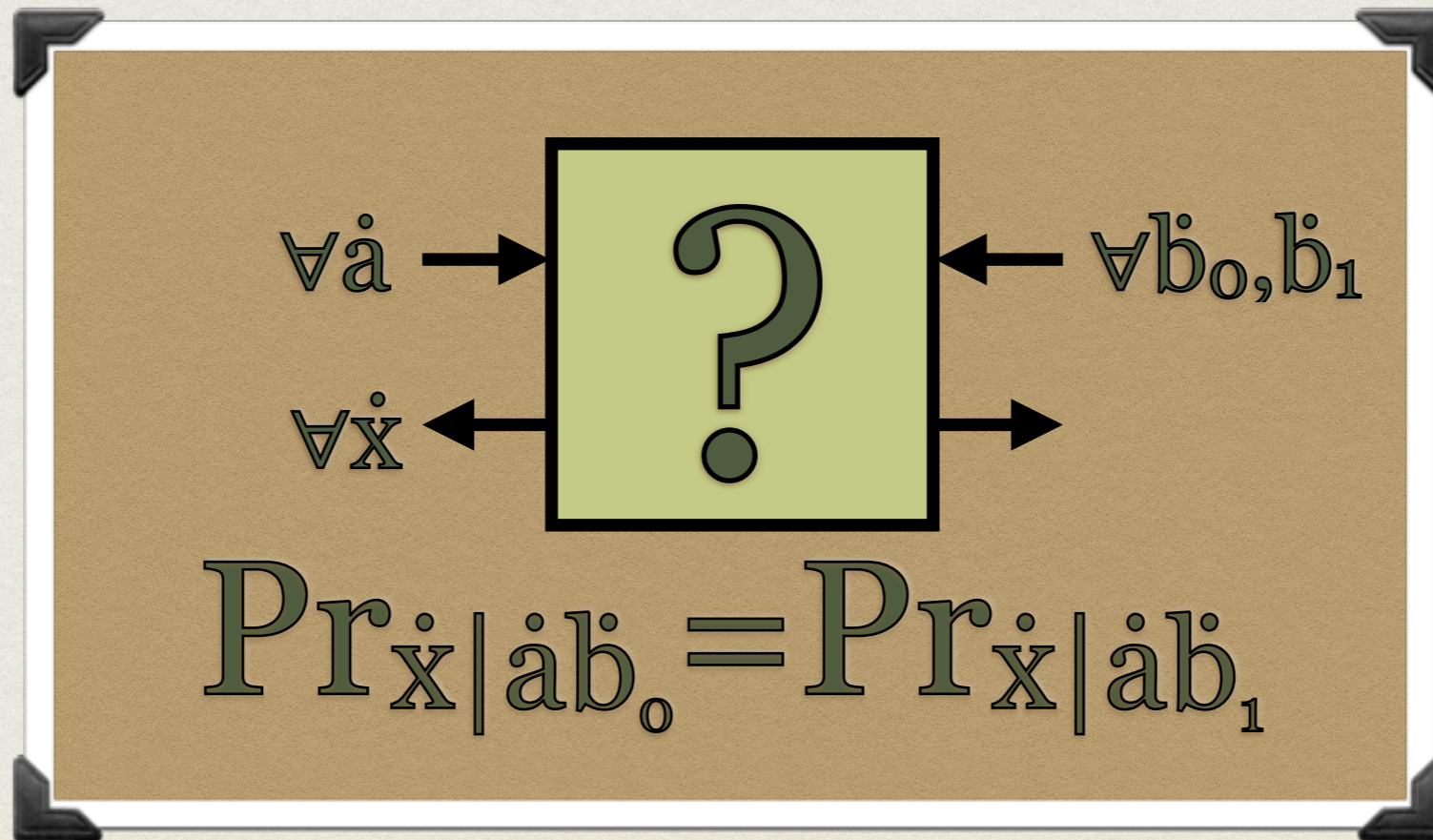
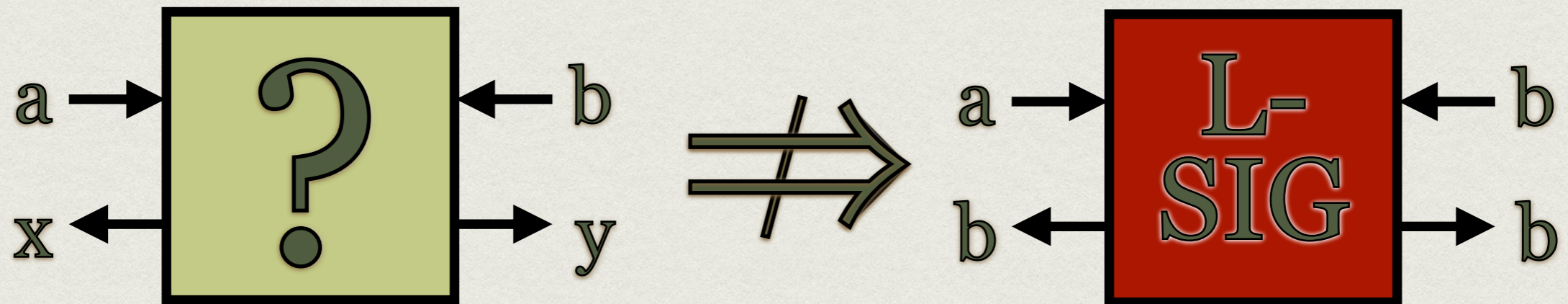

WHAT CONSTITUTES A NO-SIGNALLING CHANNEL?

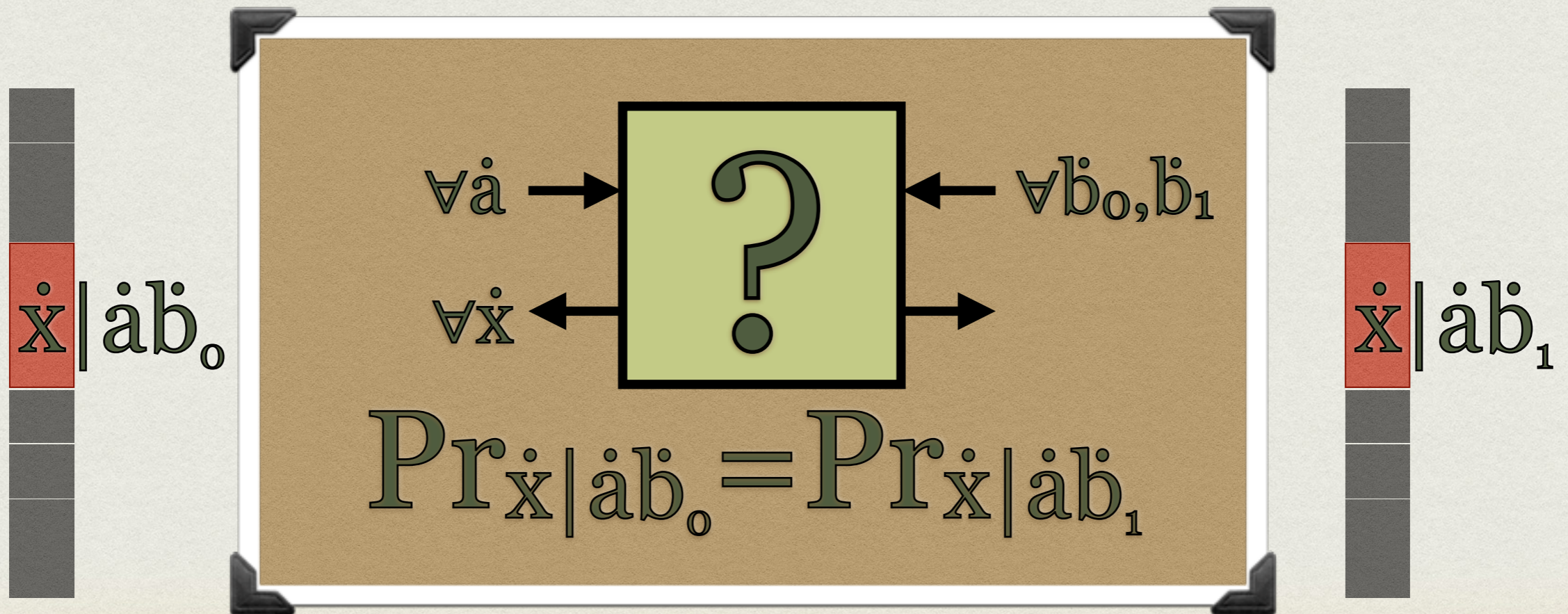
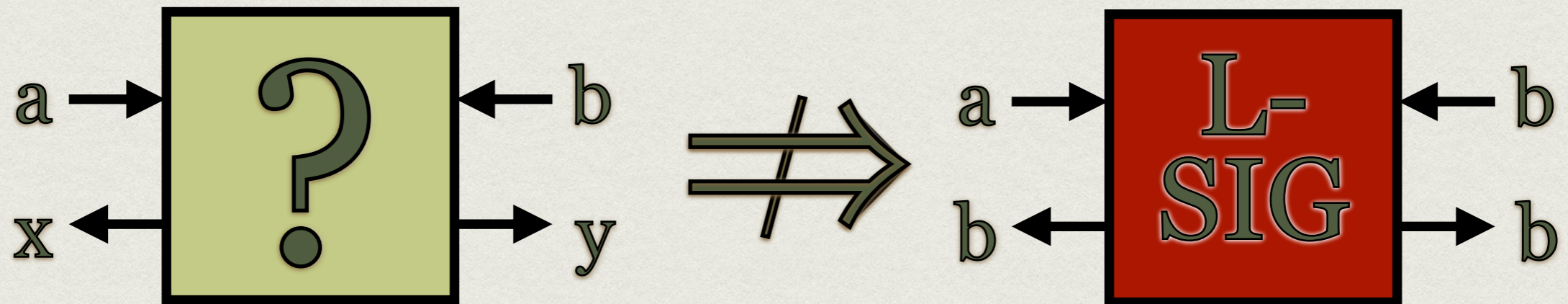

WHAT CONSTITUTES A NO-SIGNALLING CHANNEL?

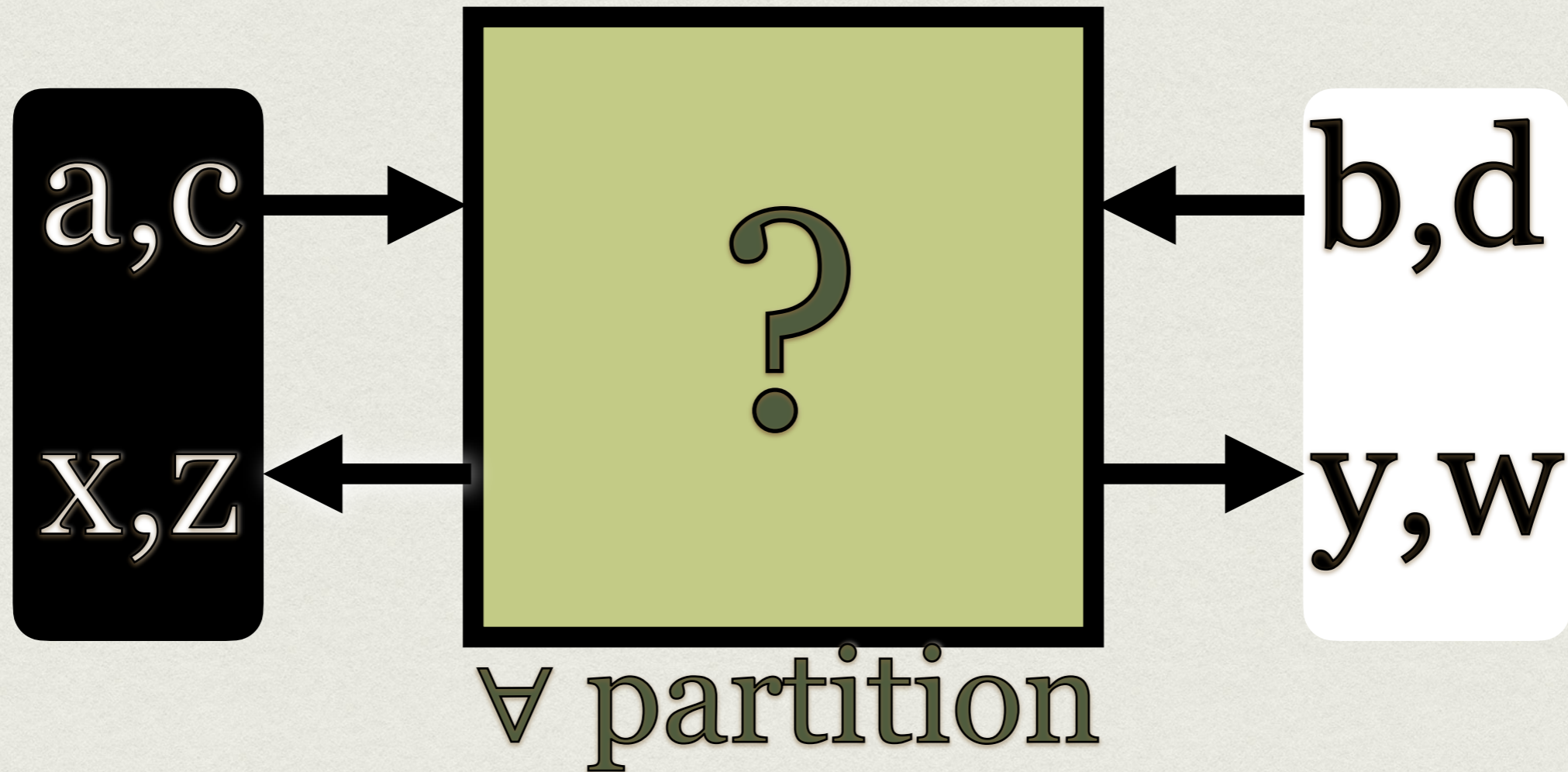

WHAT CONSTITUTES A NO-SIGNALLING CHANNEL?

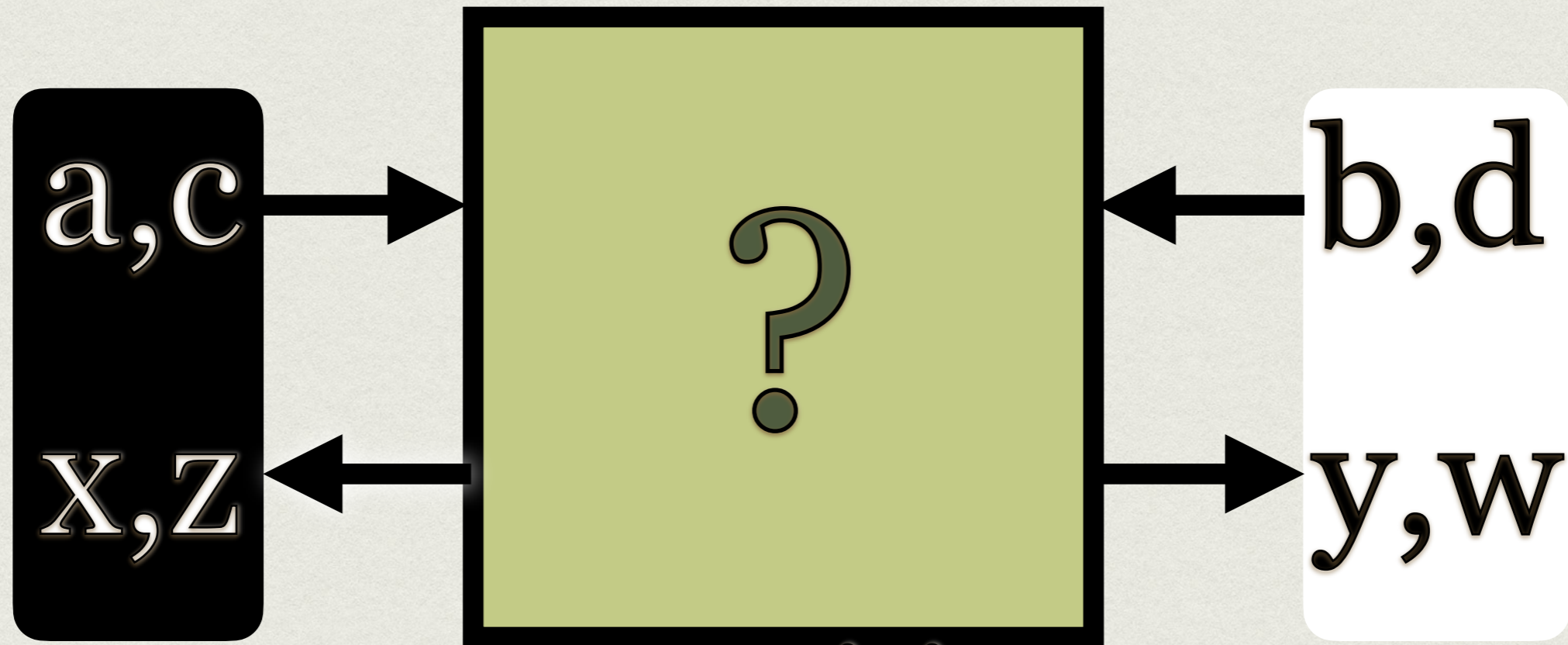

\forall partition

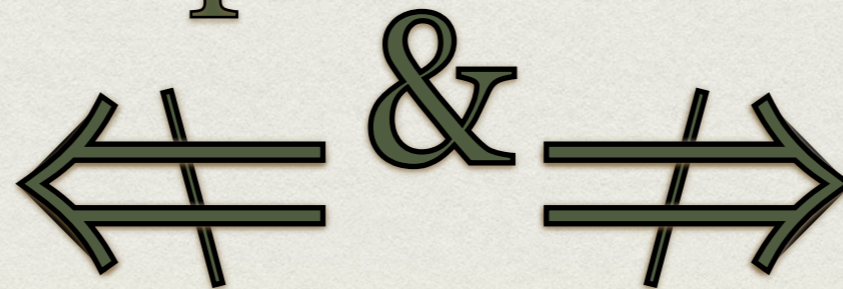

NO-SIGNALLING CHANNELS

$$A=B=X=Y=\{\text{red}, \text{green}, \text{blue}\}$$

$$a \neq x \neq y \neq b$$

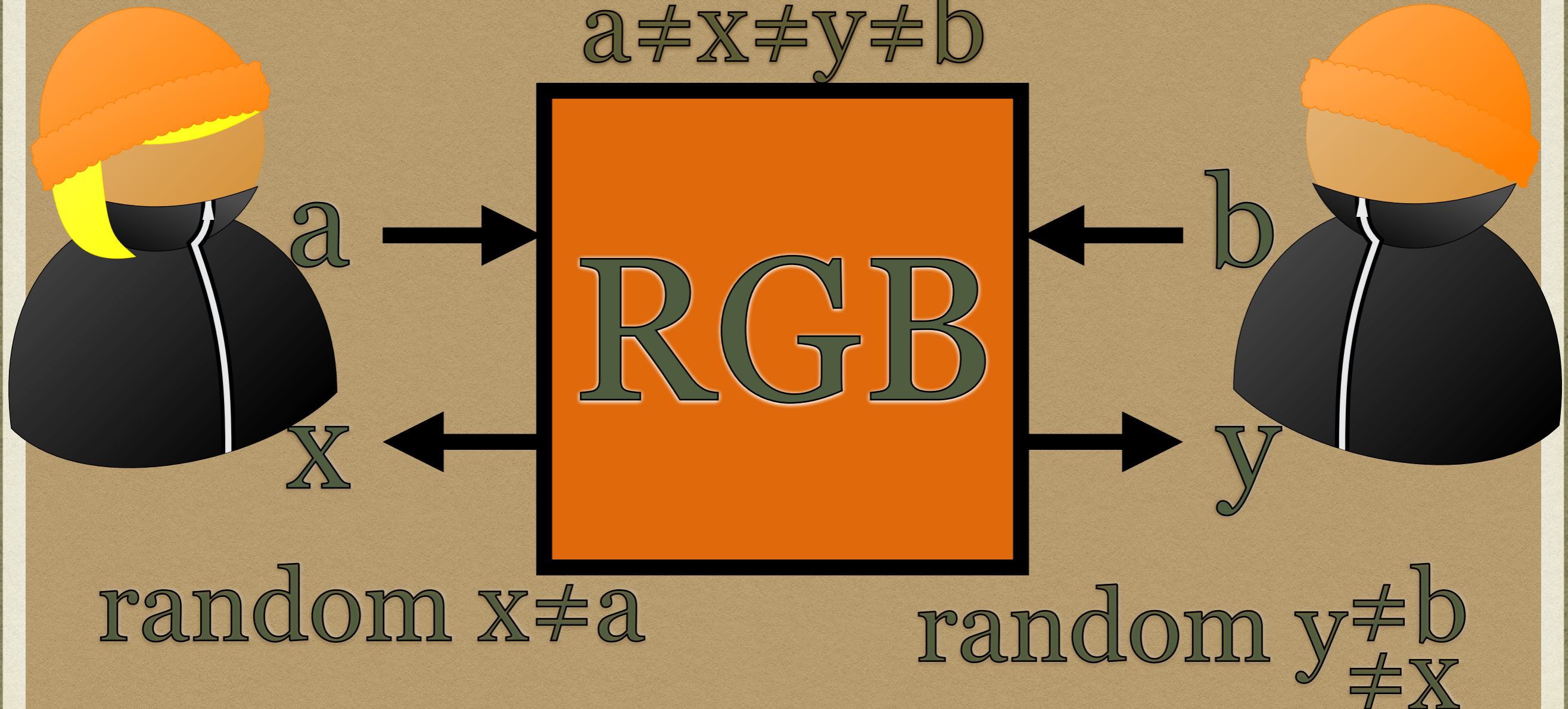

NO-SIGNALLING CHANNELS

$$A=B=X=Y=\{\text{red}, \text{green}, \text{blue}\}$$

$$a \neq x \neq y \neq b$$

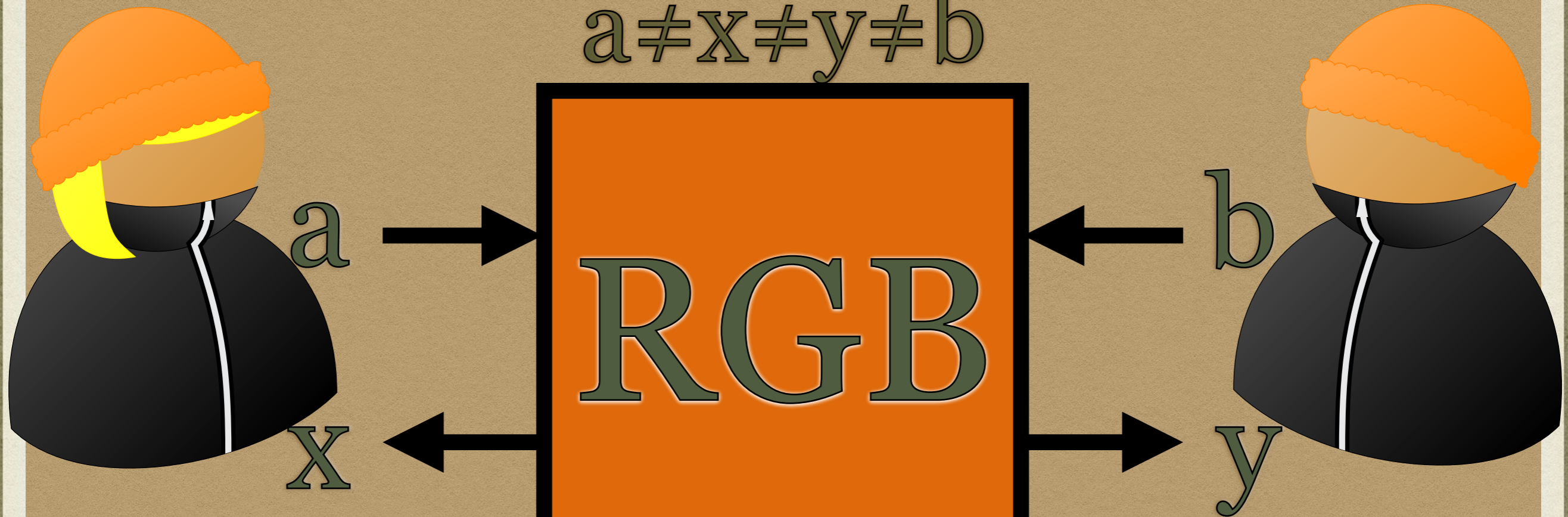

random $x \neq a$
 $\neq y$

random $y \neq b$

NON-LOCALITY
HIERARCHY

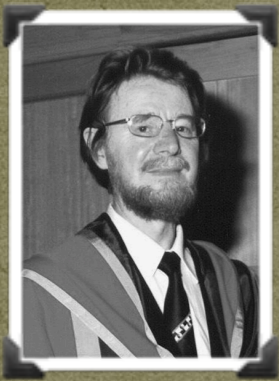

LOCALITY

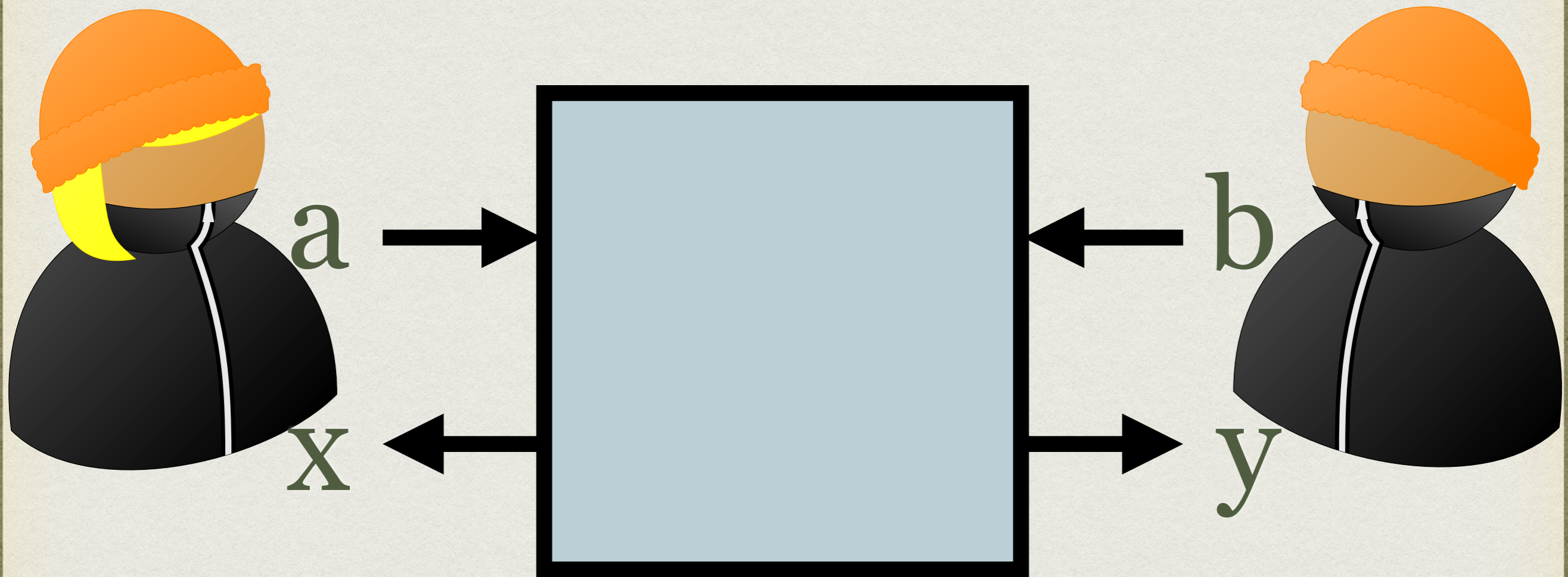

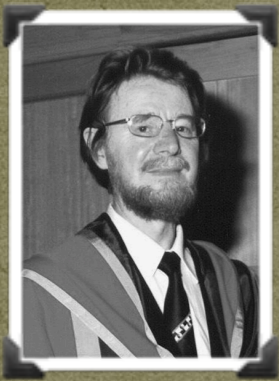

LOCALITY

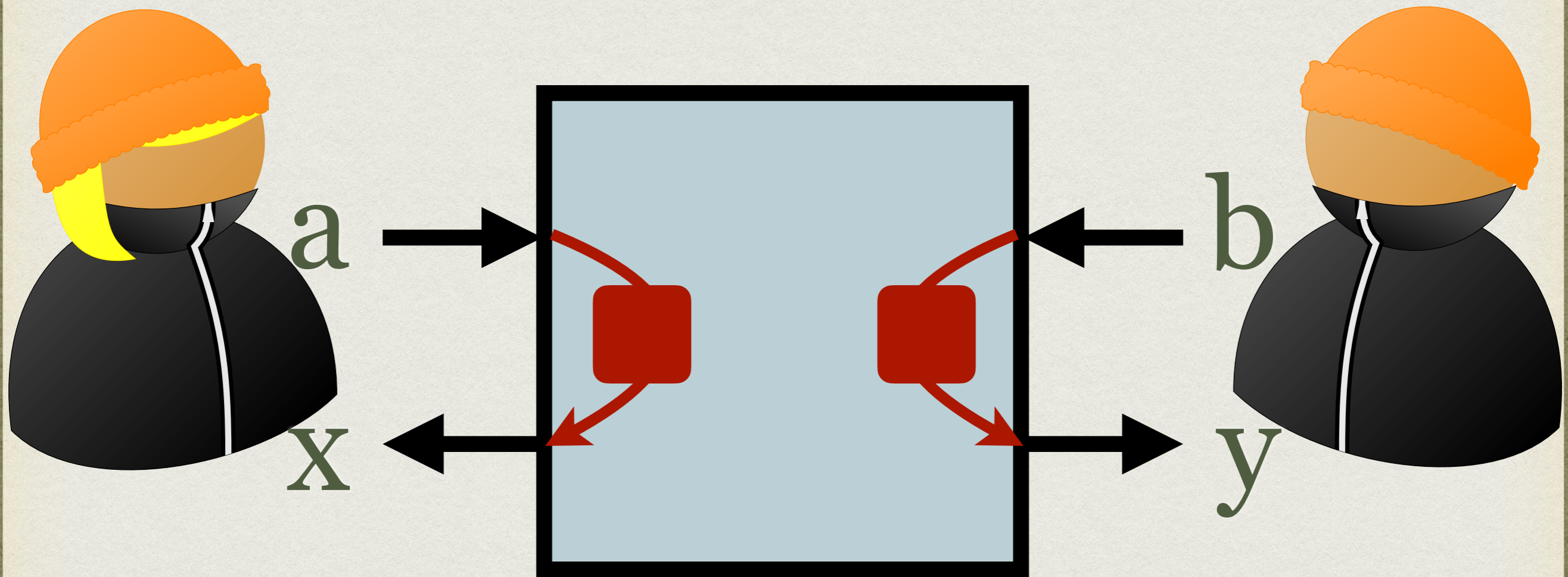

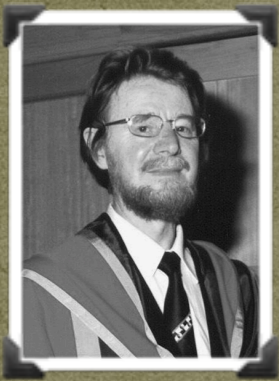

LOCALITY

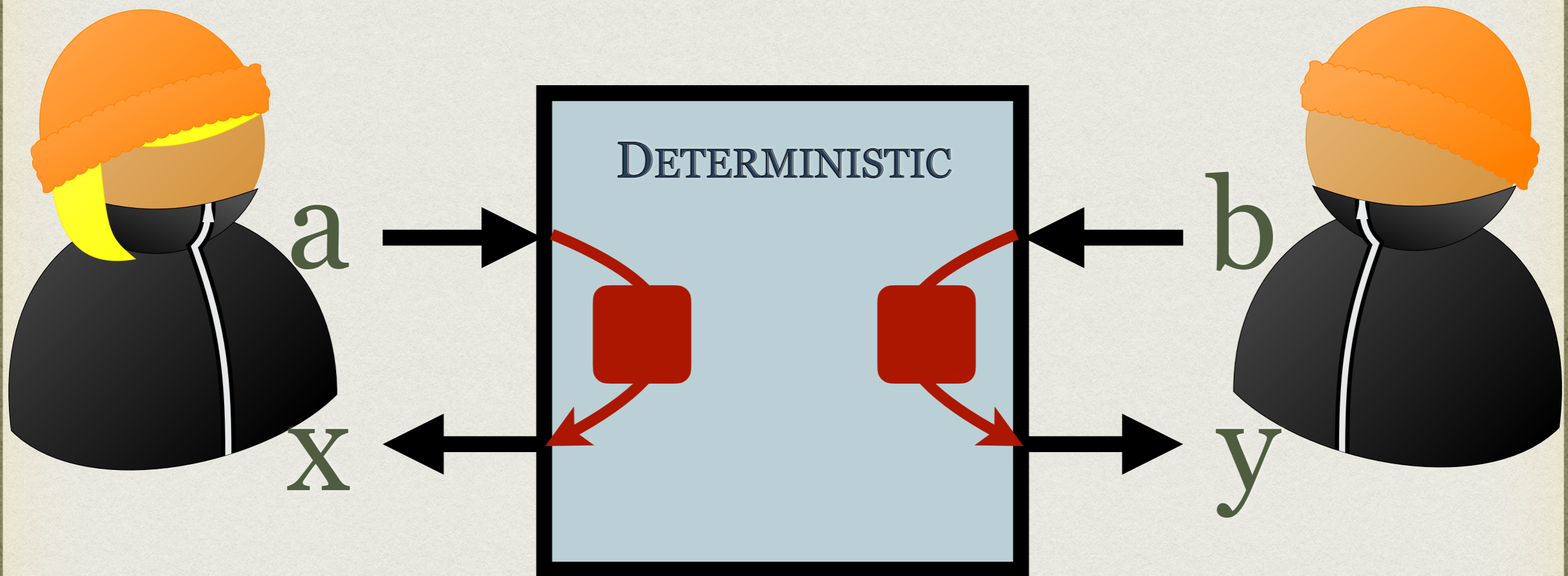

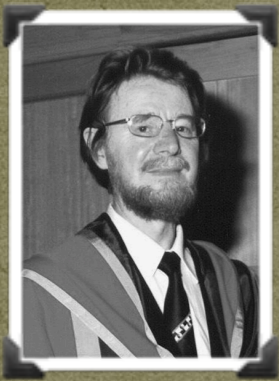

LOCALITY

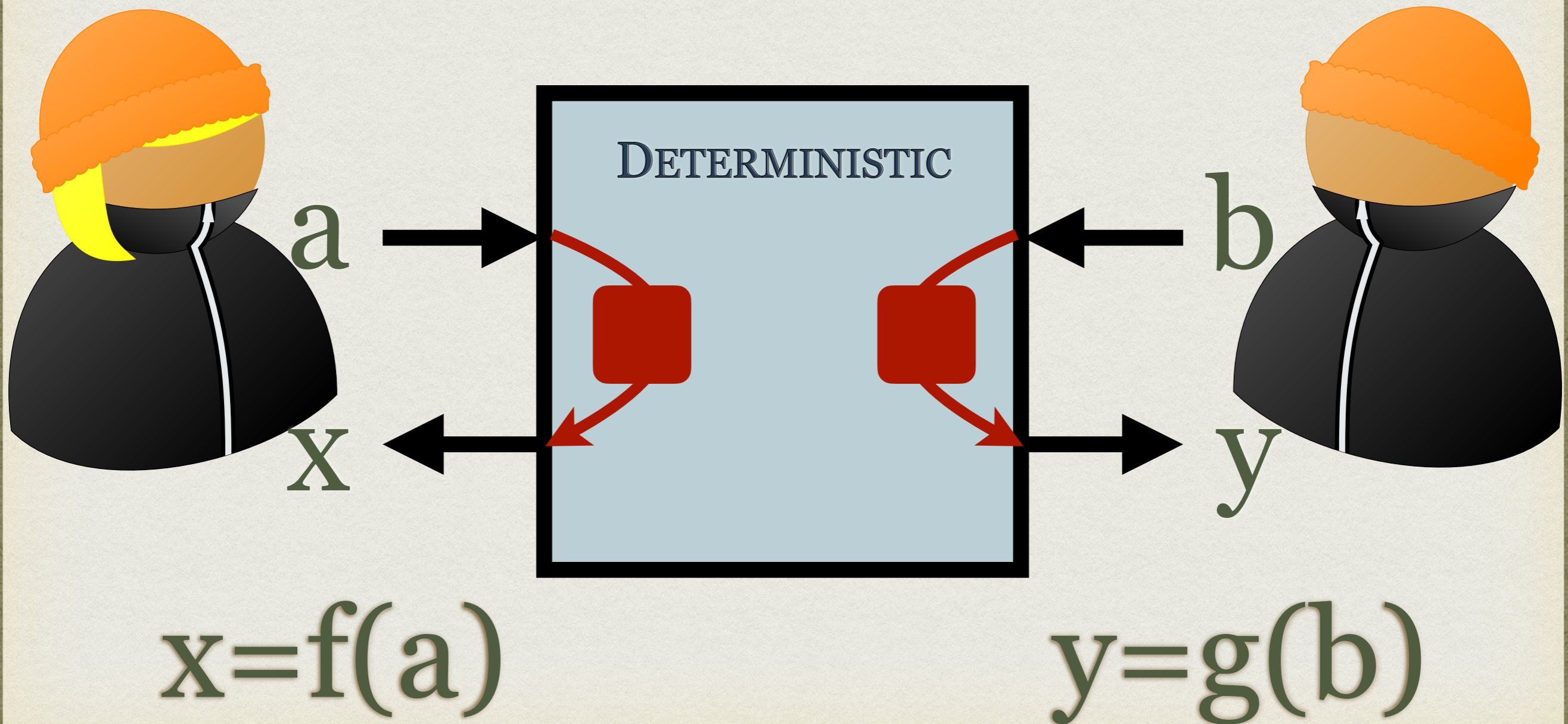

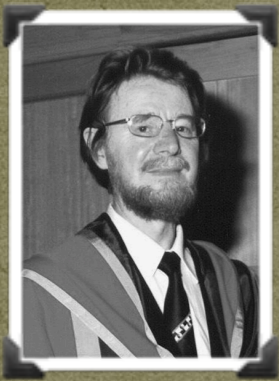

LOCALITY

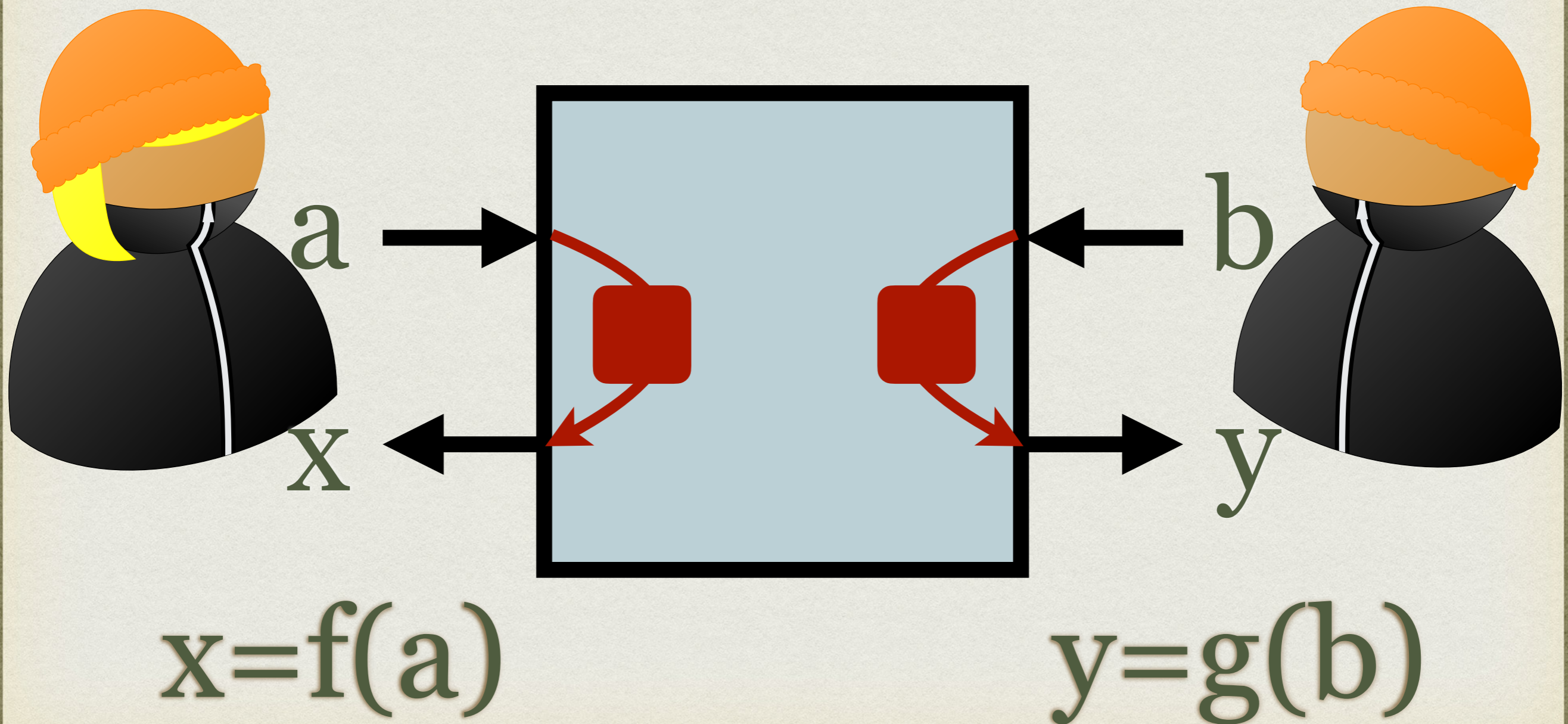

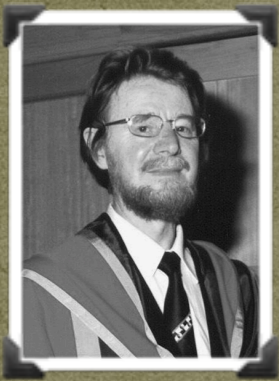

LOCALITY

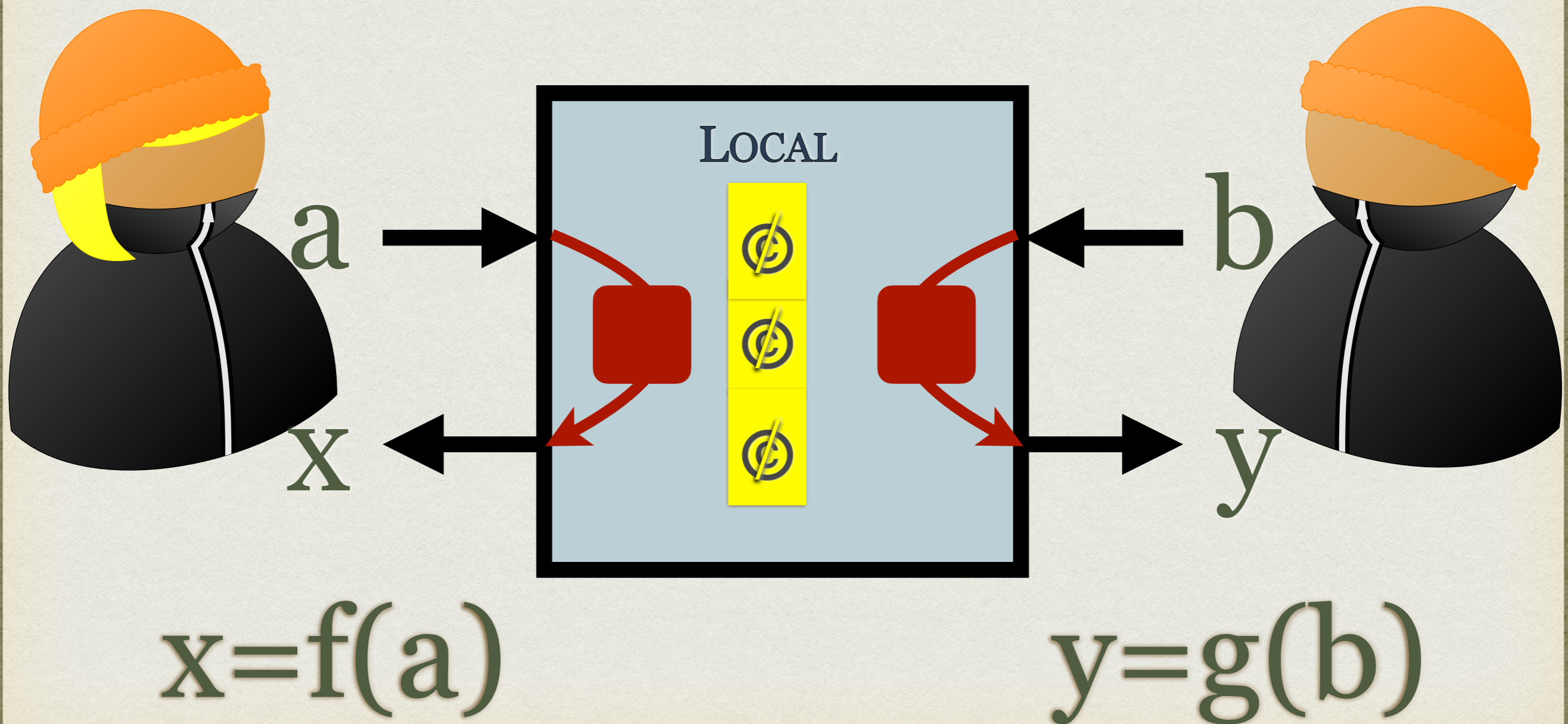

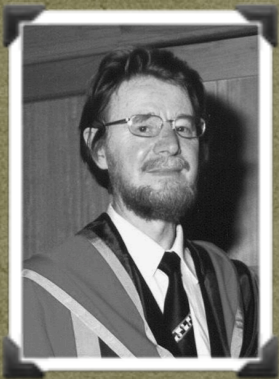

LOCALITY

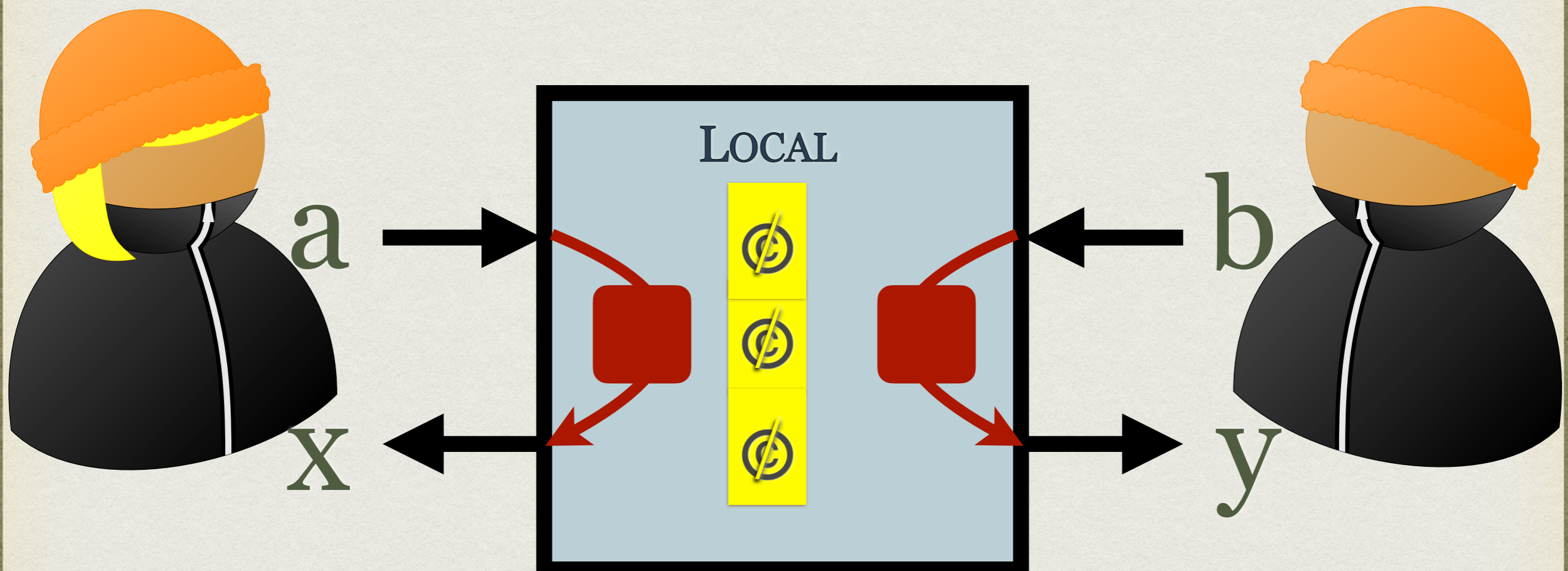

$$x = f(a, @\phi\phi\phi)$$

$$y = g(b, \phi\phi\phi)$$

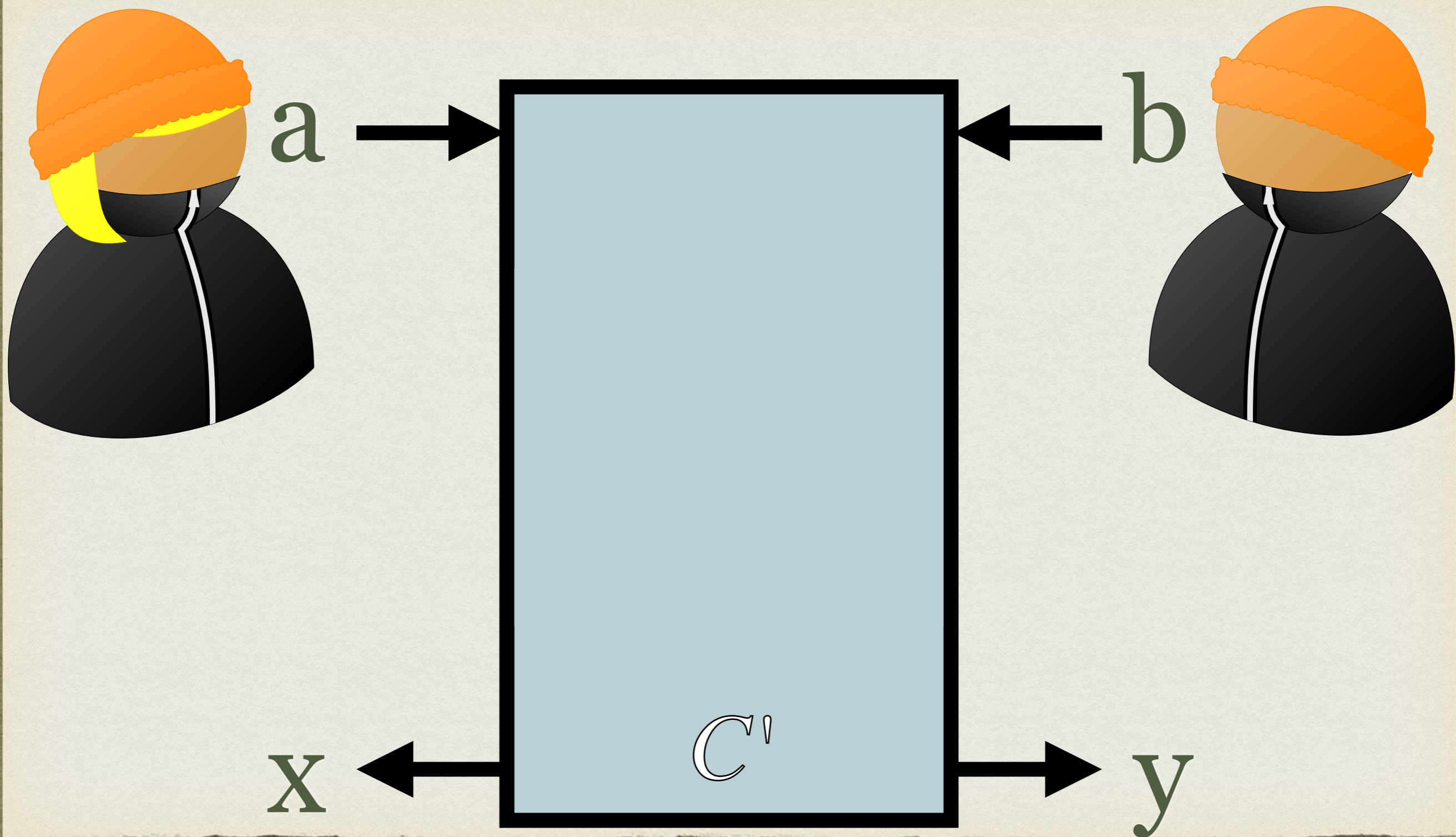
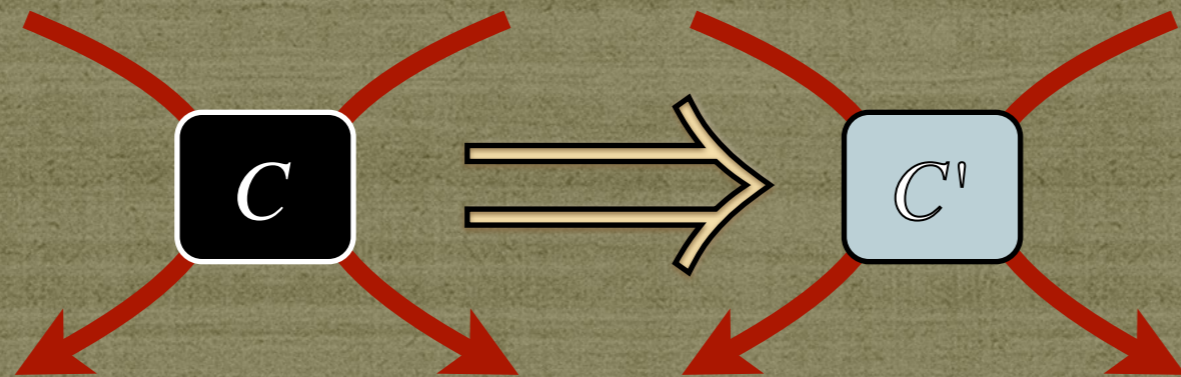

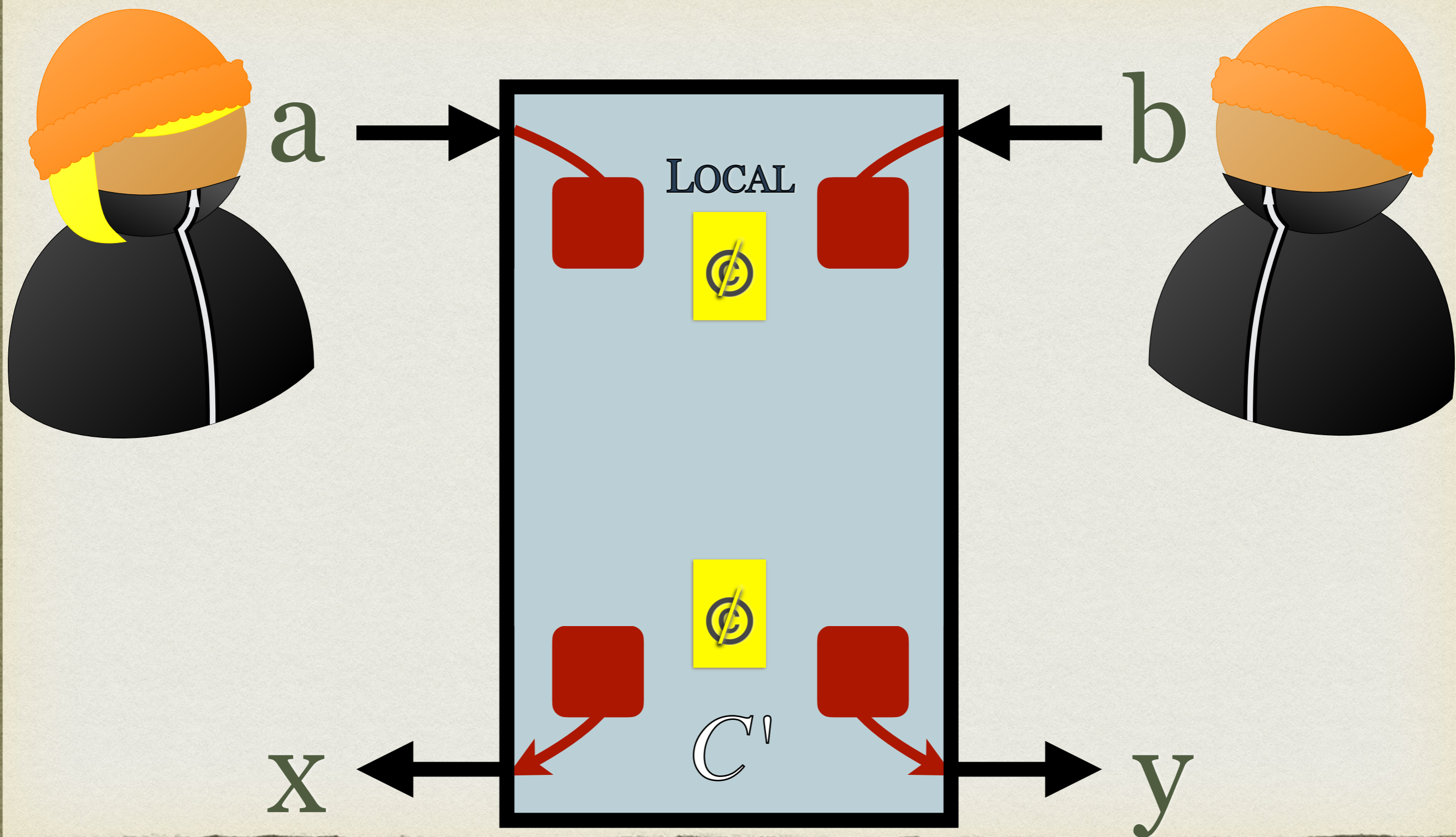
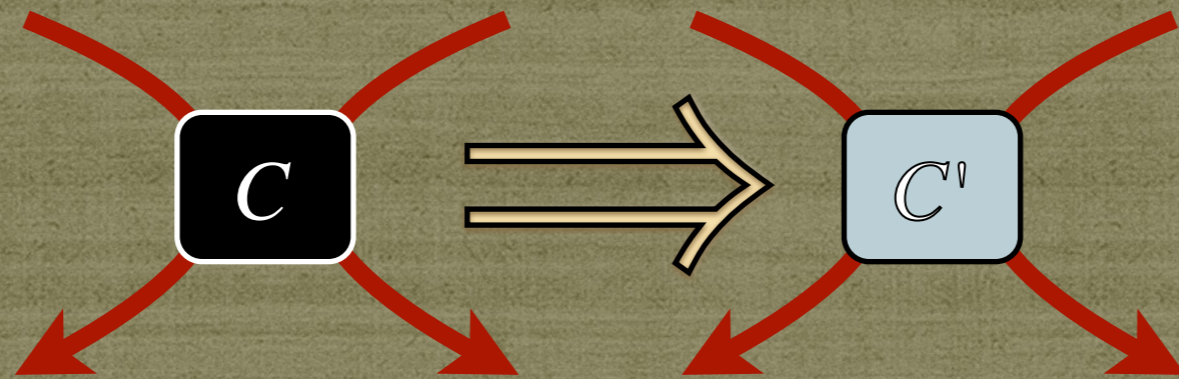

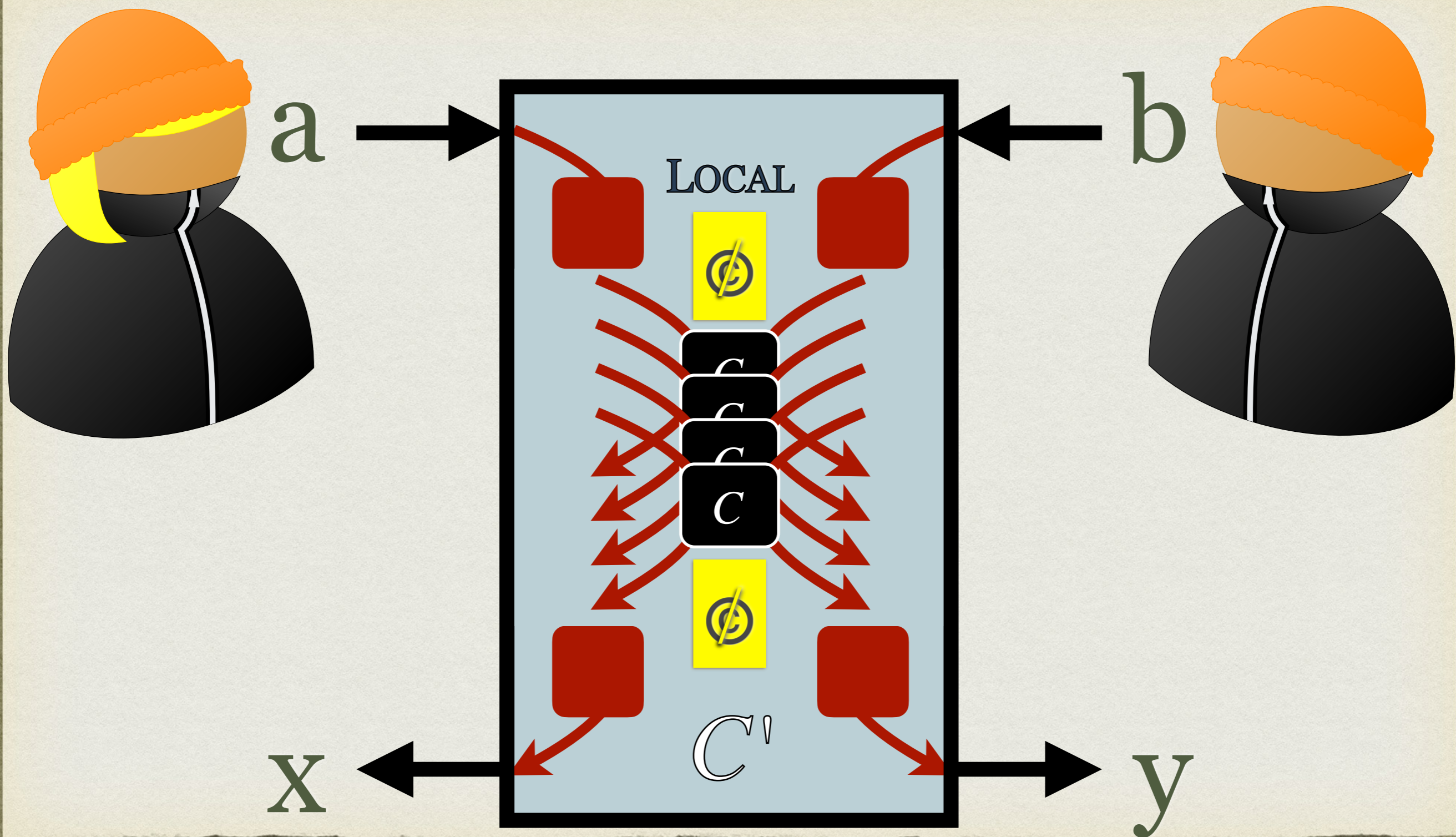
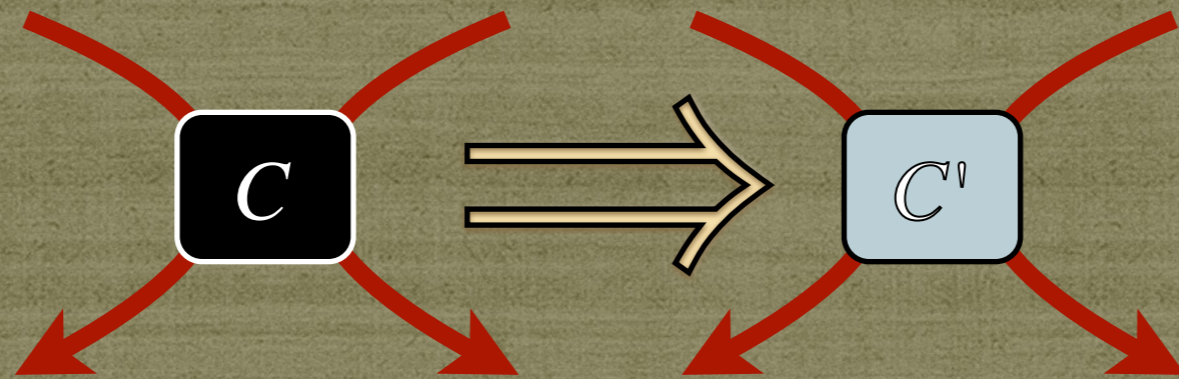

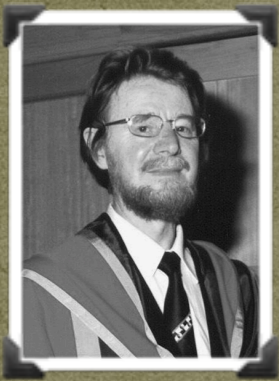

QUANTUM NON-LOCALITY

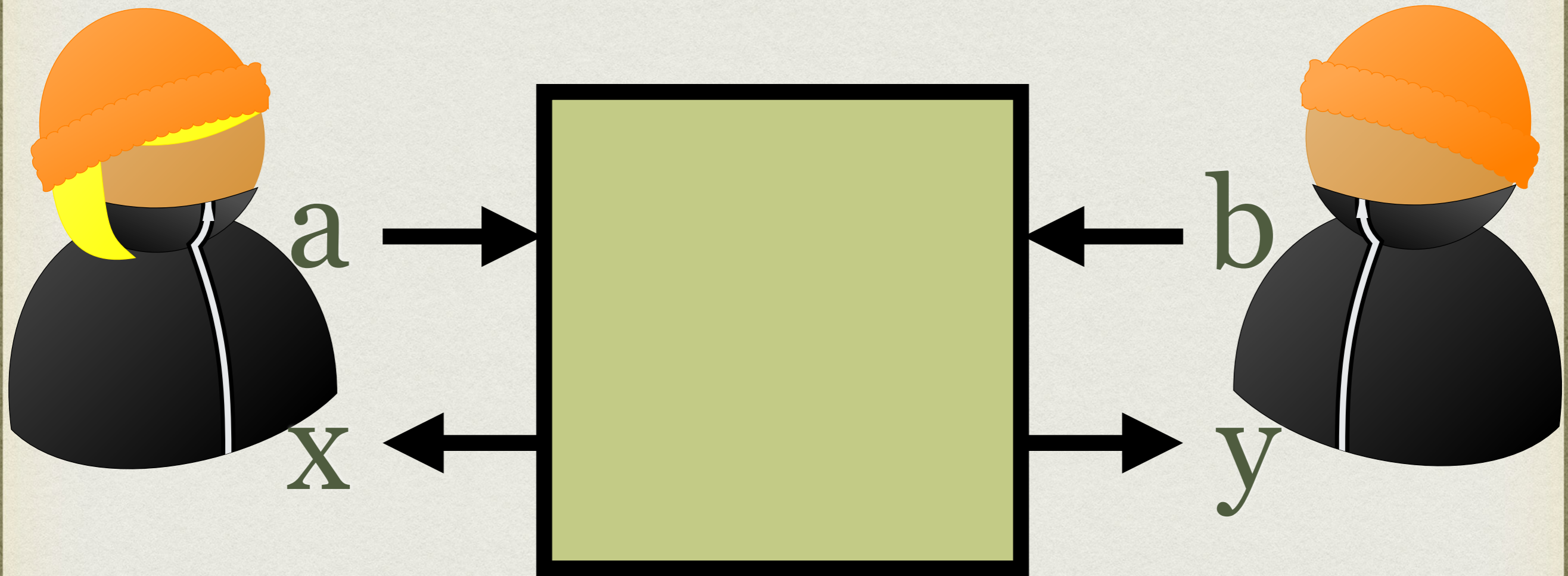

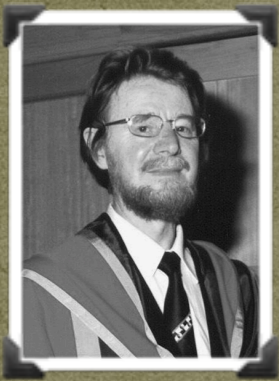

QUANTUM NON-LOCALITY

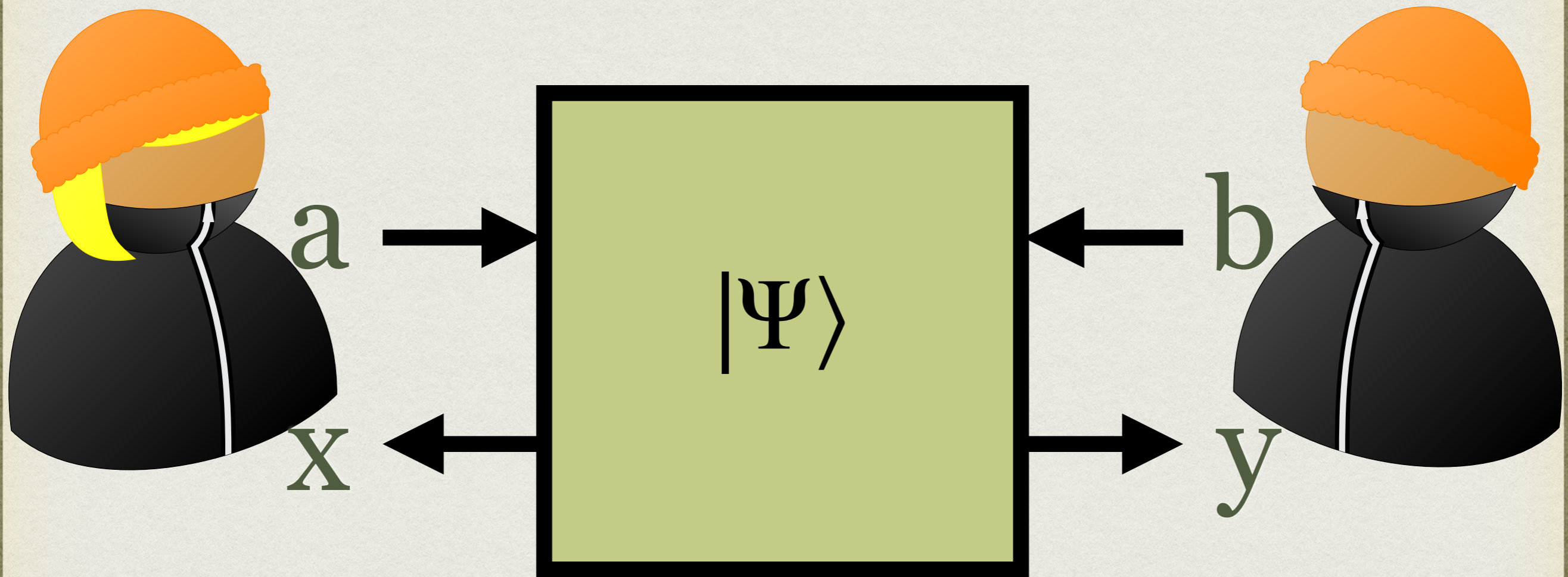

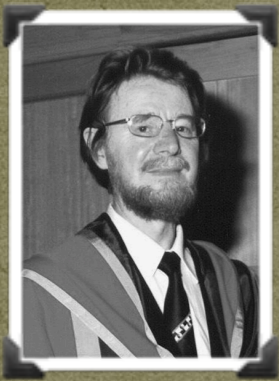

QUANTUM NON-LOCALITY

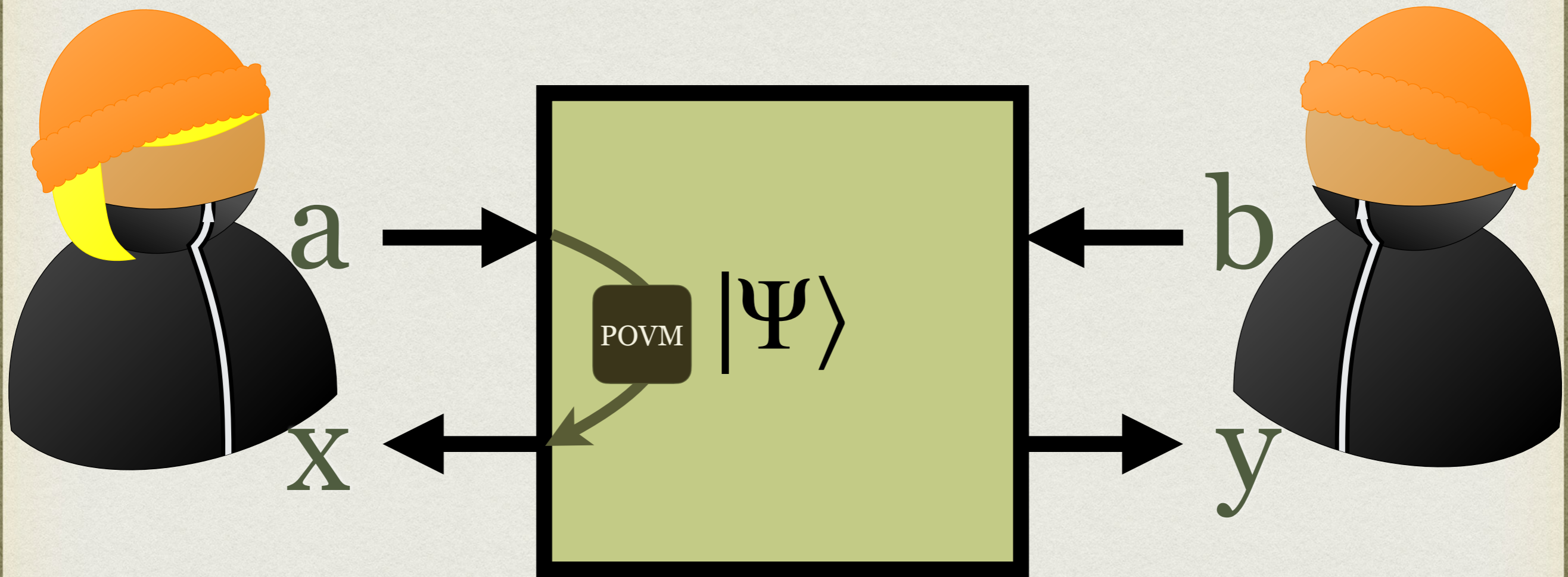

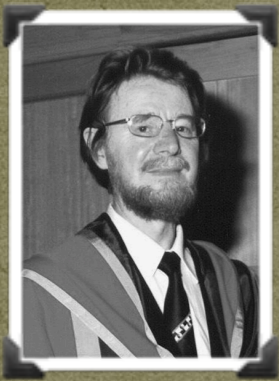

QUANTUM NON-LOCALITY

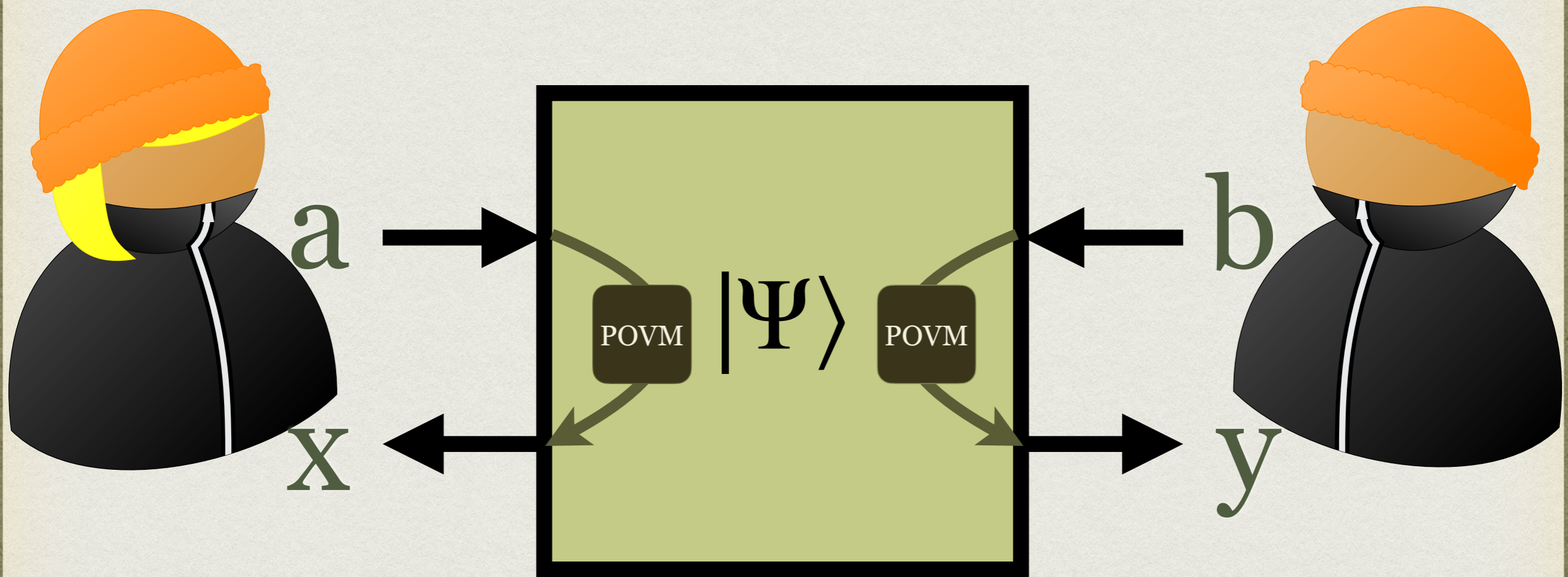

NON-LOCALITY HIERARCHY



SIG

NON-LOCALITY HIERARCHY

SIG = all two-party correlations



SIG

NON-LOCALITY HIERARCHY

SIG = all two-party correlations

bi-SIG

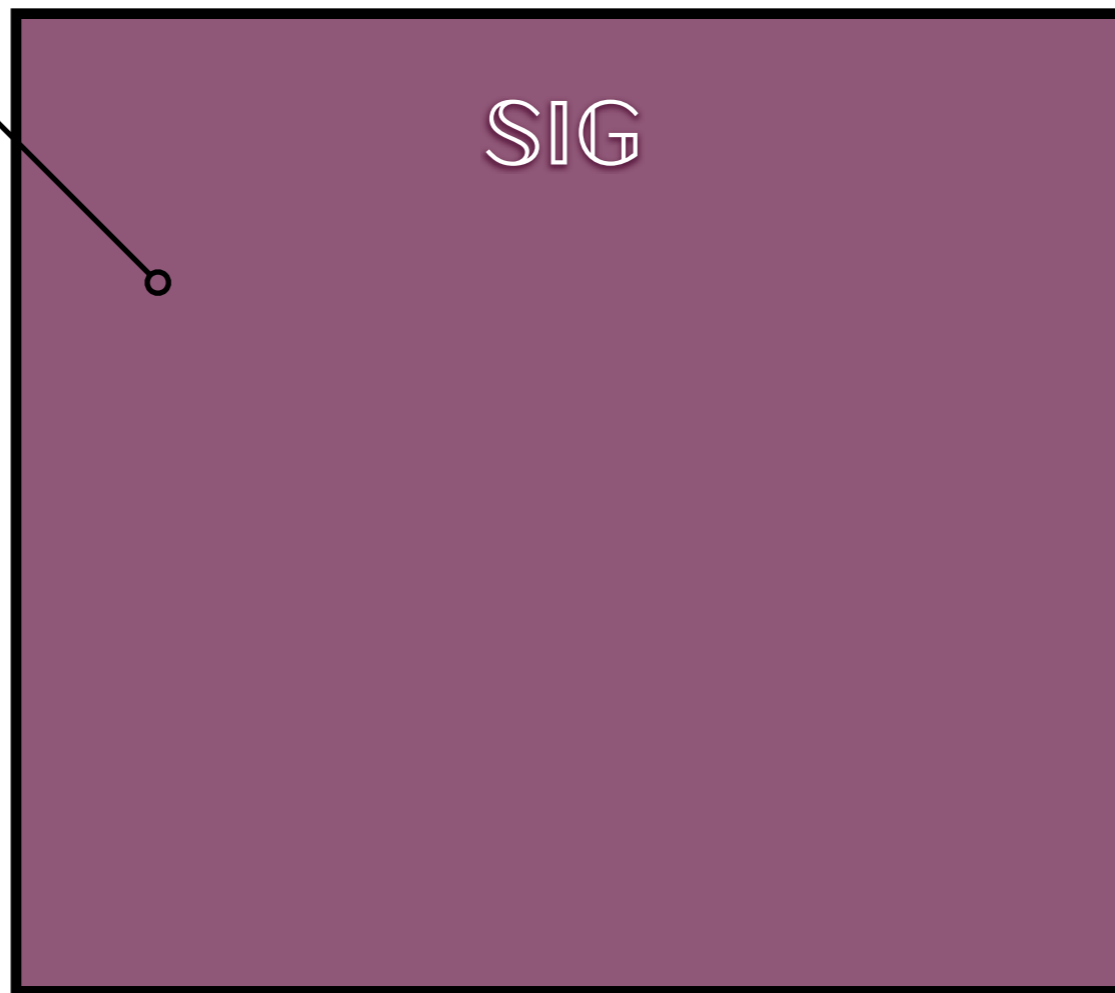

NON-LOCALITY HIERARCHY



SIG

NON-LOCALITY HIERARCHY

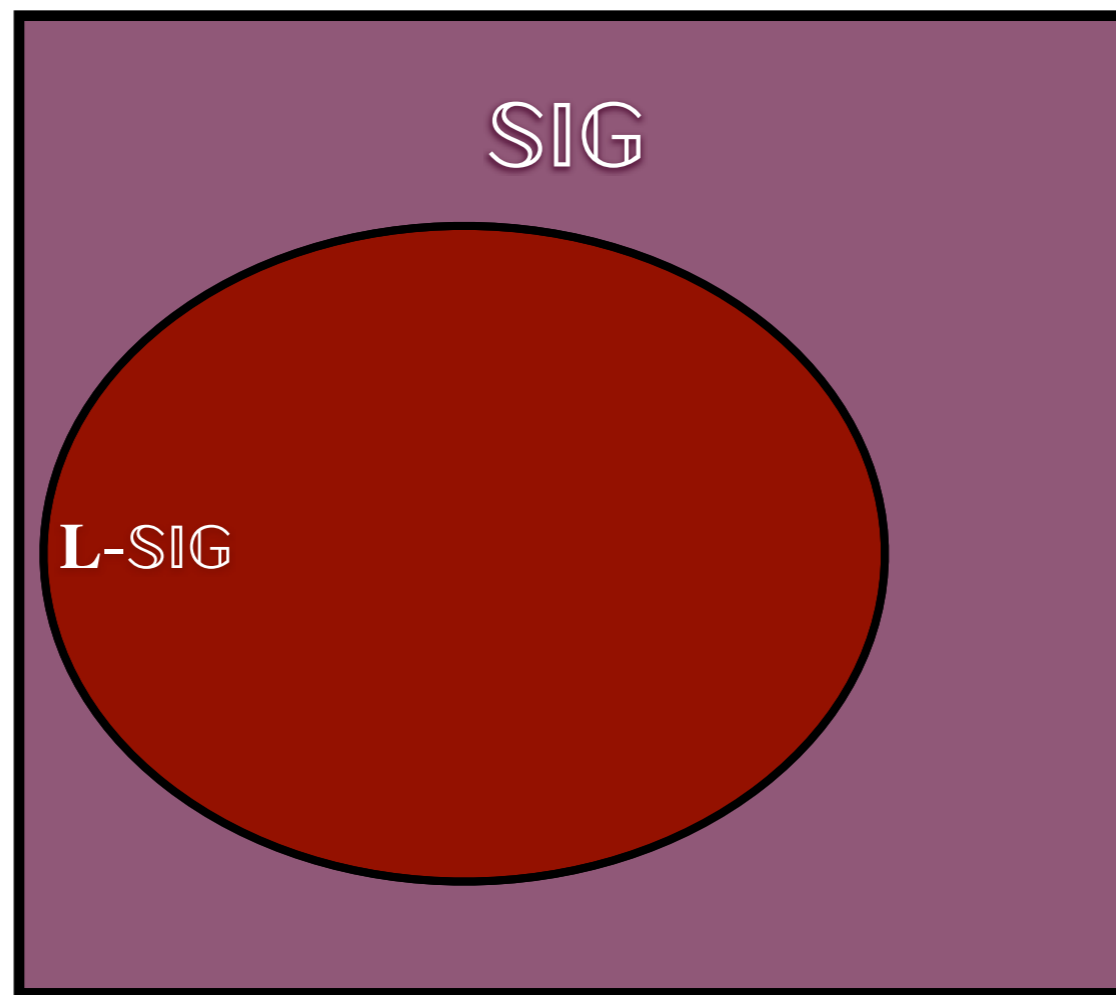

NON-LOCALITY HIERARCHY

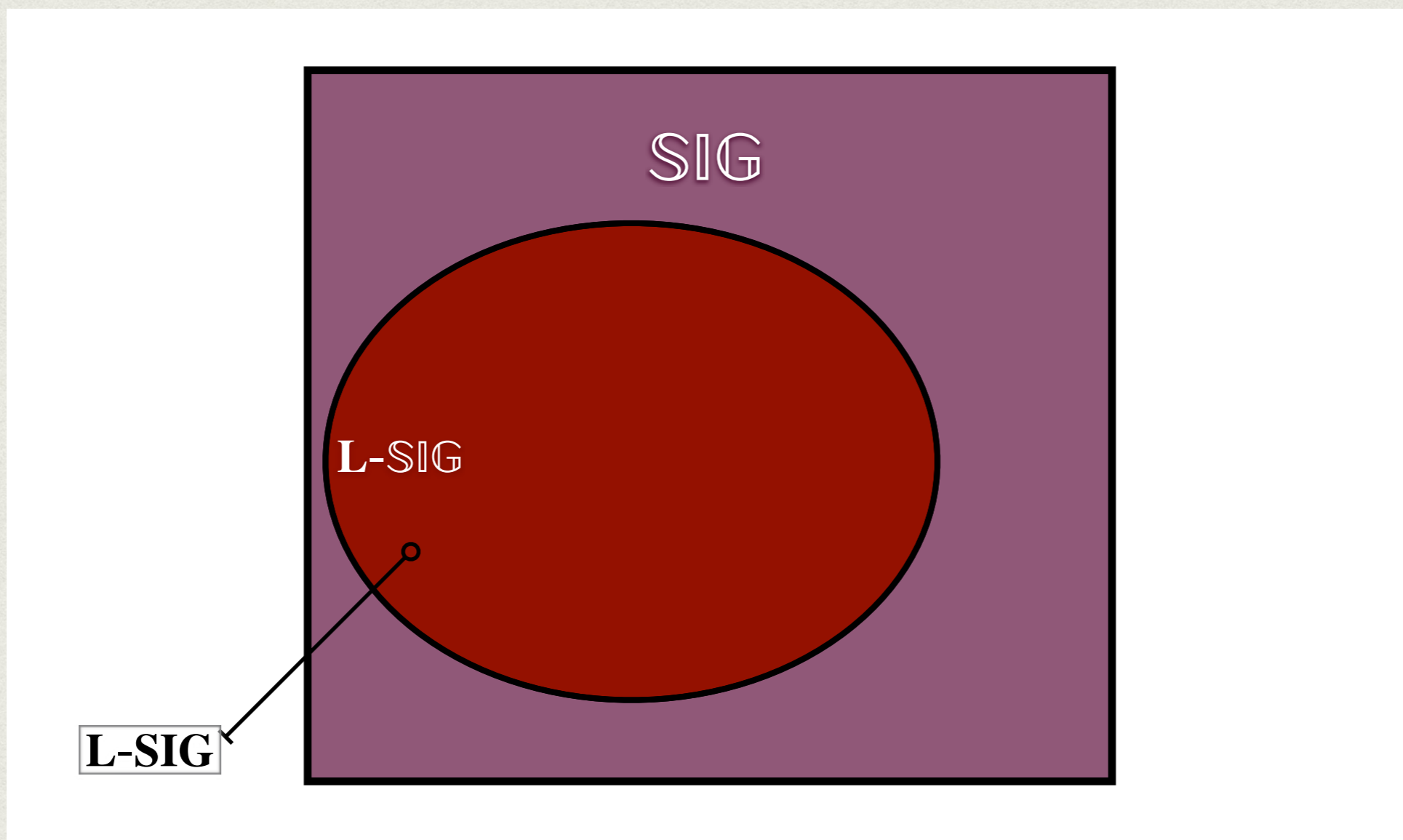

NON-LOCALITY HIERARCHY

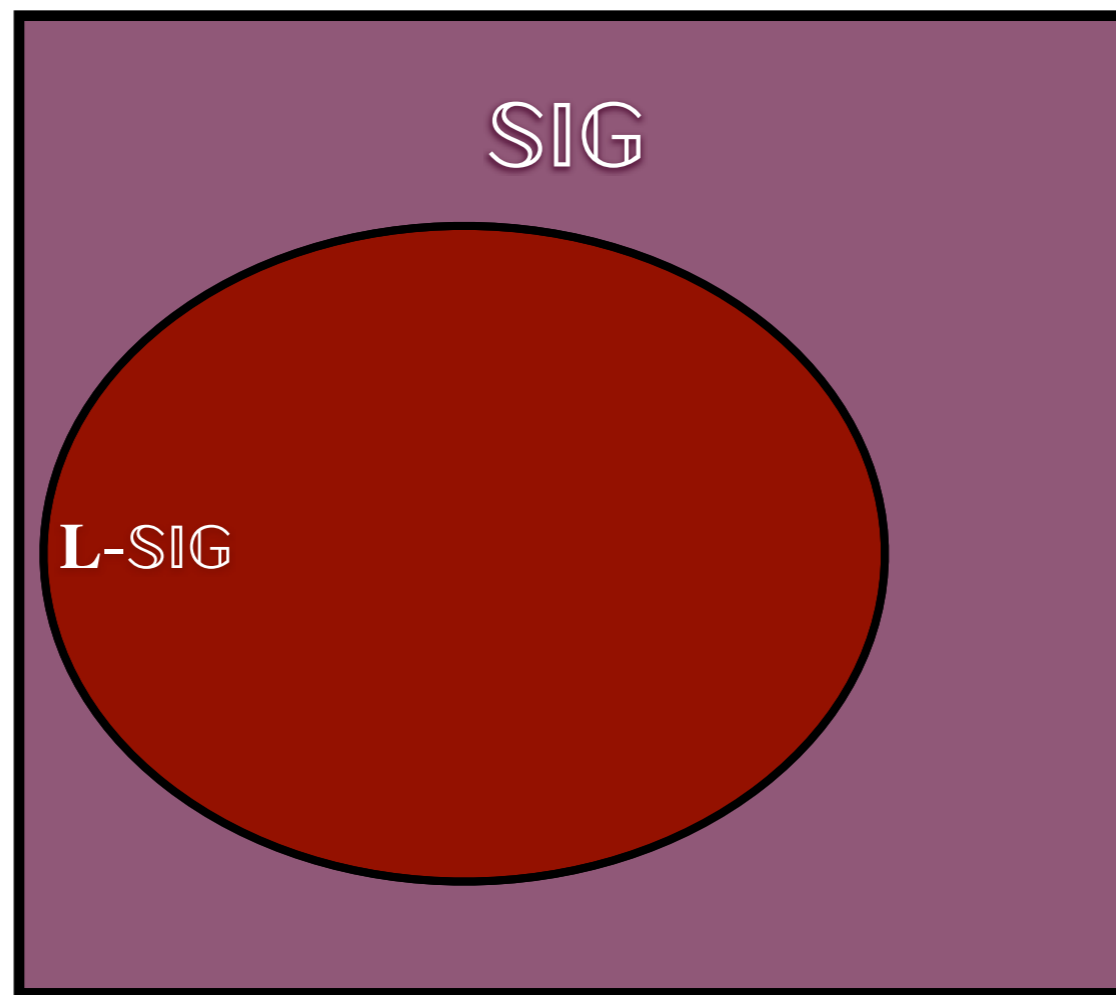

NON-LOCALITY HIERARCHY

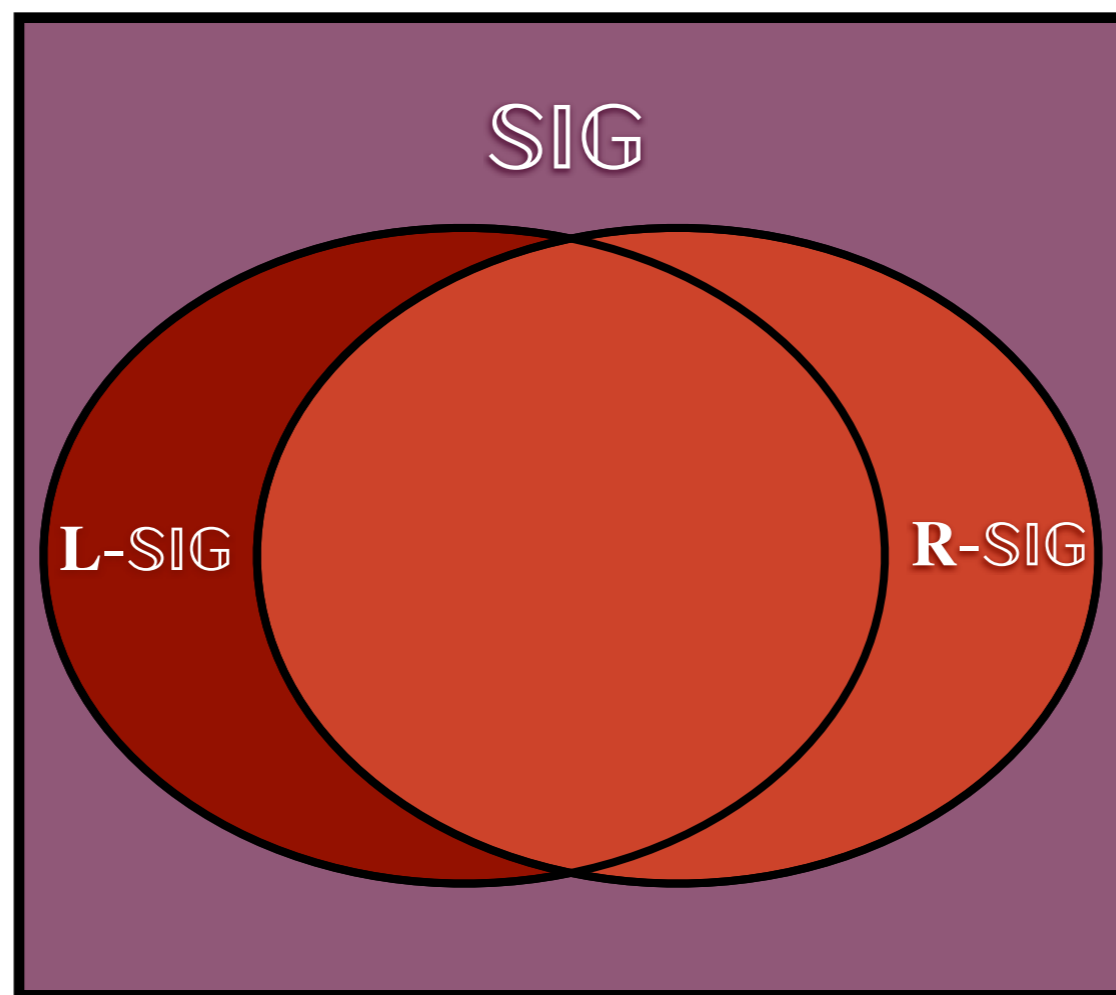

NON-LOCALITY HIERARCHY

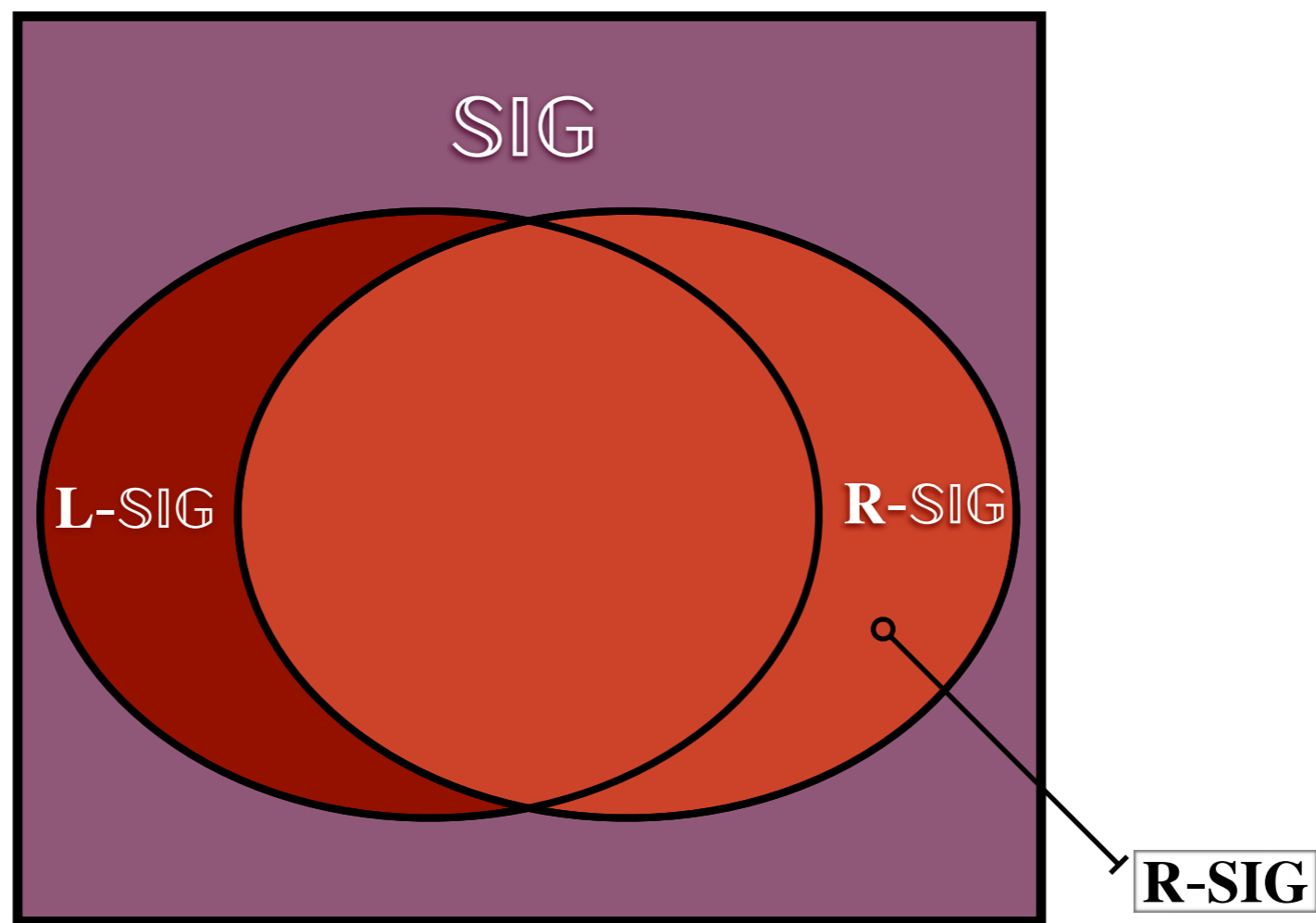

NON-LOCALITY HIERARCHY

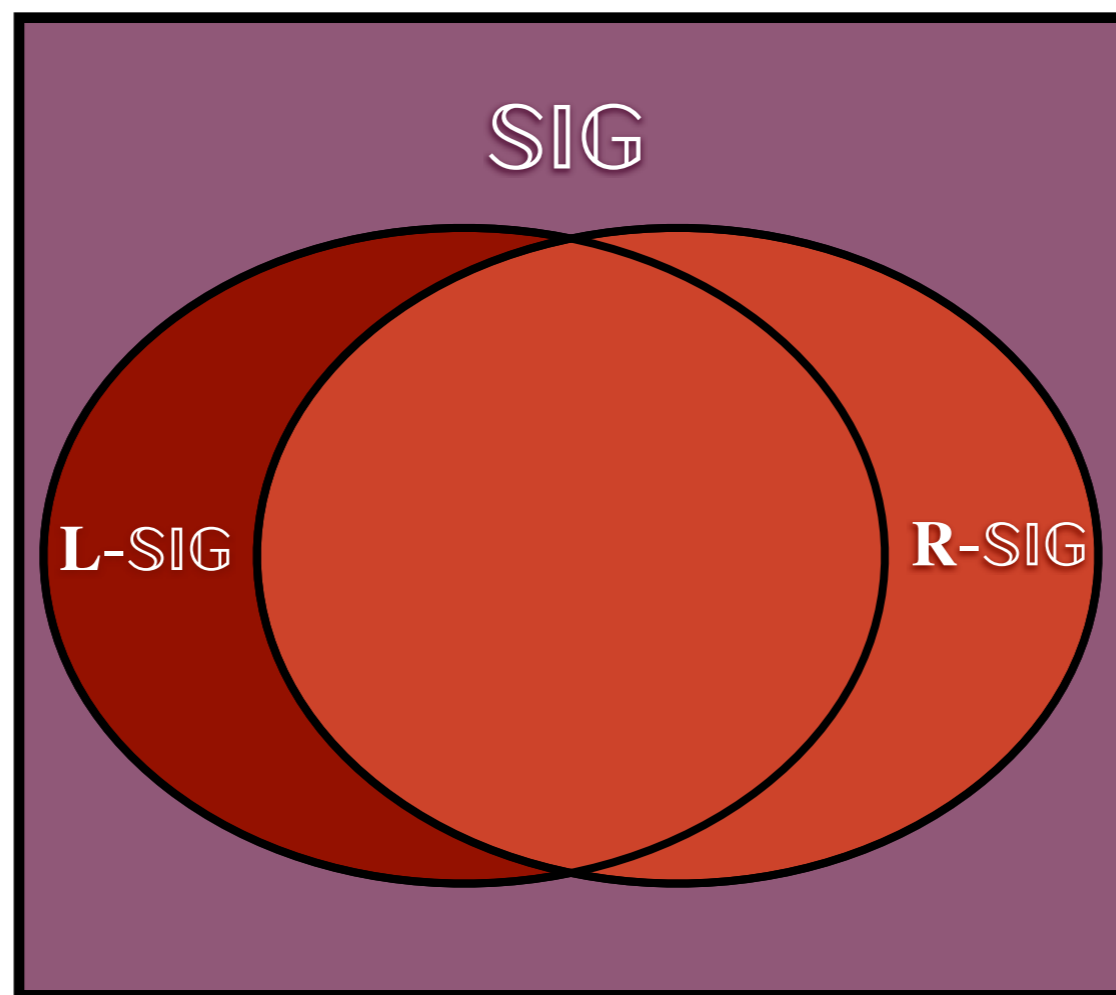

NON-LOCALITY HIERARCHY

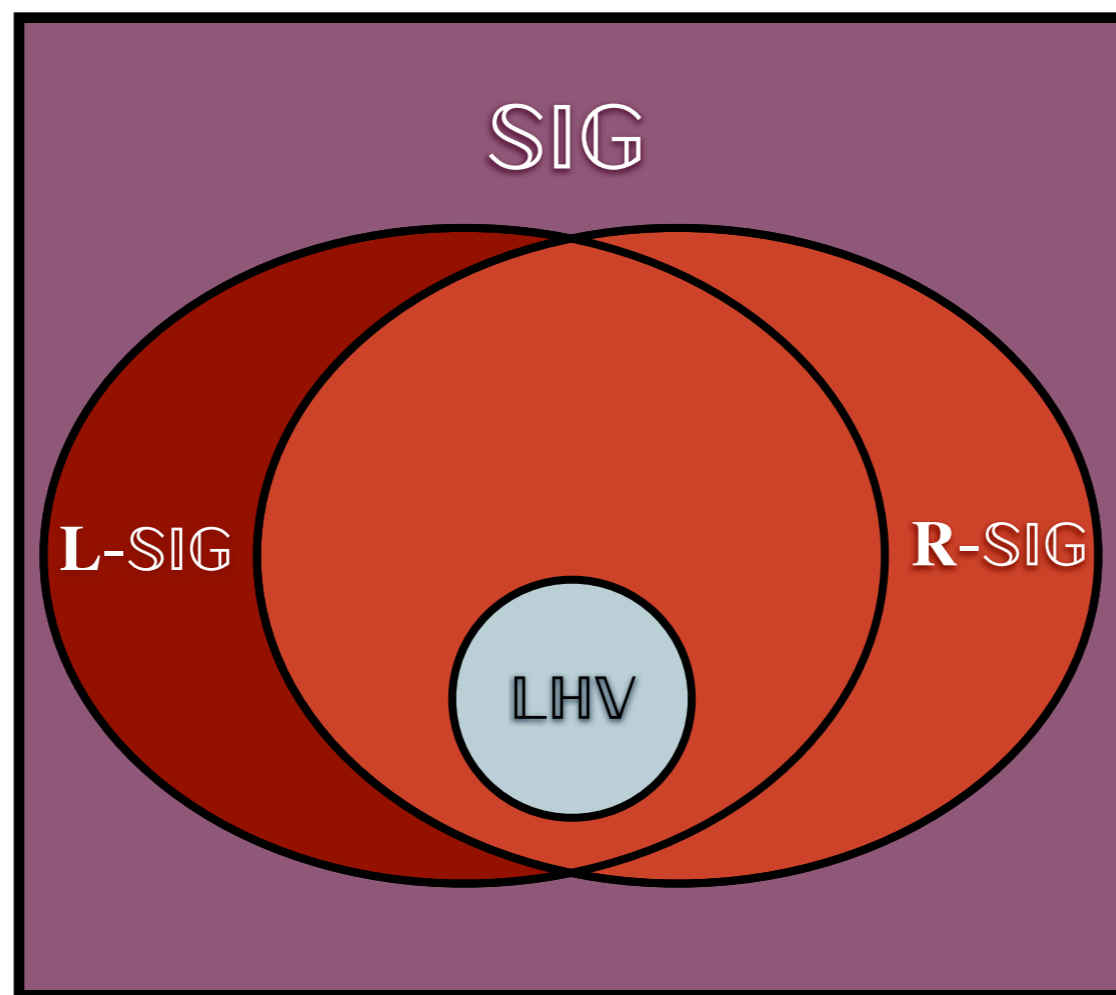

NON-LOCALITY HIERARCHY

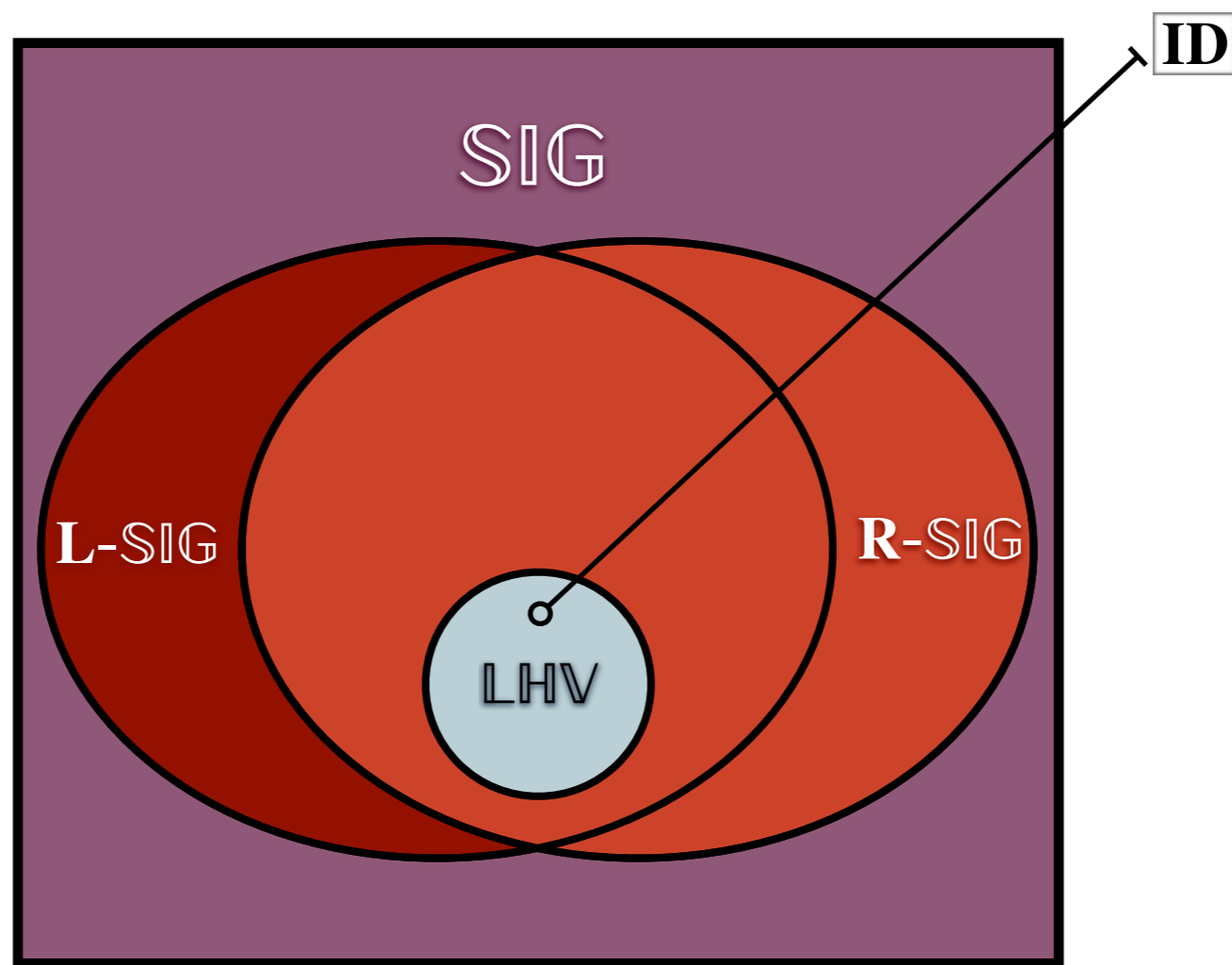

NON-LOCALITY HIERARCHY

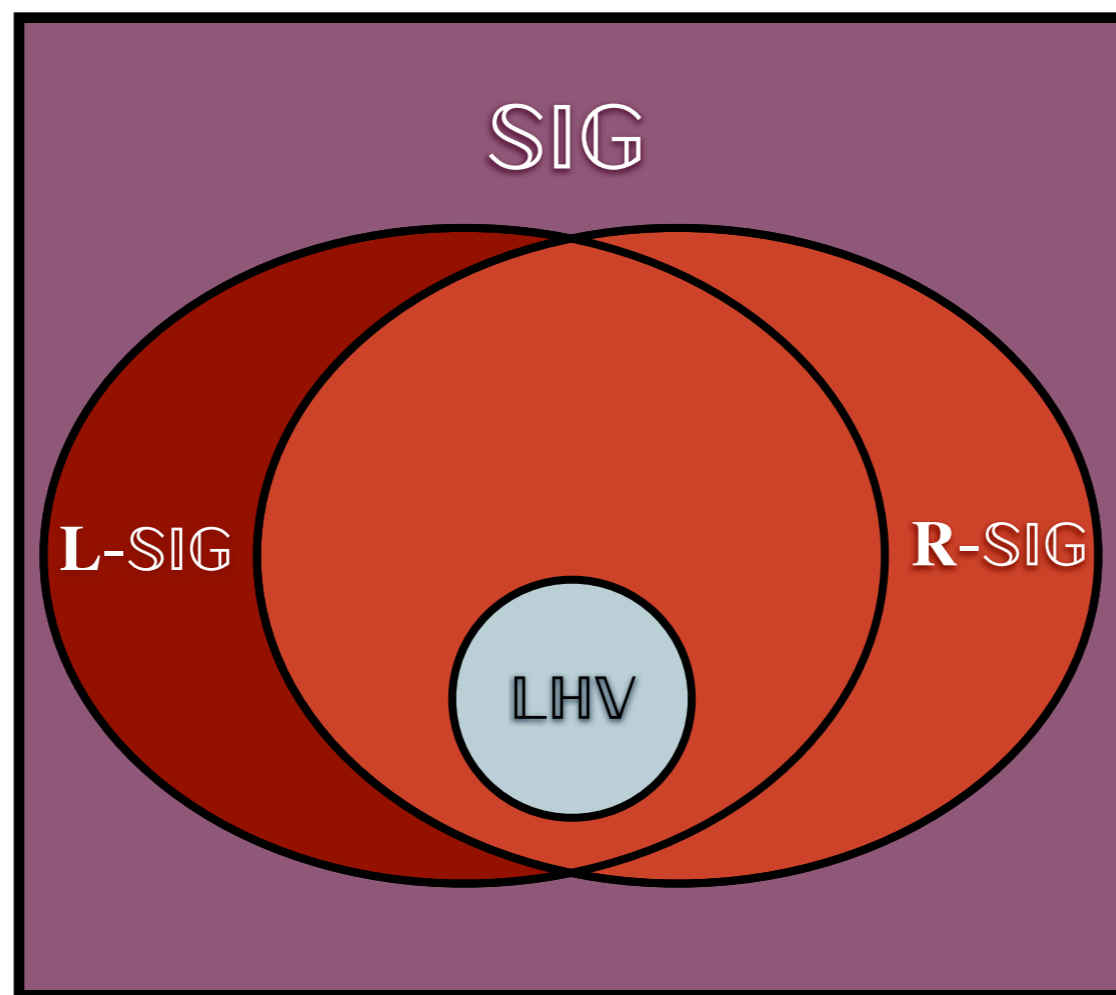

NON-LOCALITY HIERARCHY

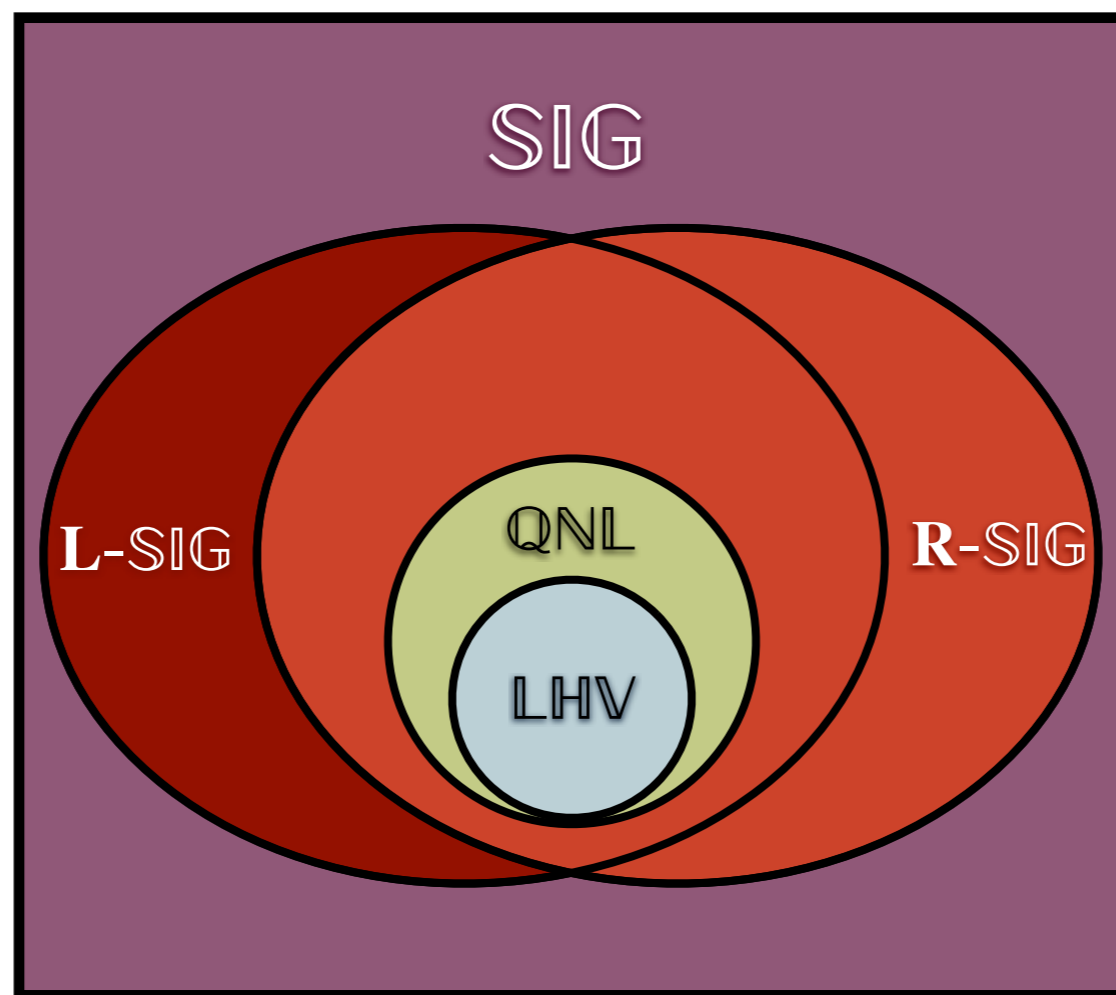

NON-LOCALITY HIERARCHY

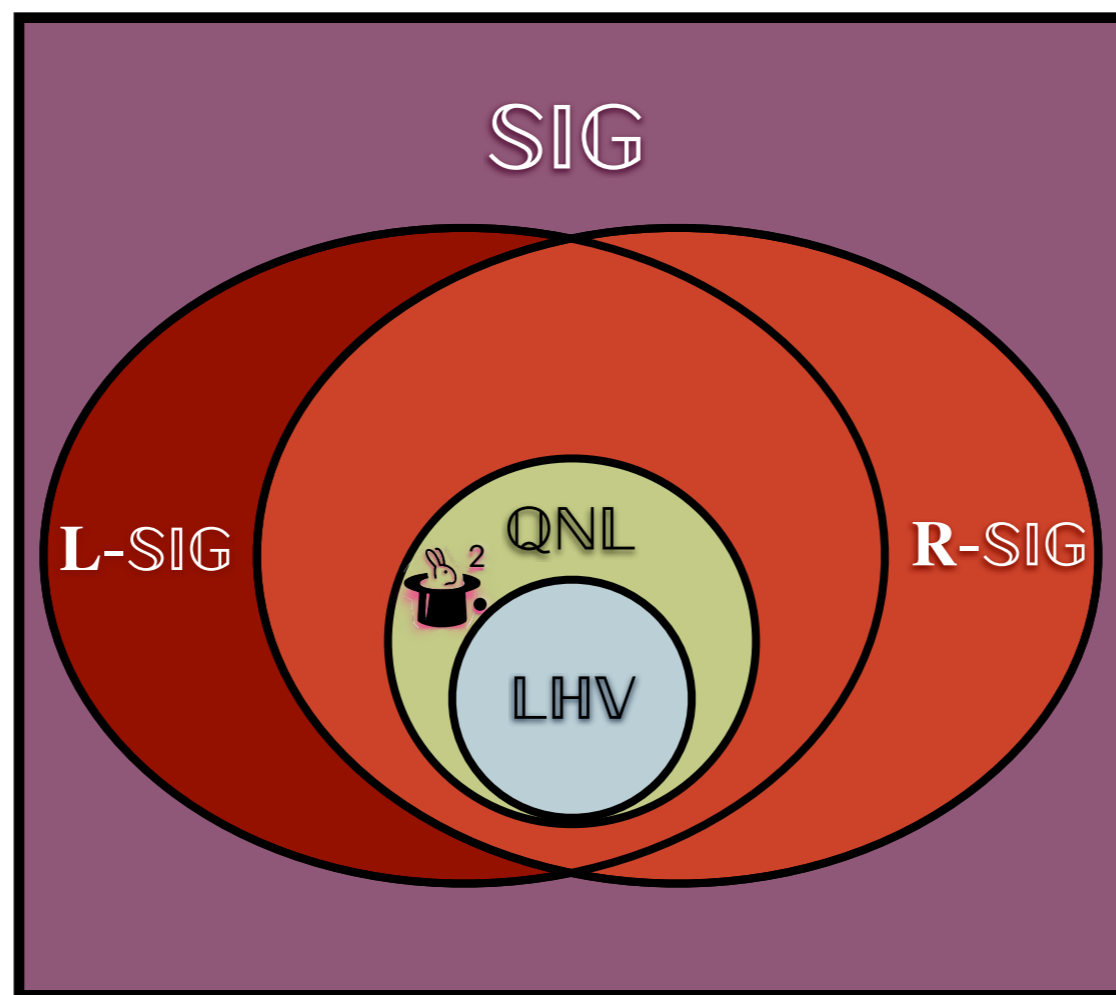

NON-LOCALITY HIERARCHY

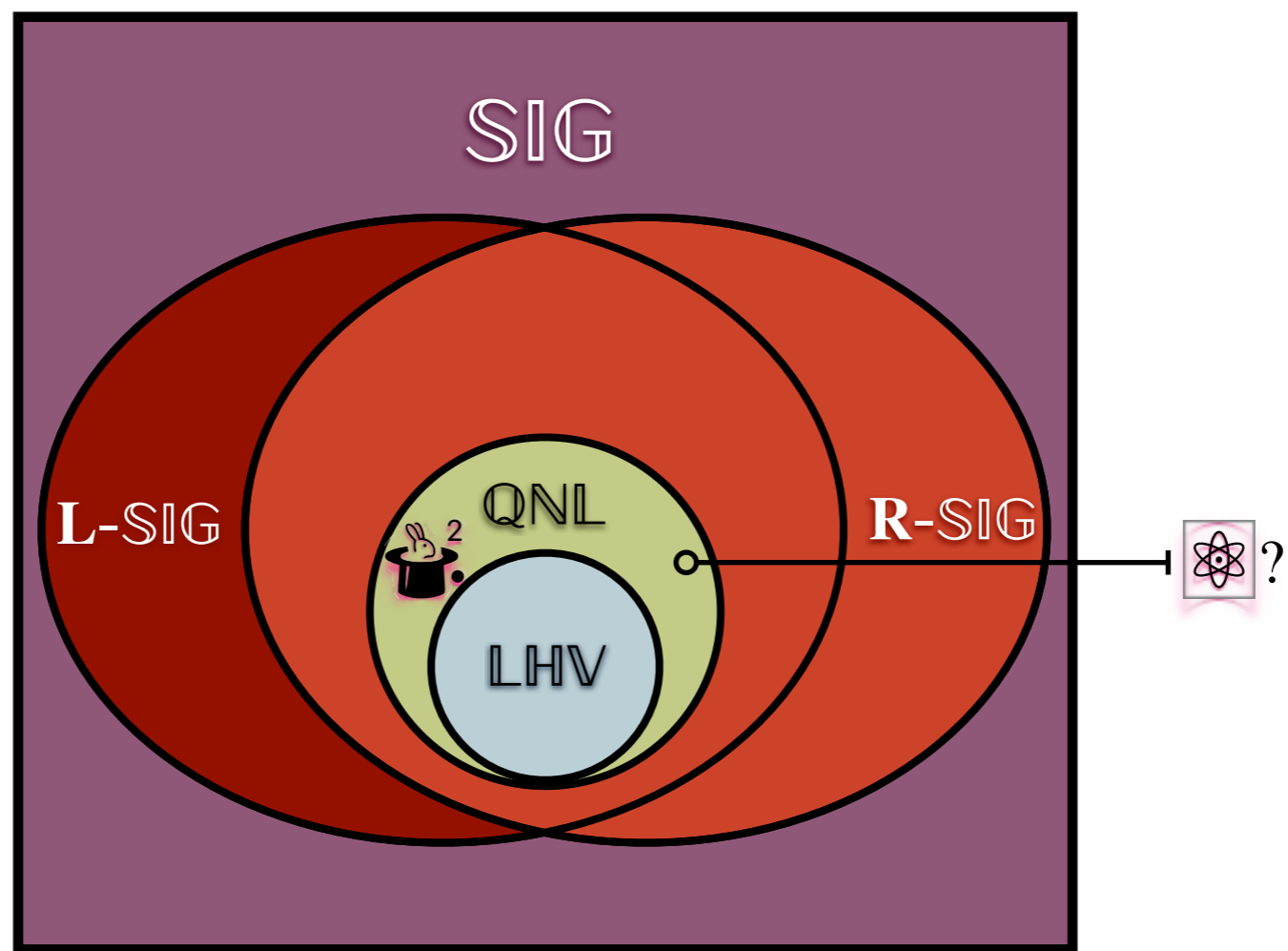

NON-LOCALITY HIERARCHY

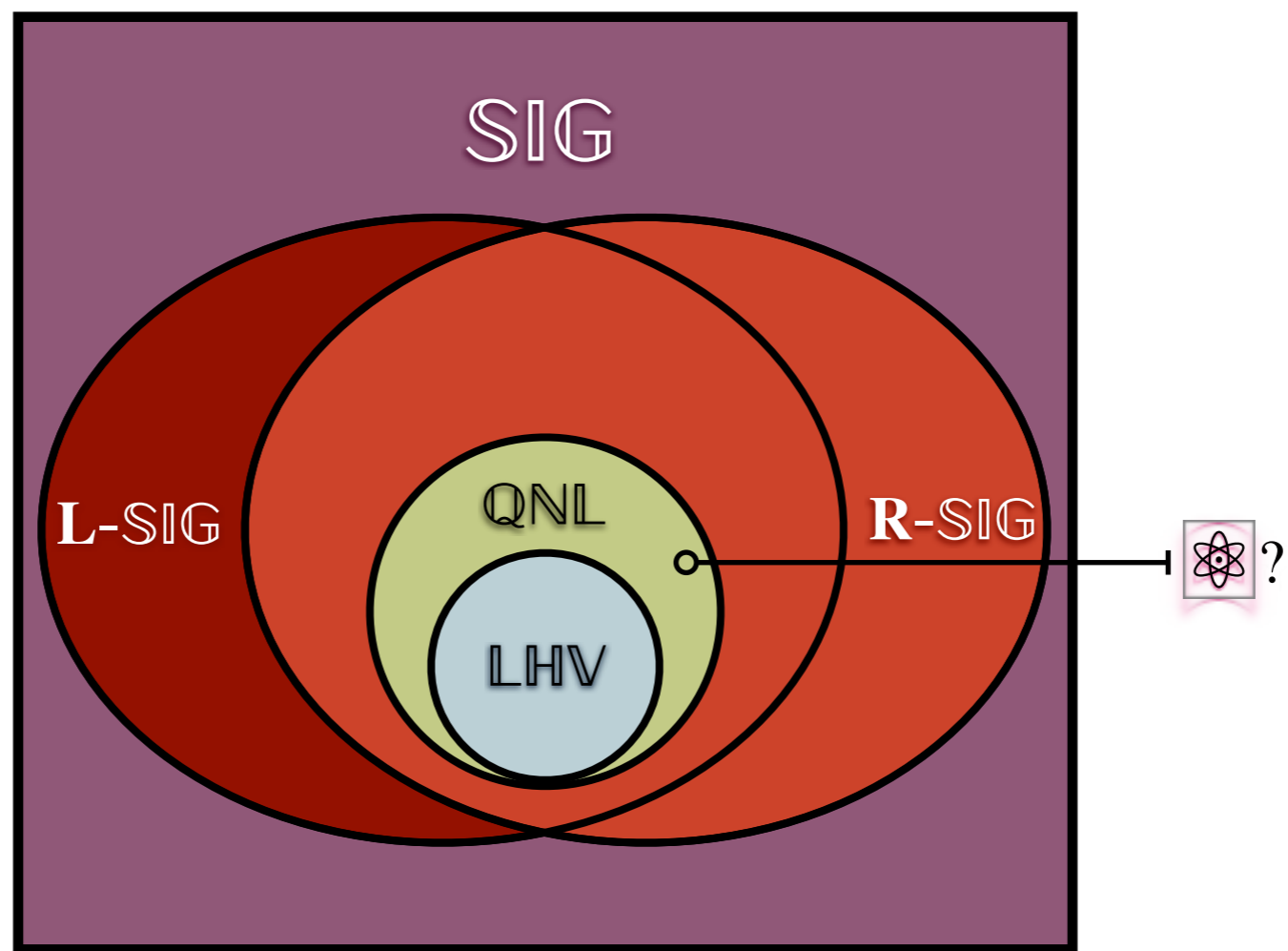

NON-LOCALITY HIERARCHY

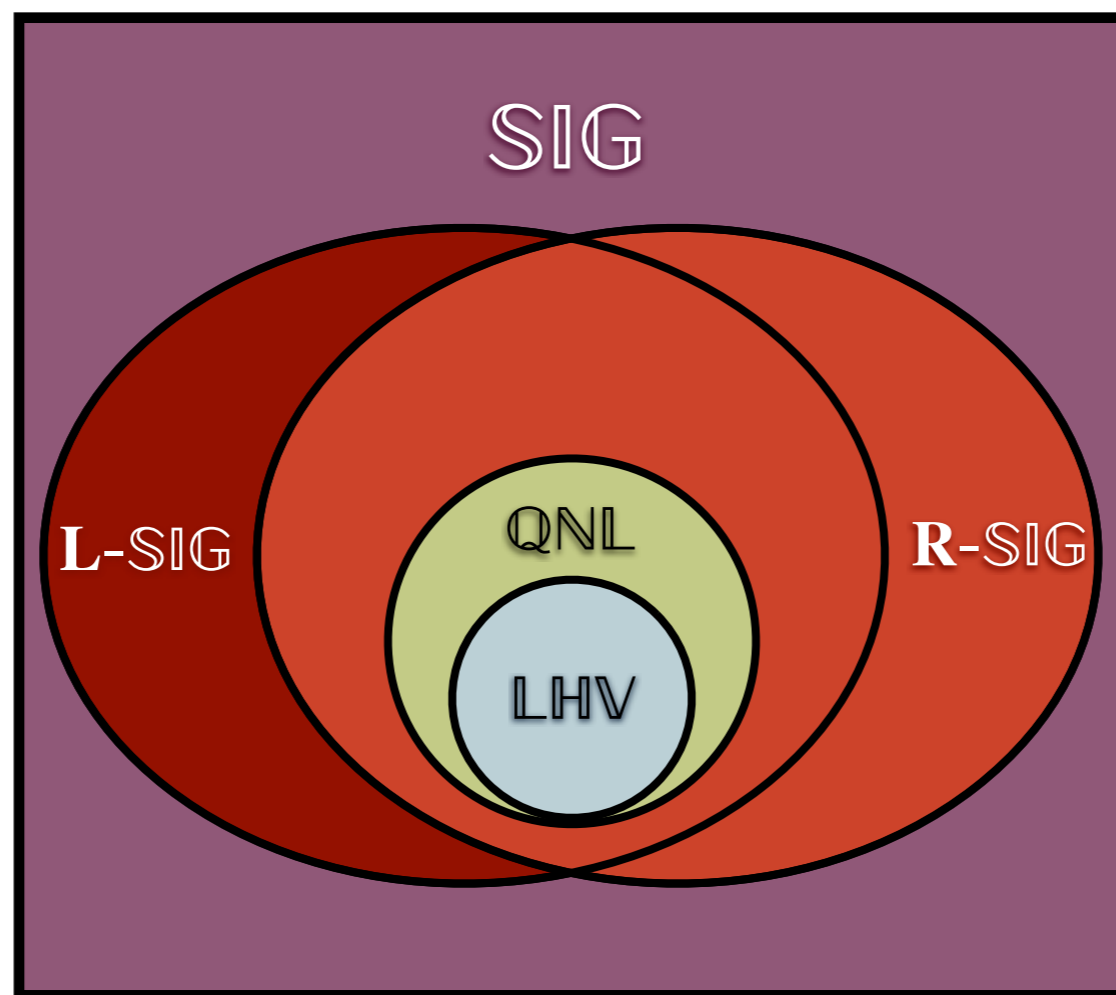

NON-LOCALITY HIERARCHY

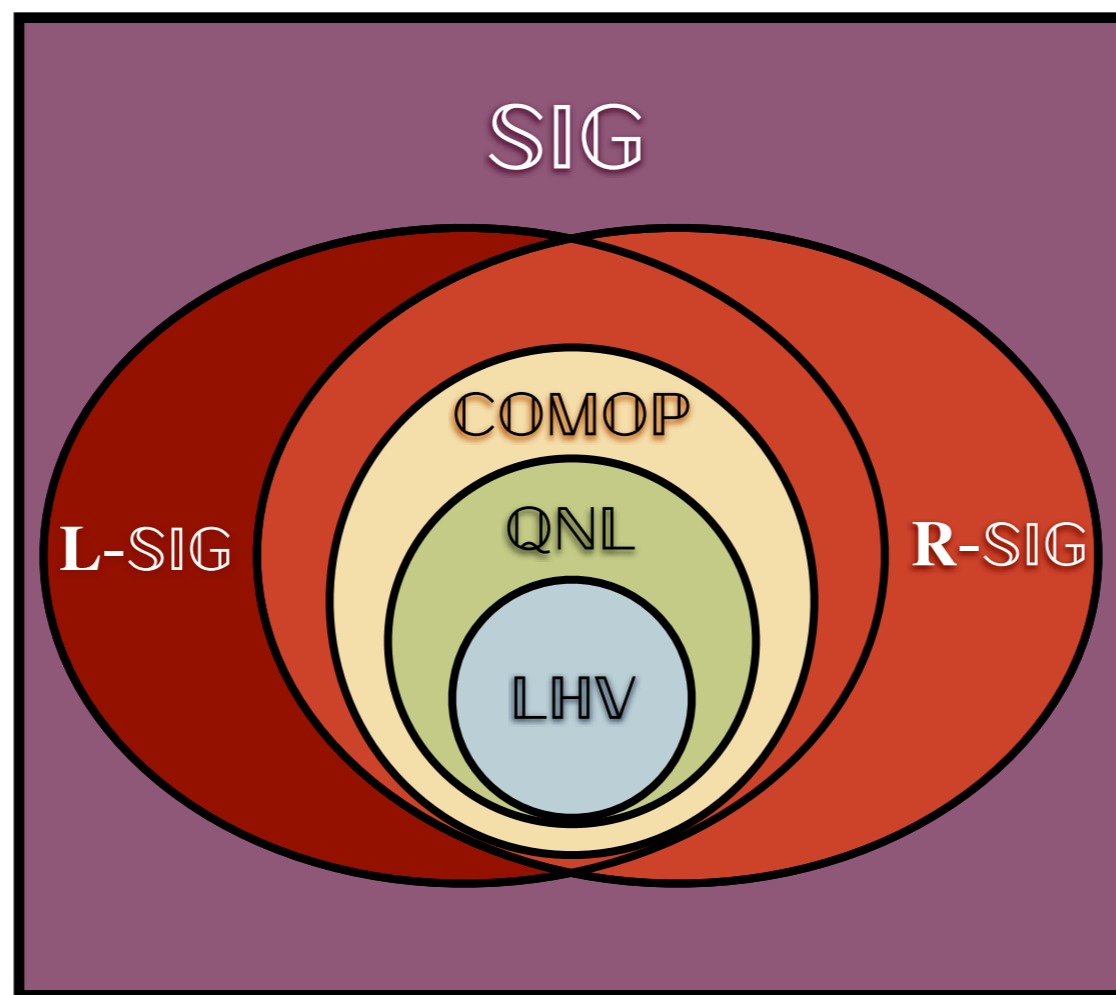

NON-LOCALITY HIERARCHY

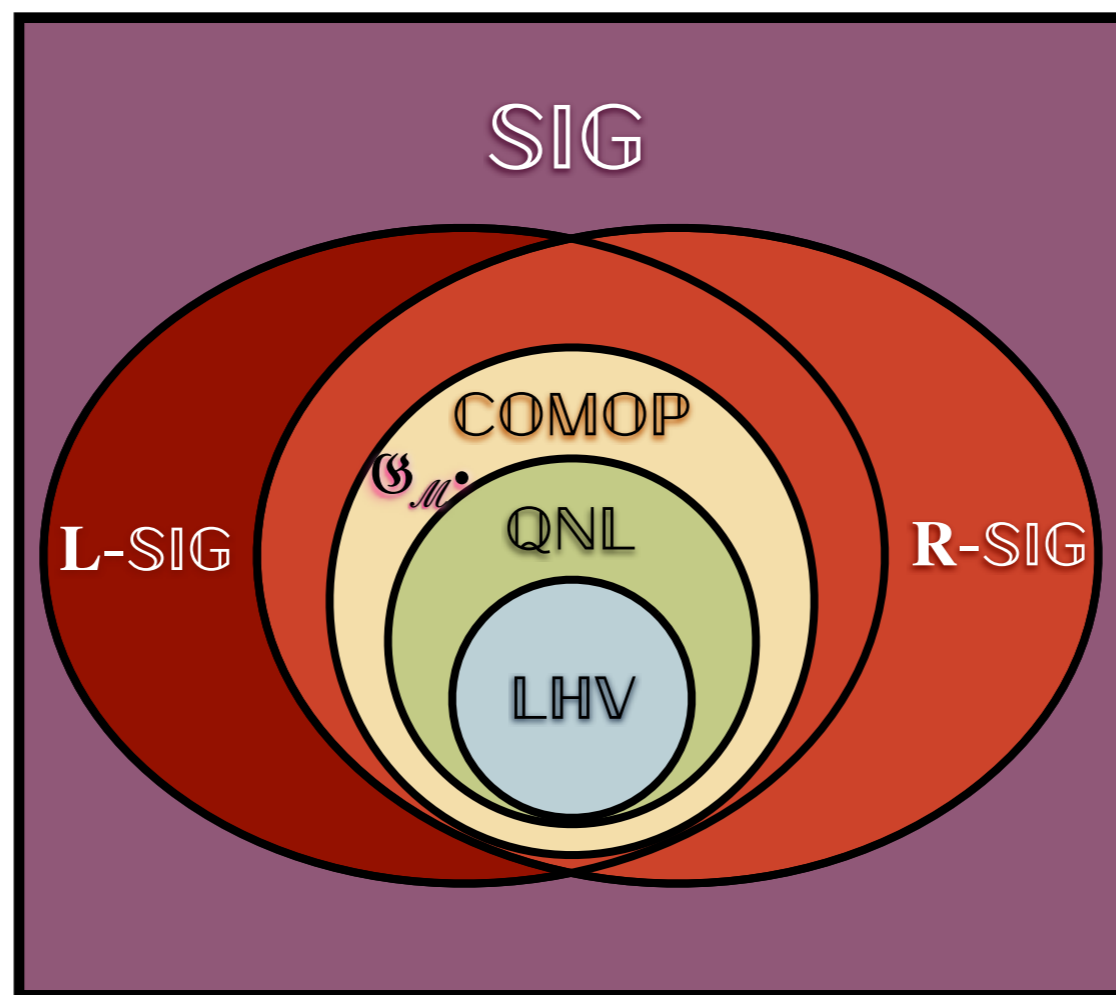

NON-LOCALITY HIERARCHY

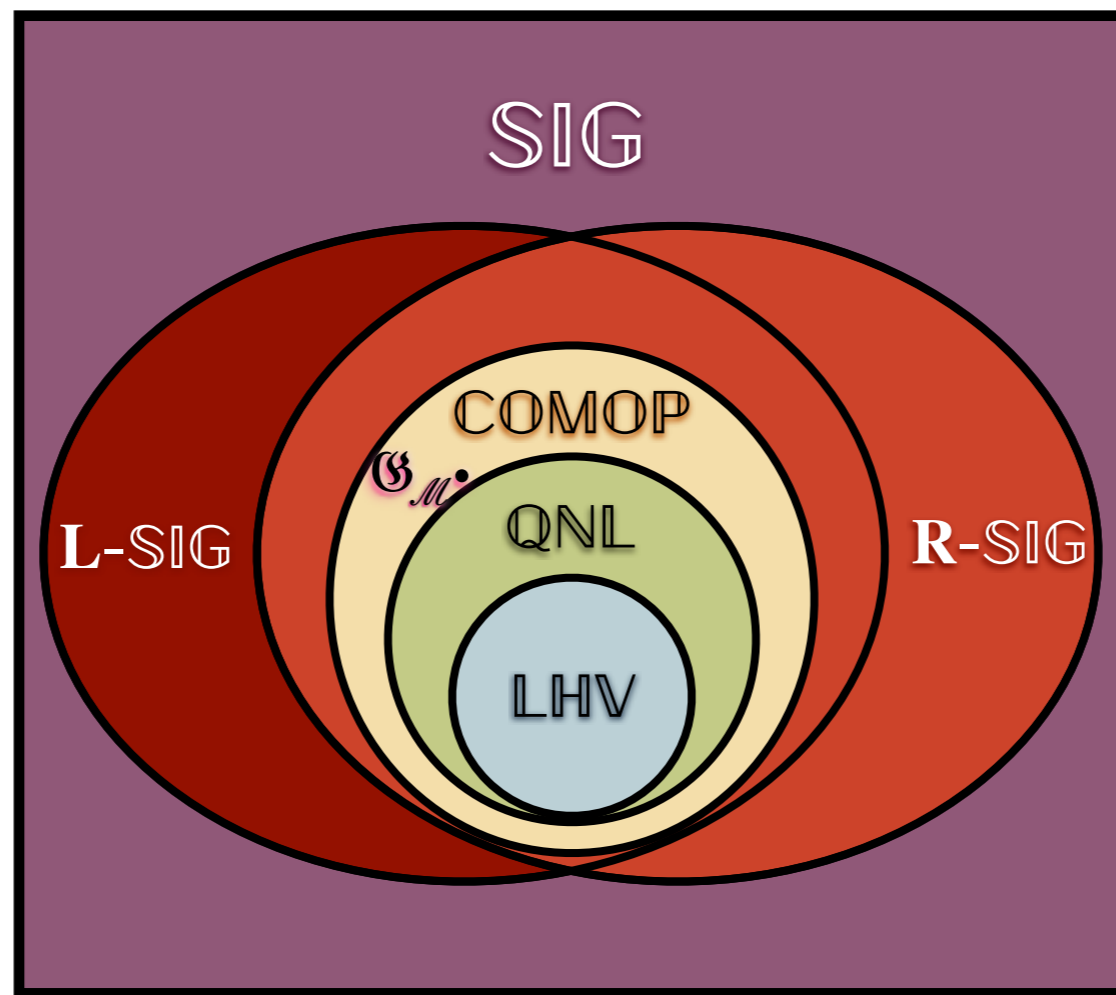

Note: \mathcal{G}_M is over infinite A,B

NON-LOCALITY HIERARCHY

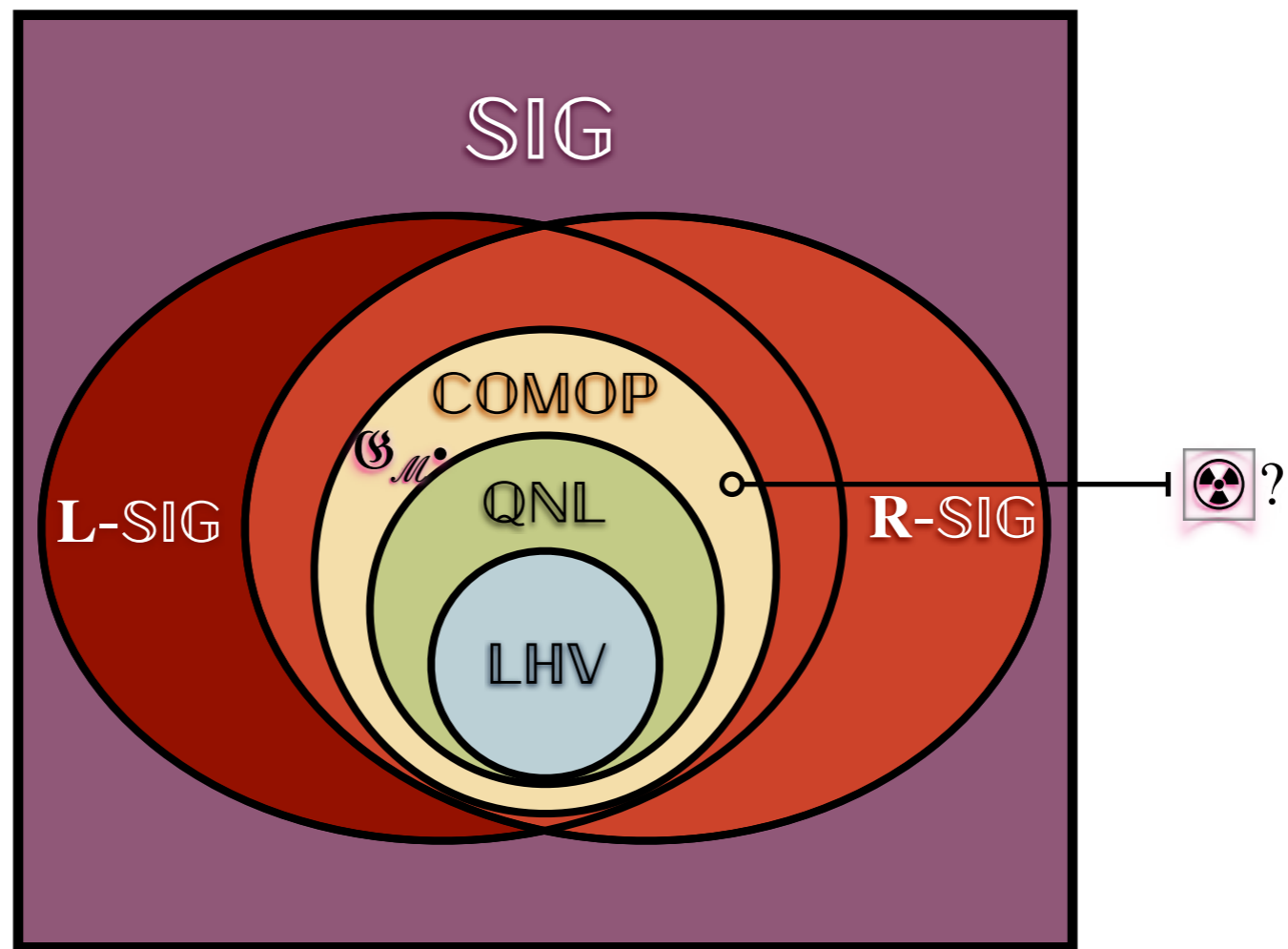

Note: \mathcal{G}_M is over infinite A,B

NON-LOCALITY HIERARCHY

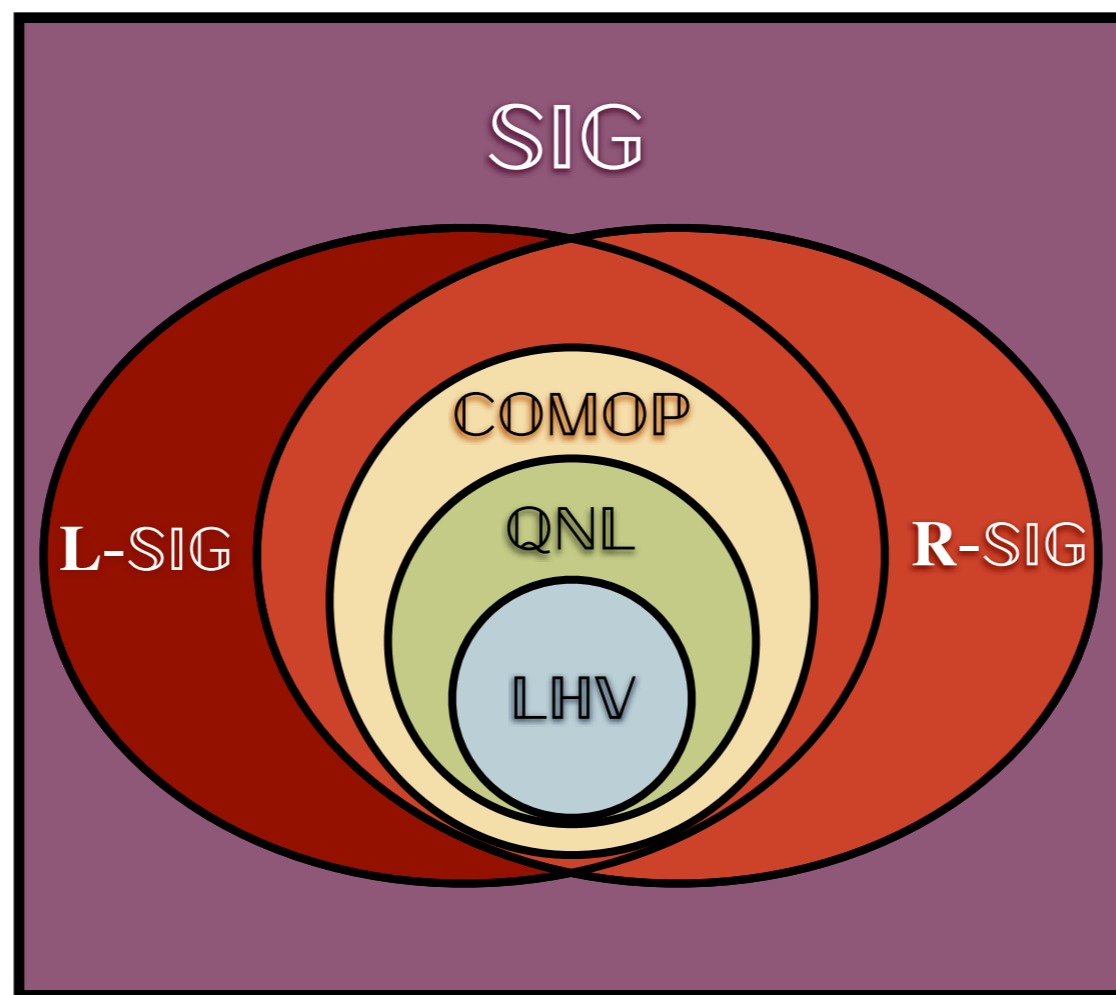

NON-LOCALITY HIERARCHY

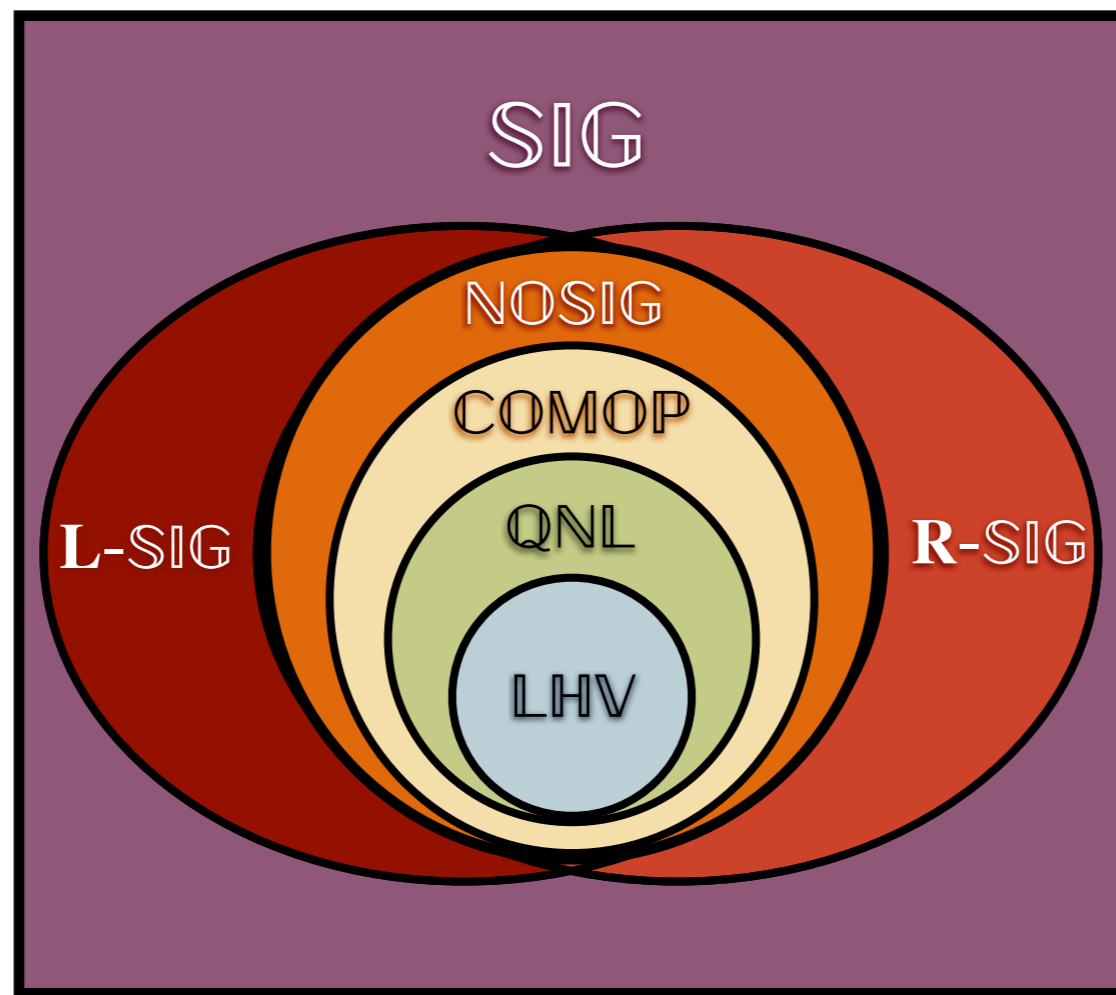

NON-LOCALITY HIERARCHY

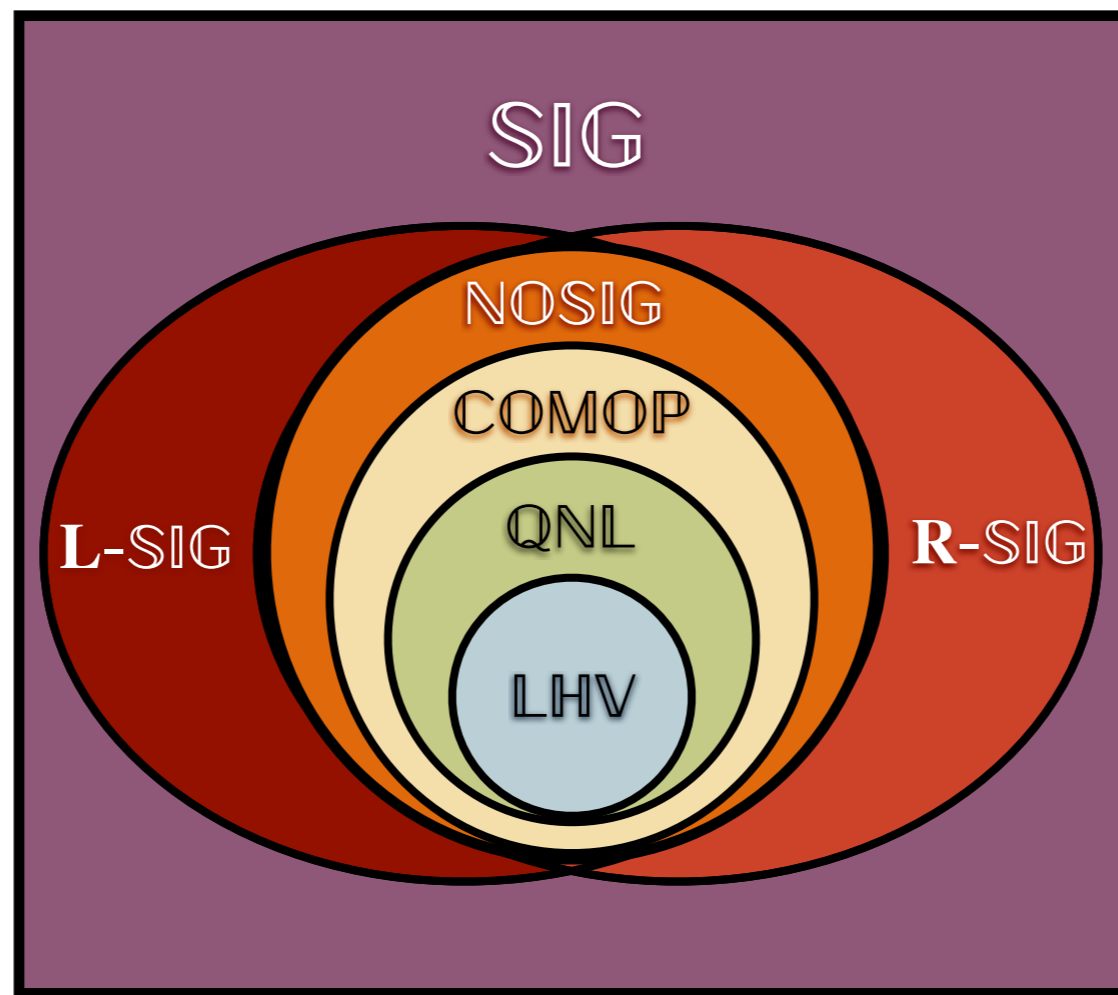

$$\text{2-party NOSIG} = \mathbf{L-SIG} \cap \mathbf{R-SIG}$$

NON-LOCALITY HIERARCHY

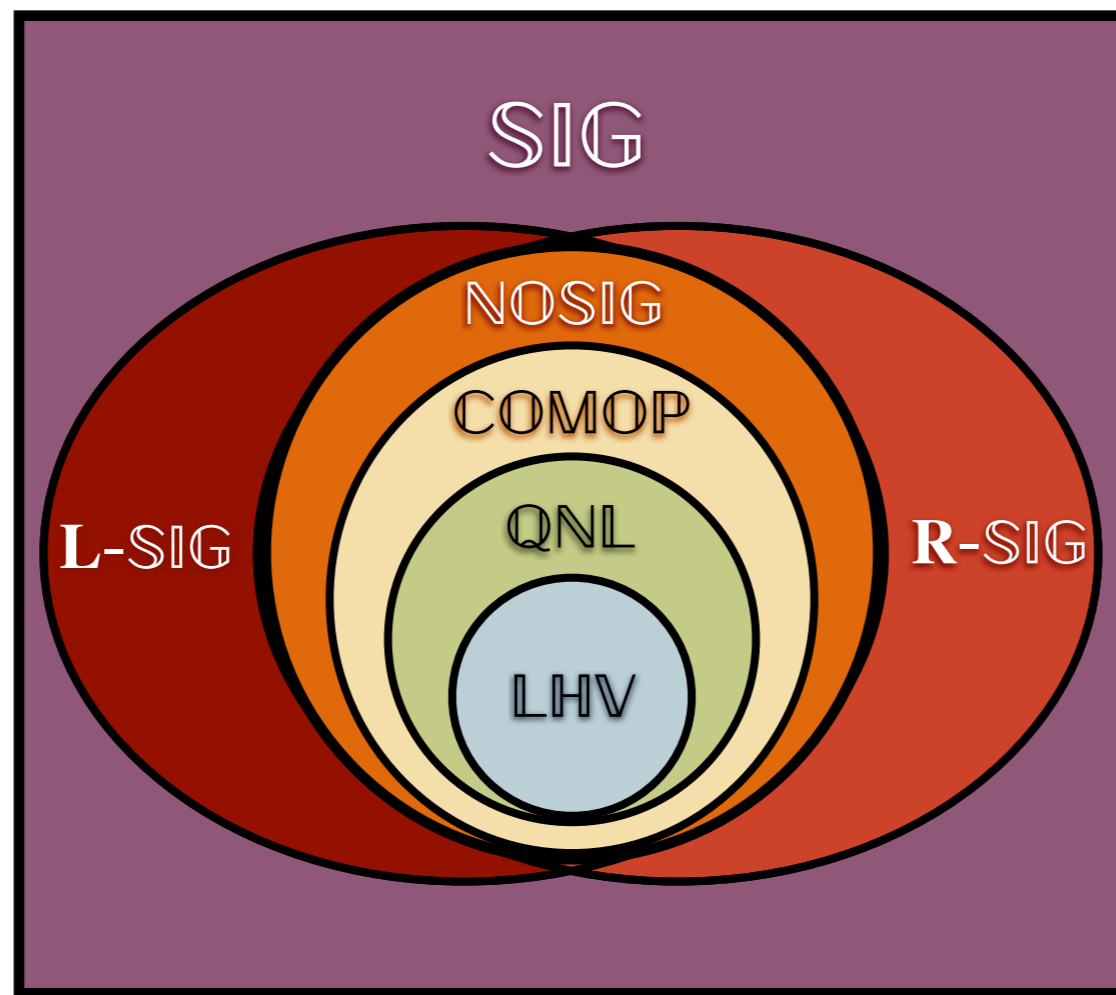

NON-LOCALITY HIERARCHY

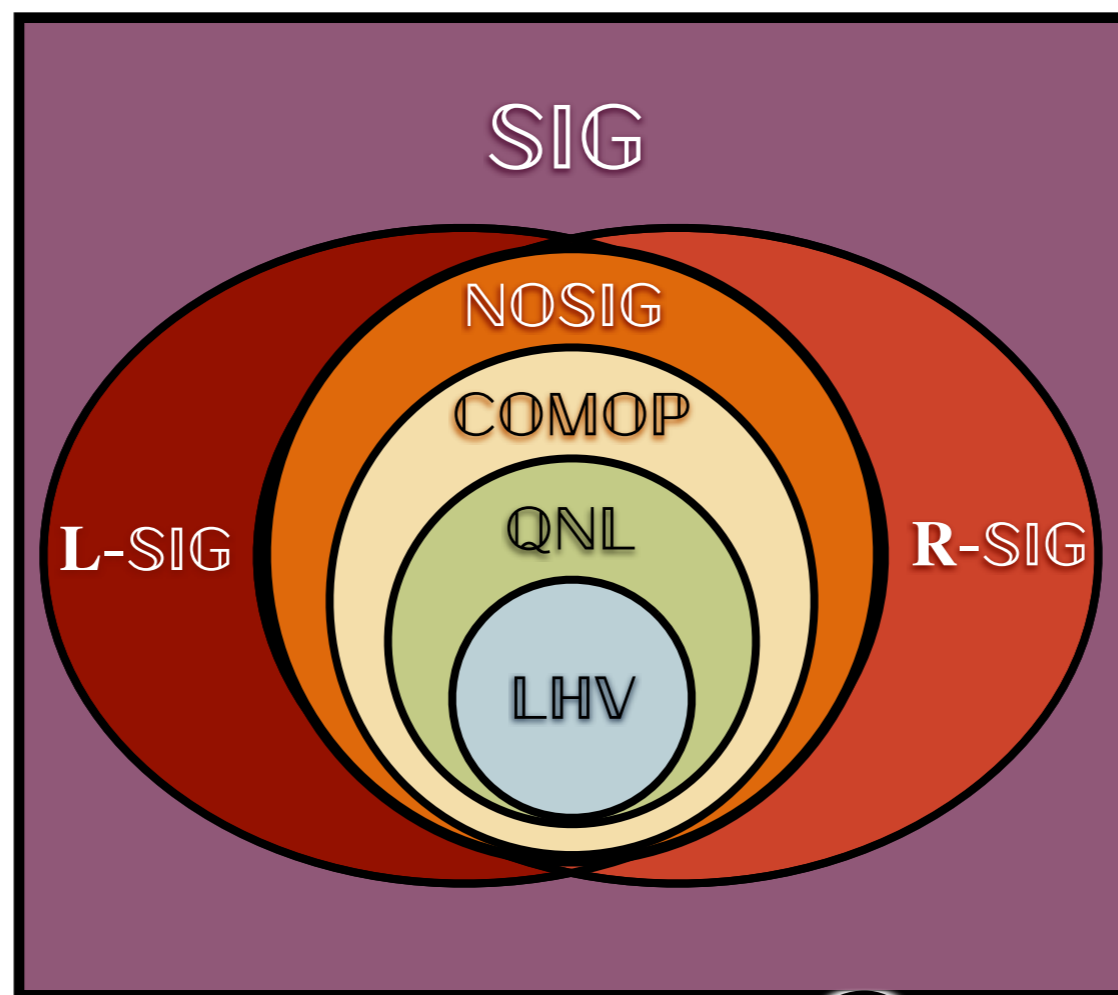

$$\text{N-party NOSIG} = \bigcap_{\pi} \pi\text{-SIG}$$

NON-LOCALITY HIERARCHY

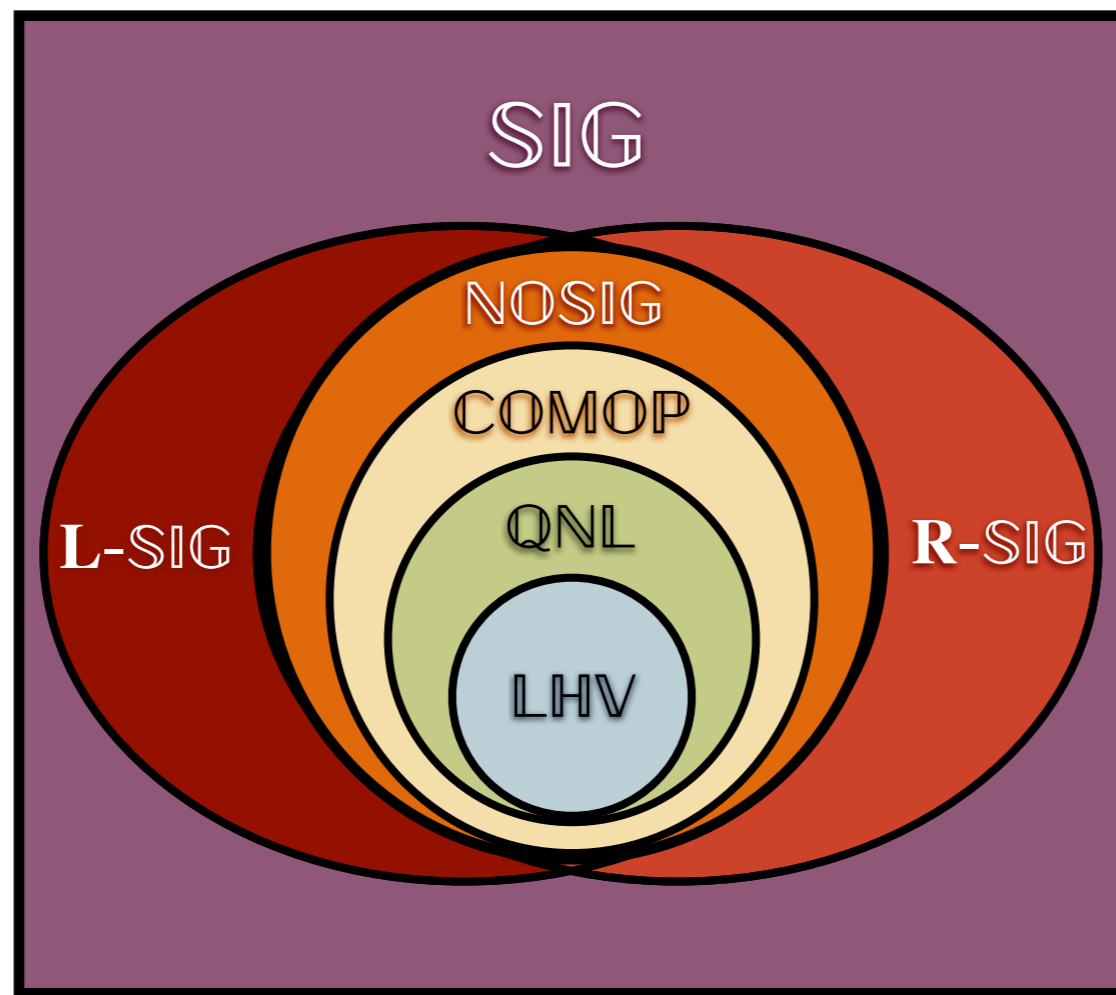

NON-LOCALITY HIERARCHY

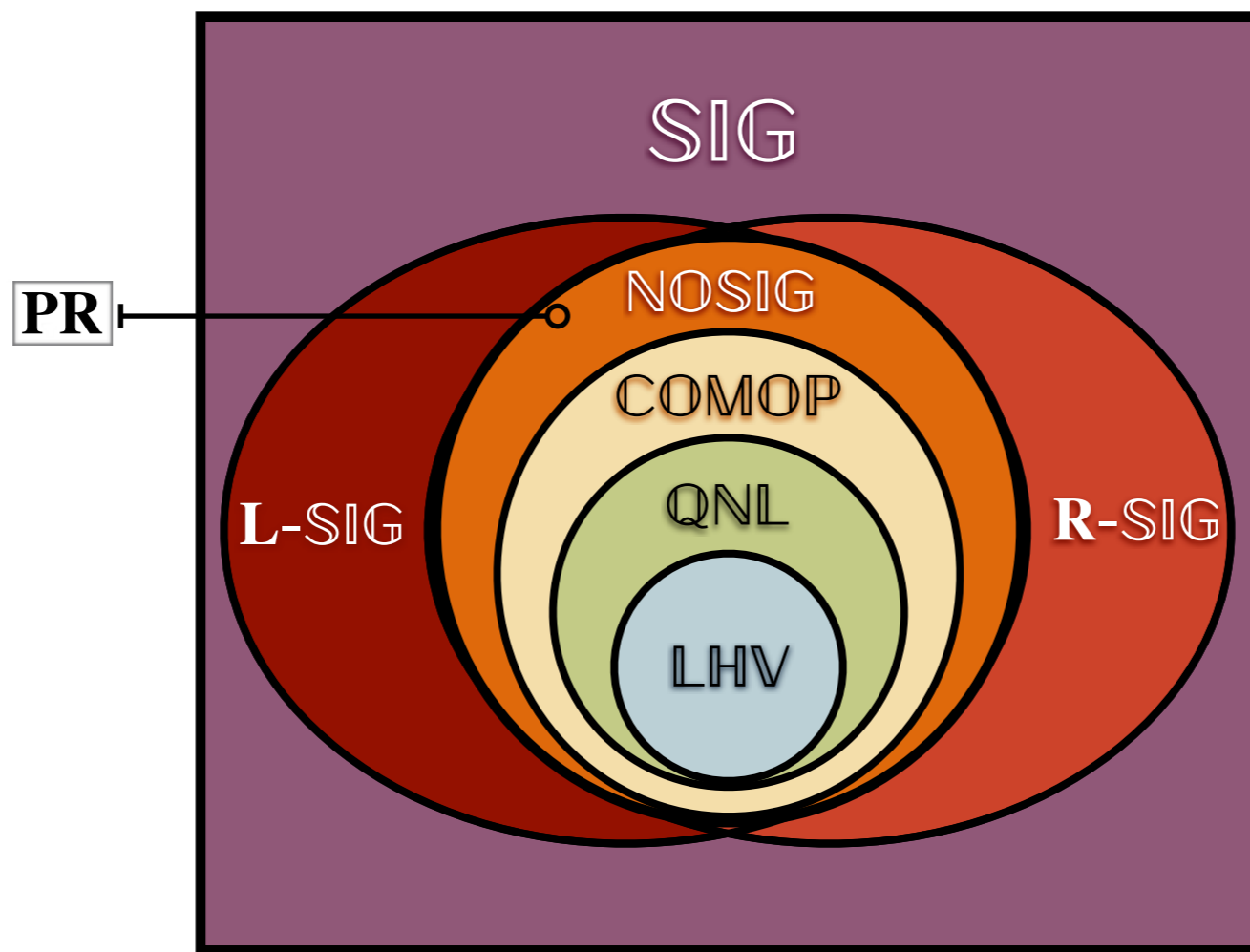

NON-LOCALITY HIERARCHY

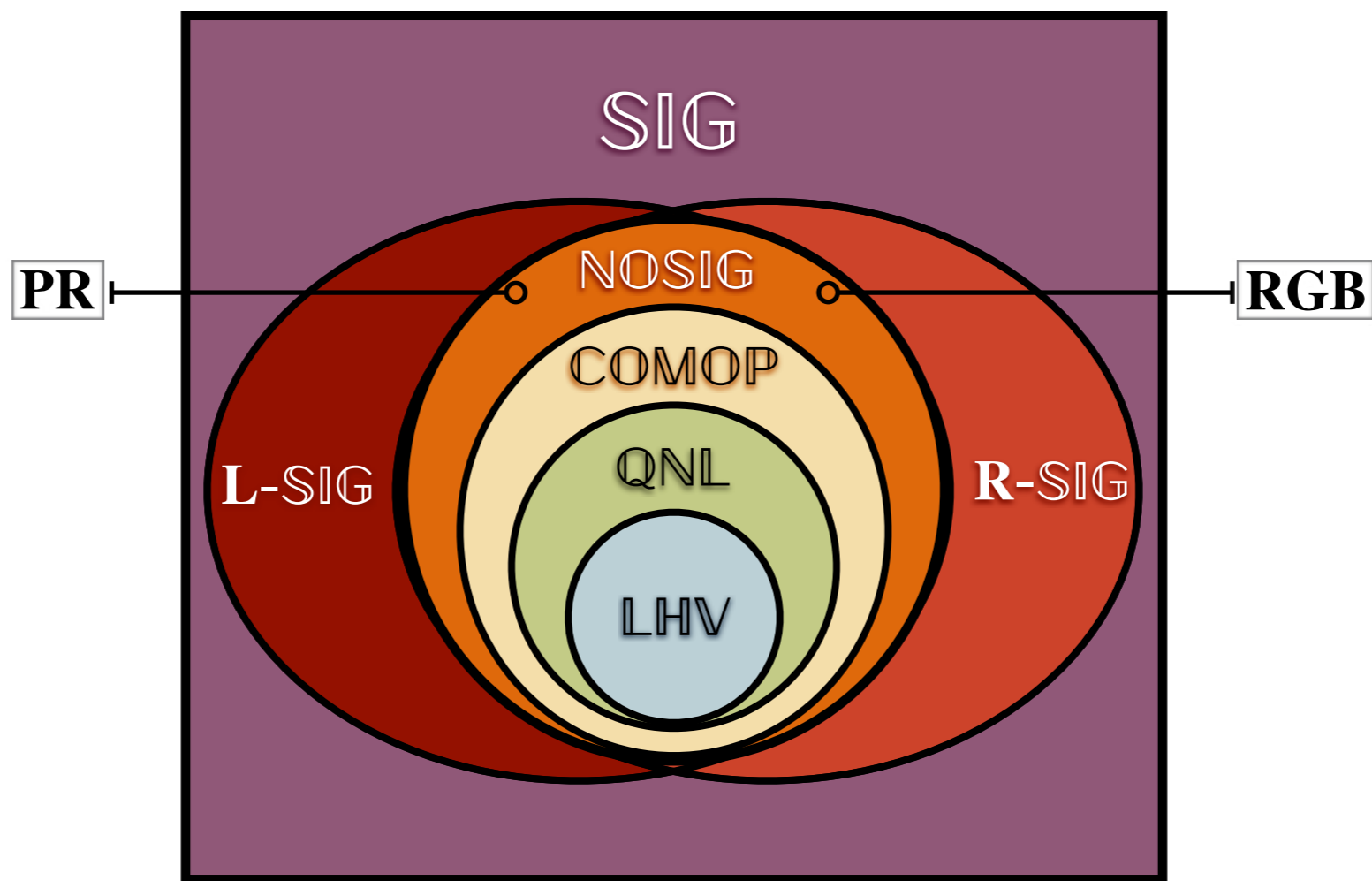

NON-LOCALITY HIERARCHY

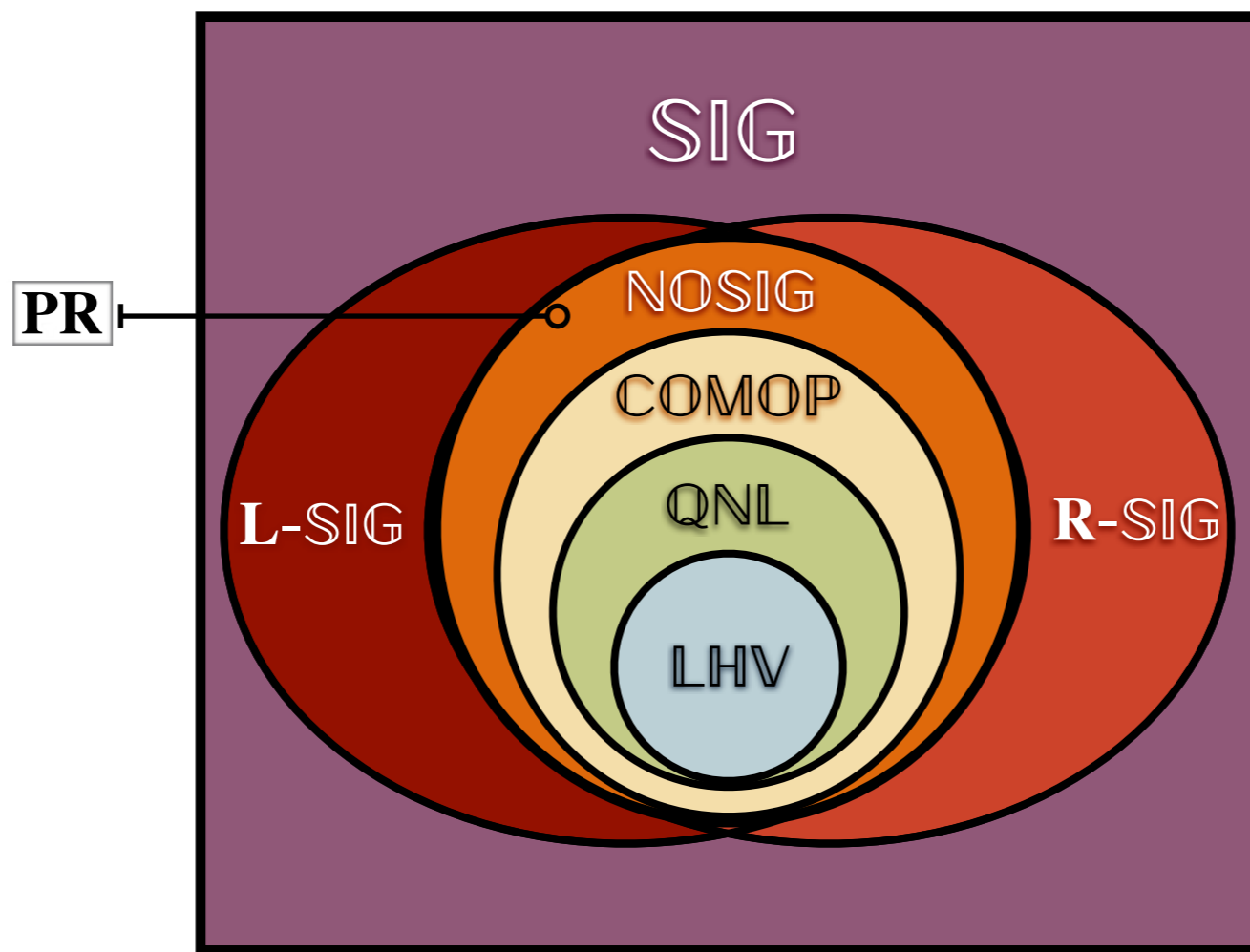

NON-LOCALITY HIERARCHY

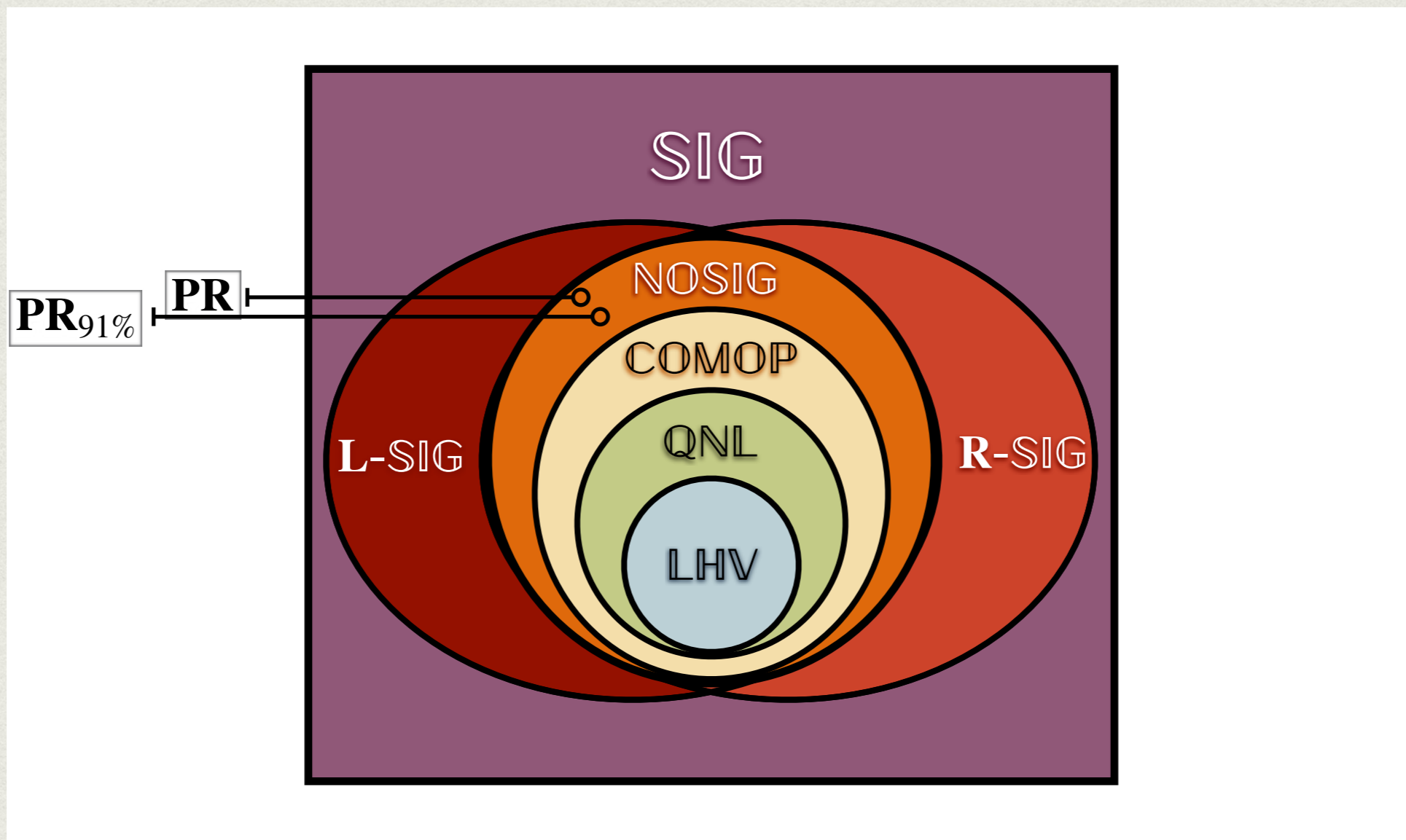

NON-LOCALITY HIERARCHY

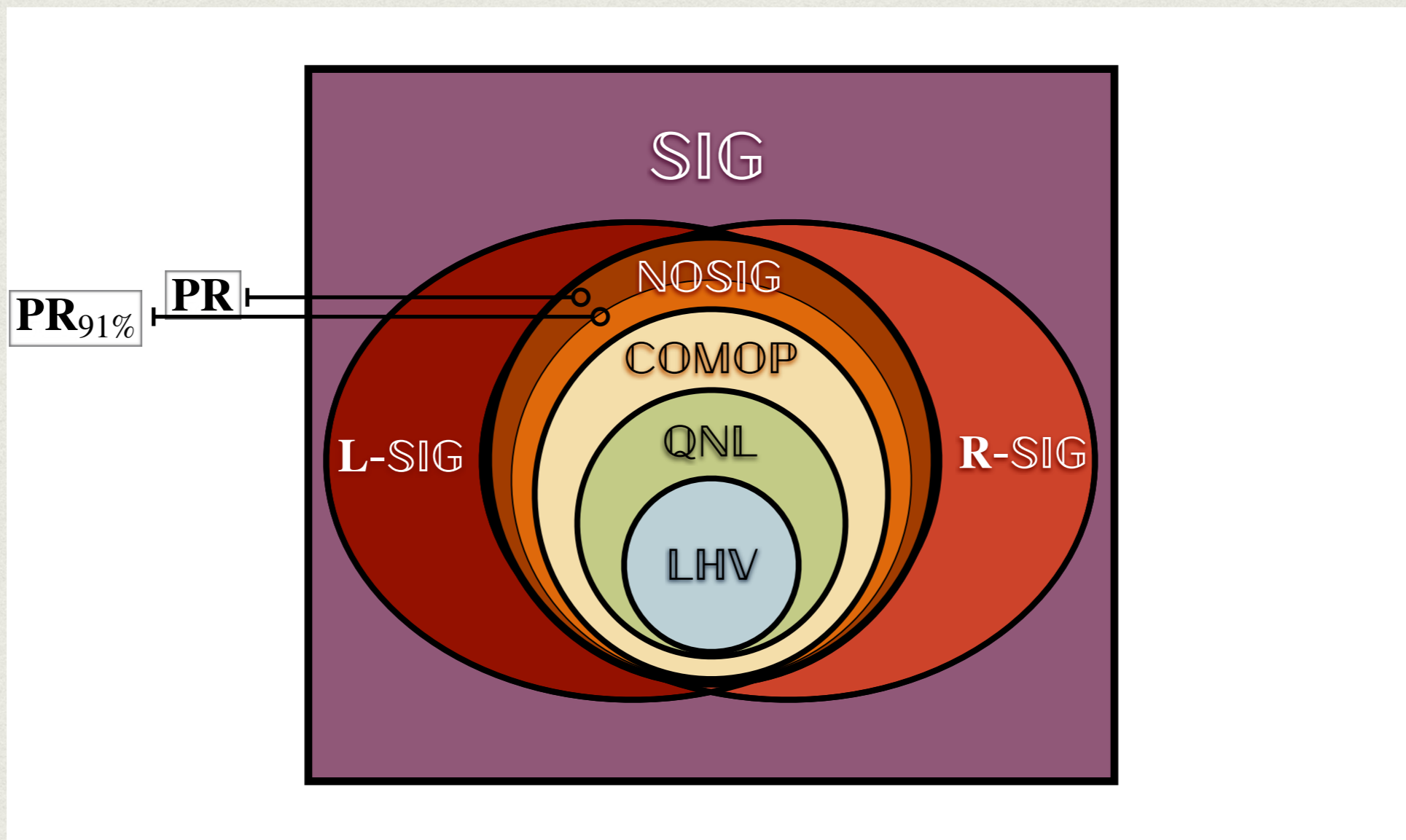

NON-LOCALITY HIERARCHY

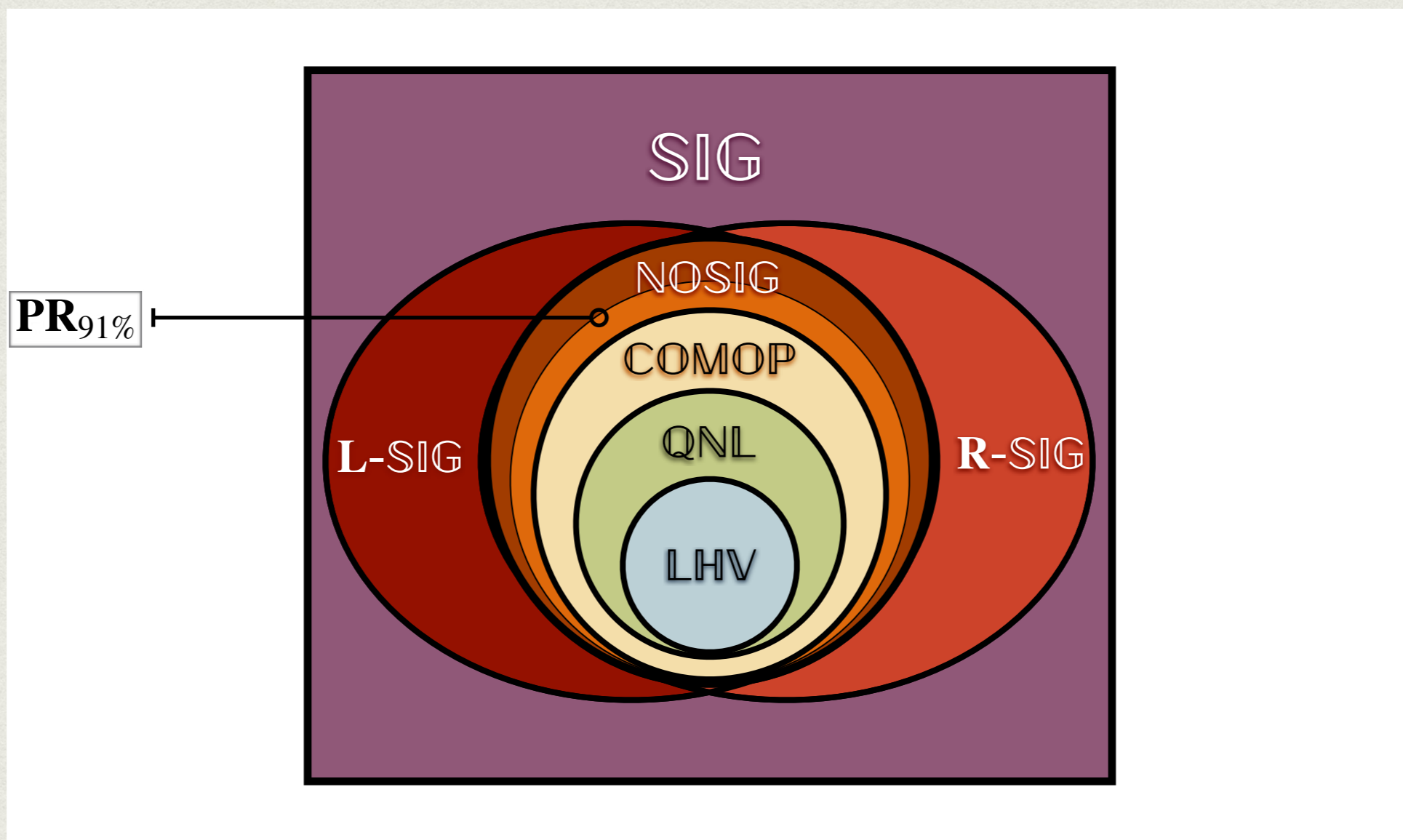

NON-LOCALITY HIERARCHY

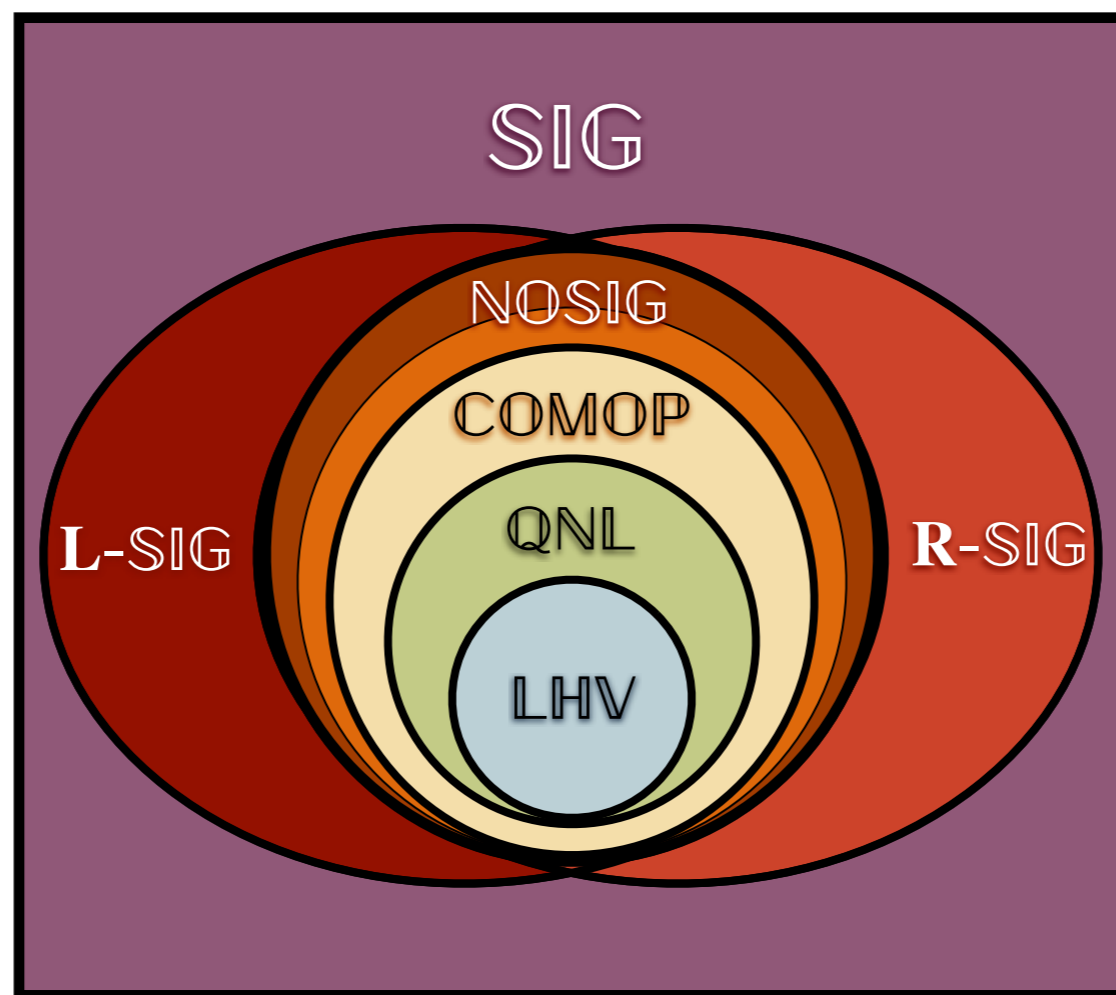

NON-LOCALITY HIERARCHY

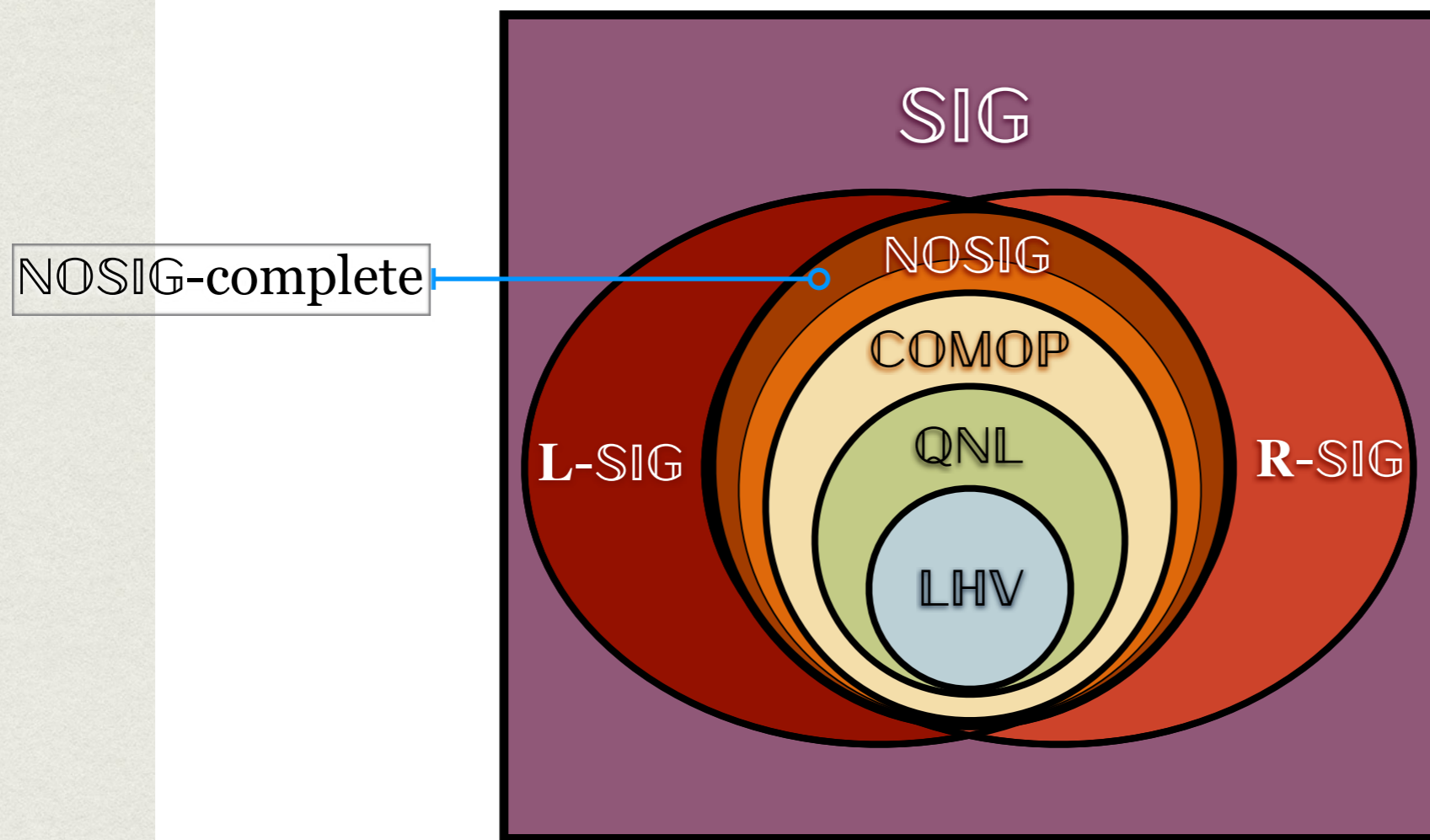

NON-LOCALITY HIERARCHY

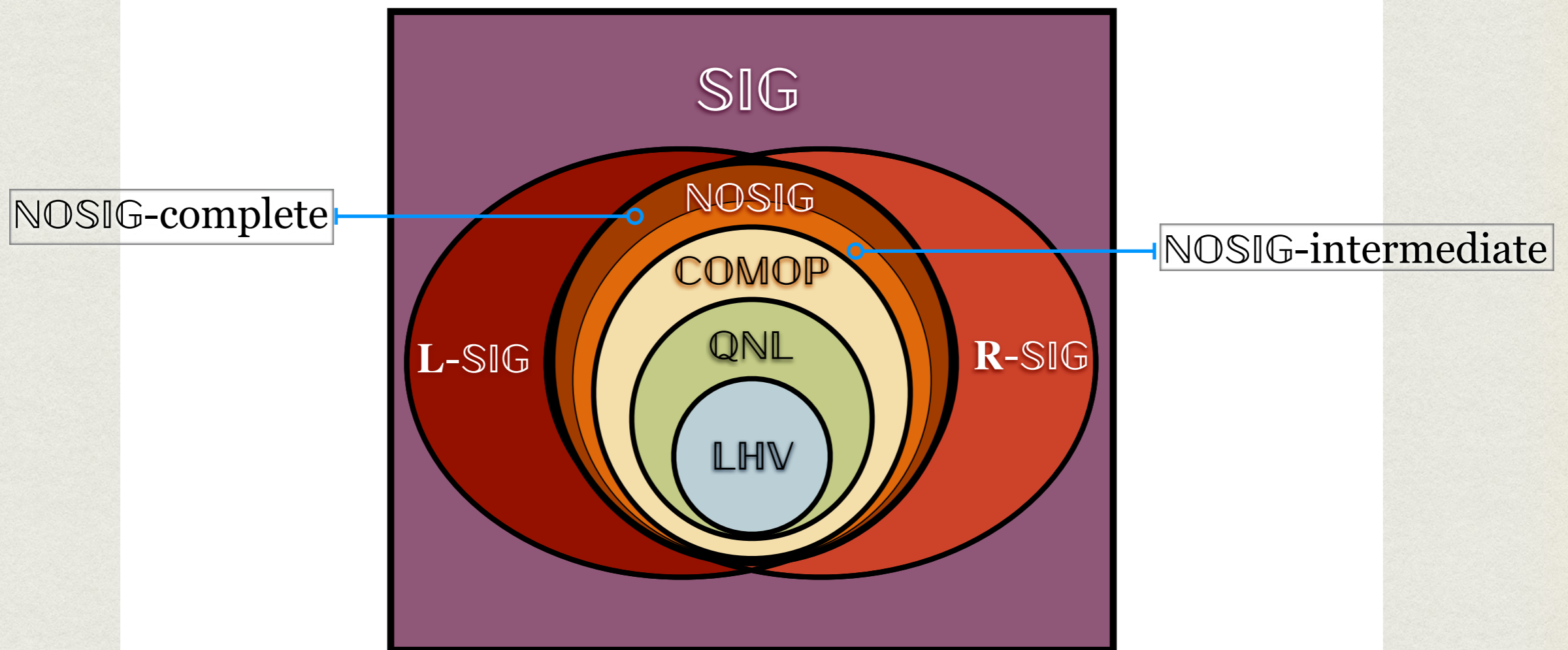

NON-LOCALITY HIERARCHY

At speeds greater than c

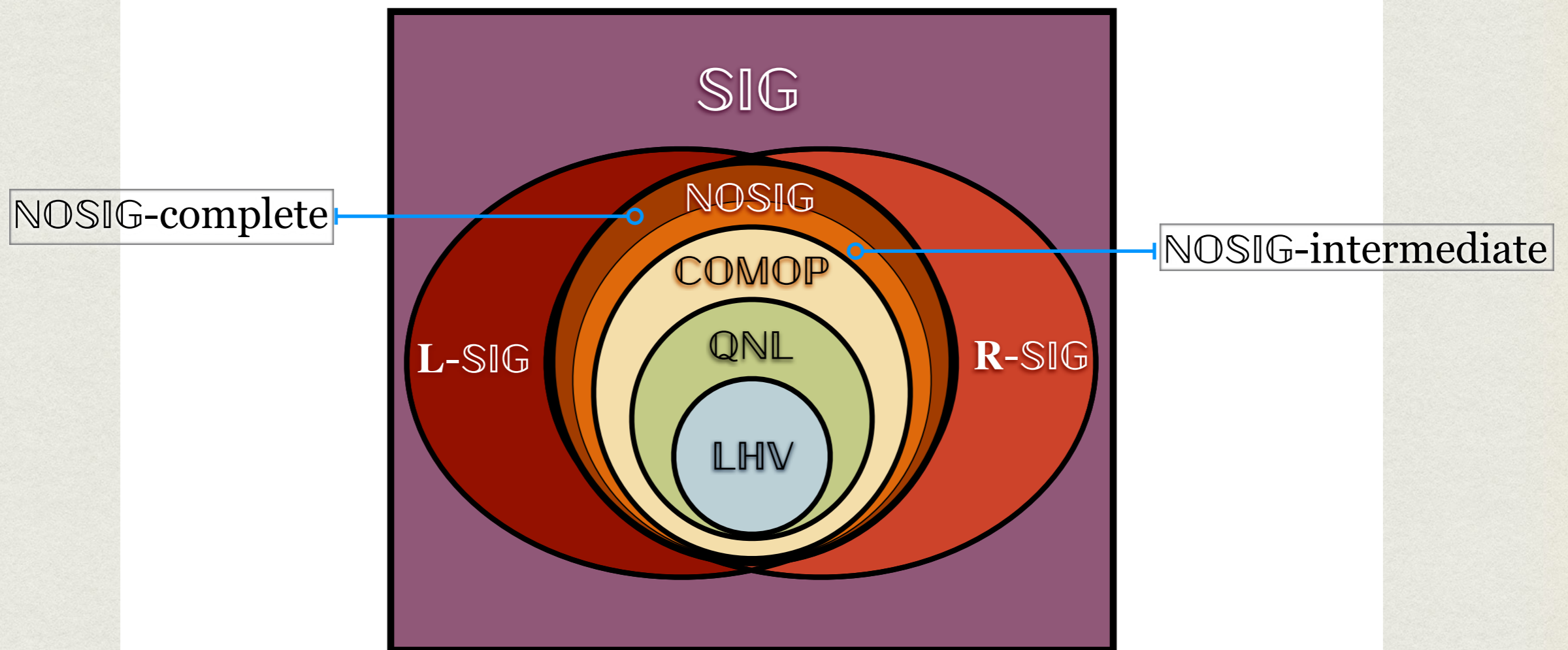

NON-LOCALITY HIERARCHY

At speeds greater than c

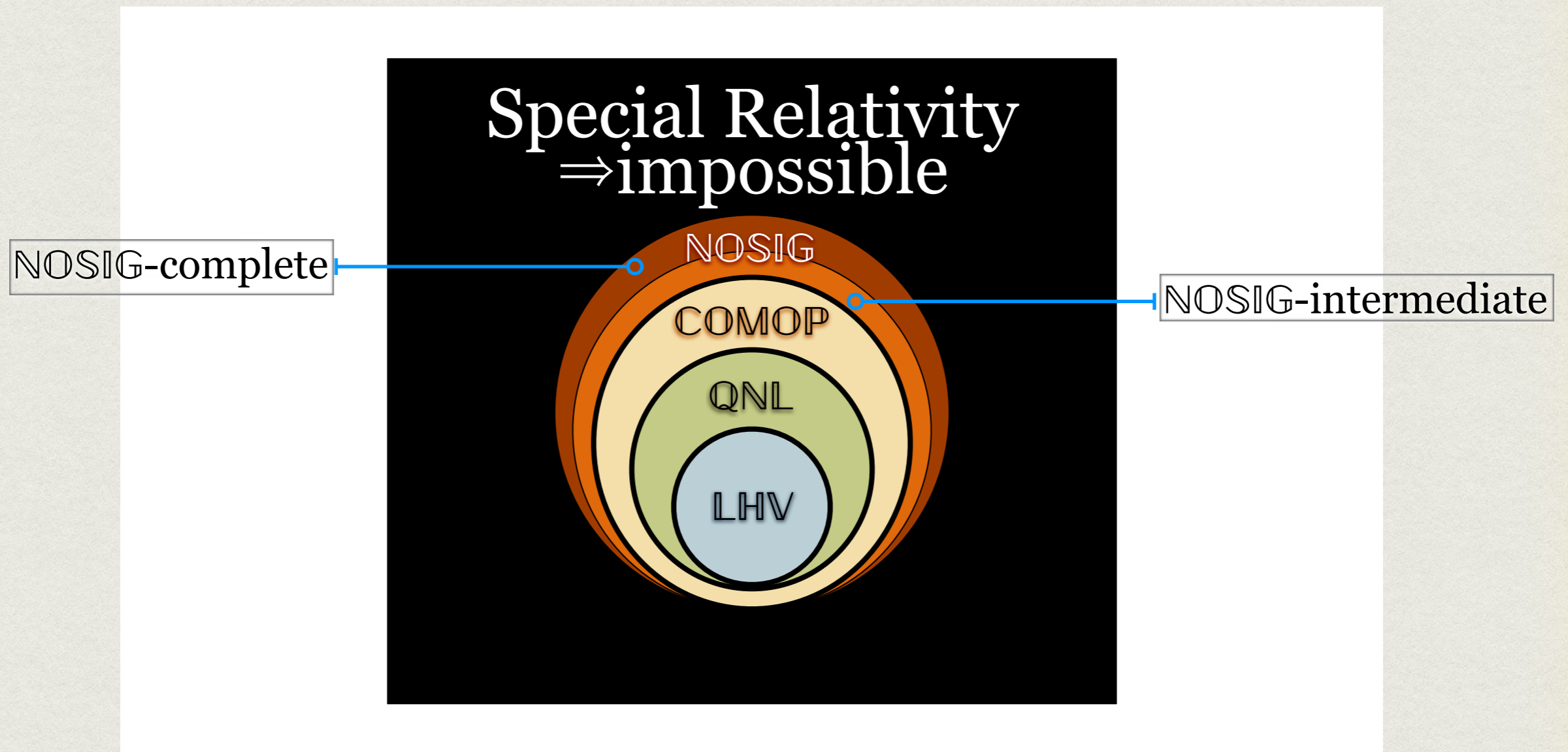

NON-LOCALITY HIERARCHY

At speeds greater than c

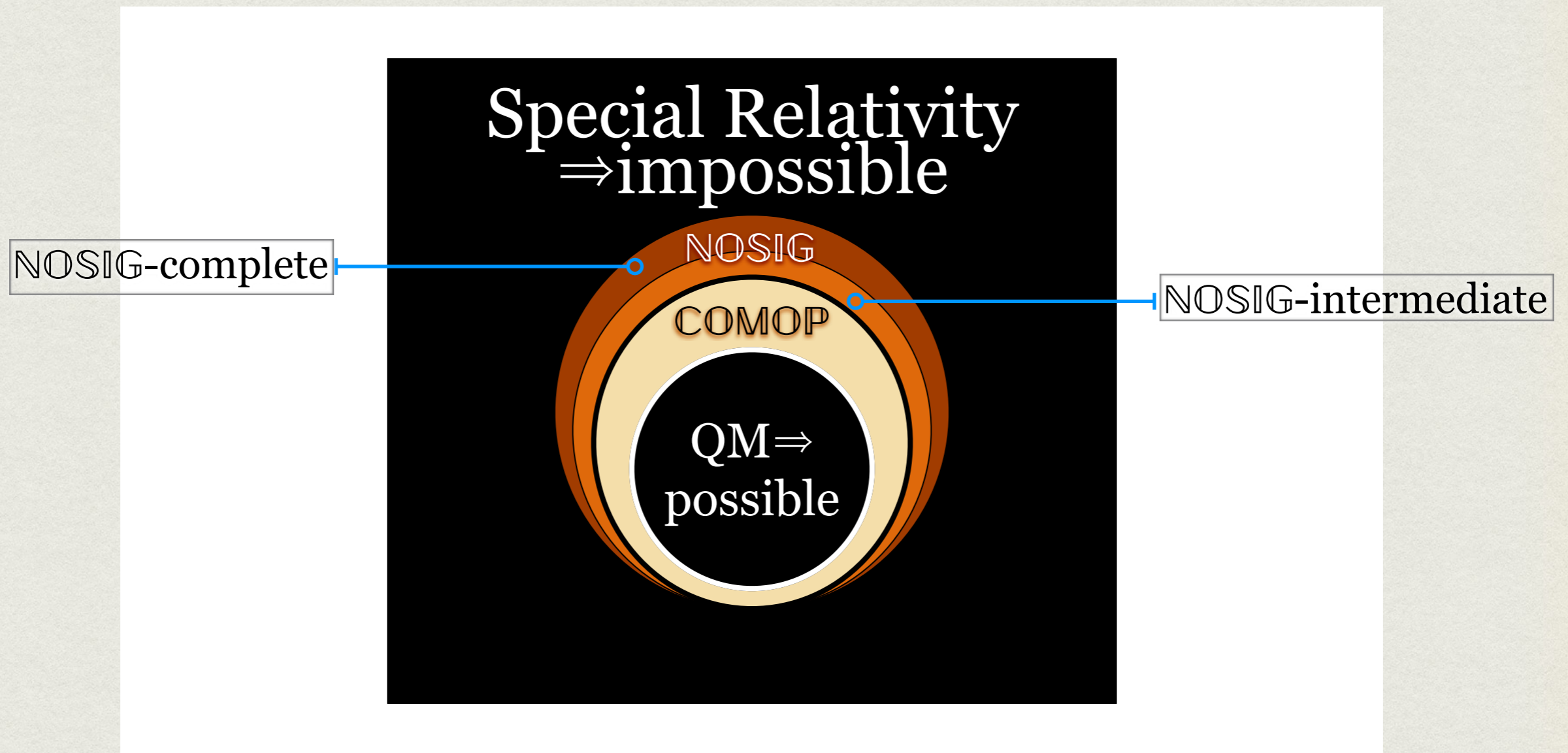

NON-LOCALITY HIERARCHY

At speeds greater than c

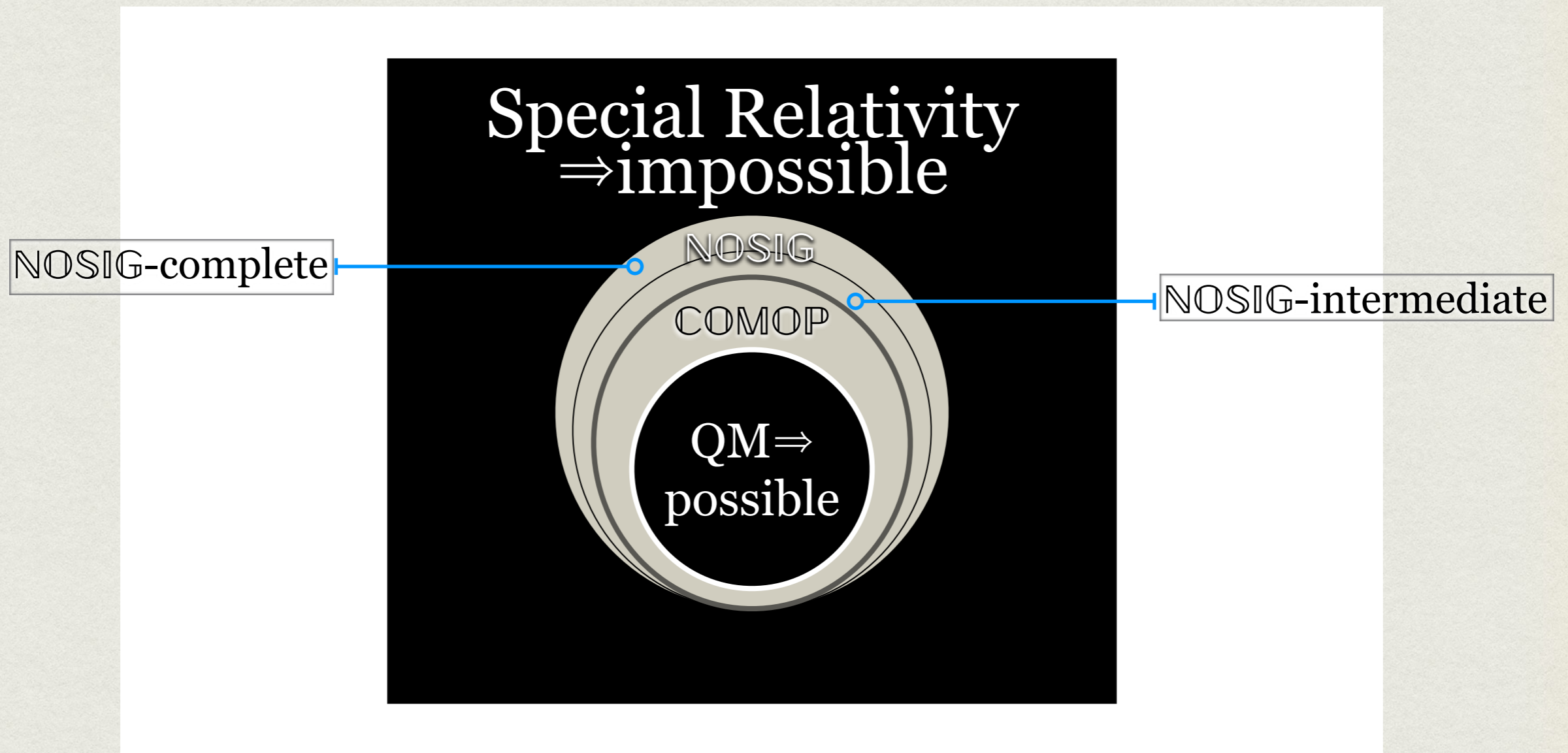

NON-LOCALITY HIERARCHY

At speeds greater than c

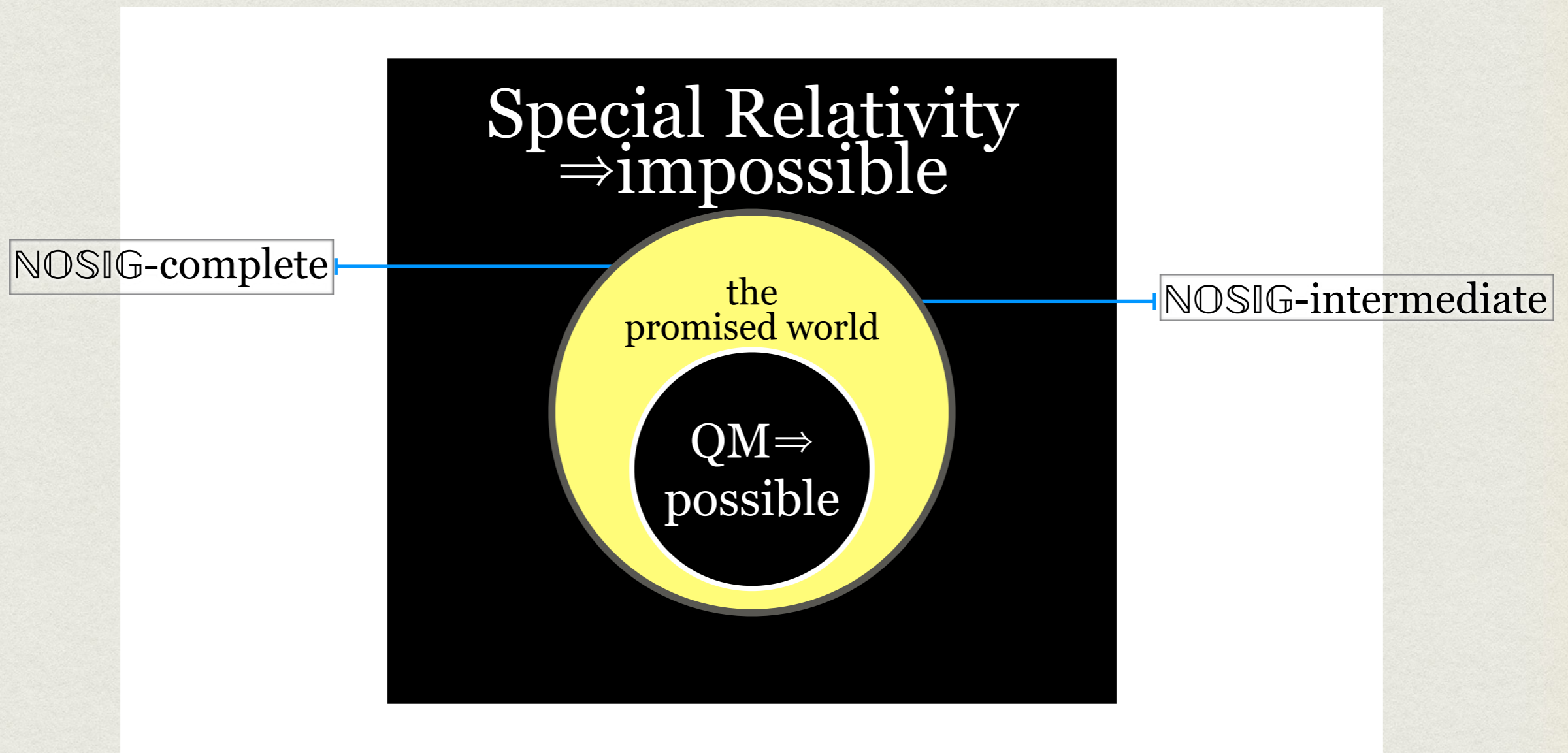

NON-LOCALITY HIERARCHY

At speeds greater than c

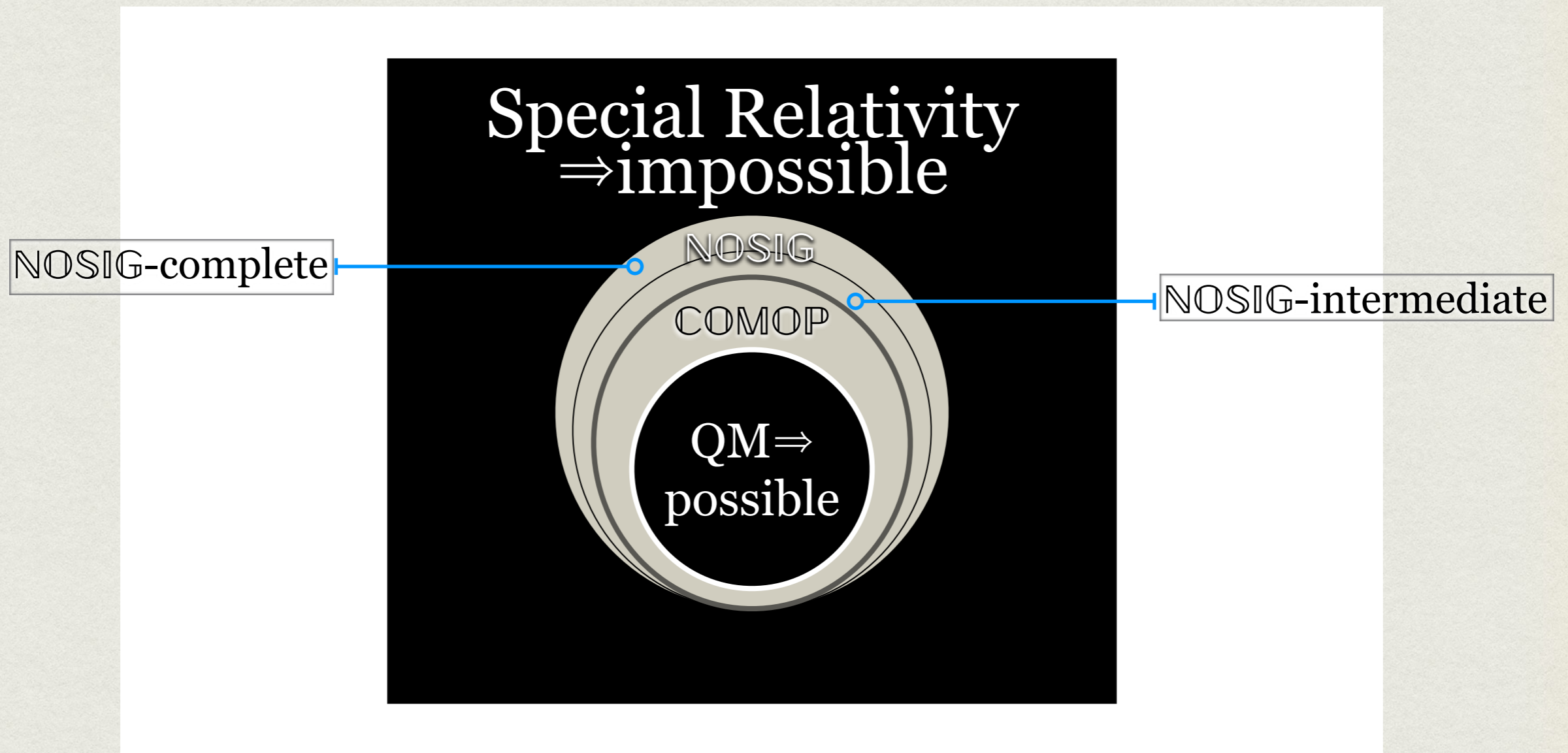

NON-LOCALITY HIERARCHY

At speeds greater than c

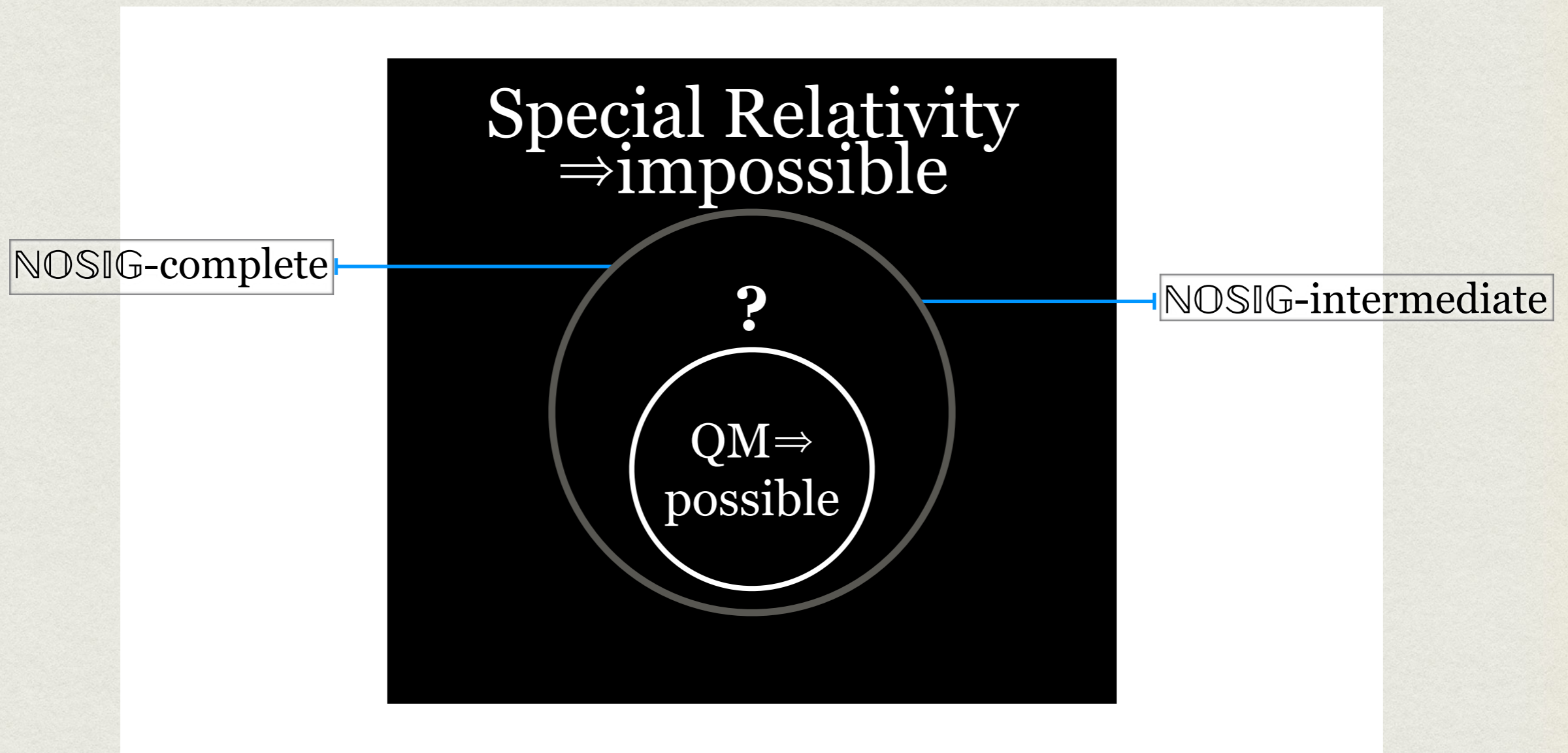

NON-LOCALITY HIERARCHY

At speeds greater than c

***Very* Special Relativity
 \Rightarrow impossible**

NOSIG-complete

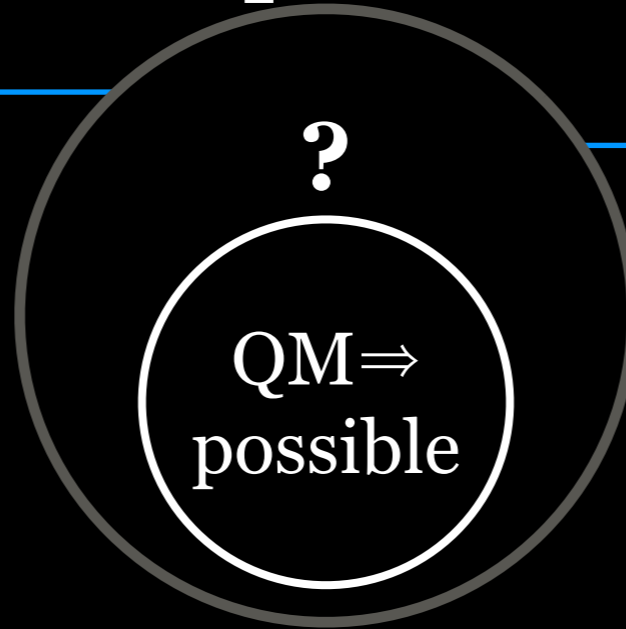

NOSIG-intermediate

NON-LOCALITY HIERARCHY

At speeds greater than c

***Very* Special Relativity
 \Rightarrow impossible**

NOSIG-complete

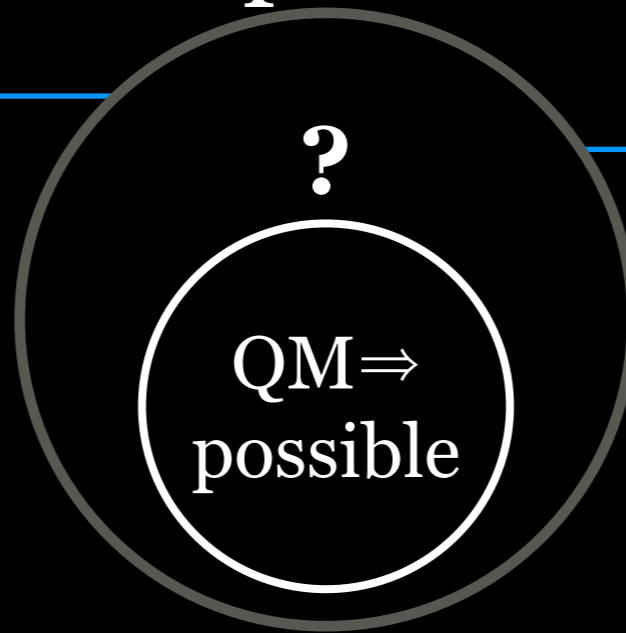

NOSIG-intermediate

**VSR1 : no correlation beyond QNL can be
achieved faster than speed c**

NON-LOCALITY HIERARCHY

At speeds greater than c

***Very* Special Relativity
 \Rightarrow impossible**

NOSIG-complete

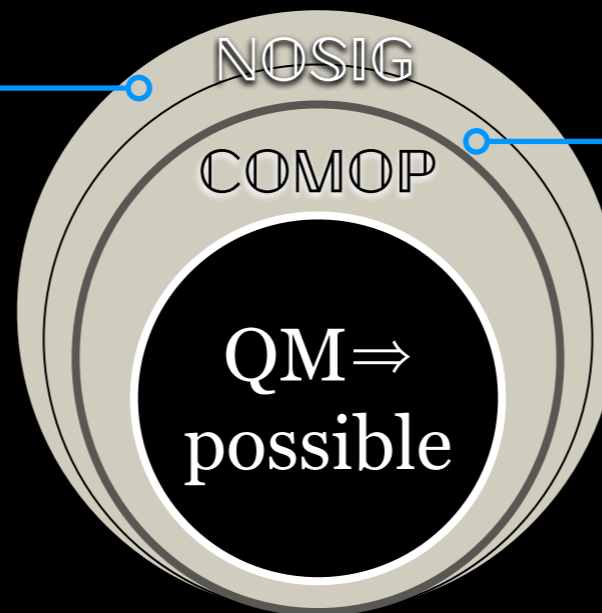

NOSIG-intermediate

**VSR1 : no correlation beyond QNL can be
achieved faster than speed c**

NON-LOCALITY HIERARCHY

At speeds greater than c

***Very* Special Relativity
 \Rightarrow impossible**

NOSIG-complete

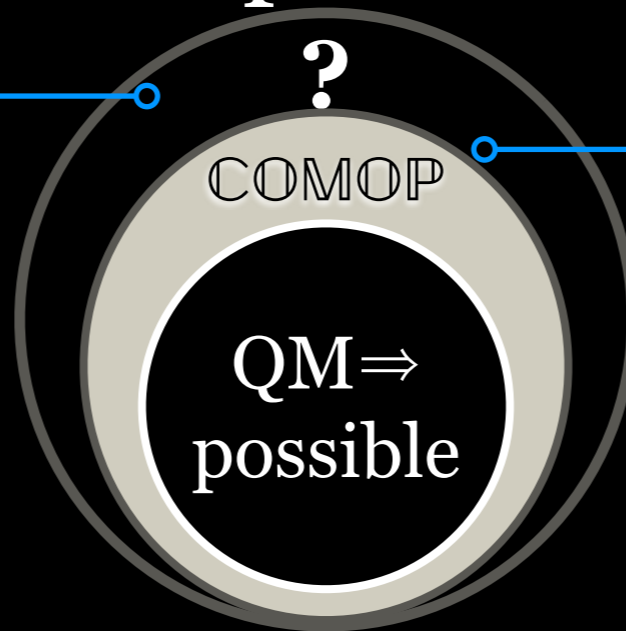

NOSIG-intermediate

**VSR1 : no correlation beyond QNL can be
achieved faster than speed c**

NON-LOCALITY HIERARCHY

At speeds greater than c

***Very* Special Relativity
 \Rightarrow impossible**

NOSIG-complete

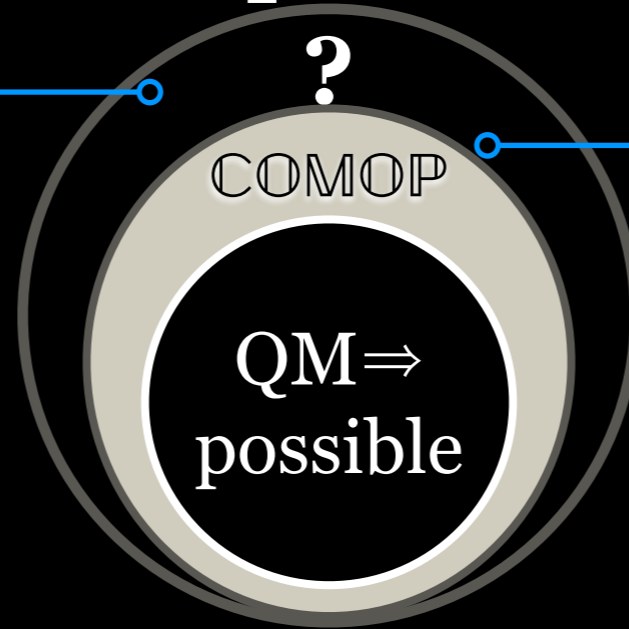

NOSIG-intermediate

**VSR2 : no correlation beyond COMOP can be
achieved faster than speed c**

NON-LOCALITY HIERARCHY

At speeds greater than c

***Very* Special Relativity
⇒ impossible**

NOSIG-complete

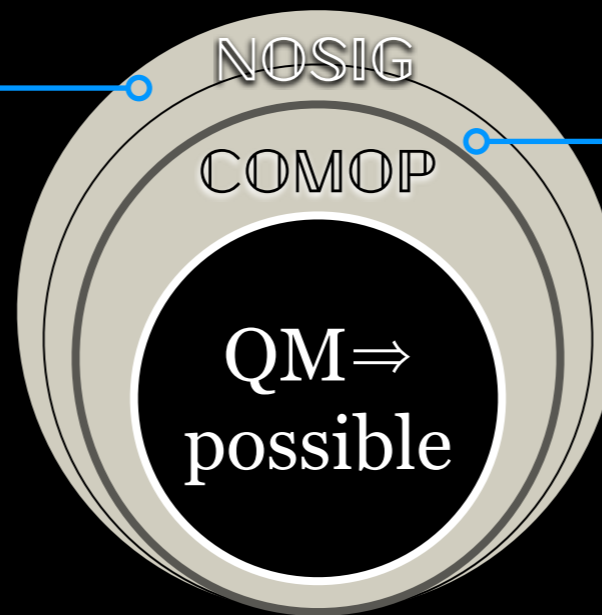

NOSIG-intermediate

**VSR2 : no correlation beyond COMOP can be
achieved faster than speed c**

NON-LOCALITY HIERARCHY

At speeds greater than c

***Very* Special Relativity
 \Rightarrow impossible**

NOSIG-complete

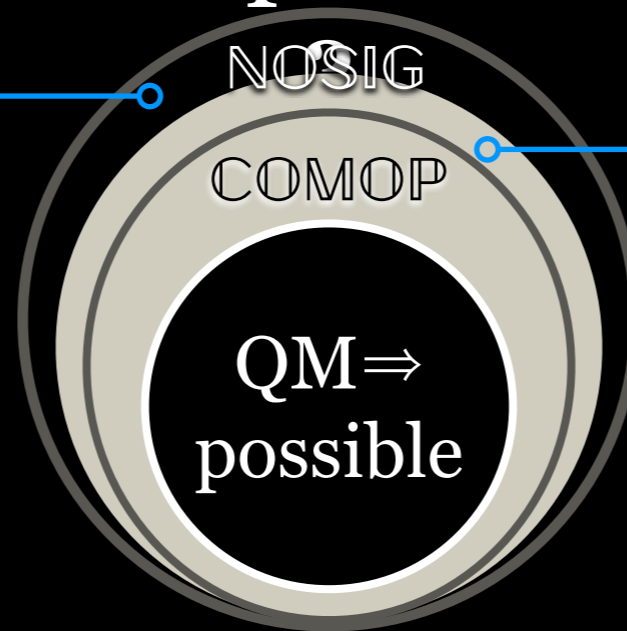

NOSIG-intermediate

**VSR2 : no correlation beyond COMOP can be
achieved faster than speed c**

NON-LOCALITY HIERARCHY

At speeds greater than c

***Very* Special Relativity
 \Rightarrow impossible**

NOSIG-complete

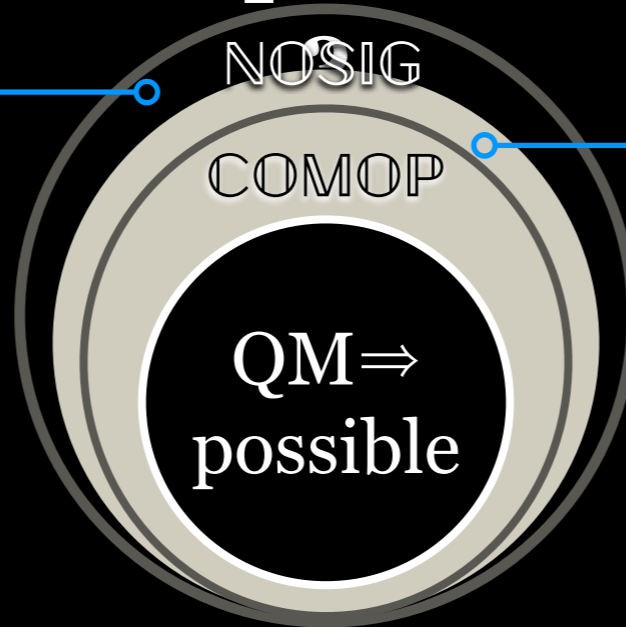

NOSIG-intermediate

**VSR₃ : no correlation that is NOSIG-complete
can be achieved faster than speed c**

NON-LOCALITY HIERARCHY

At speeds greater than c

***Very* Special Relativity
⇒ impossible**

NOSIG-complete

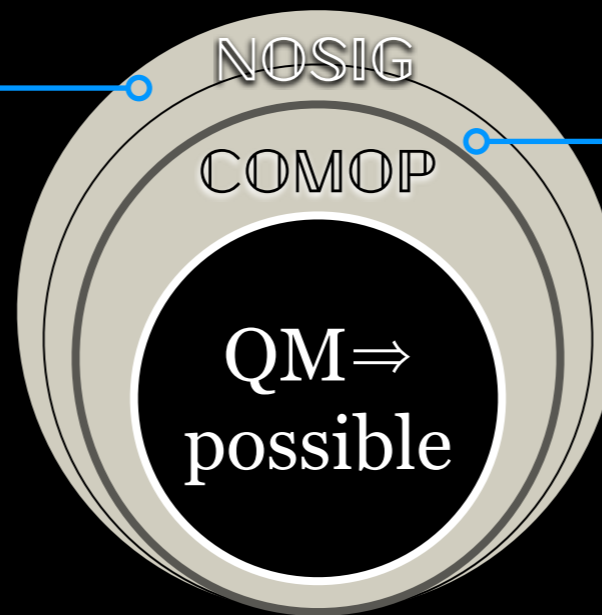

NOSIG-intermediate

**VSR₃ : no correlation that is NOSIG-complete
can be achieved faster than speed c**

NON-LOCALITY HIERARCHY

At speeds greater than c

***Very* Special Relativity
⇒ impossible**

NOSIG-complete

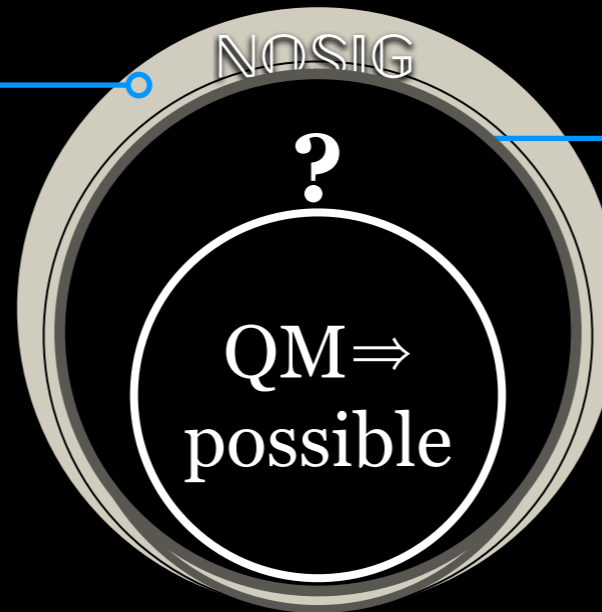

NOSIG-intermediate

QM+1/2/3 : some correlation beyond
QNL/COMOP/NOSIG-intermediate
can be achieved faster than speed c

NON-LOCALITY HIERARCHY

At speeds greater than c

***Very* Special Relativity
 \Rightarrow impossible**

NOSIG-complete

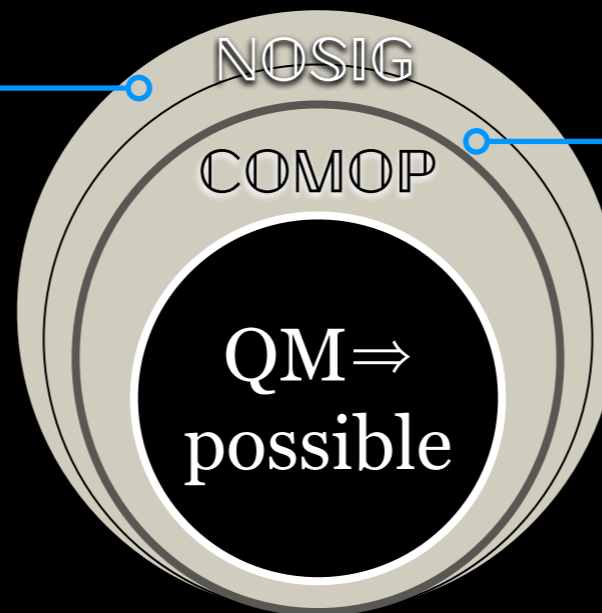

NOSIG-intermediate

QM+1/2/3 : some correlation beyond
QNL/COMOP/NOSIG-intermediate
can be achieved faster than speed c

TO DO LIST

VSR₁ : no correlation beyond QNL can be achieved faster than speed c

VSR₂ : no correlation beyond COMOP can be achieved faster than speed c

VSR₃ : no correlation that is NOSIG-complete can be achieved faster than speed c

QM+1: some correlation beyond QNL can be achieved faster than speed c

QM+2 : some correlation beyond COMOP can be achieved faster than speed c

QM+3 : all NOSIG correlations can be achieved faster than speed c



9th International Conference on
New Frontiers in Physics (ICNFP 2020)

A WHOLE WORLD LIES BETWEEN
QUANTUM NON-LOCALITY
AND COMMUNICATION

Claude Crépeau



McGill

NON-LOCALITY HIERARCHIES

NON-LOCALITY HIERARCHIES



NON-LOCALITY HIERARCHIES

SIG

LHV

NON-LOCALITY HIERARCHIES

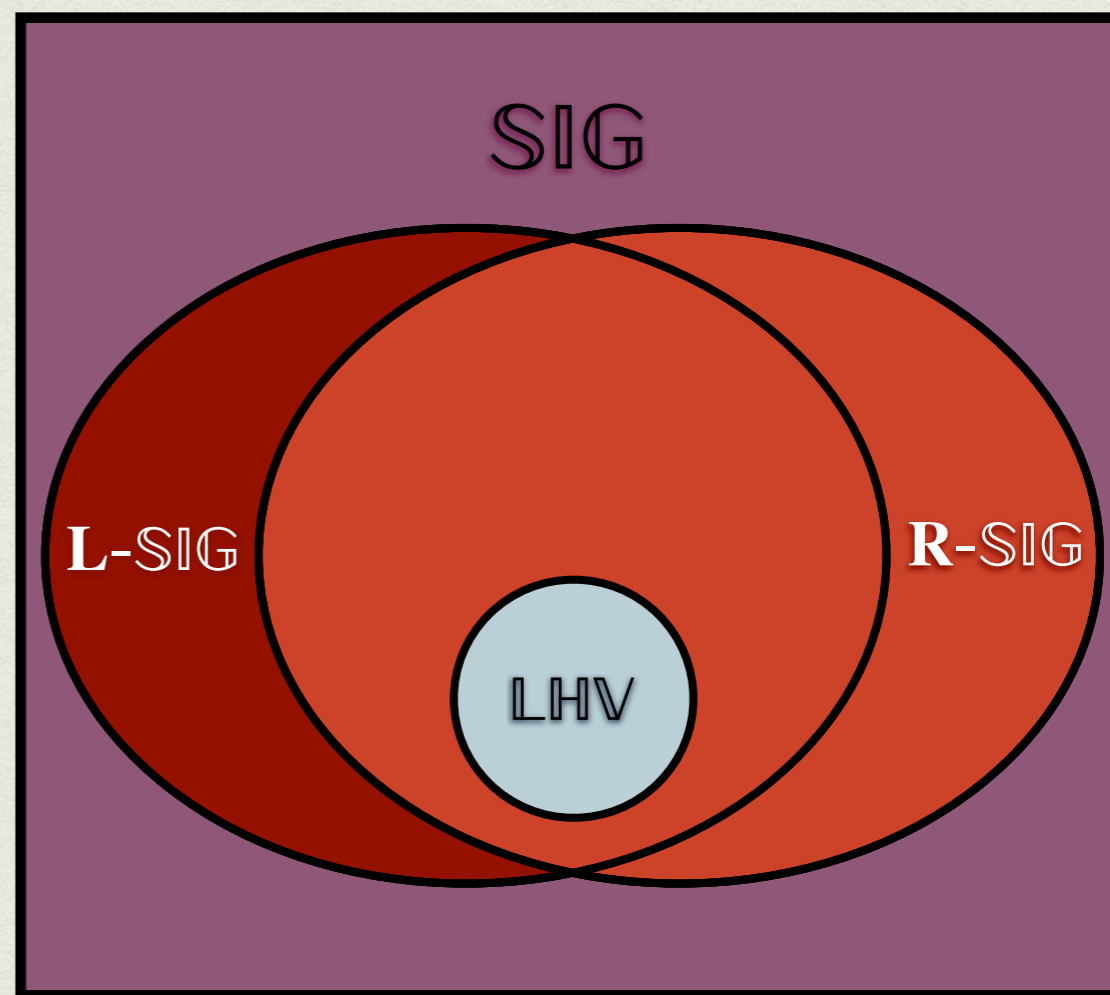

NON-LOCALITY HIERARCHIES

$|X\rangle = \text{Quantum analog of } X$

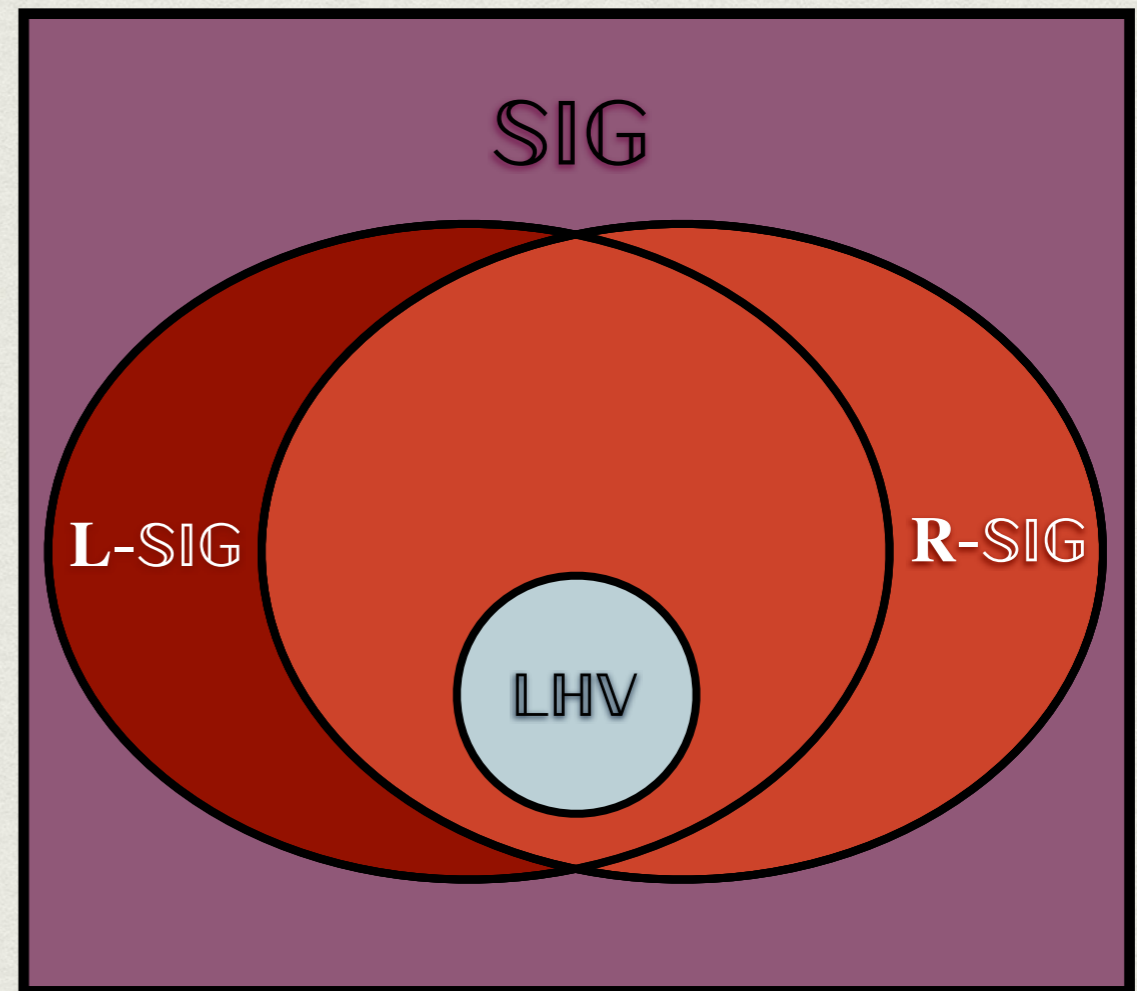

NON-LOCALITY HIERARCHIES

$|X\rangle = \text{Quantum analog of } X$

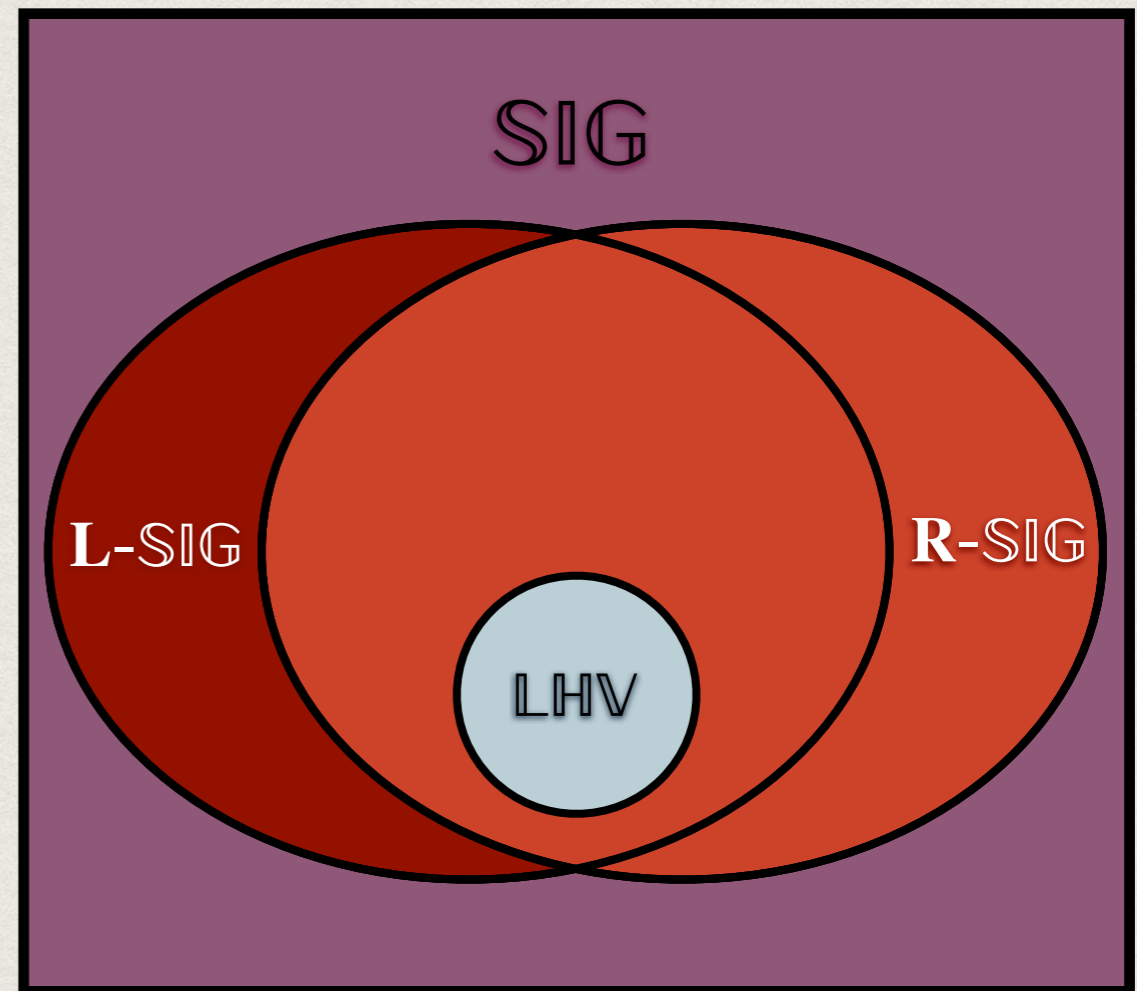

NON-LOCALITY HIERARCHIES

$|X\rangle = \text{Quantum analog of } X$

$|SIG\rangle$



SIG

L-SIG

R-SIG

LHV

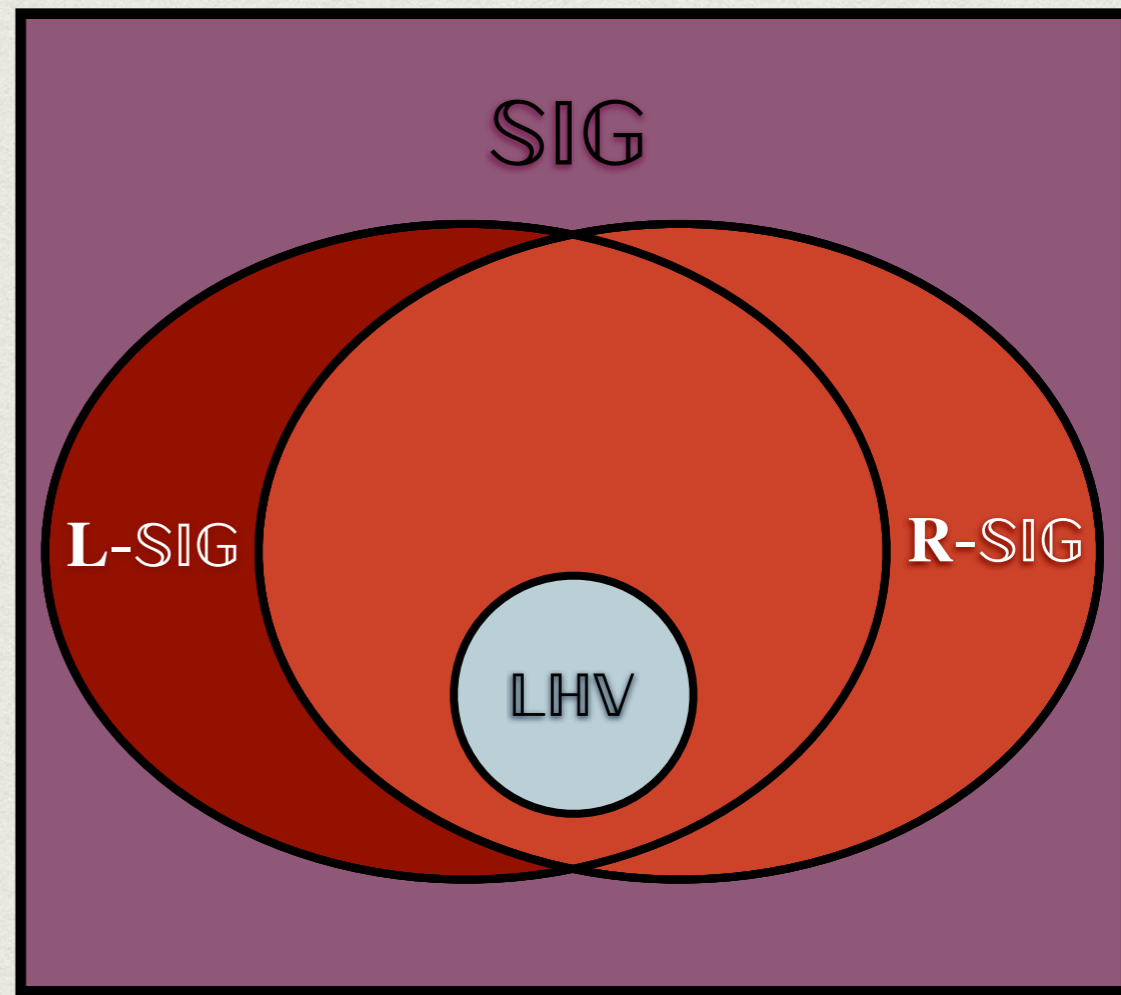
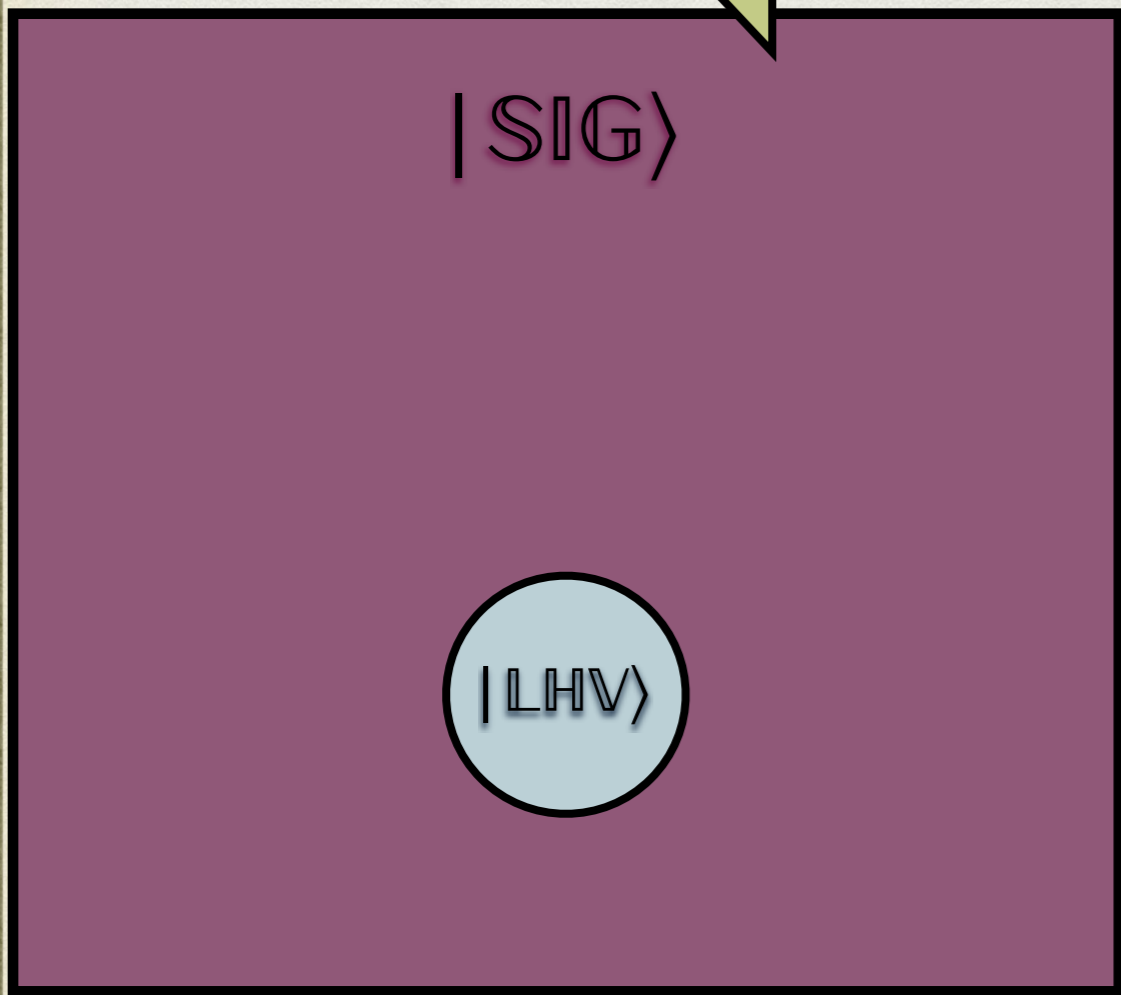

NON-LOCALITY HIERARCHIES

$|X\rangle = \text{Quantum analog of } X$

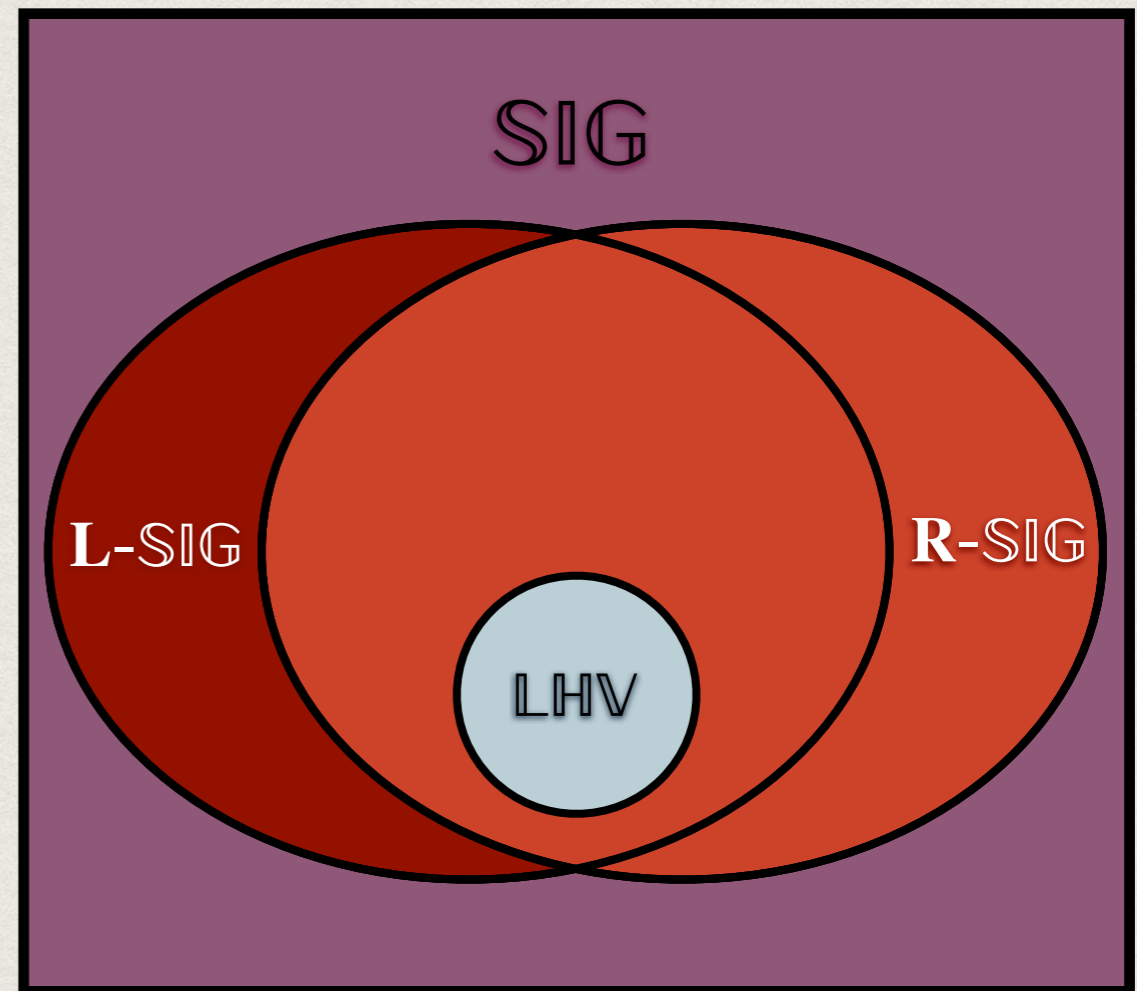
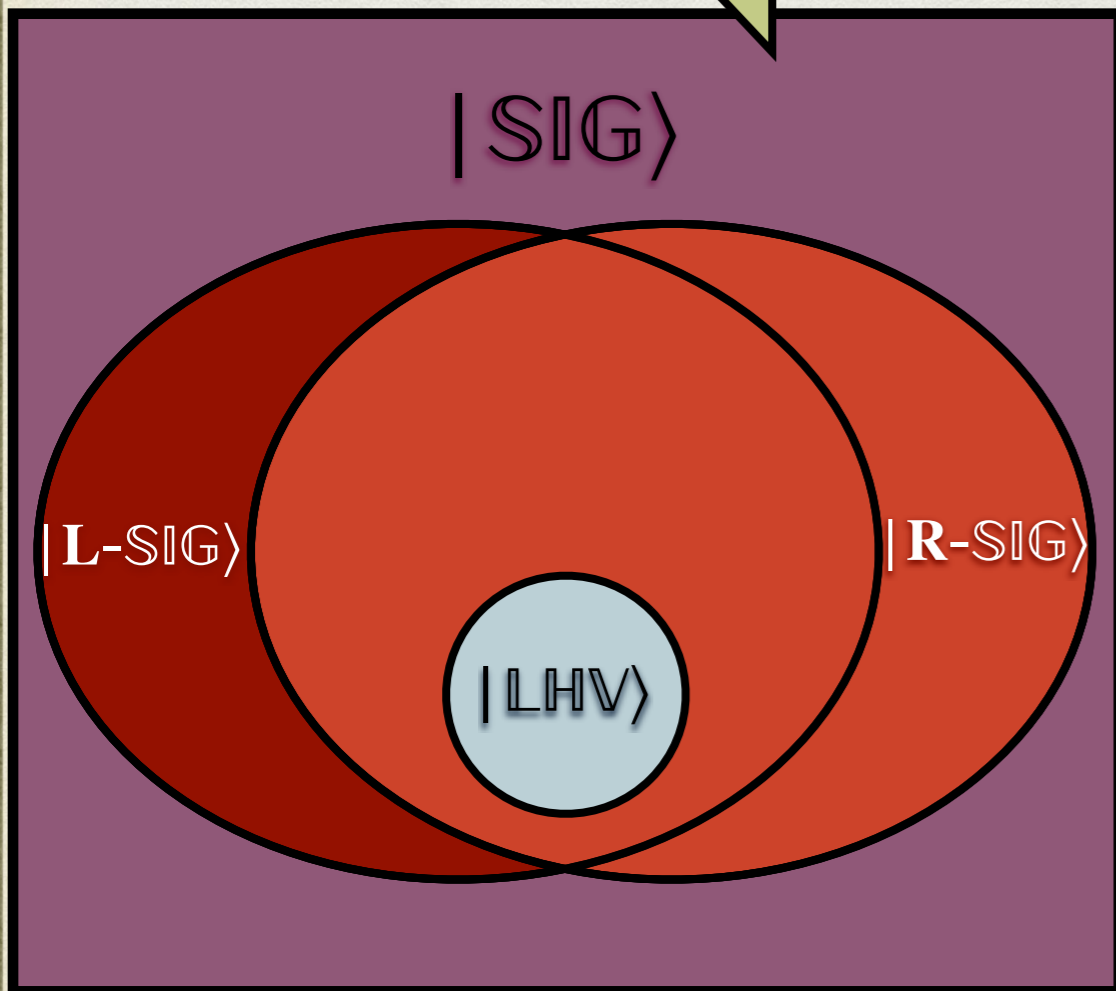

NON-LOCALITY HIERARCHIES

$|X\rangle = \text{Quantum analog of } X$

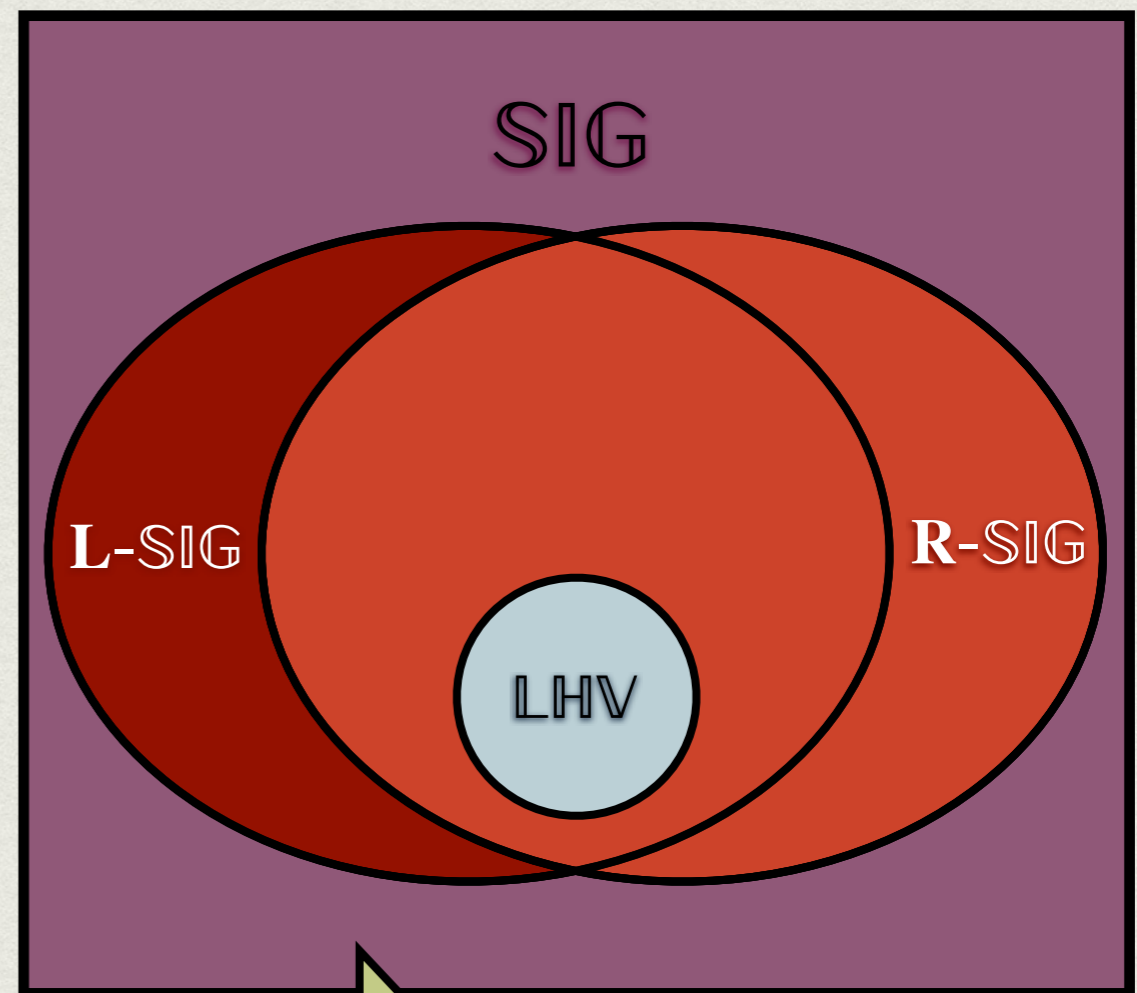
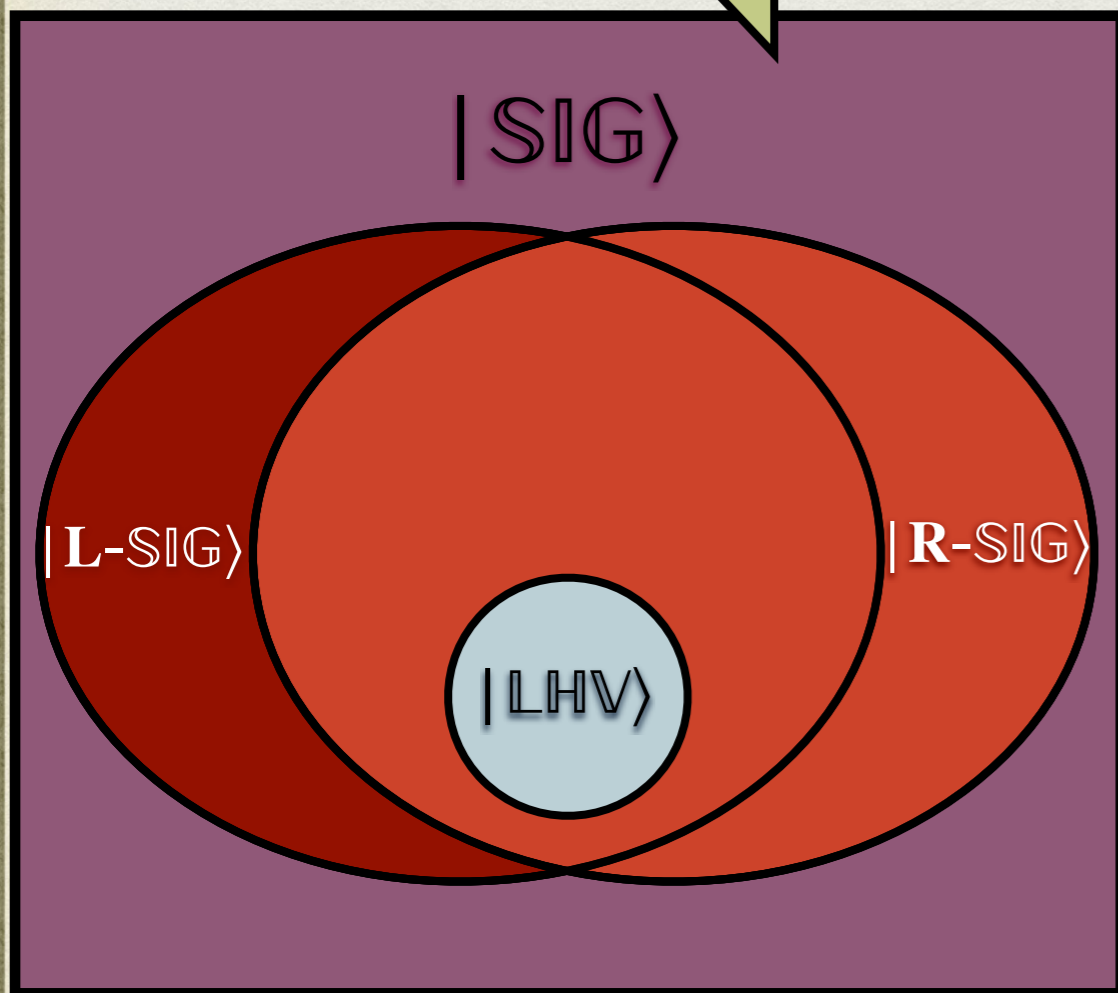

$\downarrow X \downarrow = \text{Classical projection of } X$

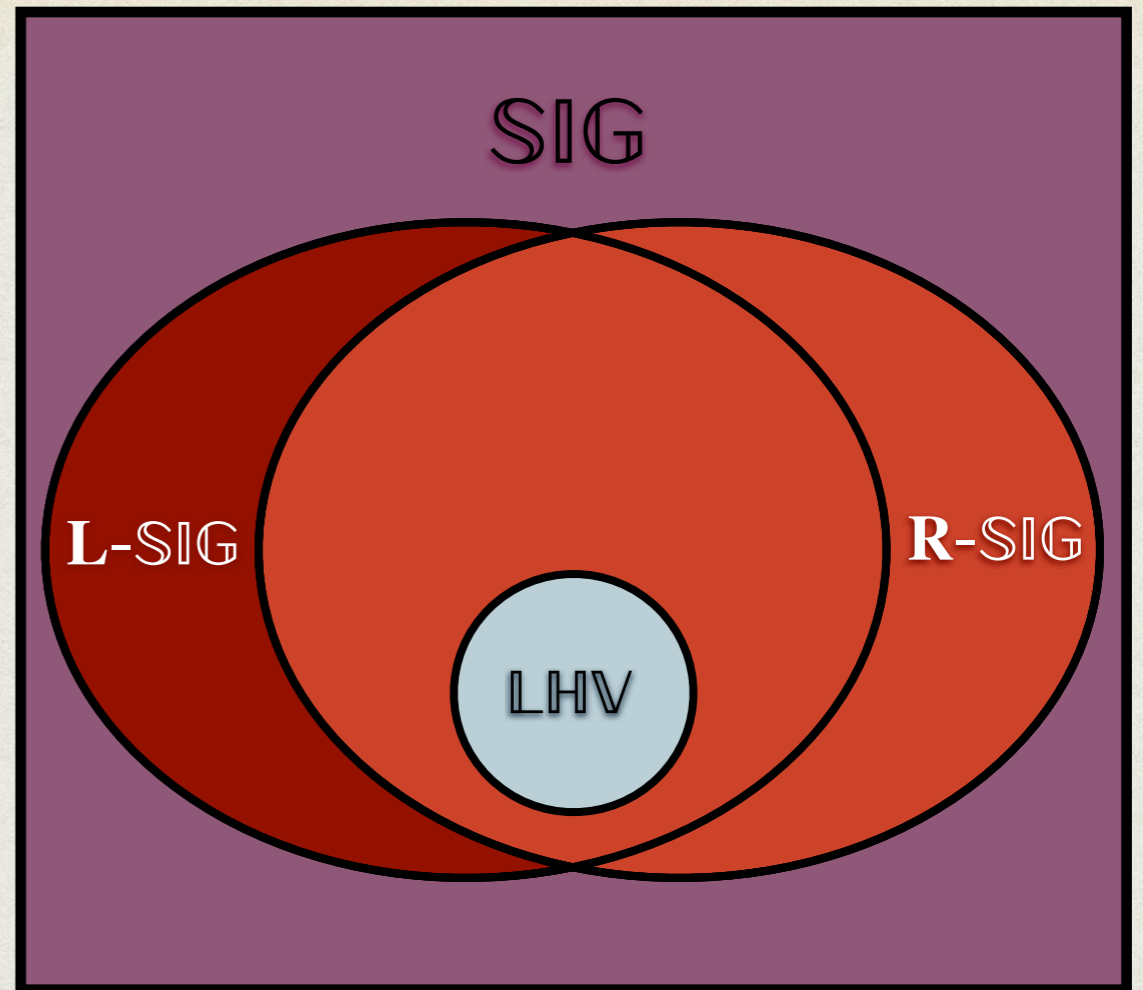
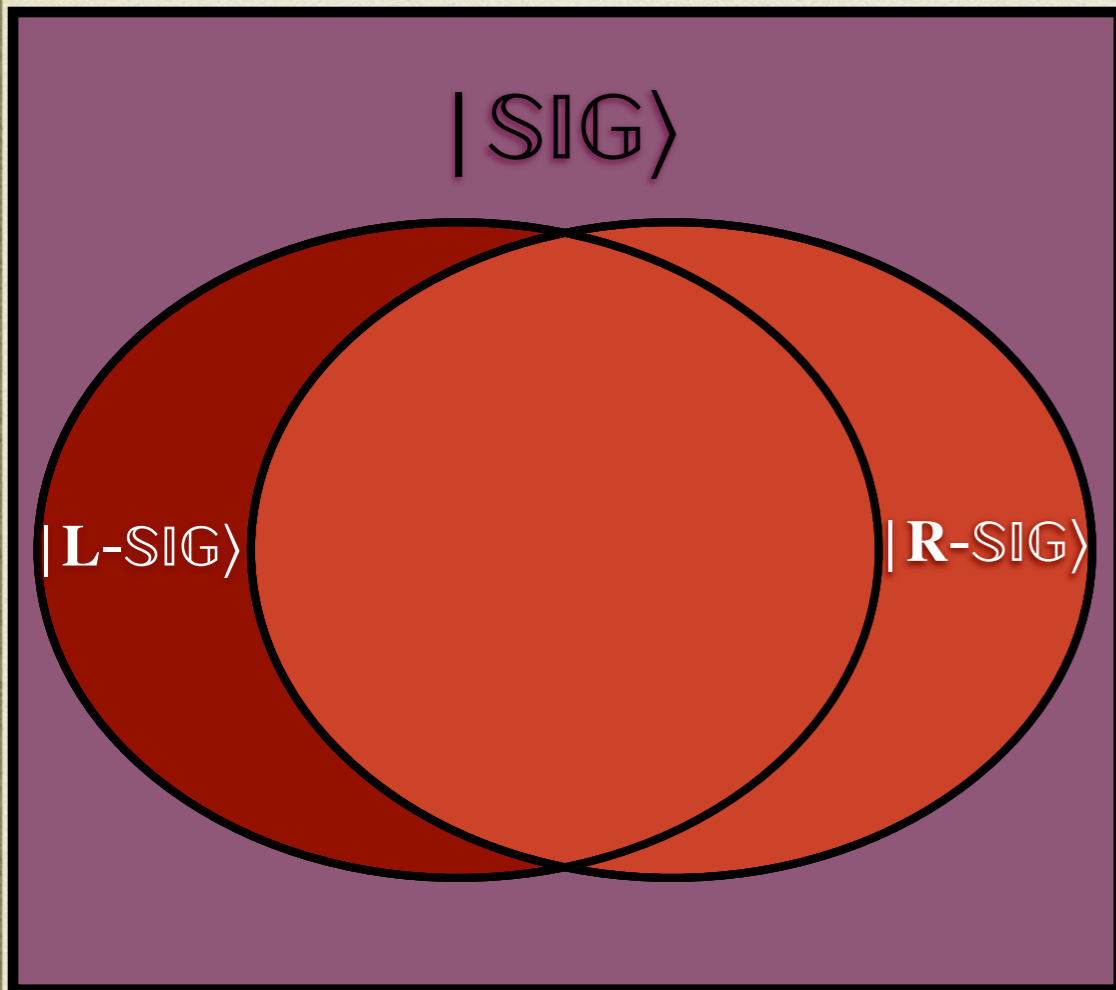

$$\downarrow |\text{SIG}\rangle \downarrow = \text{SIG}$$

$$\downarrow |\text{L/R-SIG}\rangle \downarrow = \text{L/R-SIG}$$

$$\text{NOSIG} \stackrel{\text{def}}{=} \text{L-SIG} \cap \text{R-SIG} = \downarrow |\text{NOSIG}\rangle \downarrow$$

$$\text{QNL} \stackrel{\text{def}}{=} \downarrow |\text{LHV}\rangle \downarrow, \quad |\text{LHV}\rangle = |\text{QNL}\rangle$$

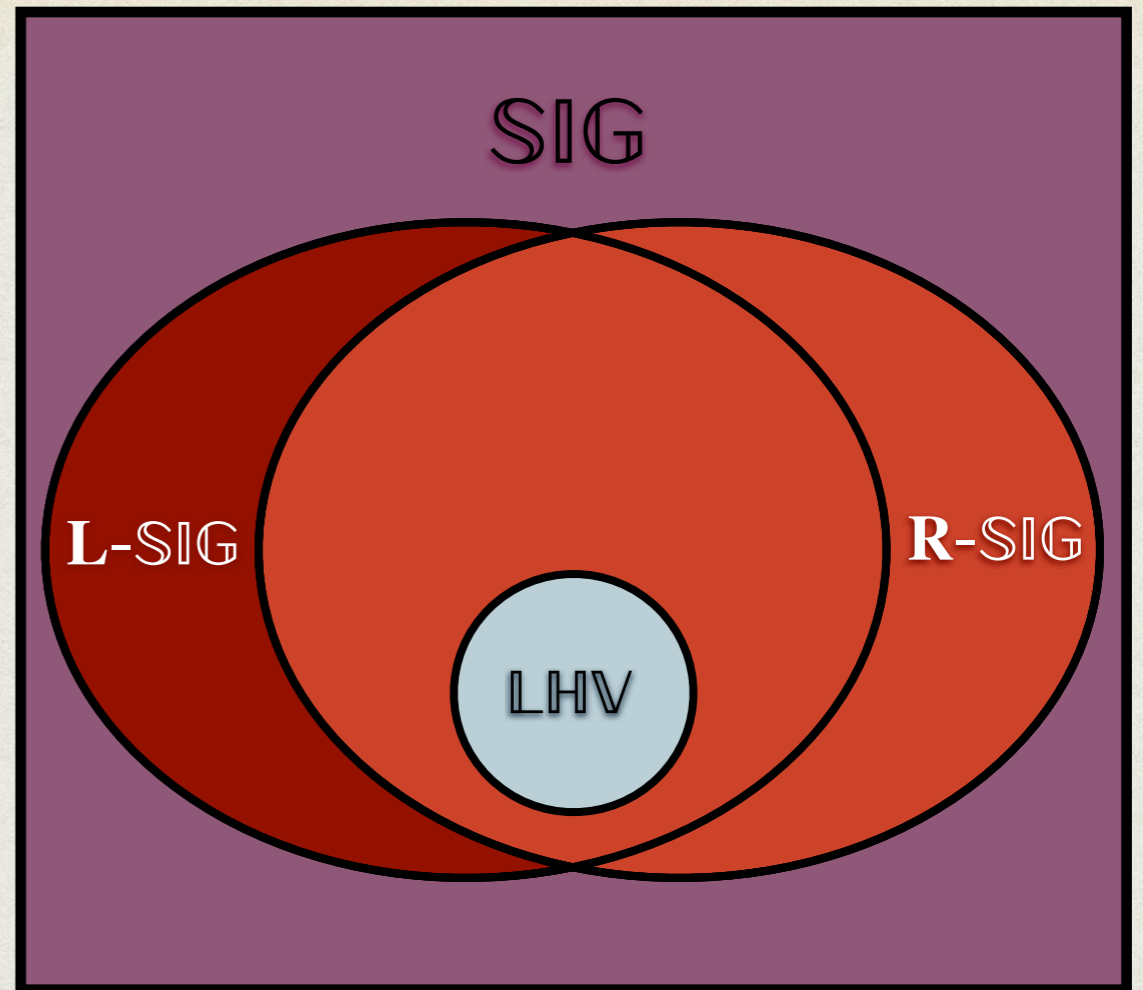
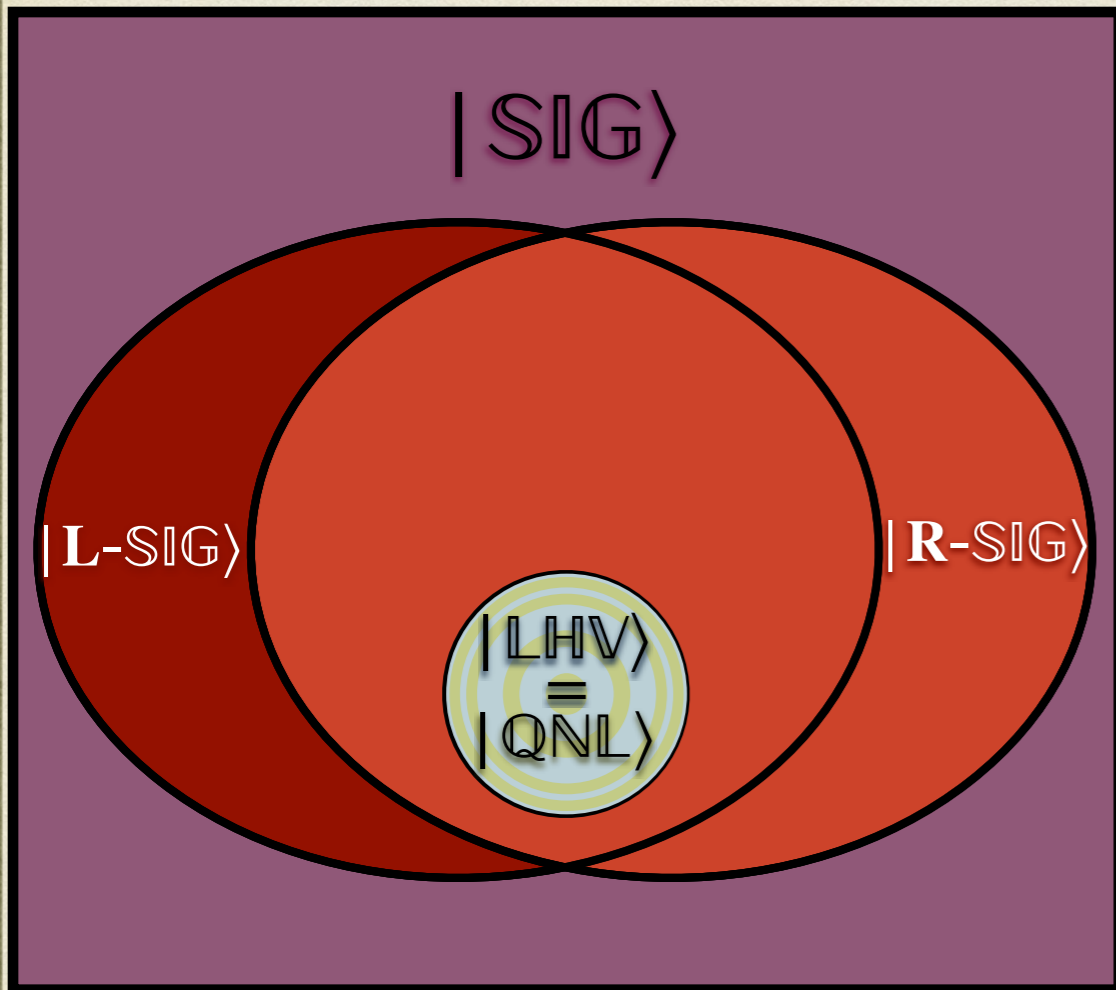

$$\downarrow |SIG\rangle \downarrow = SIG$$

$$\downarrow |L/R-SIG\rangle \downarrow = L/R-SIG$$

$$NOSIG \stackrel{\text{def}}{=} L-SIG \cap R-SIG = \downarrow |NOSIG\rangle \downarrow$$

$$QNL \stackrel{\text{def}}{=} \downarrow |LHV\rangle \downarrow, \quad |LHV\rangle = |QNL\rangle$$

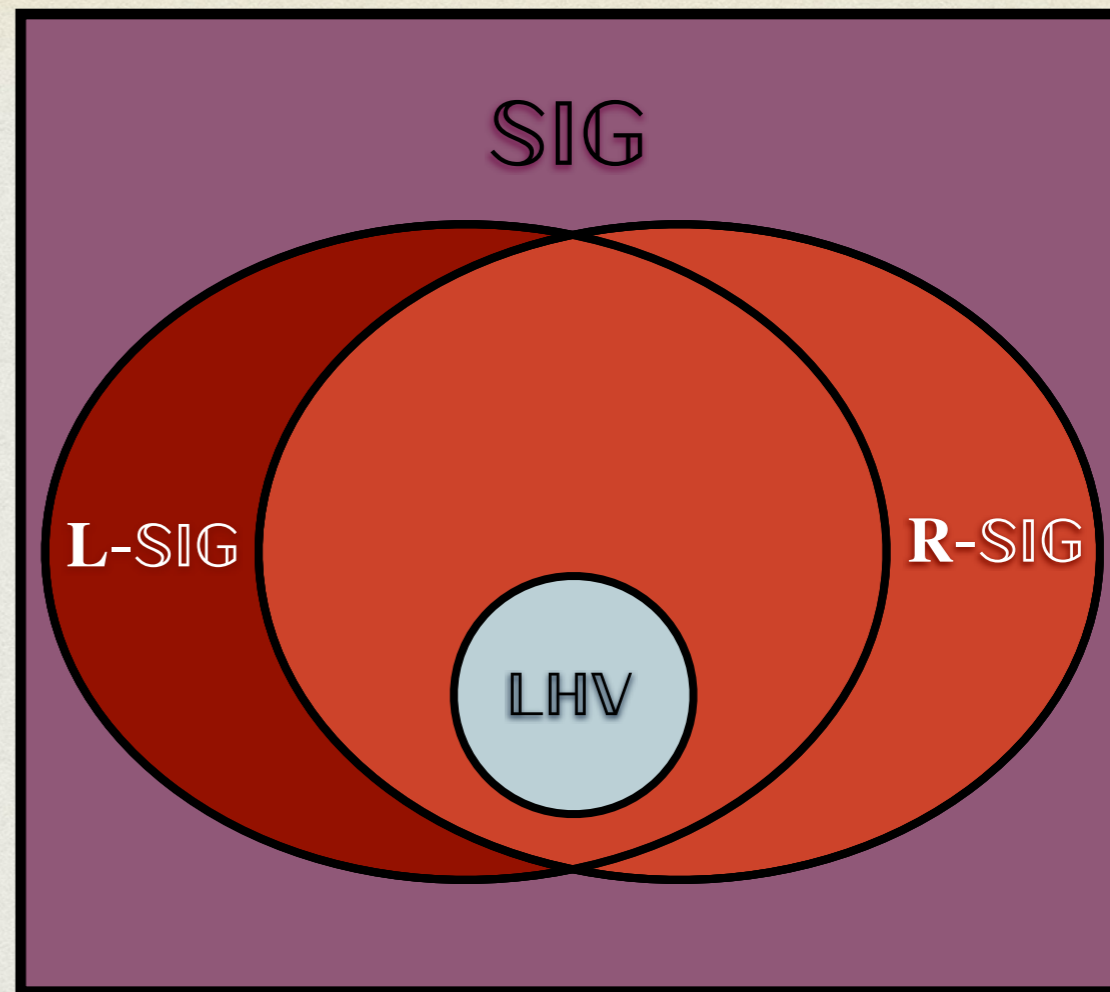
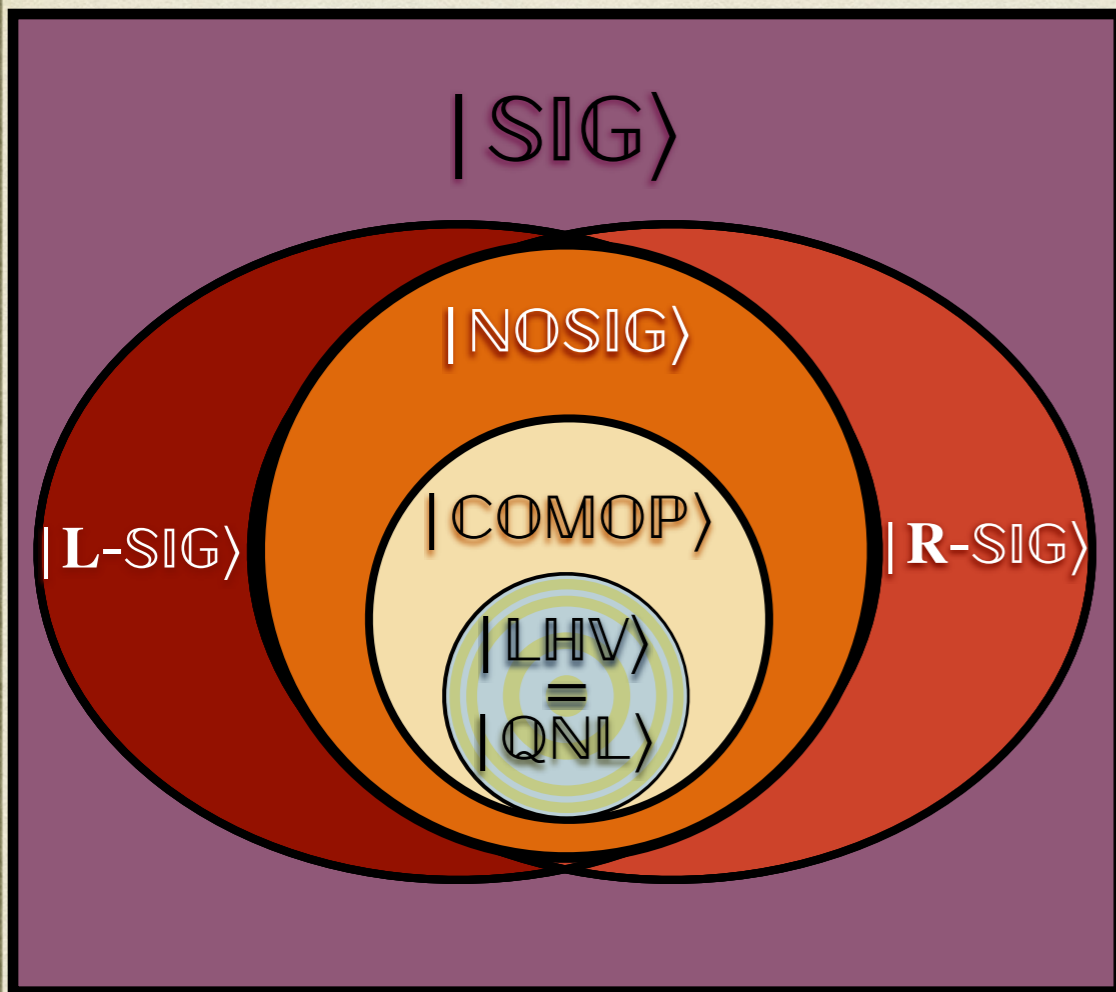

$$\downarrow |\text{SIG}\rangle \downarrow = \text{SIG}$$

$$\downarrow |\text{L/R-SIG}\rangle \downarrow = \text{L/R-SIG}$$

$$\text{NOSIG} \stackrel{\text{def}}{=} \text{L-SIG} \cap \text{R-SIG} = \downarrow |\text{NOSIG}\rangle \downarrow$$

$$\text{QNL} \stackrel{\text{def}}{=} \downarrow |\text{LHV}\rangle \downarrow, \quad |\text{LHV}\rangle = |\text{QNL}\rangle$$

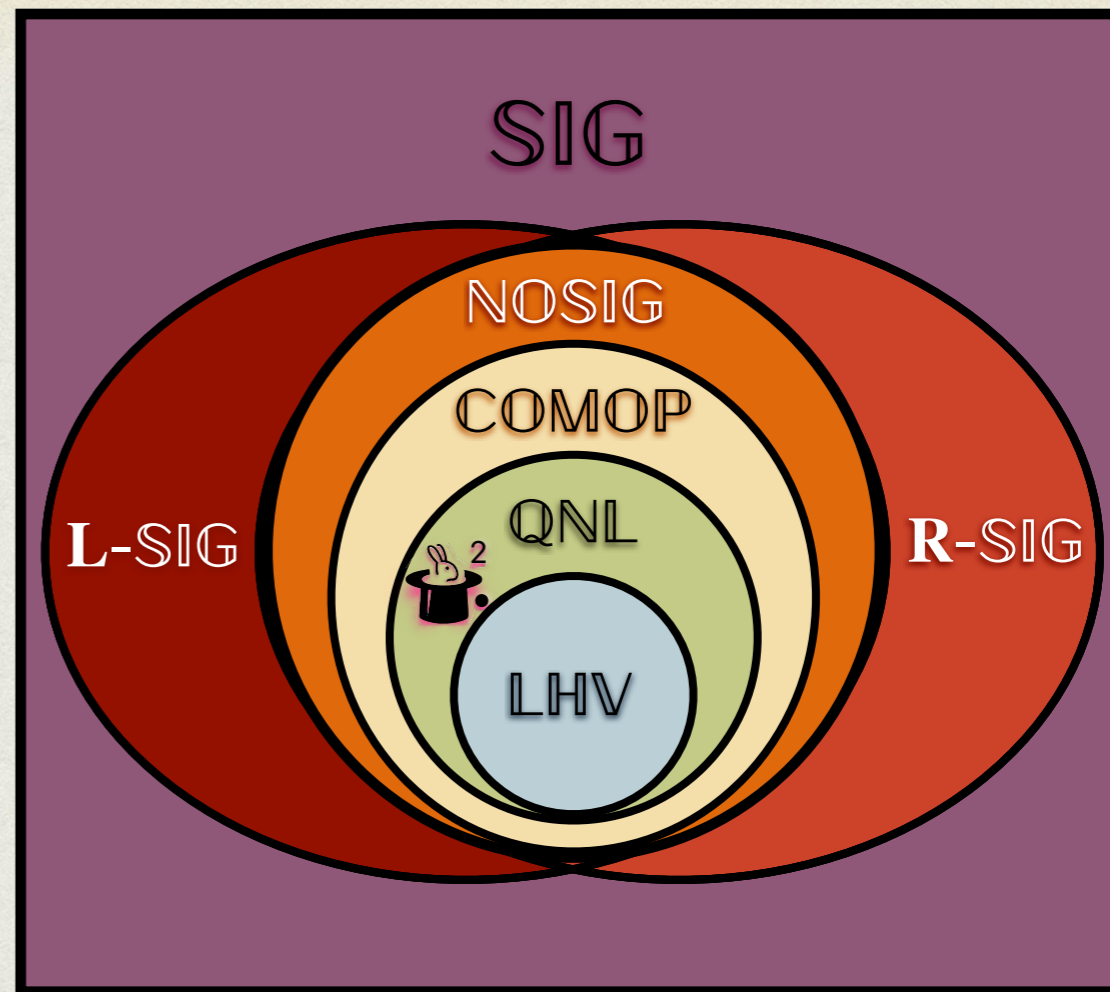
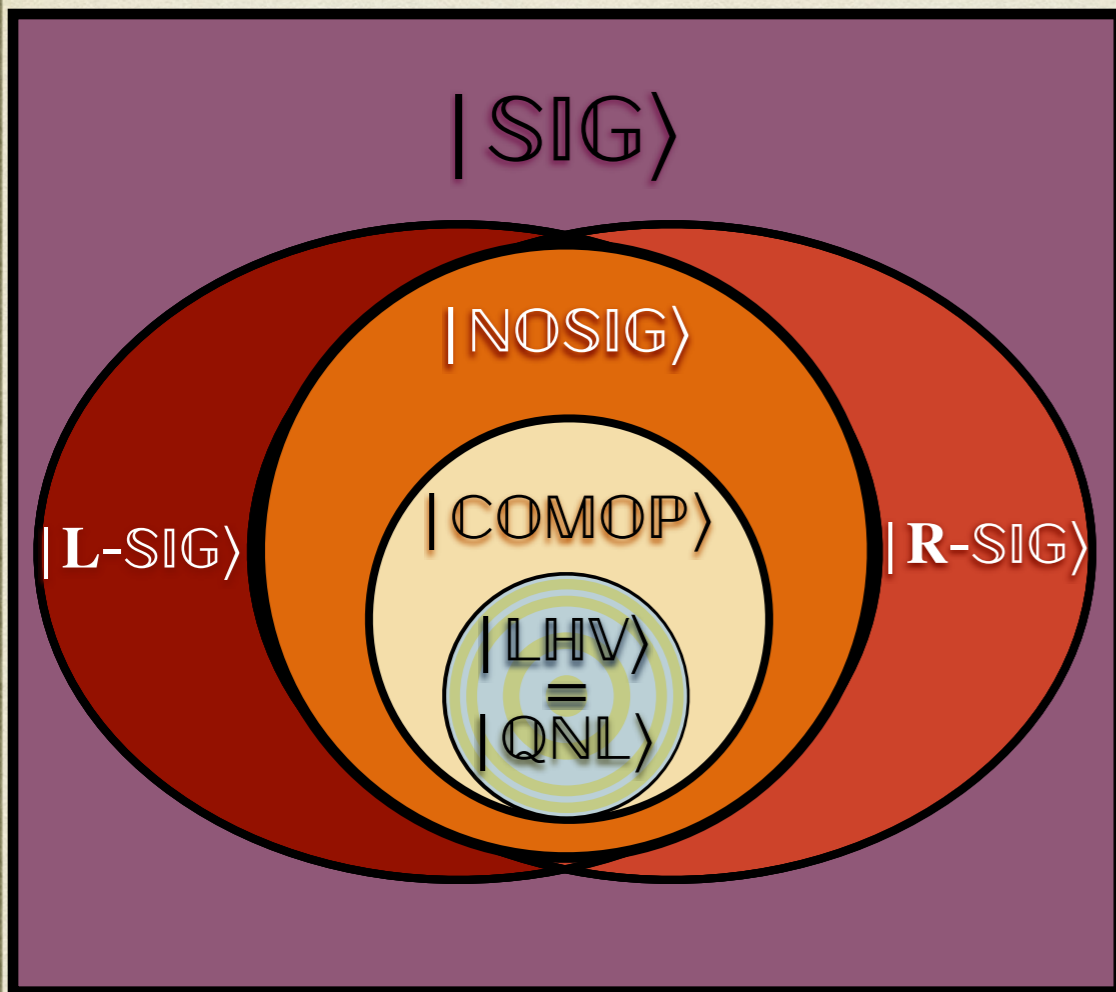

$$\downarrow |SIG\rangle \downarrow = SIG$$

$$\downarrow |L/R-SIG\rangle \downarrow = L/R-SIG$$

$$NOSIG \stackrel{\text{def}}{=} L-SIG \cap R-SIG = \downarrow |NOSIG\rangle \downarrow$$

$$QNL \stackrel{\text{def}}{=} \downarrow |LHV\rangle \downarrow, \quad |LHV\rangle = |QNL\rangle$$

Quantum Teleportation:

$$\mathbf{R-SIG} + |\mathbf{L-SIG}\rangle = |\mathbf{SIG}\rangle = \mathbf{L-SIG} + |\mathbf{R-SIG}\rangle$$

$$|\mathbf{NOSIG}\rangle \stackrel{\text{def}}{=} |\mathbf{L-SIG} \cap \mathbf{R-SIG}\rangle \stackrel{?}{=} |\mathbf{L-SIG}\rangle \cap |\mathbf{R-SIG}\rangle$$

$$\mathbf{L-SIG} + |\mathbf{LHV}\rangle = |\mathbf{L-SIG}\rangle$$

$$\mathbf{R-SIG} + |\mathbf{LHV}\rangle = |\mathbf{R-SIG}\rangle$$

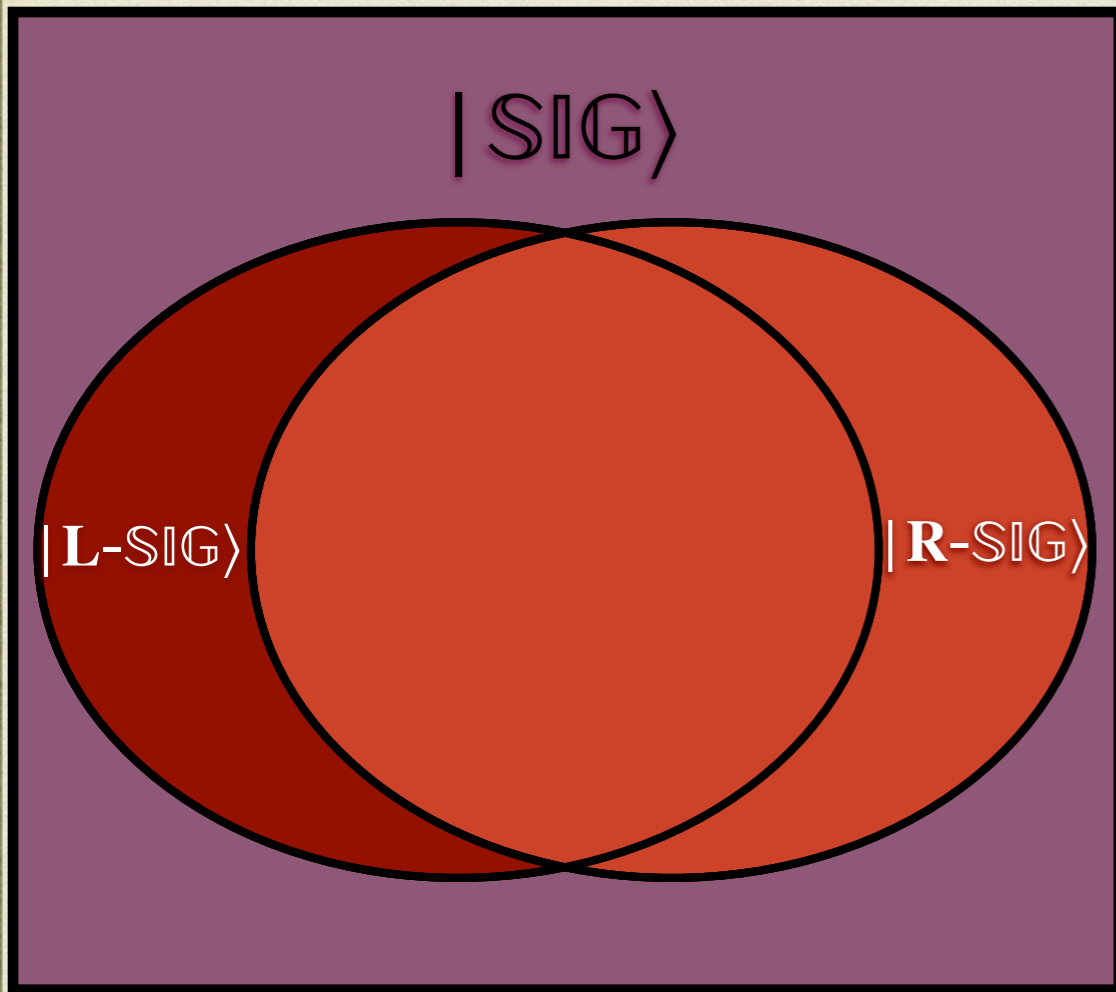

Quantum Teleportation:

$$\mathbf{R-SIG} + |\mathbf{L-SIG}\rangle = |\mathbf{SIG}\rangle = \mathbf{L-SIG} + |\mathbf{R-SIG}\rangle$$

$$|\mathbf{NOSIG}\rangle \stackrel{\text{def}}{=} |\mathbf{L-SIG} \cap \mathbf{R-SIG}\rangle \stackrel{?}{=} |\mathbf{L-SIG}\rangle \cap |\mathbf{R-SIG}\rangle$$

$$\mathbf{L-SIG} + |\mathbf{LHV}\rangle = |\mathbf{L-SIG}\rangle$$

$$\mathbf{R-SIG} + |\mathbf{LHV}\rangle = |\mathbf{R-SIG}\rangle$$

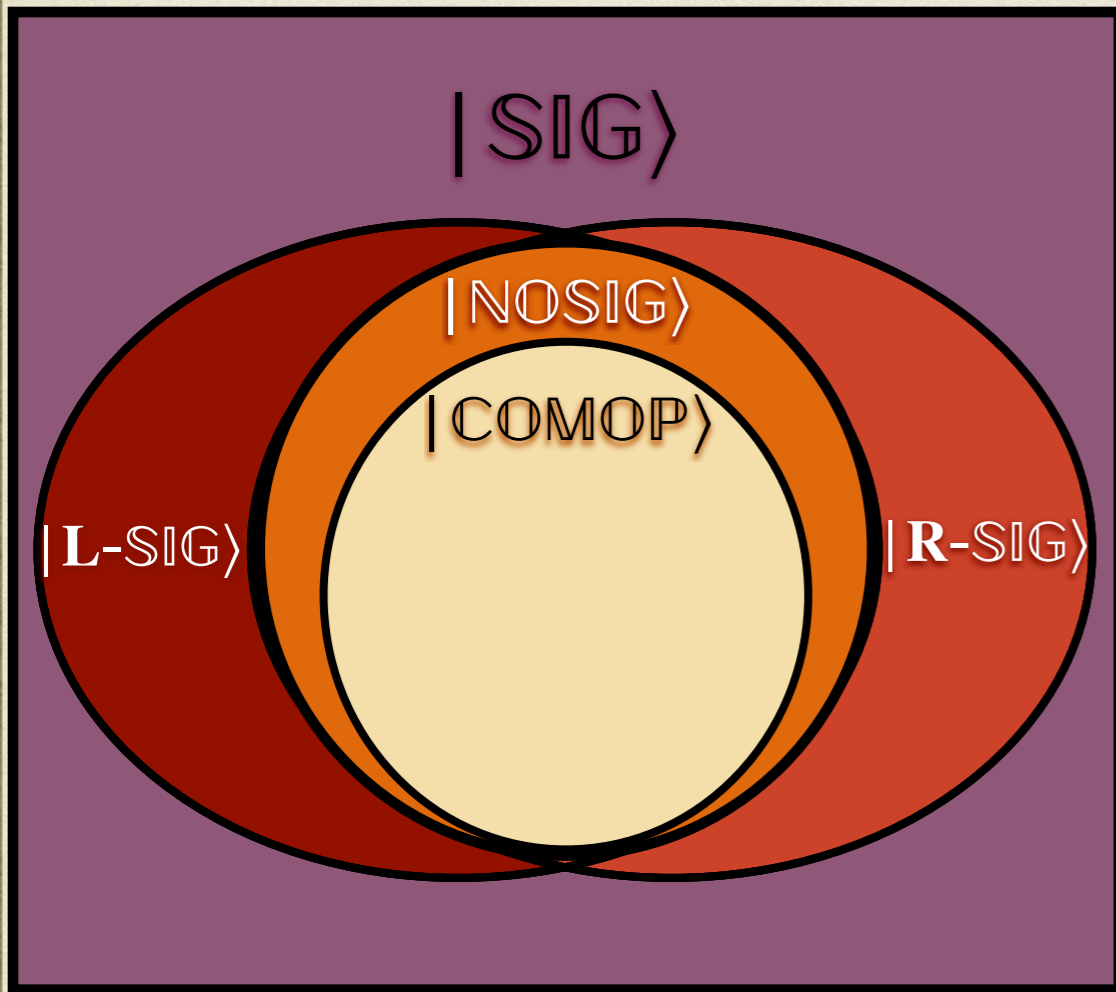

Quantum Teleportation:

$$\mathbf{R-SIG} + |\mathbf{L-SIG}\rangle = |\mathbf{SIG}\rangle = \mathbf{L-SIG} + |\mathbf{R-SIG}\rangle$$

$$|\mathbf{NOSIG}\rangle \stackrel{\text{def}}{=} |\mathbf{L-SIG} \cap \mathbf{R-SIG}\rangle \stackrel{?}{=} |\mathbf{L-SIG}\rangle \cap |\mathbf{R-SIG}\rangle$$

$$\mathbf{L-SIG} + |\mathbf{LHV}\rangle = |\mathbf{L-SIG}\rangle$$

$$\mathbf{R-SIG} + |\mathbf{LHV}\rangle = |\mathbf{R-SIG}\rangle$$

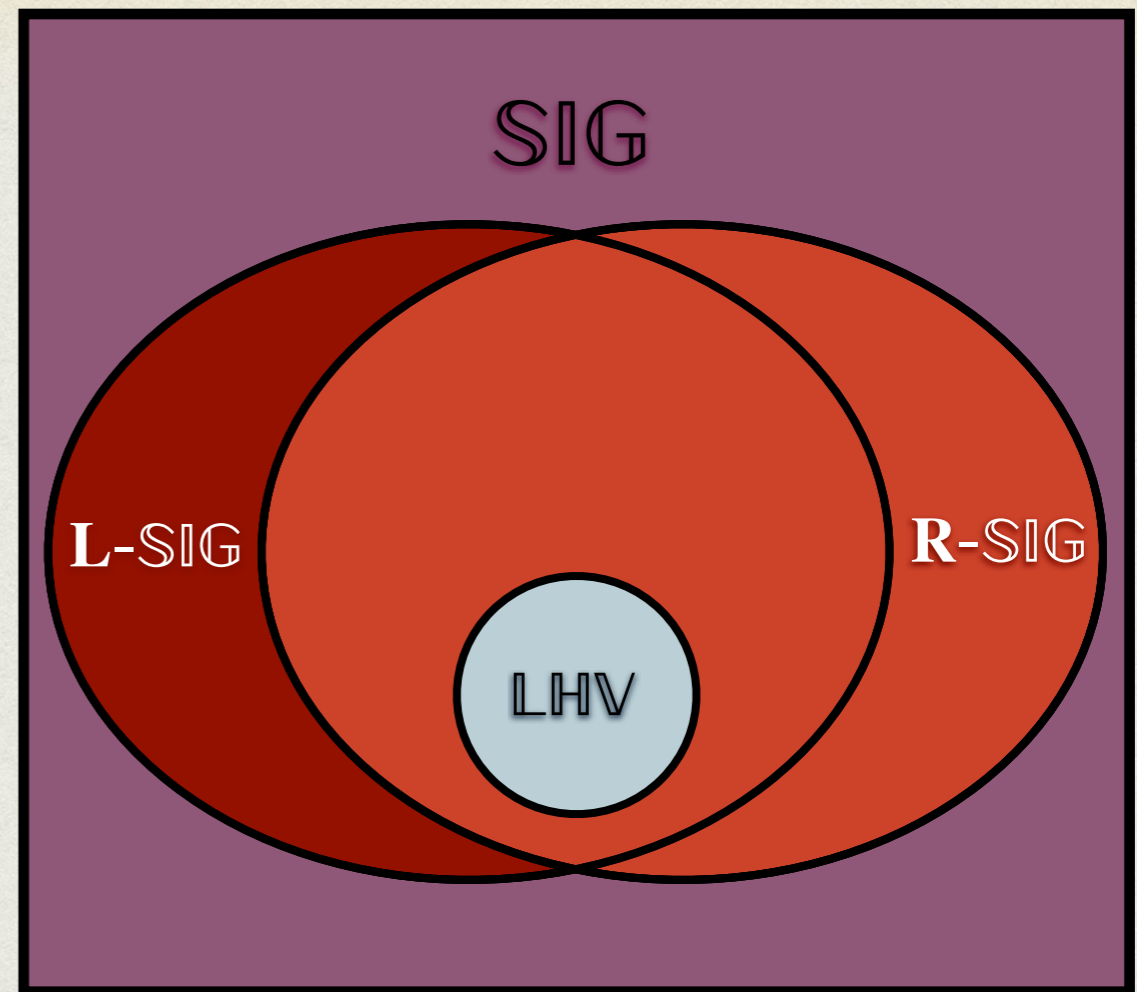
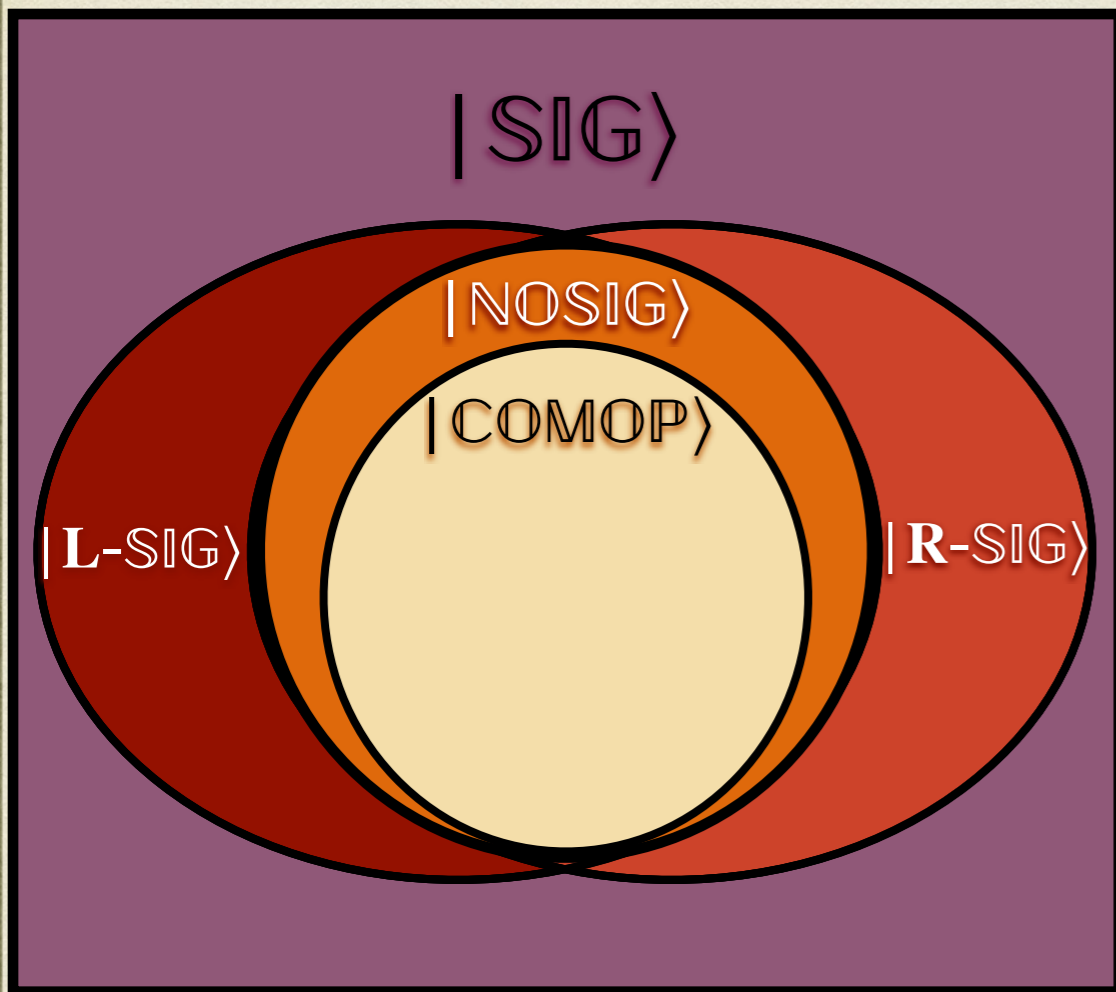

Quantum Teleportation:

$$\mathbf{R-SIG} + |\mathbf{L-SIG}\rangle = |\mathbf{SIG}\rangle = \mathbf{L-SIG} + |\mathbf{R-SIG}\rangle$$

$$|\mathbf{NOSIG}\rangle \stackrel{\text{def}}{=} |\mathbf{L-SIG} \cap \mathbf{R-SIG}\rangle \stackrel{?}{=} |\mathbf{L-SIG}\rangle \cap |\mathbf{R-SIG}\rangle$$

$$\mathbf{L-SIG} + |\mathbf{LHV}\rangle = |\mathbf{L-SIG}\rangle$$

$$\mathbf{R-SIG} + |\mathbf{LHV}\rangle = |\mathbf{R-SIG}\rangle$$

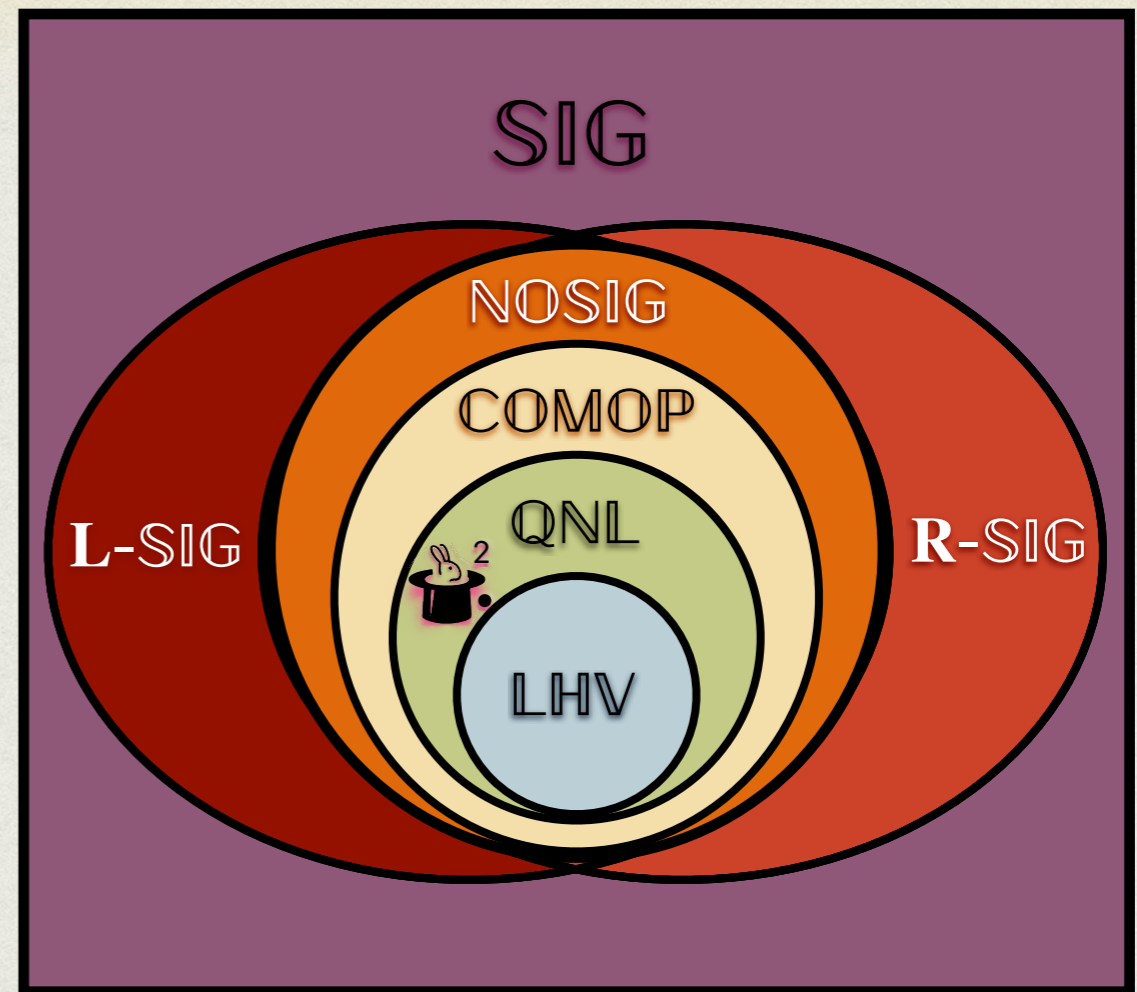
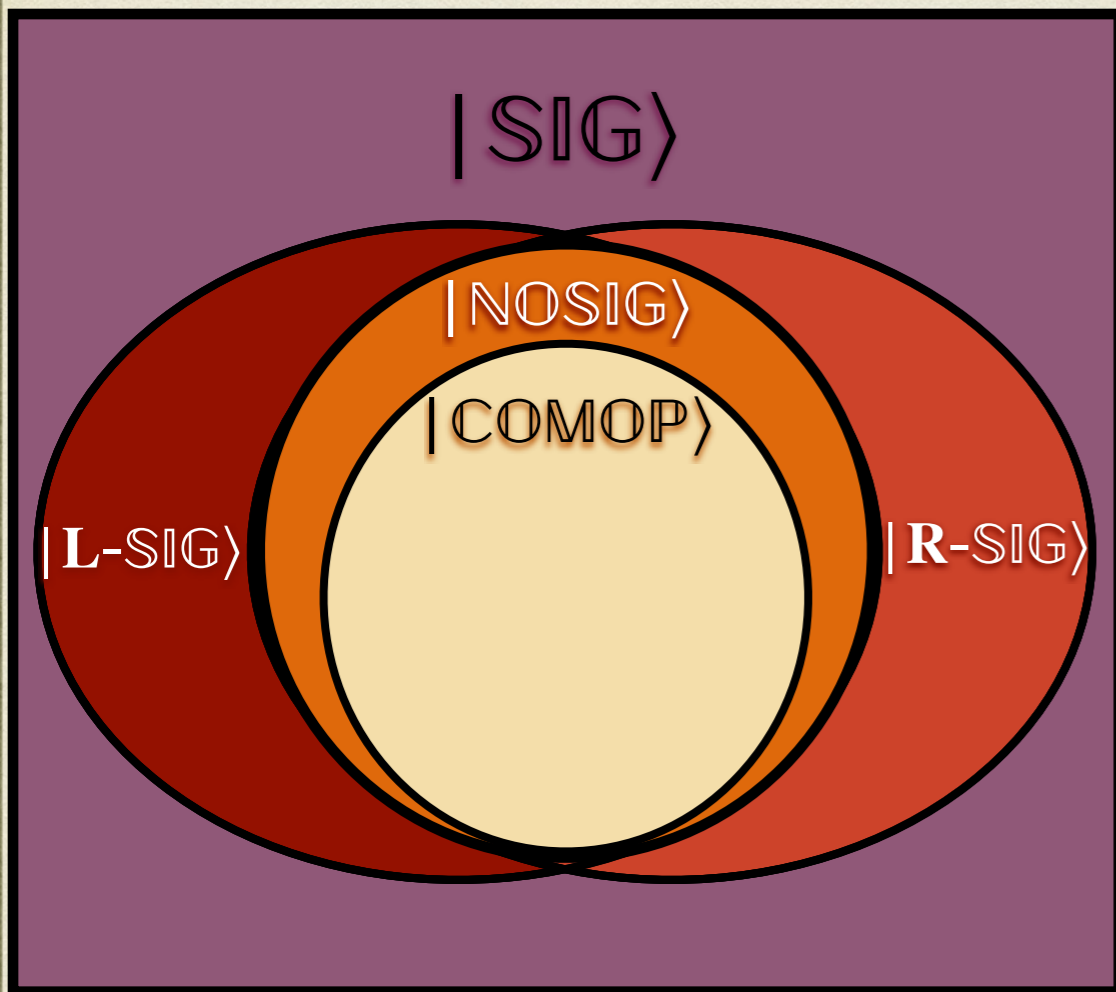

Quantum Teleportation:

$$\mathbf{R-SIG} + |\mathbf{L-SIG}\rangle = |\mathbf{SIG}\rangle = \mathbf{L-SIG} + |\mathbf{R-SIG}\rangle$$

$$|\mathbf{NOSIG}\rangle \stackrel{\text{def}}{=} |\mathbf{L-SIG} \cap \mathbf{R-SIG}\rangle \stackrel{?}{=} |\mathbf{L-SIG}\rangle \cap |\mathbf{R-SIG}\rangle$$

$$\mathbf{L-SIG} + |\mathbf{LHV}\rangle = |\mathbf{L-SIG}\rangle$$

$$\mathbf{R-SIG} + |\mathbf{LHV}\rangle = |\mathbf{R-SIG}\rangle$$

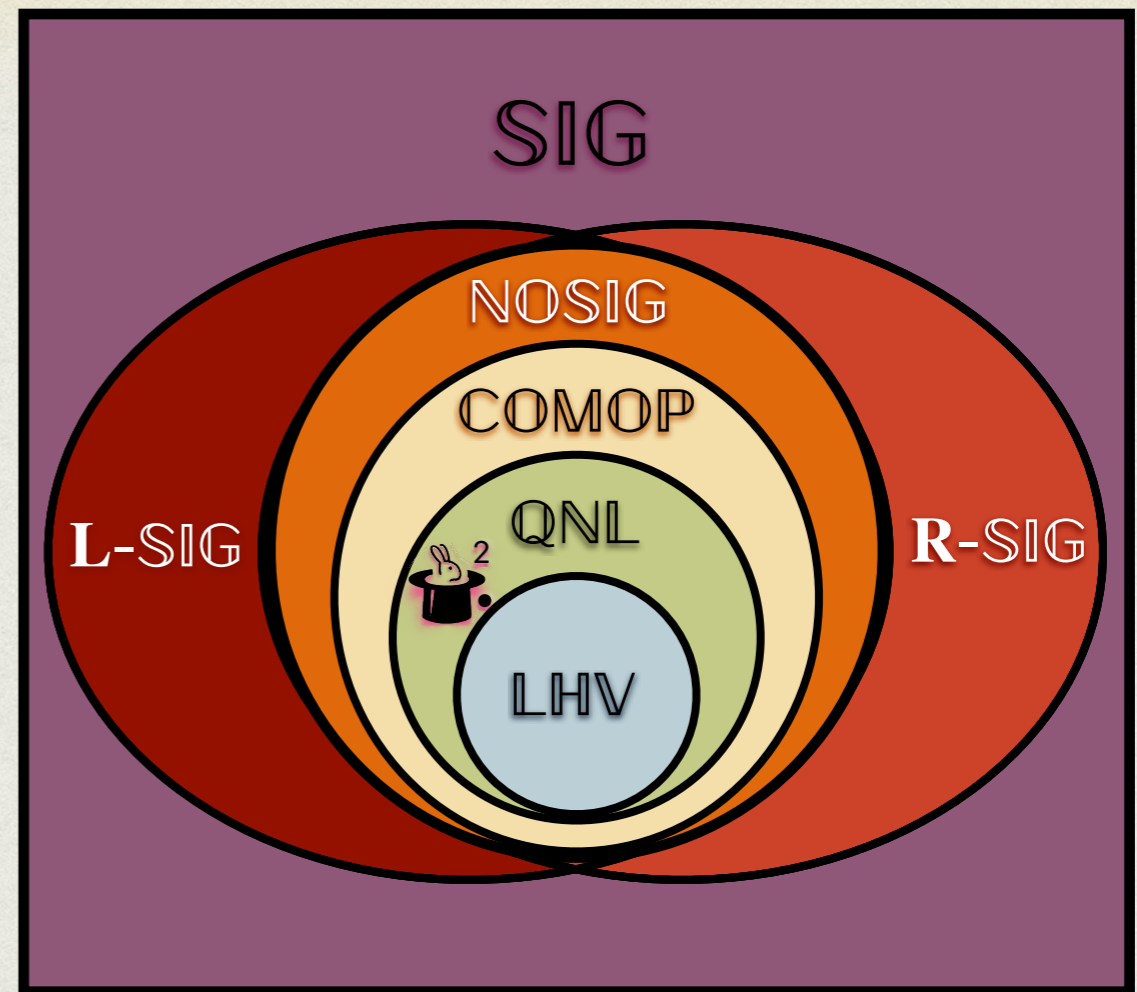
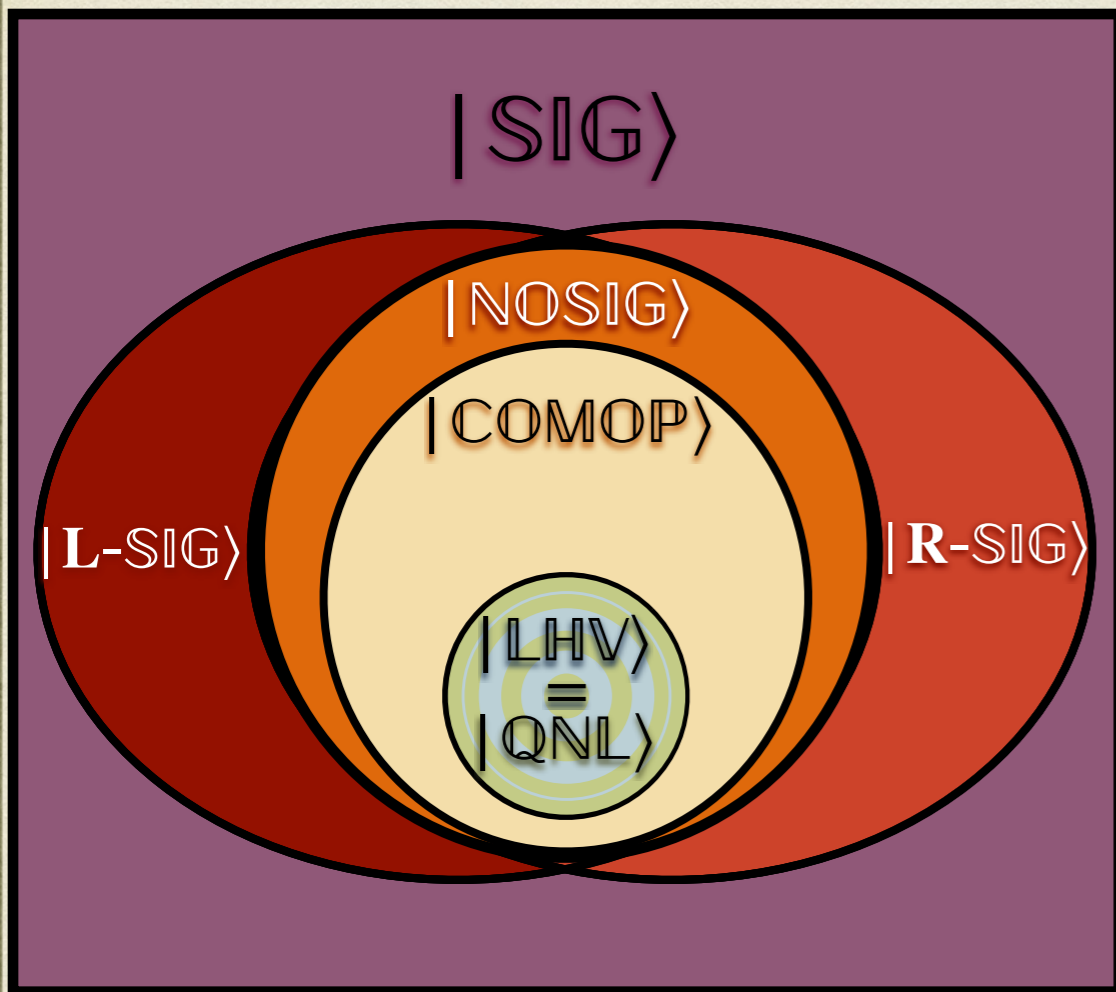

Quantum Teleportation:

$$\mathbf{R-SIG} + |\mathbf{L-SIG}\rangle = |\mathbf{SIG}\rangle = \mathbf{L-SIG} + |\mathbf{R-SIG}\rangle$$

$$|\mathbf{NOSIG}\rangle \stackrel{\text{def}}{=} |\mathbf{L-SIG} \cap \mathbf{R-SIG}\rangle \stackrel{?}{=} |\mathbf{L-SIG}\rangle \cap |\mathbf{R-SIG}\rangle$$

$$\mathbf{L-SIG} + |\mathbf{LHV}\rangle = |\mathbf{L-SIG}\rangle$$

$$\mathbf{R-SIG} + |\mathbf{LHV}\rangle = |\mathbf{R-SIG}\rangle$$

MAGIC

		y_{0j}
x_{i0}	x_{i1}	$x_{i2} = y_{2j}$
		y_{2j}

SQUARE

$$A=B=\{0,1,2\}, X=Y=\{0,1\}^3$$

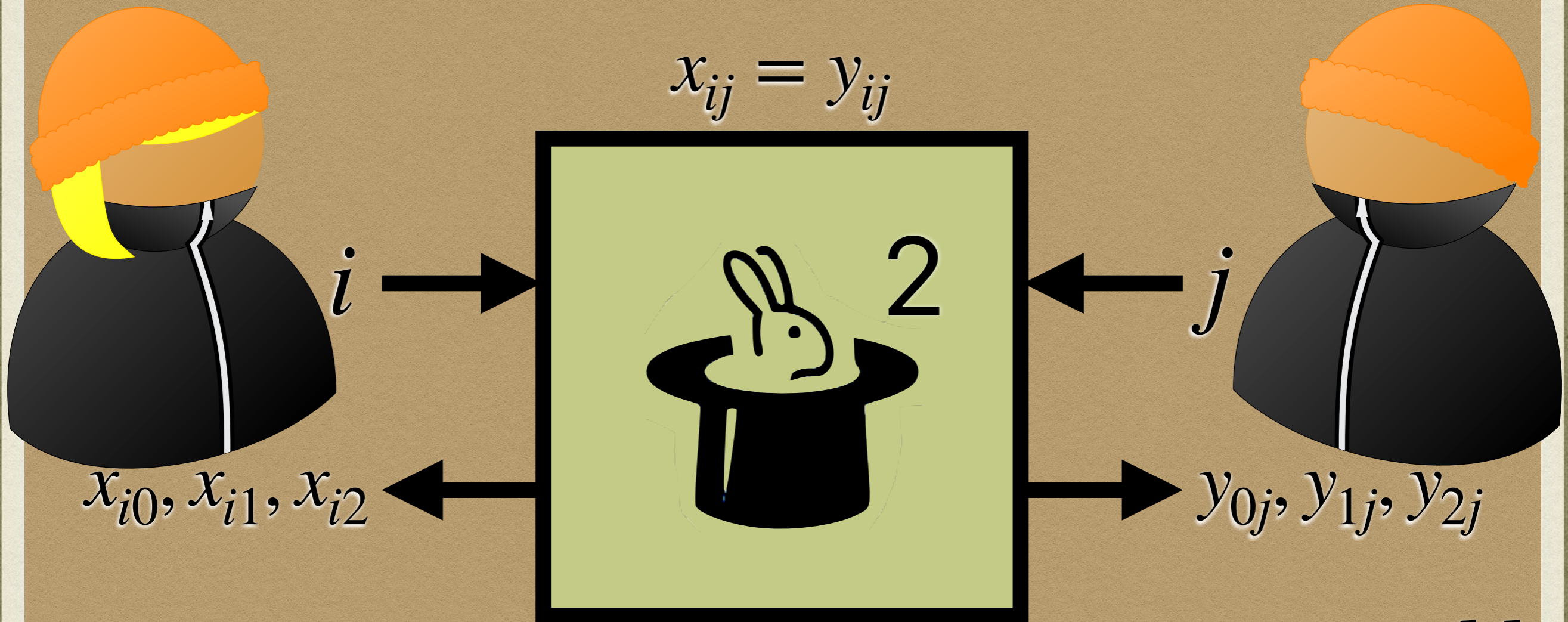

$$x_{i0} + x_{i1} + x_{i2} = \text{even}$$

$$y_{0j} + y_{1j} + y_{2j} = \text{odd}$$