

# Strategic R&D Programme on Technologies for future Experiments

**R&D**  
on EXPERIMENTAL  
TECHNOLOGIES

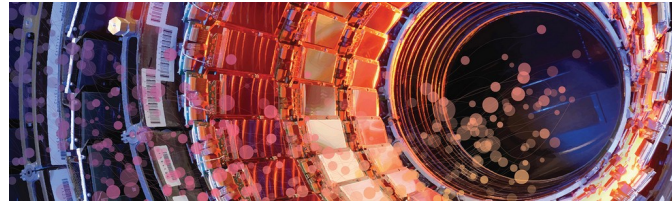

**ICHEP 2020 | PRAGUE**

40<sup>th</sup> INTERNATIONAL CONFERENCE  
ON HIGH ENERGY PHYSICS

**VIRTUAL  
CONFERENCE**

**28 JULY - 6 AUGUST 2020**  
PRAGUE, CZECH REPUBLIC

**Esteban Currás**  
(CERN-EP-DT-DD)  
On behalf of EP R&D Programme



# Outlook

- Introduction to the R&D programme
- Implementation and work programme
- Review of some ongoing R&D activities/projects
- Summary



*EP R&D website: <https://test-ep-rnd.web.cern.ch/>*

# Introduction to the R&D programme

- Many important developments and facilities being used now at CERN were initiated and/or boosted more than 10 years ago during the “**White Paper**” R&D programme (2008-2011).
  - RadHad DC-DC converters, ASICs in 130 nm technology, GIF++ ...

Development cycles are long:  
> 1 decade (see White Paper R&D)

R&D for LHC phase-II upgrades  
comes to an end around 2020

R&D requires expertise, experience,  
infrastructure and continuity

**Now is the right time  
to launch a new R&D  
programme**

The next generation accelerators/experiments  
are still very far in the future!

- We defined a ‘strategic’ technological R&D programme, rather than an experiment specific programme.
- Its results shall enable future projects to develop and build optimal detectors.
- We use the requirements of HL-LHC and studies like, FCC (ee/hh) as guidelines.

# Introduction to the R&D programme

## Instrumentation Challenges in future detectors !

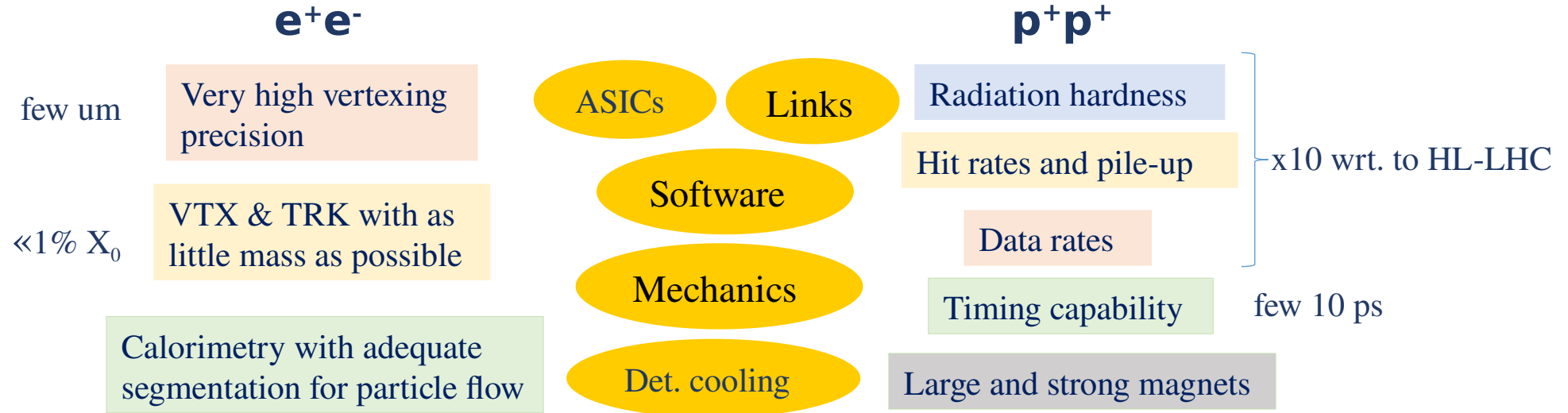

Resources are limited  $\rightarrow$  Selection and priorities is needed. Focus on areas...

- where CERN has already significant expertise and infrastructure
- where CERN plays (needs to play) a leading/ unique role
- which will be key for the success of future projects

# Implementation and work programme

## › Process:

- Kick off meeting in November 2017.
- Two R&D work-shops in March and September 2018.
- Plan and budget presented in November 2018.
- MTP 2019 presented in June 2019. Budget line for 2020-2024: ~ 25 MCHF (~ 62% of request)
- Final workplan presented in October 2019 → **We are ready to go !!**

Steering Committee

12 persons, chaired by Department Head Manfred Kramer

Programme Coordinator

Deputy Department Head Christian Joram

## › Divided in **11 WPs**: 11 WP Leaders + Deputies, 11 individual budgets

- Work carried out by fellows and students supervised by staff.
- There is not specific R&D group at CERN.

# Implementation and work programme

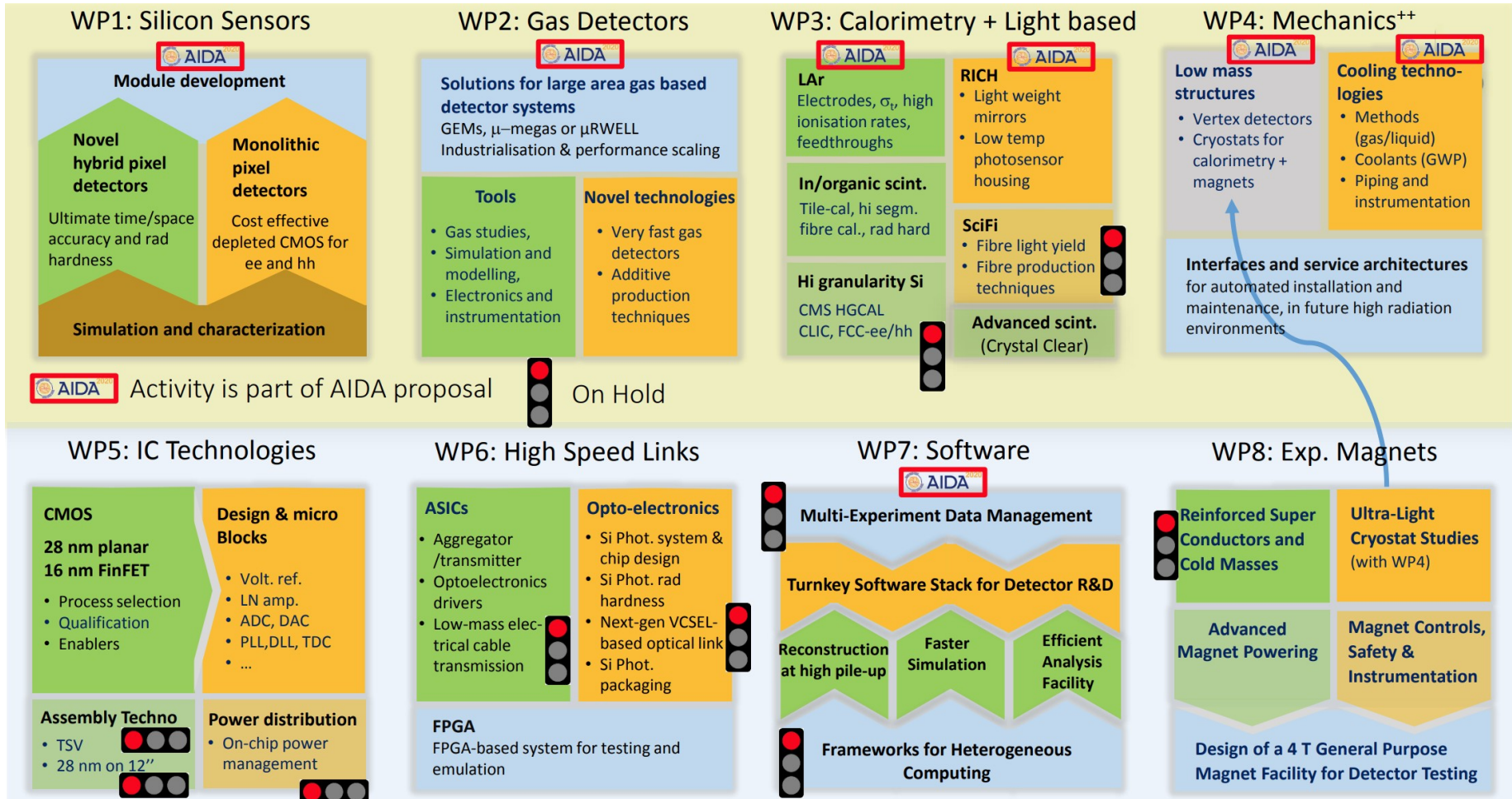

## WP 1 Silicon Sensors:

- 1.1 → Silicon Hybrid detectors (Victor Coco)
- 1.2 → Monolithic Pixel Sensors (Christian Joram)
- 1.3 → Silicon Modules (Petra Riedler)
- 1.4 → Simulation and Characterization (Michael Moll)

I am mainly involved in these two activities

**Time resolution**  
aiming at <50ps

3D sensor arXiv:1901.02538

ILGAD arXiv:1904.02061

+ thin planar (50-100µm) for ref.

**Spatial resolution**

+ fine pitch (25x25µm) planar sensors

(a) No GR  
Thin - Active Edge planar sensors  
CLIC arXiv:1904.09953

## Silicon Hybrid Sensors

Target demanding applications that requires specializes sensors and/or complex ASICs features, e.g. LHCb VELO (LS4):

**IC block development**

Specific ASIC development for

- fine time bin (~20ps)
- fine pitch (25µm).

**Close links with IC and High Speed links WP**

- high fluence ( $> 10^{16} n_{eq}/cm^2/y$ ),
- high hit rate  $O(10 \text{ Ghits/s/cm}^2)$ ,
- high output bandwidth  $O(100 \text{ Gb/s})$

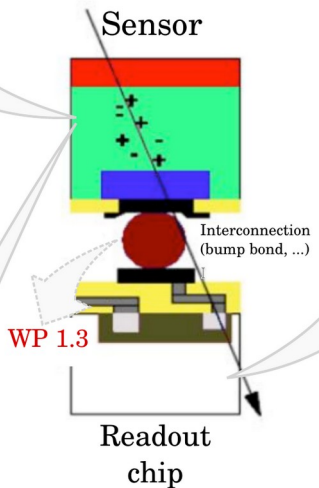

- Several type sensors will be studied (planar, 3d sensors, LGADs).
- Activities started this year on test benches and simulation

Upgrade of the beta source [V. Gkougkousis]

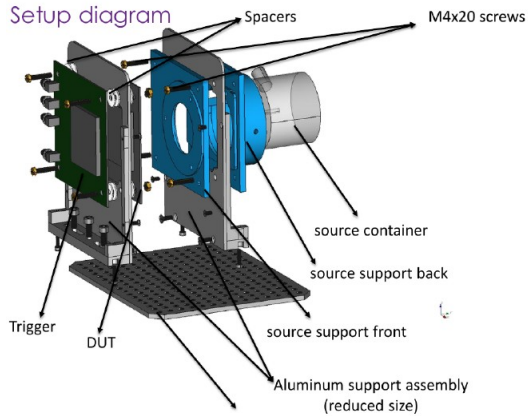

Signal generation simulation [M. Halvorsen]  
(Garfield++ / amplifier transfer function)

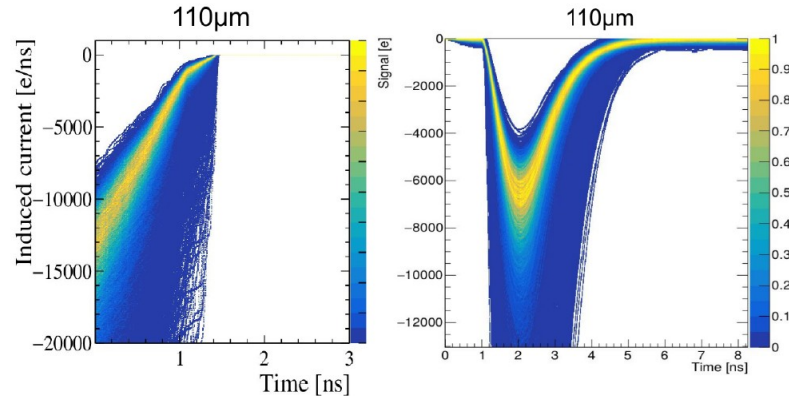

- ASIC design related activities to start mid-2021.
  - Simulation effort (TCAD + signal propagation + electronic response simulation) on-going to provide inputs for the design.
  - Will be based on technology chosen by IC WP for next generation of ASIC.
  - Design and test blocks for analog front-end targeting time jitter of <50ps or small pitch pixels <50µm.
  - Design and test digital blocks (fast TDC, clock distribution...)
  - Work in collaboration with WP 5 and 6 and EP-ESE group

# Review of some ongoing R&D activities/project

## Monolithic Pixel Sensors

- Phase 1:
  - An initial technology selection and validation (EP-ESE) and asynchronous architecture study (MALTA) in 180 nm.
- Phase 2:
  - Pre-prototyping of a large, low-power and high-resolution sensor (ITS-3 sensor for ALICE/e+e-)
  - Pre-prototyping of a fast and rad hard sensor (for high luminosity general purpose experiments)
  - Continuation of common activity: Technology monitoring and survey, training, design and measurement framework
  - Other explorations depending on findings...

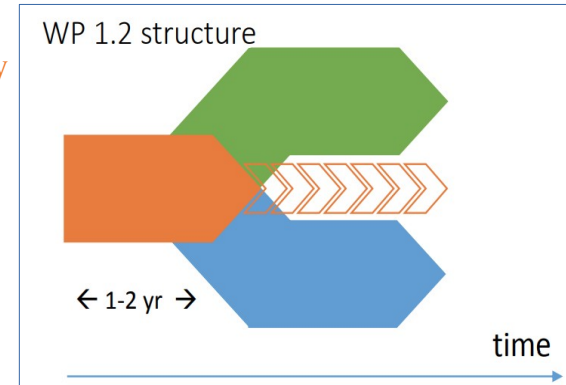

## Transistor test structures (65 nm)

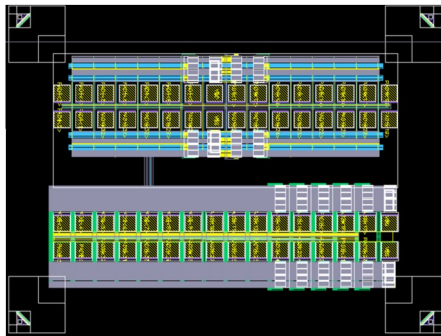

## Simulation: fast analog buffer

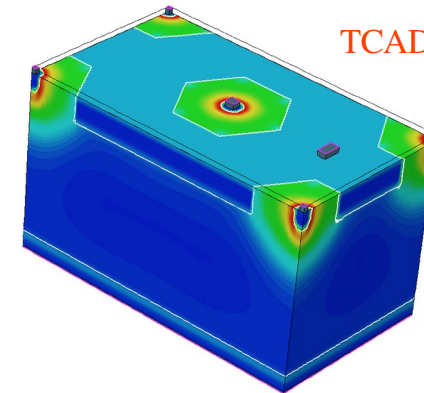
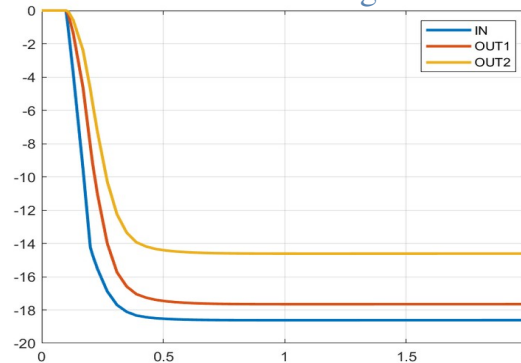

# Review of some ongoing R&D activities/project

## › Silicon Modules

- › This activity focusses on the **study and development of new modules for hybrid **and** CMOS pixel detectors.**
- › **Integrated module assembly** techniques for **large area** CMOS modules and compact hybrid modules.

**Interconnection techniques:** Several activities on CMOS and hybrid pixel modules using different interconnection techniques ongoing at the moment.

- › Chip-2-chip connections – exploring known and alternative interconnection techniques (wire bonding, ACF, Cu-studs,..) to build large area modules with low material budget
- › Anisotropic Conductive Film (ACF) as interconnection alternative to fine pitch bump bonding

**Post processing studies on dicing and thinning:** Studying dicing techniques to reduce insensitive edge regions.

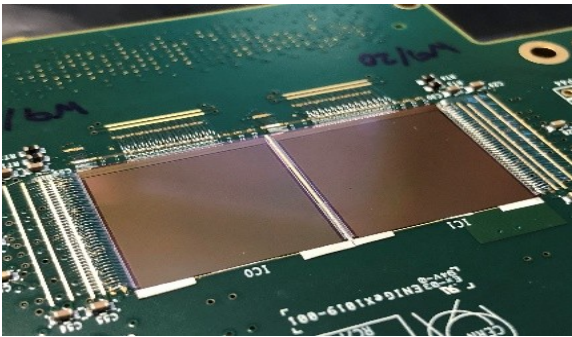

Chip-2-chip data transfer via wire bond

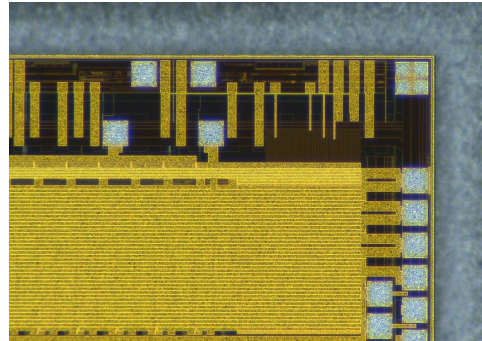

Laser dicing of CMOS sensors (disco.com)

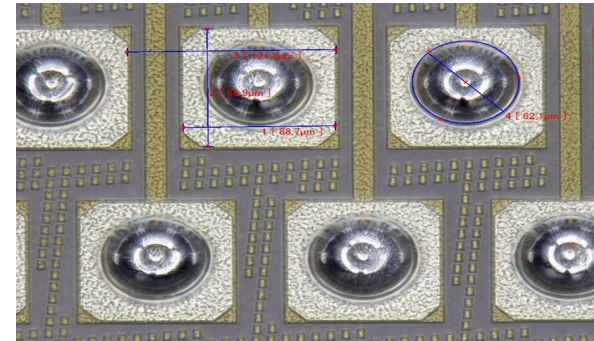

Cu pillars on MALTA (pactech.com)

# Review of some ongoing R&D activities/project

## Simulation and Characterization

- Enabling a fundamental understanding and optimization of the performance of particle detectors.
- Increasingly complex sensors and readout ASICs require improved characterization, modelling and simulation, including radiation effects.

## Low Gain Avalanche Detectors (LGADs)

- Studies on timing performance of thin LGADs after proton irradiation up to a fluence of  $3E15$  neq/cm<sup>2</sup>.
- Evaluation of the gain degradation with IR laser, using the Transient Current Technique (TCT).
- Dedicated timing measurements with IR laser to evaluate their timing capabilities and their operation stability based on the noise level.

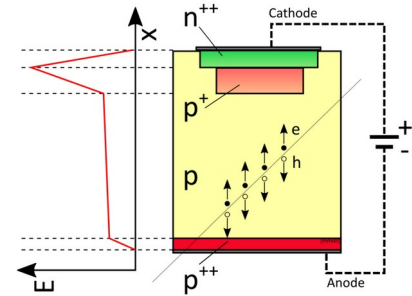

LGAD schematic

Significant presence of “popcorn noise” in the signal implying after this point a **high degradation of the timing performance**.

Best time resolution and limit for the operation stability → For this case:  $\sim 325$  V and **22.7 ps**

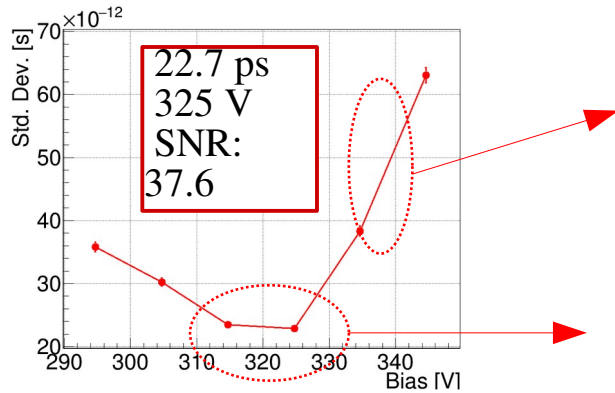

50 um LGAD irradiated to  $1E14$  n<sub>eq</sub>/cm<sup>2</sup>

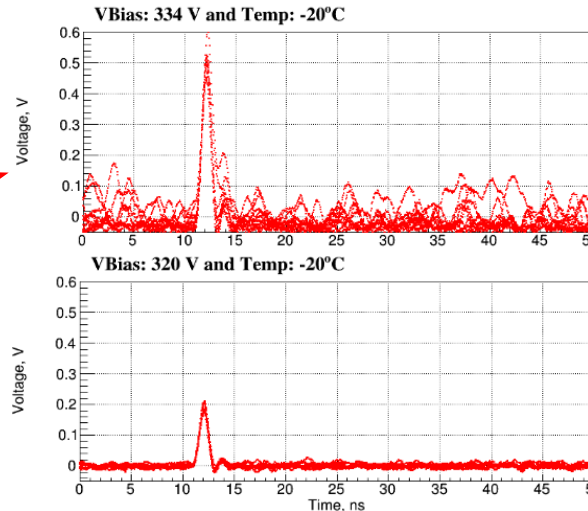

# Review of some ongoing R&D activities/project

## Acceptor removal & Defect Characterization

- **Acceptor removal:** Radiation induced de-activation of acceptors (p-type doping, Boron)
  - Impact:
    - Change of silicon conductivity; Change of sensor depletion voltage and/or active volume
    - Loss of gain in LGAD sensors, sets radiation hardness limits for timing detectors (ETL, HGTD)
  - Microscopic origin: Formation of defects containing Boron that no longer acts as shallow dopant

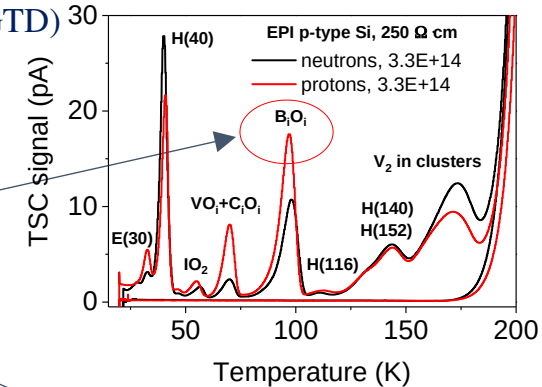

- Aim: Characterize all defects (defect engineering, damage modelling and TCAD simulations)
- Status of the “Acceptor removal project”
  - Test structures (p-type silicon) produced and irradiated
  - Acceptor removal parametrized over 6 orders of magnitude in resistivity (p-type sensors, LGAD)
  - Measured defect concentrations do not fully explain the macroscopic observations!
- Collaborators: CERN, Hamburg Uni, NIMP Bucharest, CIS Erfurt, Uni Minsk

new Boron related defect detected?

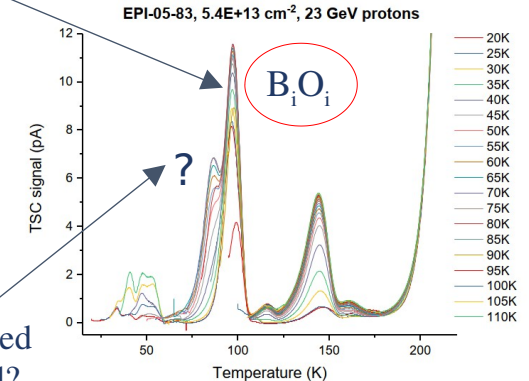

# Review of some ongoing R&D activities/project

## TPA – TCT: Two Photon Absorption – Transient Current Technique

Characterization of un-/irradiated silicon detectors with strong focusing of fs-laser pulses

Advantage of TPA: – charge generation only at focal point – very good spatial resolution – 3D mapping of sensor

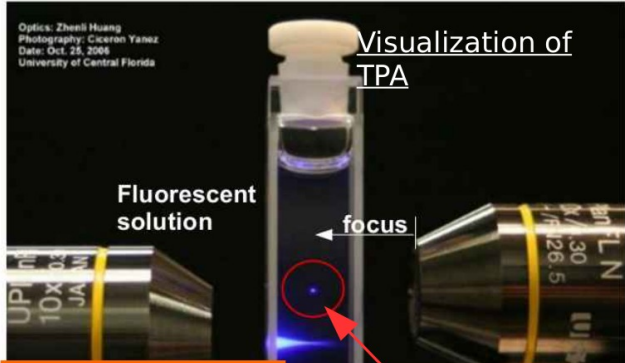

**Single Photon Absorption**  
Energy deposition along beam

**Two Photon Absorption**  
Absorption only at focal point

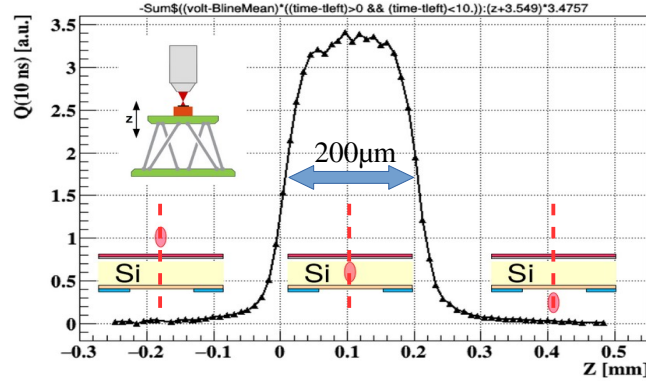

### HVCMS sensor

100 mm x 100 mm; 10 mm depleted;  
Imaged by edge-TCT (left) and TPA-TCT (right)

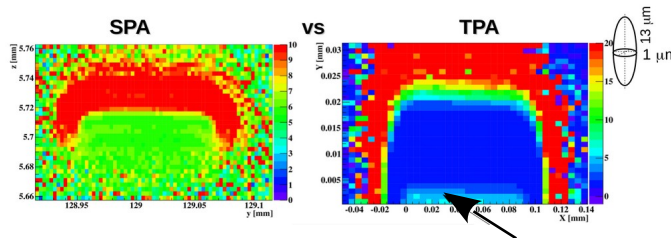

deep n-well in HVCMS - Not resolved in SPA-TCT

Charge carrier density profile

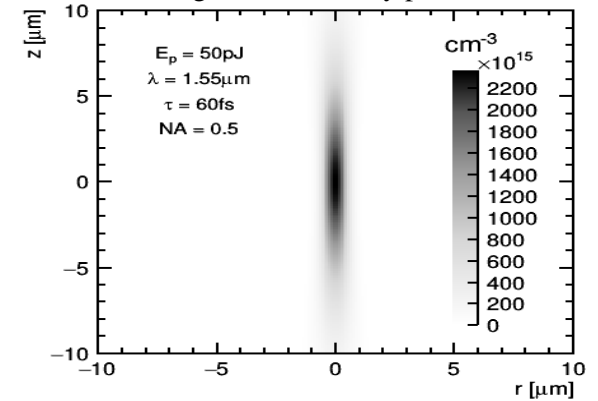

- Resolving sensor properties along beam direction is only possible with TPA
- Resolution perpendicular to beam  $\sim 1\text{-}2\mu\text{m}$
- Irradiated detectors tested:
  - defects induce SPA –Single Photon Absorption; correction methods have been developed
- It is planned to use setup also for SEU testing

- After 2 years of preparations, we have launched an R&D program on detector technologies.
- This effort is very much in the tradition of the White Paper R&D (2008-2011) which was crucial for LHC phase-I and phase-II upgrades.
- Many teams from the CERN user community involved. Even more will join when AIDAInnova will be approved.
- Program (initially) a bit de-scoped to match the budget but additional resources will be looked for.
- First fellows and students have taken up their work. Activities and initial output in all work packages, with some delays due to COVID-19.

## Thank you for your attention !