

Search for jet-induced diffusion wake in Z/γ -jets in heavy-ion collisions



Wei Chen(UCAS)

APRIL 4-10, 2022, KRAKÓW, POLAND
(Online)

Chen, Yang, He, Pang, Wang, Phys.Rev.Lett. 127 (2021) 8, 082301

Yang, Luo, Chen, Pang, Wang, arXiv:2203.03683

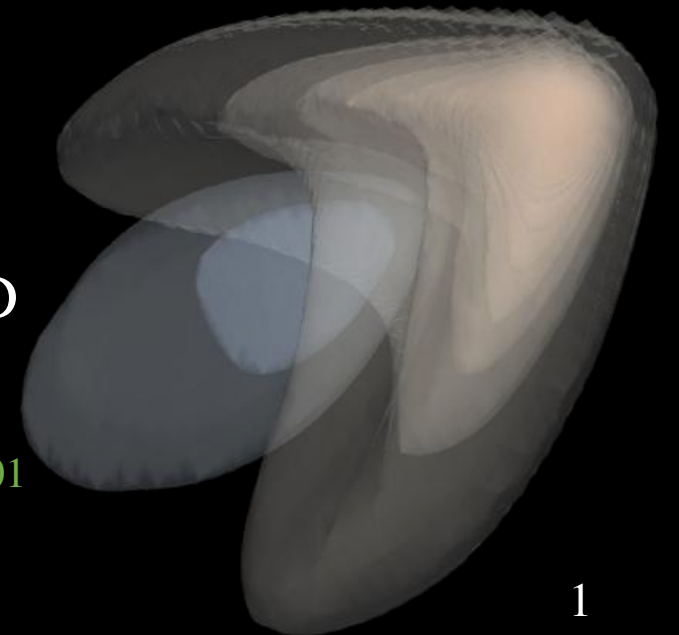

Jet quenching

- ❑ Experimental discovery of jet quenching at Relativistic Heavy-ion Collider (RHIC) provides important evidence for the formation of strongly coupled quark-gluon plasma (QGP)
- ❑ Jet quenching is a powerful tool for the study of QGP properties.
 - It leads to suppression of leading hadrons, dihadron and γ -hadron correlations.
 - It also modifies jet spectra, dijet and γ -jet correlations, jet profiles and jet fragmentation functions.

Jet-induced medium response

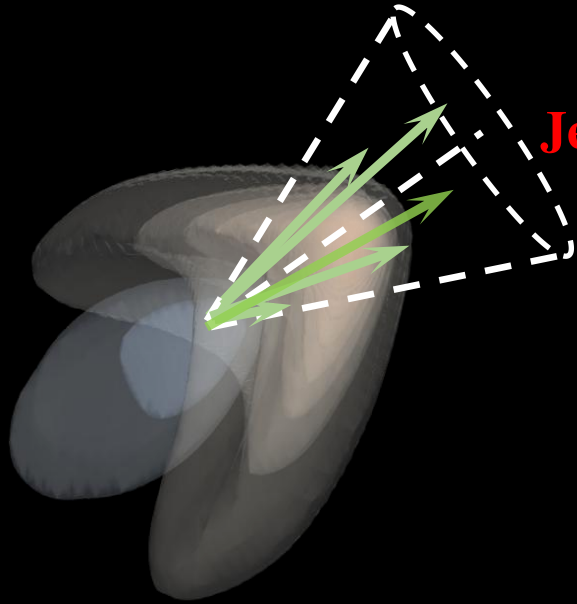

Jets

- Since jets are reconstructed from collimated cluster of hadrons within a jet cone, the final jet modification is determined by:
 - Energy loss of the leading jet show partons
 - How the lost energy is redistributed in the evolving medium.
- The continuous deposition of the lost energy-momentum from jet will induce medium response in the form of Mach-Cone-like excitation. It will
 - transform to soft hadrons in large region.
 - partially within jet cone contribute to the final reconstructed jet.

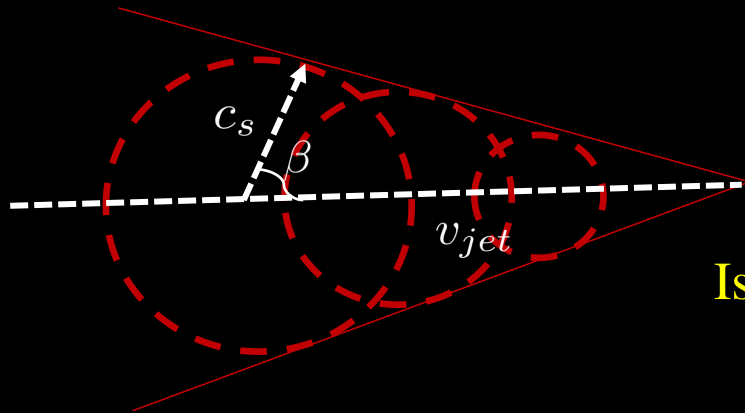

Isolation and detailed study of the medium response are therefore:

- fundamental to fully understand jet quenching phenomena.
- crucial for using them to extract bulk properties of the QGP.

CoLBT-hydro model

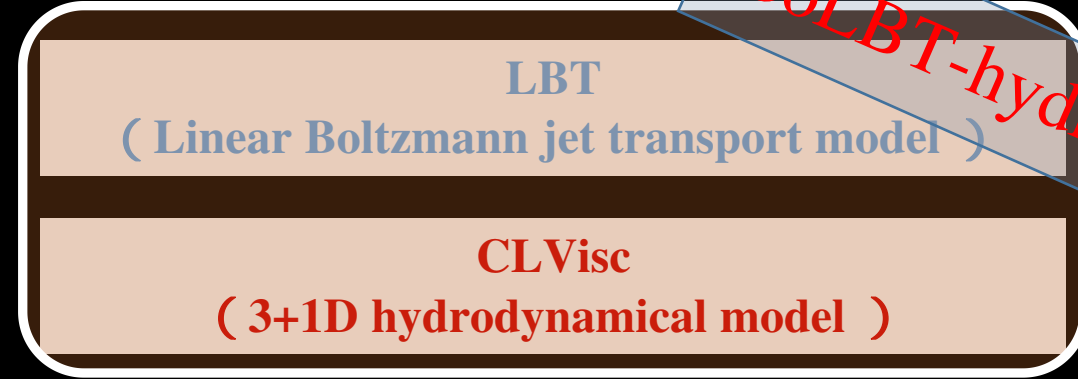
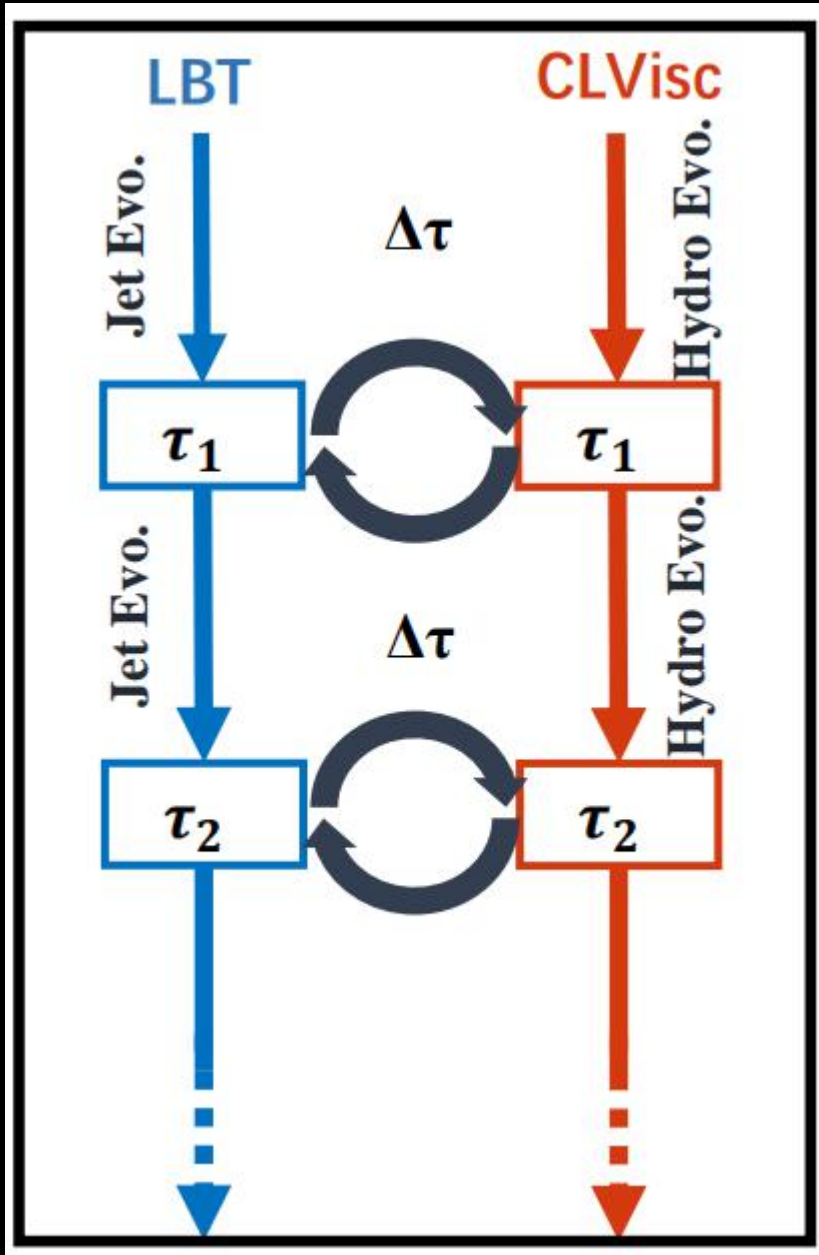

CoLBT-hydro model

CoLBT-hydro model can concurrently describe:

- Space-time evolution of hot-dense medium (CLVisc)
- Jet propagation and transport(LBT)
- Jet-induced medium response in the process of jet-medium interaction in real time.

CoLBT-hydro model

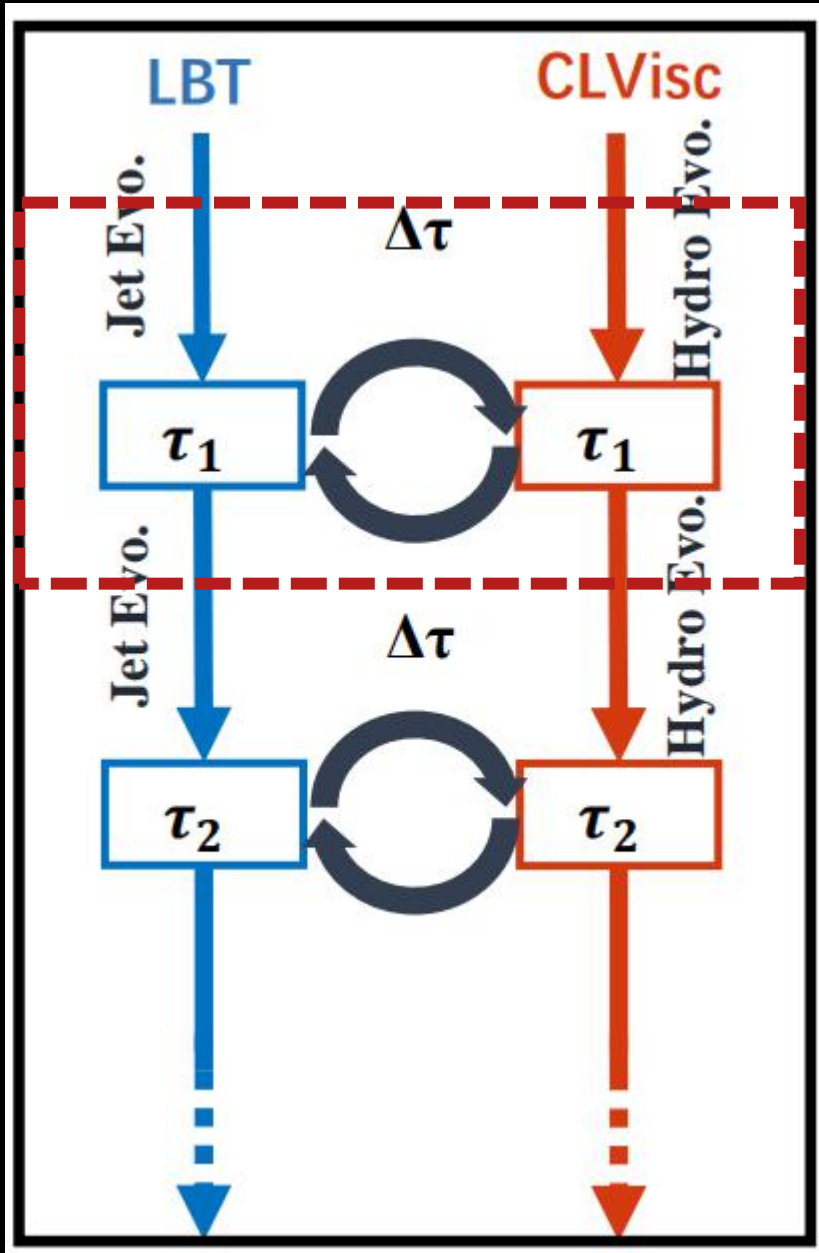

How to describe the interaction between jet partons and medium?

At each time interval:

1. Carry out jet partons transport according to the surrounding medium info
2. Sort jet partons according to a cut-off parameter p_{cut}^0
 - hard partons $p \cdot u > p_{cut}^0$
 - soft and negative partons. $p \cdot u < p_{cut}^0$
3. Update medium information by solving the hydrodynamic equations with source term.

$$\nabla_{\mu} T^{\mu\nu} = J^{\nu}$$

until the end of hydro evolution.

Jet observables related to jet-induced medium response

- Jet substructure observables are considered to be sensitive to the jet-induced medium response.
- We focus on the study of jet fragmentation function and jet profiles to investigate the medium response effect and search for its signal.

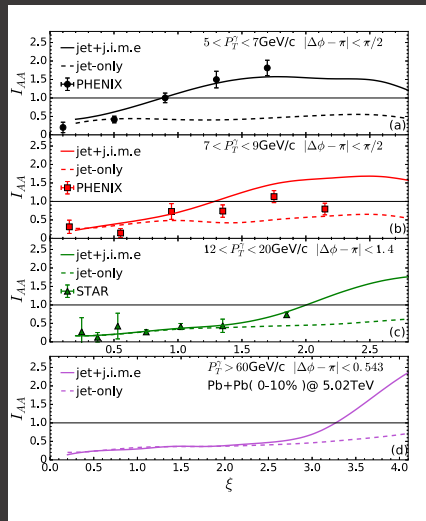

Chen et al, PLB777(2018)86

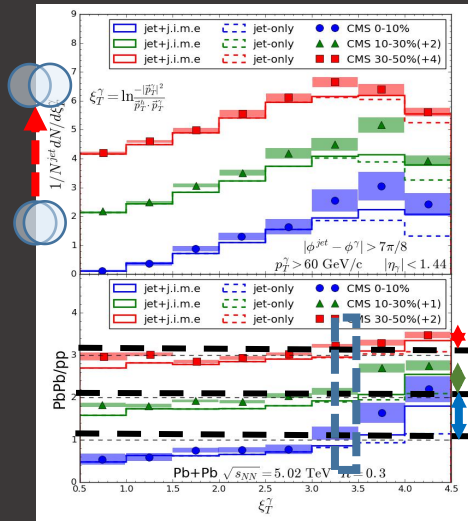

Chen et al, PLB 810 (2020) 135783

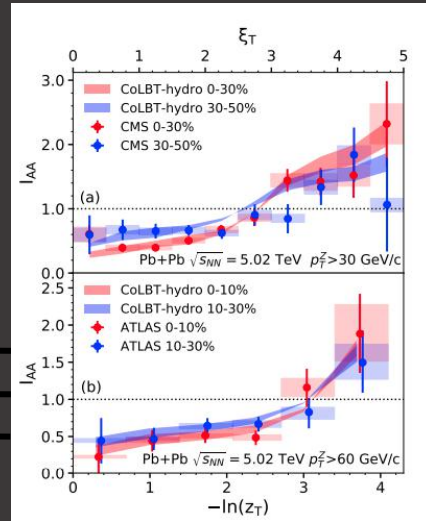

Chen et al, PRL. 127 (2021) 8, 082301

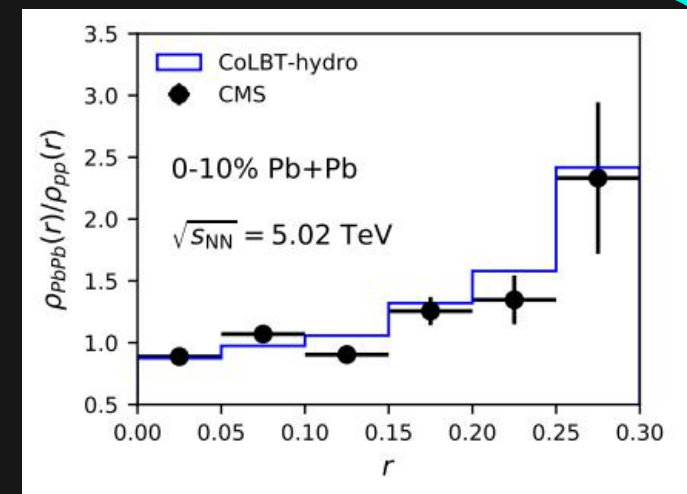

Yang et al, arXiv:2203.03683

- Main features:**
- Suppression of hadrons at small ξ (large z)
 - Enhancement of hadrons at large ξ (small z)
 - Enhancement of soft hadrons at large radius.

← jet energy loss

← jet-induced medium response

Medium response & soft gluon radiation

- The enhancement of soft hadrons yield is also contributed from medium-induced soft gluon radiations.
- The energy scale $\omega \sim T$ for radiative gluons induced by jet-medium interaction is also similar to that from the jet-induced medium response.

Medium response: $\delta f(p) \sim e^{-p \cdot u/T}$ Energy scale: $\omega \sim T$

Soft radiated gluons: $\omega_g \sim \hat{q}\lambda^2 \sim T$

We can't distinguish them according to the experimental observables.

We should search for unambiguous signatures of medium response without any similar competing effect.

Jet-induced diffusion wake

□ The jet-induced medium response consists of not only the wave front but also the diffusion wake.

Microscopically, each jet medium interaction kicks the medium parton into a recoil particle and leaves behind a “particle-hole”.

- Transport of the recoil particles forms the wave front.
- The diffusion of the “particle-holes” leads to the diffusion wake.

□ The diffusion wake leads to a depletion of soft hadrons in the back direction of the jet and, therefore, is an unambiguous signal of the jet-induced medium excitation.

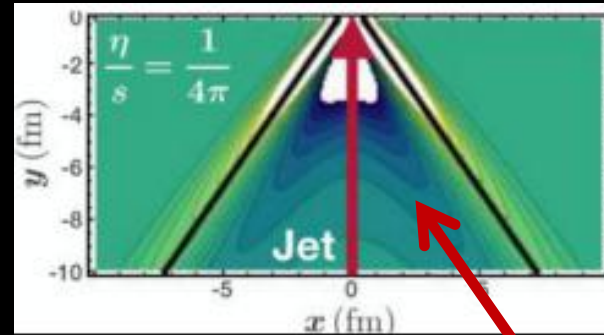

R.B.Neufeld. PRC79,054909(09')

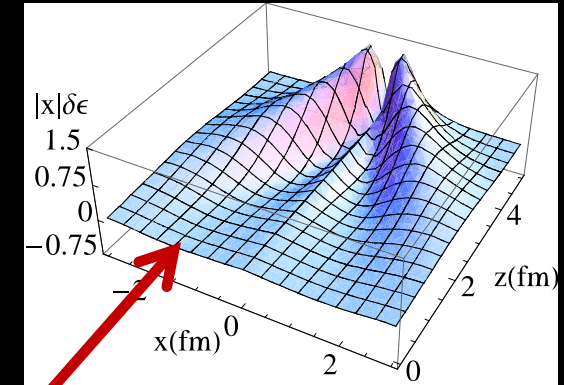

Qin, Majumder, Song & Heinz (08)

diffusion wake

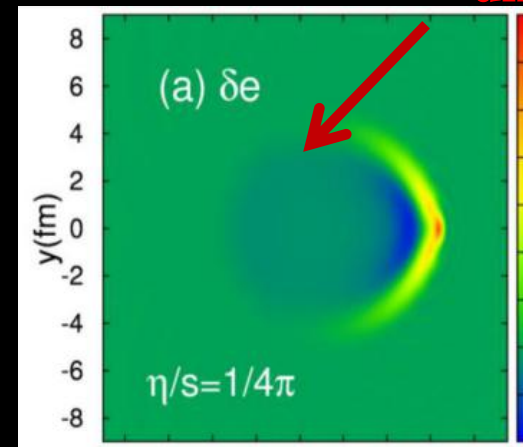

Yan Li ,S,Jeon and C.Gale(17)

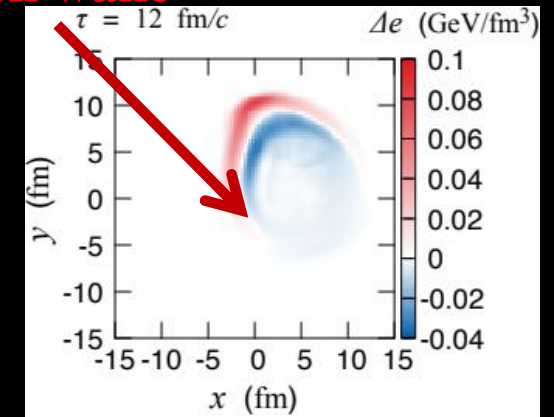

Tachibana, Chang, Qin, PRC 95 (1017) 4, 044909

The signals of diffusion wake at RHIC energy

Azimuthal angle distribution of associated hadrons yield

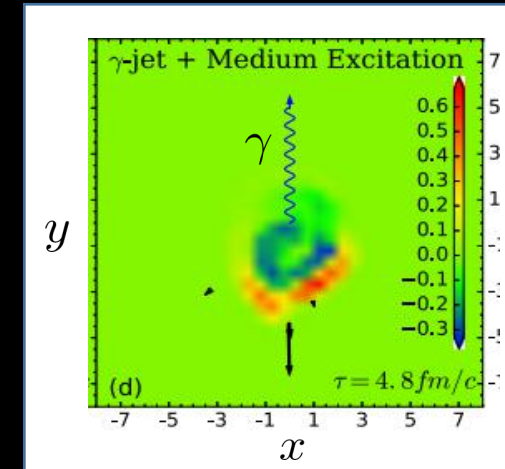
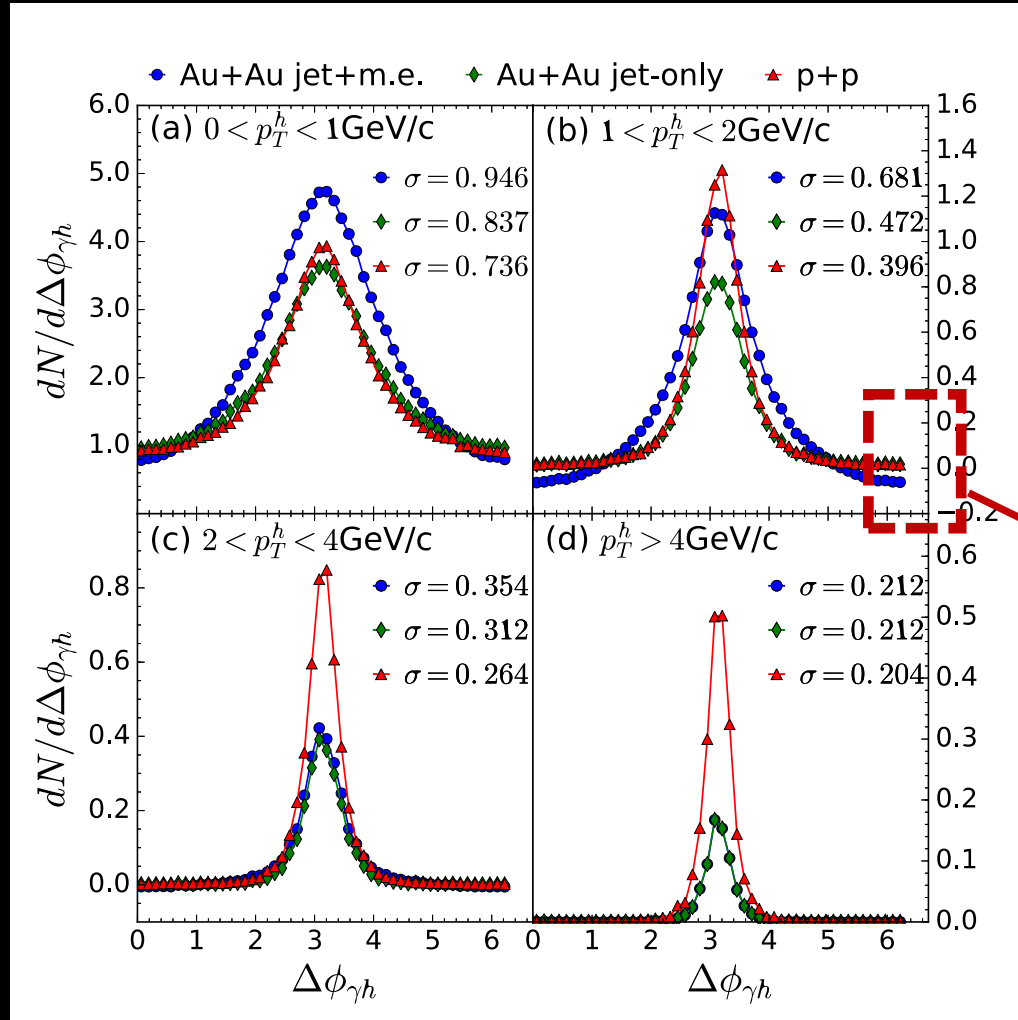

The signal of jet-induced diffusion wake:

The depletion of soft hadrons in the γ direction in

$1 < p_T^h < 2 \text{ GeV}/c$.

$$\Delta\phi_{\gamma h} = \phi_h - \phi_\gamma \quad \text{let } \phi_\gamma = 0$$

No signals of diffusion wake at LHC energy?

□ The more obvious depletion in azimuthal angle distribution is expected at LHC energy.

- Larger jet p_T
- more strongly interacting medium

□ However, CMS show an enhanced soft hadron yield in the Z direction in Pb+Pb collisions.

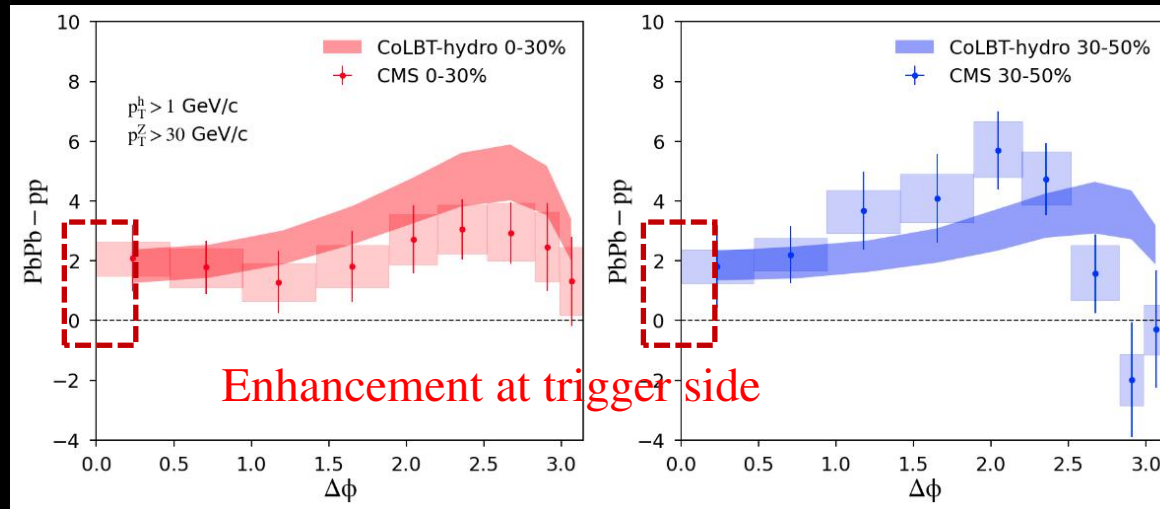

□ CoLBT-hydro results agree with CMS data.

The effect of Multiple Parton Interaction(MPI)

- ❑ All particles produced in the same p+p collision as the triggered Z boson are signal.
- ❑ Non-zero hadron yield in Z direction comes mainly from MPI associated with a triggered hard process.
- ❑ Multiple minijet production will be enhanced in triggered jet events with increasing collision energy and trigger jet pt region.

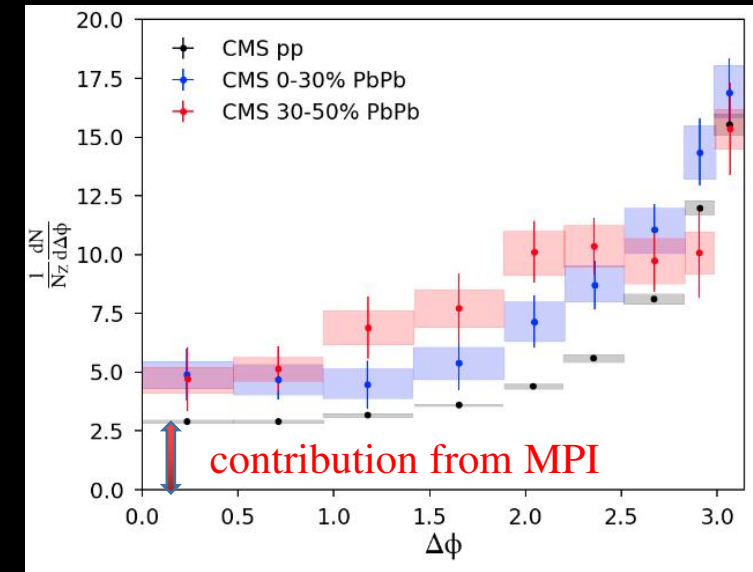

Interaction of these minijets from MPI with the medium will lead to an enhancement of soft hadrons, which covers up the signal of diffusion wake.

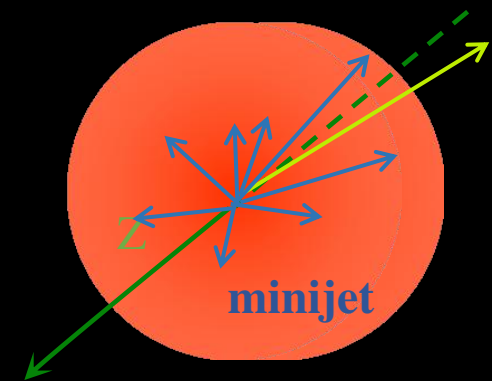

MPI subtraction in Z-hadron correlation

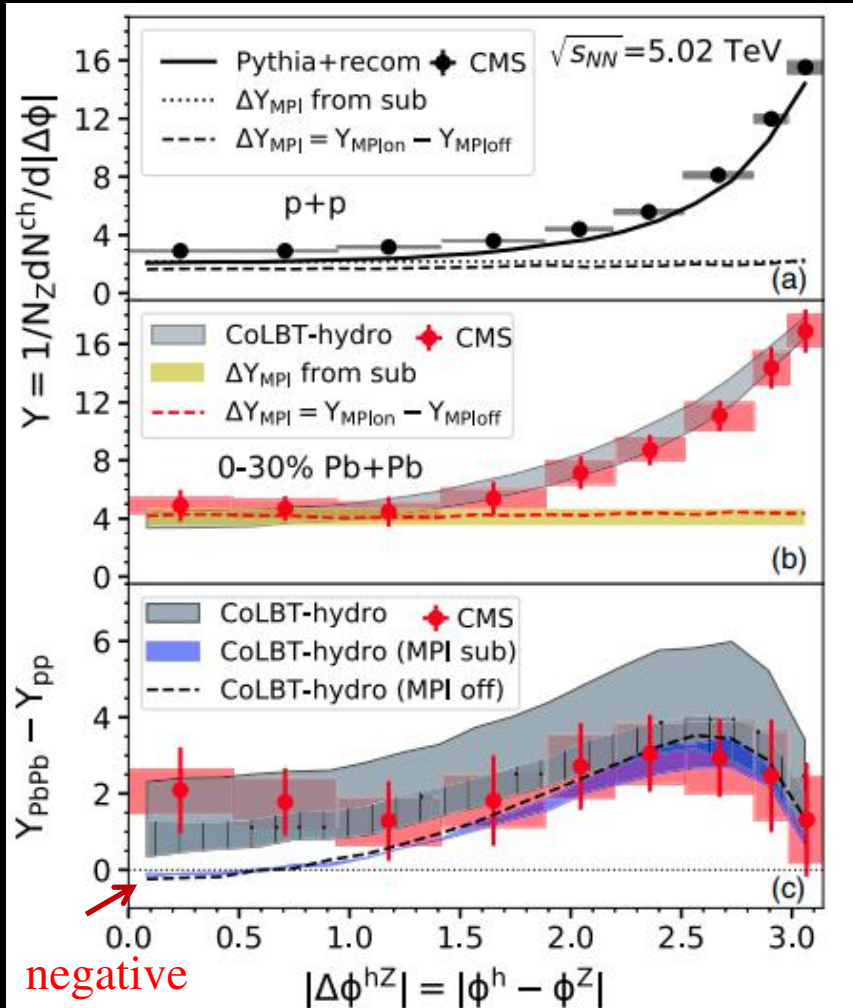

- To search for signals of the jet-induced diffusion wake, we devise a procedure to subtract the MPI's contribution

$$\frac{dN_{MPI}^{hZ}}{d\phi} = \frac{dN_{mix}^{hZ}}{d\phi} - \int_1^\pi \frac{d\phi}{\pi} \left(\frac{dN^{hZ}}{d\phi} - \frac{dN^{hZ}}{d\phi} \Big|_{\phi=1} \right)$$

- A signal of the jet-induced diffusion wake similar to the γ -hadron correlation at RHIC after the subtraction of the MPI contribution.
- Comparison to the medium modification without MPI (dashed) shows that the subtraction procedure works well.

2D jet tomography

To make the effect of diffusion wake enhanced, we select the specific events using 2D jet tomography

□ Longitudinal jet tomography:

Select the small value of the γ -jet momentum asymmetry to bias toward longer jet propagation length

$$z_T = p^h / p^\gamma$$

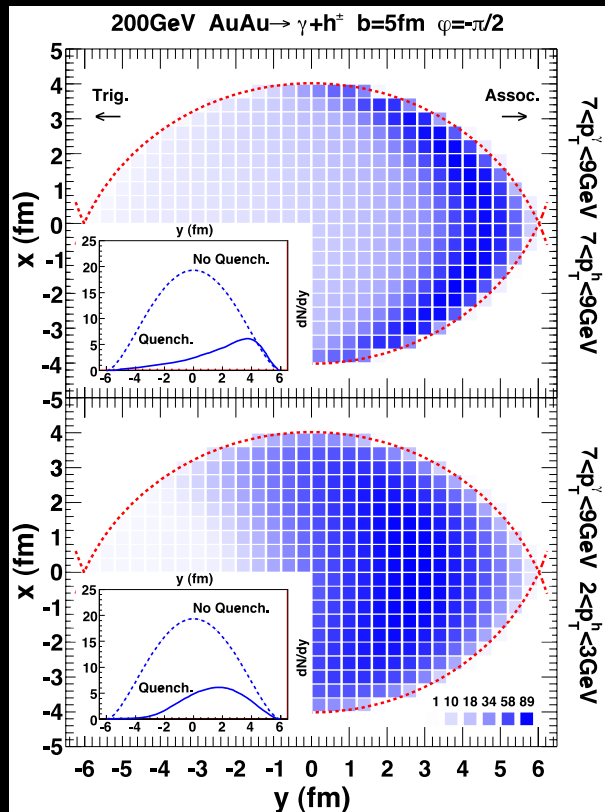

$z_T \sim 1$ mainly from surface emission

$z_T \sim 0.3$ mainly from volume emission

Zhang, Owens, Wang and XNW, Phys. Rev. Lett. 103, 032302(2009)

2D jet tomography

□ Transverse gradient jet tomography:

Select the value of the transverse asymmetry to localize the transverse production position of the initial jet.

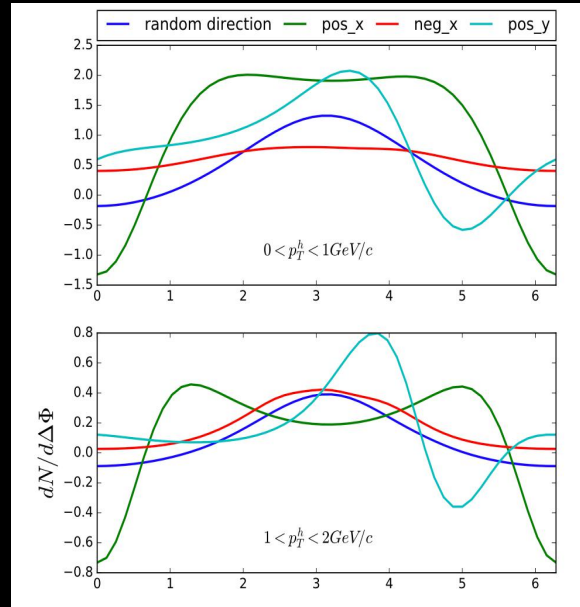

transverse asymmetry

$$A_{\vec{n}} = \frac{\int d\phi [(dN^h/d\phi)_{\phi-\phi_n > 0} - (dN^h/d\phi)_{\phi-\phi_n < 0}]}{\int d\phi dN^h/d\phi}$$

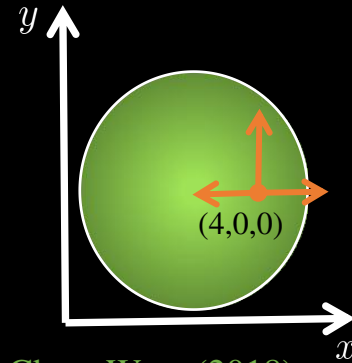

Chen, Wang(2018)

different angular structure of jet-induced medium response when fixing initial position and jet direction

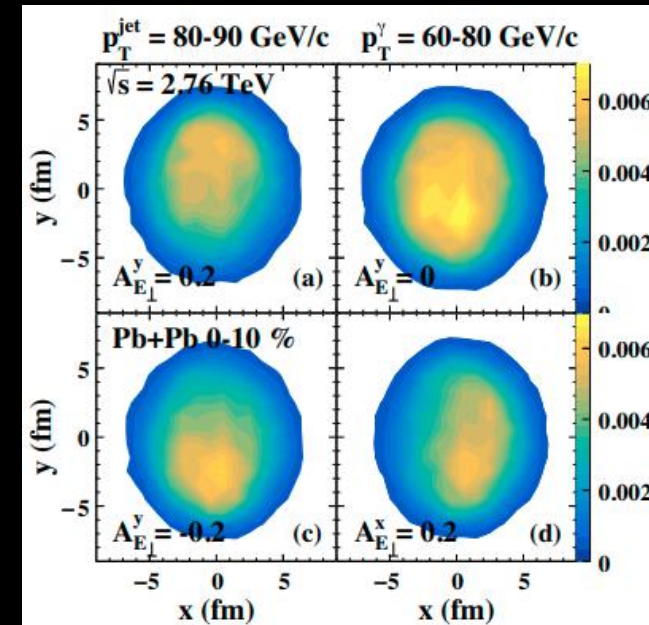

Ya yun's talk in jets section, Apr 6

Enhanced diffusion wake effect

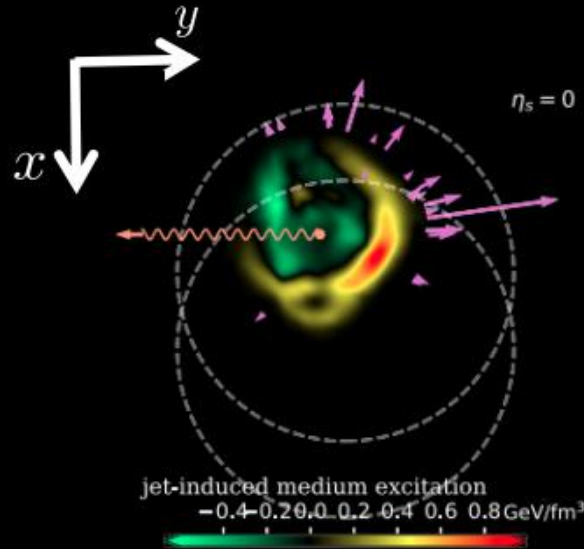
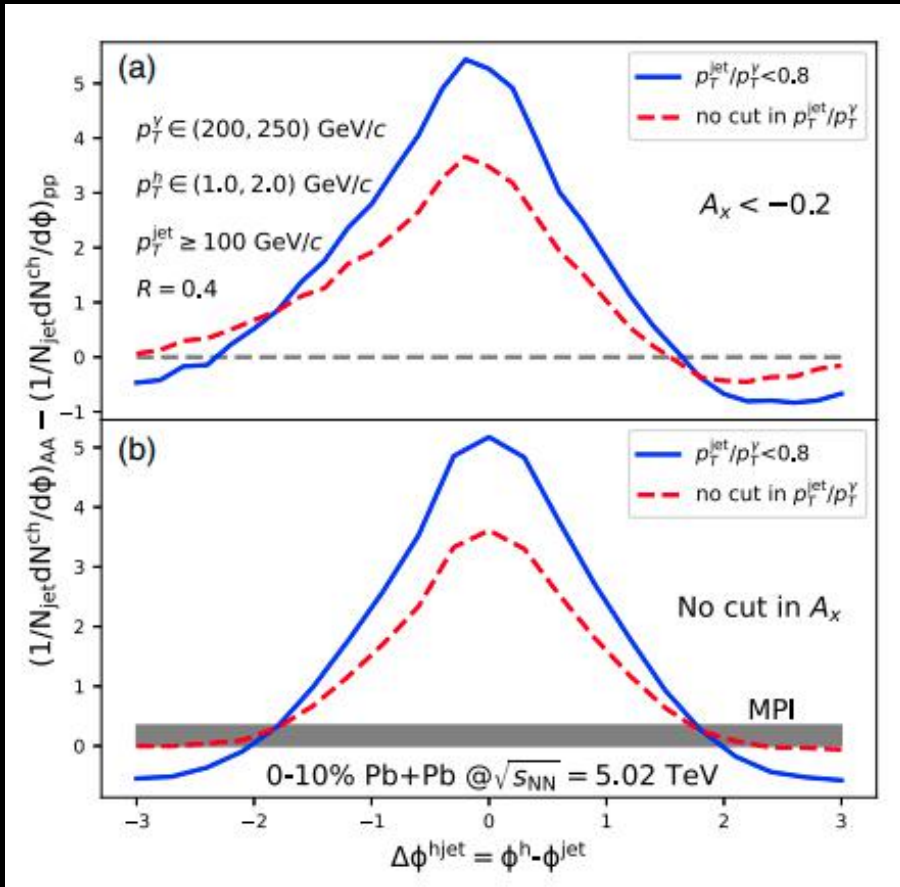

- The asymmetric features and the diffusion wake are clearly seen even without subtraction of the MPI background.
- Enhanced soft hadrons in jet direction as well as soft hadron depletion in the γ direction in

Chen, Yang, He, Pang, Wang, Phys.Rev.Lett. 127 (2021) 8, 082301

3D structure of diffusion wake

Jet hadron correlation

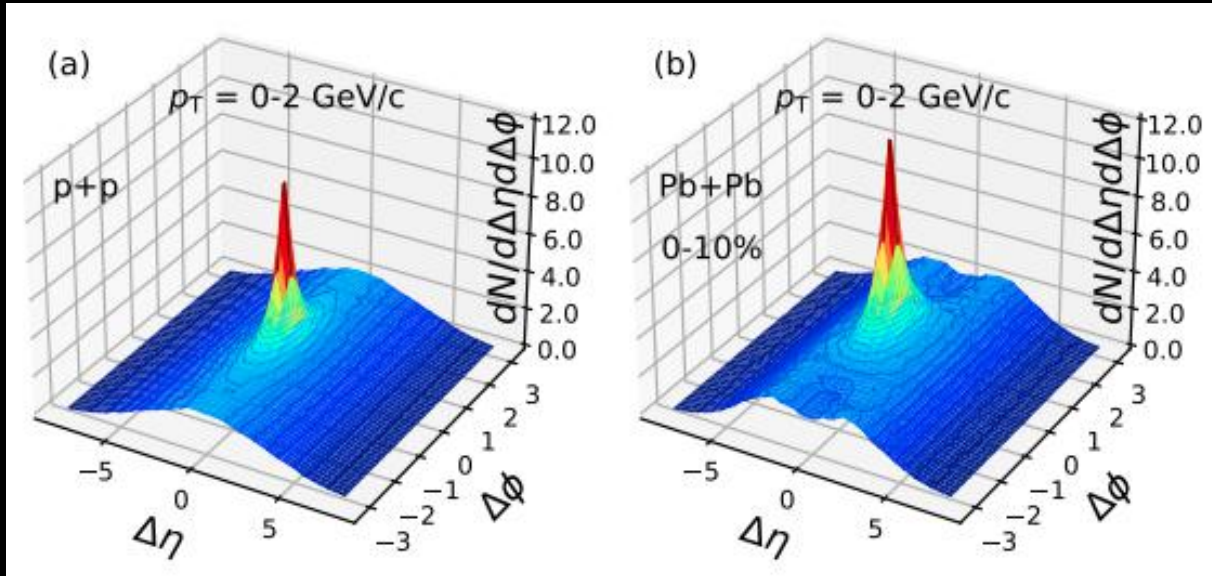

$$\Delta\eta = \eta_h - \eta_{jet} \quad \Delta\phi = \phi_h - \phi_{jet}$$

Yang, Luo, Chen, Pang, Wang, arXiv:2203.03683

3D structure of jet-induced medium response:

□ In p-p collision:

- A jet peak on the top of a ridge along azimuthal angle from MPI

□ In Pb-Pb collision:

- Enhanced jet peak due to medium modification.
- A valley is formed on top of the MPI ridge due to the depletion of soft hadrons by jet-induced diffusion wake.

The structure of this valley in rapidity $\Delta\eta$ as a unique signal of the diffusion wake without subtraction of MPI background

A 2-Gaussian fit method

Jet hadron correlation

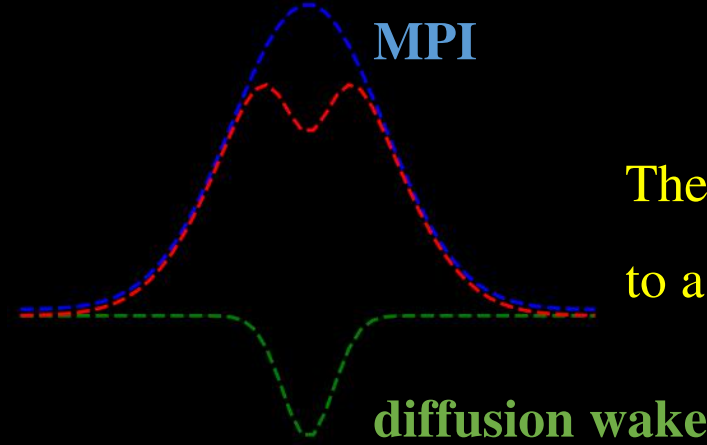
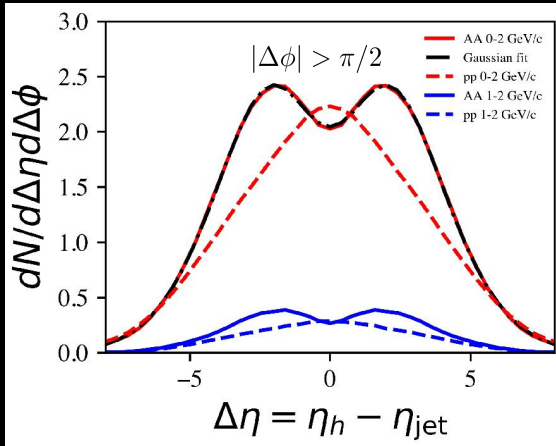

The DF-wake valley on top of the MPI ridge gives rise to a double peak feature.

diffusion wake

MPI

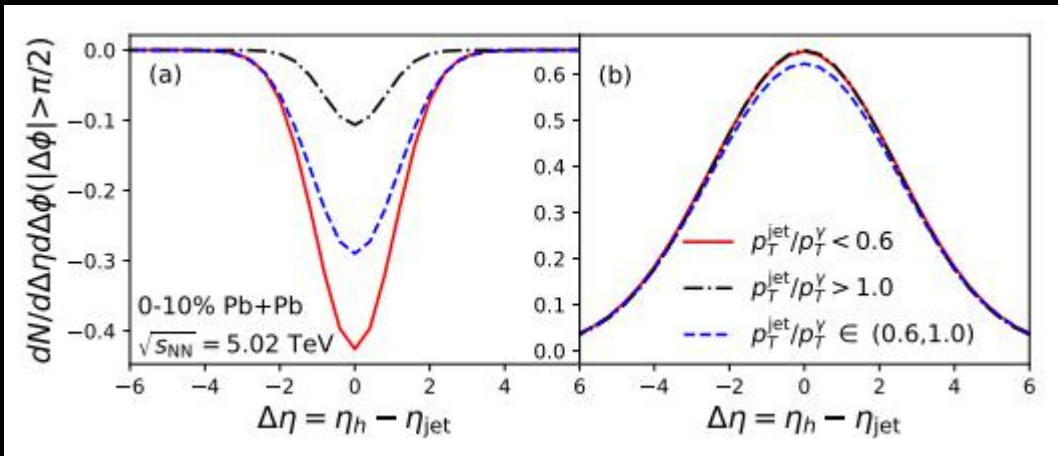

A 2-Gaussian fit method is used to separate the DF-wake valley and MPI ridge in the jet-hadron correlation.

diffusion wake MPI

$$F(\Delta\eta) = \int_{\eta_{j1}}^{\eta_{j2}} d\eta_j F_3(\eta_j) (F_1(\Delta\eta) + F_2(\Delta\eta, \eta_j))$$

jet rapidity distribution

$$\Delta\eta = \eta_h - \eta_{jet} \quad \Delta\phi = \phi_h - \phi_{jet}$$

Summary

□ We have investigated Z/γ hadron correlation in high-energy heavy-ion collisions within the CoLBT-hydro model in search for the signal of jet-induced diffusion wake.

- A depletion of soft hadrons at Z/γ direction as a signal of jet-induced diffusion wake can be seen after the subtraction of MPI contribution.
- 2D jet tomography method can be used to enhance the signal of jet-induced diffusion wake.

□ We explore the 3D structure of the diffusion wake in γ -jet events.

- The valley in rapidity $\Delta\eta$ caused by the diffusion wake while the ridge is mostly due to soft hadrons from MPI.
- The diffusion wake valley and MPI ridge can be extracted by a 2-Gaussian fit method.
- We check the sensitivity of the medium response on the shear viscosity and EOS by the diffusion wake valley and MPI ridge. Yang's poster, T04_1 Apr 7