



Supported in part by
U.S. DEPARTMENT OF
ENERGY | Office of
Science

Study of Charge Symmetry Breaking in $A = 4$ hypernuclei in

$\sqrt{s_{NN}} = 3$ GeV Au+Au collisions at RHIC

Tianhao Shao (邵天浩)

For the STAR Collaboration

Fudan University

**HYP
2022
PRAGUE**

14th International Conference on Hypernuclear and Strange Particle Physics
Prague, Czech Republic
June 27 – July 1, 2022



- Motivation
- STAR fixed target program
- Particle identification and signal reconstruction
- Corrections and systematic uncertainties
- Λ binding energy
- Charge symmetry breaking
- Summary

Motivation - Experimental studies



M. Juric et. al., Nuclear Physics A 754 (2005) 3c–13c

Nuclear emulsion experiment in 1970s

| Hypernuclide | B_Λ / MeV |
|-------------------------|-------------------|
| ${}^3_\Lambda\text{H}$ | 0.13 ± 0.05 |
| ${}^4_\Lambda\text{H}$ | 2.04 ± 0.04 |
| ${}^4_\Lambda\text{He}$ | 2.39 ± 0.03 |

$$\Delta B_\Lambda (\text{g.s.}) = B_\Lambda ({}^4_\Lambda\text{H})_{\text{g.s.}} - B_\Lambda ({}^4_\Lambda\text{He})_{\text{g.s.}} = 350 \pm 60 \text{ keV}$$

$$\Delta B_\Lambda (\text{exc}) = B_\Lambda ({}^4_\Lambda\text{H})_{\text{exc}} - B_\Lambda ({}^4_\Lambda\text{He})_{\text{exc}} = 30 \pm 50 \text{ keV}$$

- The charge symmetry breaking (CSB) in $A = 4$ hypernuclei shows a large value in ground states while it is quite small in excited states.

J-PARC E13 Collaboration, PRL 115, 222501 (2015)

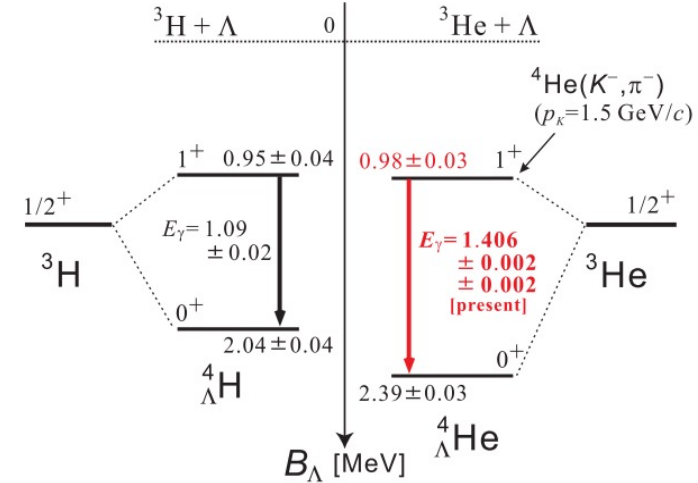

A1 Collaboration, PRL 114, 232501 (2015), NPA 954(2016) 149-160

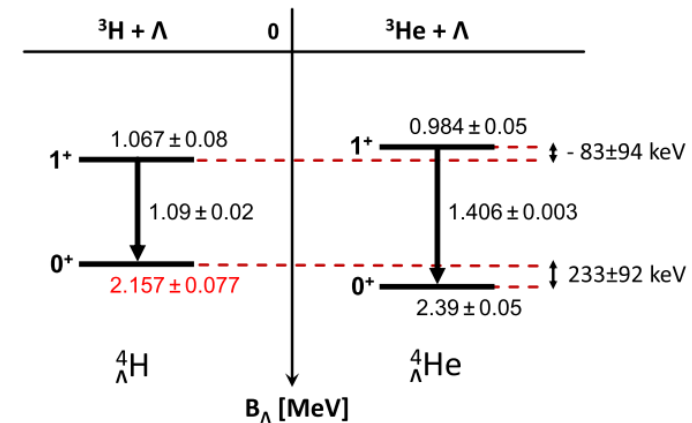

Model calculations

A. Gal, PLB 744 (2015) 352-357

Table 2: Calculated CSB contributions to $\Delta B_{\Lambda}^4(0_{g.s.}^+)$ and total values of $\Delta B_{\Lambda}^4(0_{g.s.}^+)$ and $\Delta B_{\Lambda}^4(1_{exc}^+)$, in keV, from several model calculations of the $A = 4$ hypernuclei. Recall that $\Delta B_{\Lambda}^{exp}(0_{g.s.}^+) = 350 \pm 60$ keV [3].

| ${}^4\text{He}-{}^4\text{H}$ model | $P_{\Sigma}(\%)$ $0_{g.s.}^+$ | ΔT_{YN} $0_{g.s.}^+$ | ΔV_C $0_{g.s.}^+$ | ΔV_{YN} $0_{g.s.}^+$ | ΔB_{Λ}^4 $0_{g.s.}^+$ | ΔB_{Λ}^4 1_{exc}^+ |
|---------------------------------------|----------------------------------|---------------------------------|------------------------------|---------------------------------|--|---------------------------------------|
| ΛNNN [9] | – | – | –42 | 91 | 49 | –61 |
| NSC97 _e [10] | 1.6 | 47 | –16 | 44 | 75 | –10 |
| NSC97 _f [11] | 1.8 | | | | 100 | –10 |
| NLO chiral [12] | 2.1 | 55 | –9 | – | 46 | |
| $(\Lambda\Sigma)_e$ [present] | 0.72 | 39 | –45 | 232 | 226 | 30 |
| $(\Lambda\Sigma)_f$ [present] | 0.92 | 49 | –46 | 263 | 266 | 39 |

keV

- Most of model calculations can not reproduce the experimental results.
- D. Gazda and A. Gal introduced the Λ - Σ^0 mixing in calculation and show that the CSB in ground and excited states **are comparable**.
- Need independent experiments to test.

D. Gazda and A. Gal, PRL 116, 122501 (2016)

PRL 116, 122501 (2016)

PHYSICAL REVIEW LETTERS

week ending
25 MARCH 2016

Ab initio Calculations of Charge Symmetry Breaking in the $A = 4$ Hypernuclei

Daniel Gazda^{1,2,3,*} and Avraham Gal^{4,†}

¹Nuclear Physics Institute, 25068 Řež, Czech Republic

²ECT*, Villa Tambosi, 38123 Villazzano (Trento), Italy

³Department of Fundamental Physics, Chalmers University of Technology, SE-412 96 Göteborg, Sweden

⁴Racah Institute of Physics, The Hebrew University, Jerusalem 91904, Israel

(Received 7 December 2015; published 22 March 2016)

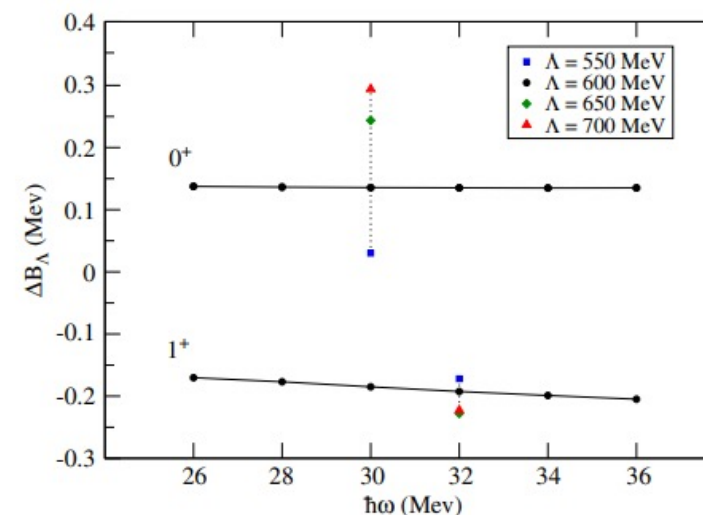

$$\overline{\Delta B_{\Lambda}^{J=1}} \approx -\overline{\Delta B_{\Lambda}^{J=0}} < 0.$$

STAR fixed target program

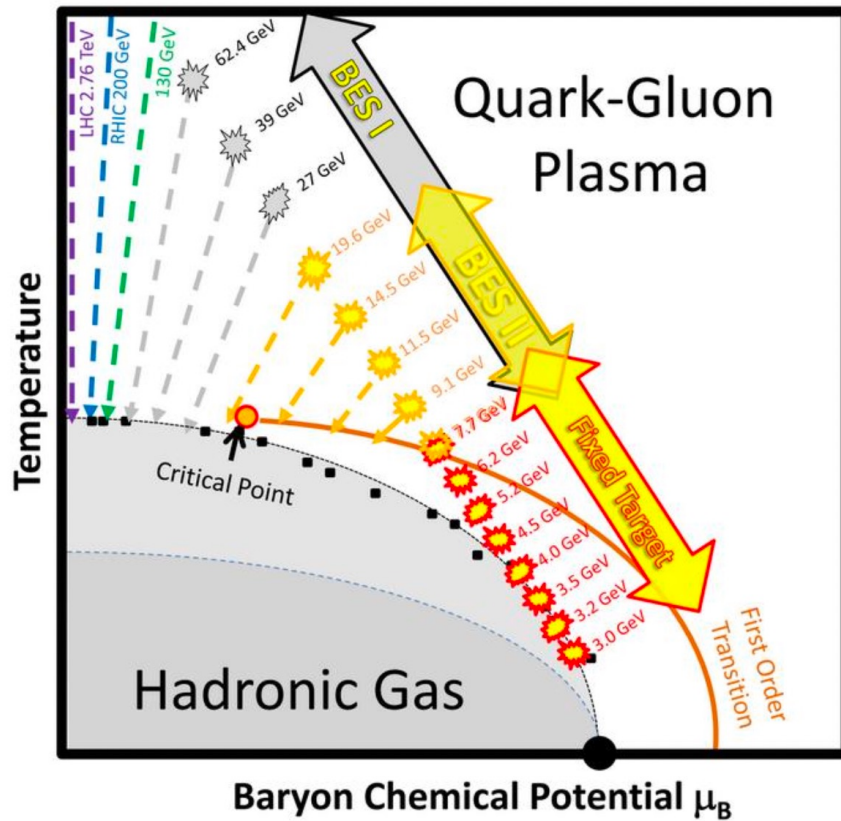

STAR Fixed Target setup

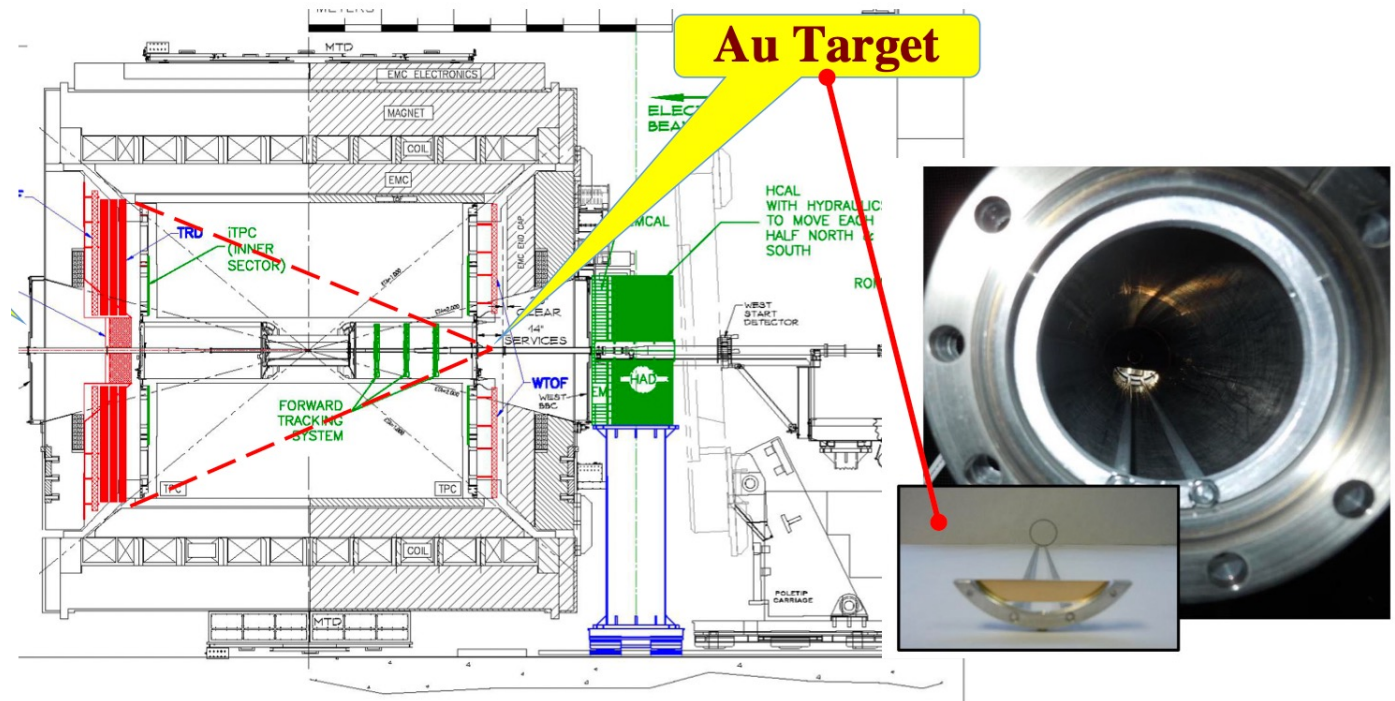

- STAR Au+Au at $\sqrt{s_{NN}} = 3$ GeV FXT run in 2018, ~ 317M events

Charged particle identification

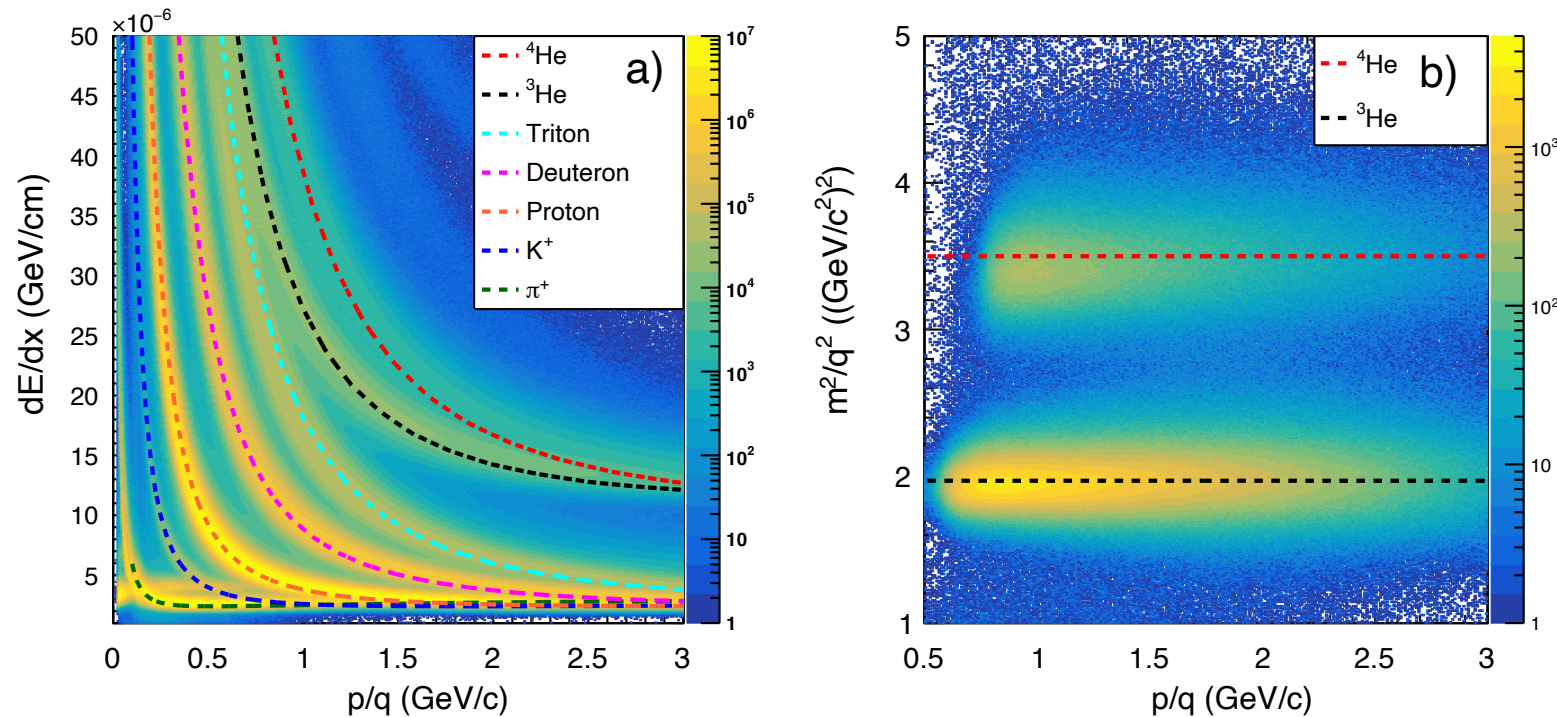

- Charged particle PID is based on the dE/dx from the TPC. ^3He and ^4He are also selected according to the mass square from the TOF.

${}^4_{\Lambda}H$ and ${}^4_{\Lambda}He$ reconstruction

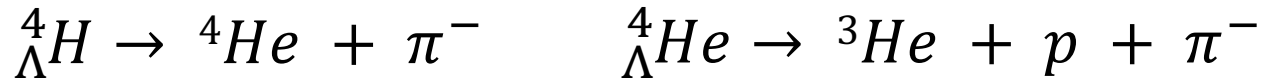

Reconstructed with **KFParticle** package

KFParticle class describes particles by:

$$\mathbf{r} = \{ x, y, z, p_x, p_y, p_z, E \}$$

State vector

$$\mathbf{C} = \langle \mathbf{r} \mathbf{r}^T \rangle =$$

Covariance matrix

$$\begin{bmatrix} \sigma_x^2 & C_{xy} & C_{xz} & C_{xp_x} & C_{xp_y} & C_{xp_z} & C_{xE} \\ C_{xy} & \sigma_y^2 & C_{yz} & C_{yp_x} & C_{yp_y} & C_{yp_z} & C_{yE} \\ C_{xz} & C_{yz} & \sigma_z^2 & C_{zp_x} & C_{zp_y} & C_{zp_z} & C_{zE} \\ C_{xp_x} & C_{yp_x} & C_{zp_x} & \sigma_{p_x}^2 & C_{p_x p_y} & C_{p_x p_z} & C_{p_x E} \\ C_{xp_y} & C_{yp_y} & C_{zp_y} & C_{p_x p_y} & \sigma_{p_y}^2 & C_{p_y p_z} & C_{p_y E} \\ C_{xp_z} & C_{yp_z} & C_{zp_z} & C_{p_x p_z} & C_{p_y p_z} & \sigma_{p_z}^2 & C_{p_z E} \\ C_{xE} & C_{yE} & C_{zE} & C_{p_x E} & C_{p_y E} & C_{p_z E} & \sigma_E^2 \end{bmatrix}$$

- KFParticle package shows a high quality of the reconstructed particles, high efficiencies, and high signal to background ratios.

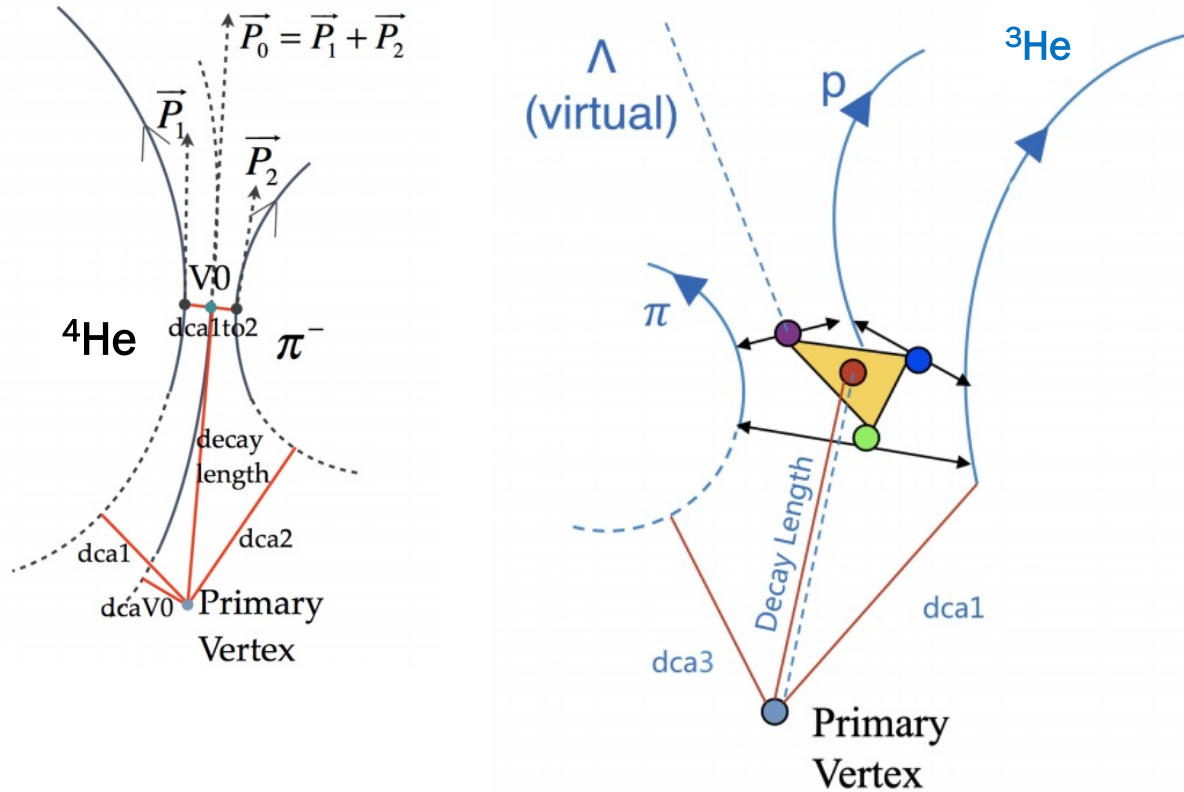

Decay topology of ${}^4_{\Lambda}H$ and ${}^4_{\Lambda}He$.

KFParticle Finder — M. Zyzak, "Online selection of short-lived particles on many-core computer architectures in the CBM experiment at FAIR," Dissertation thesis, Goethe University of Frankfurt, 2016, <http://publikationen.ub.uni-frankfurt.de/frontdoor/index/index/docId/41428>

${}^4_{\Lambda}\text{H}$ and ${}^4_{\Lambda}\text{He}$ reconstruction



- Using TMVA-BDT to optimize the signal.
- Training samples:
 - Signal: MC simulation
 - Background: rotate ${}^4\text{He}$ or ${}^3\text{He}$ track by 180 degrees

${}^4_{\Lambda}\text{H}$

${}^4_{\Lambda}\text{He}$

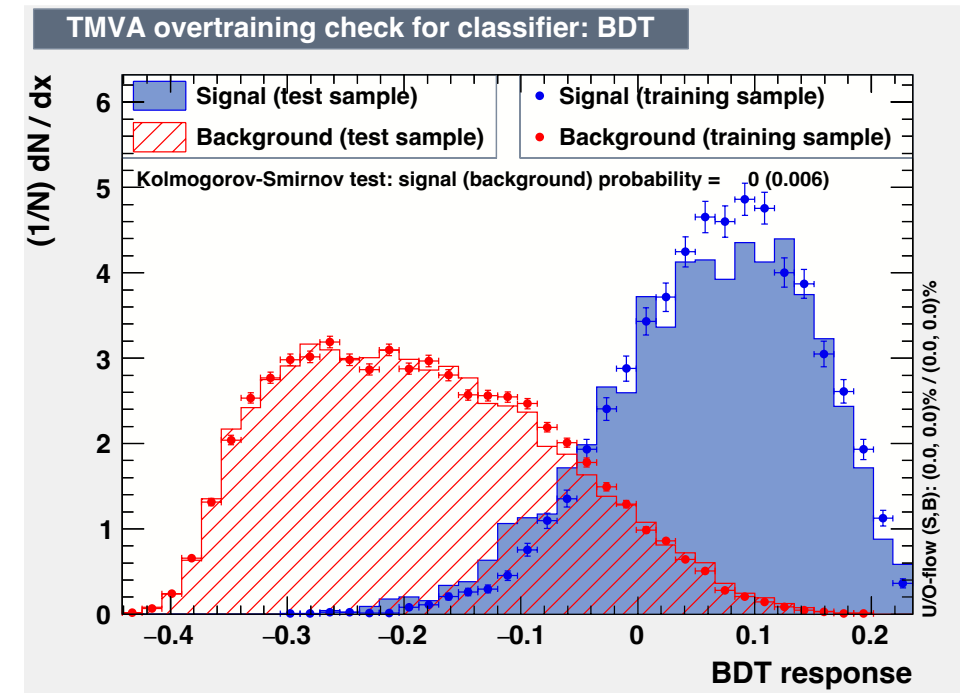
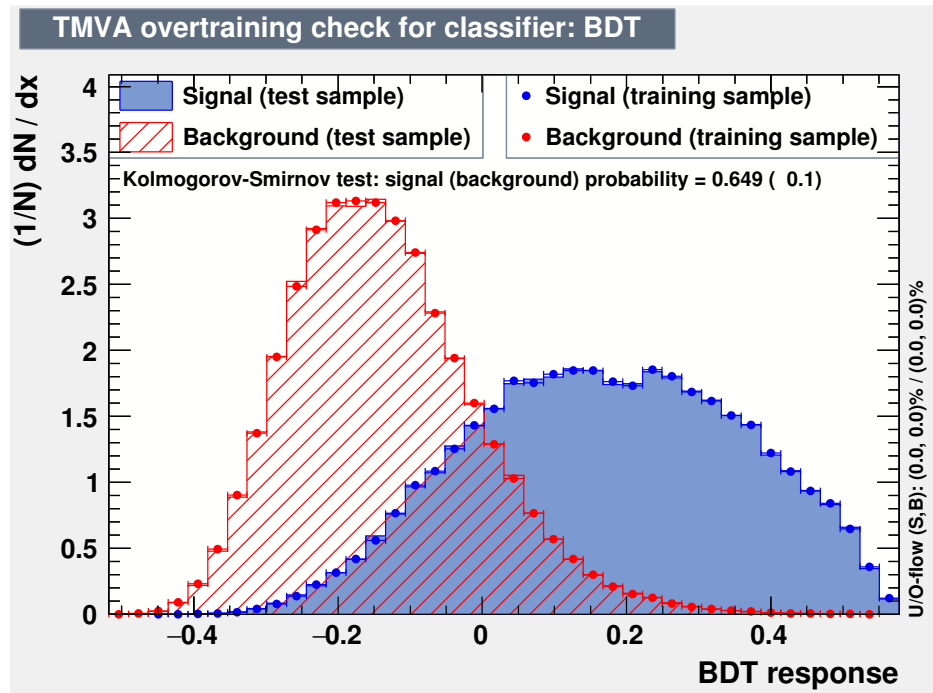

Energy loss correction

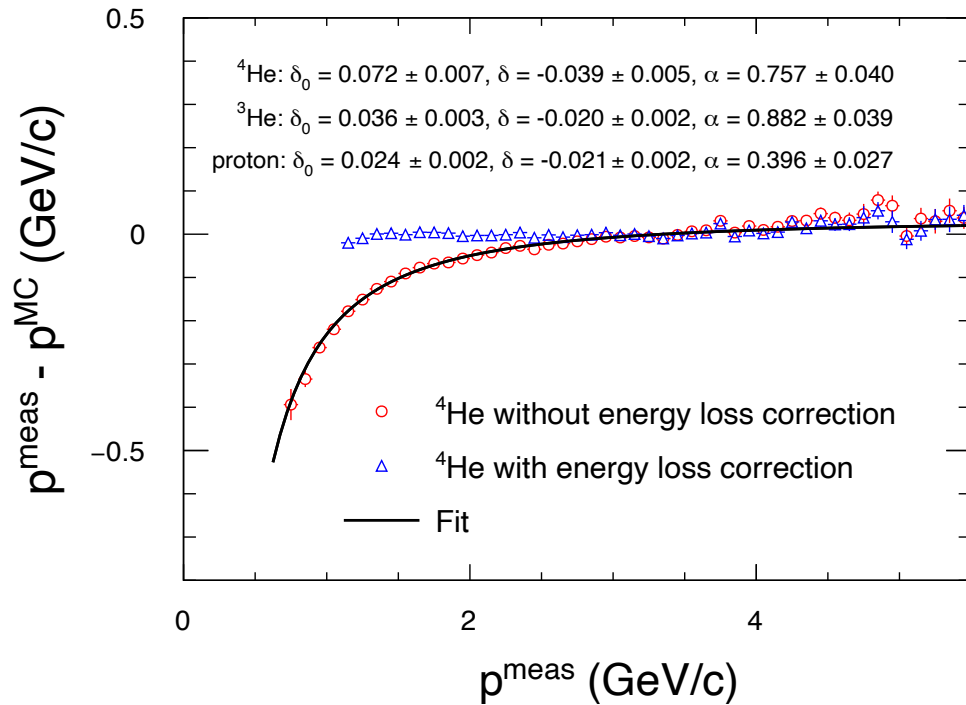

Fit function: $y = \delta_0 + \delta \left(1 + \frac{m^2}{x^2}\right)^\alpha$

Cross check with Λ invariant mass

Correction due to magnetic field distortion

Momentum of decay daughters $\times 0.998$

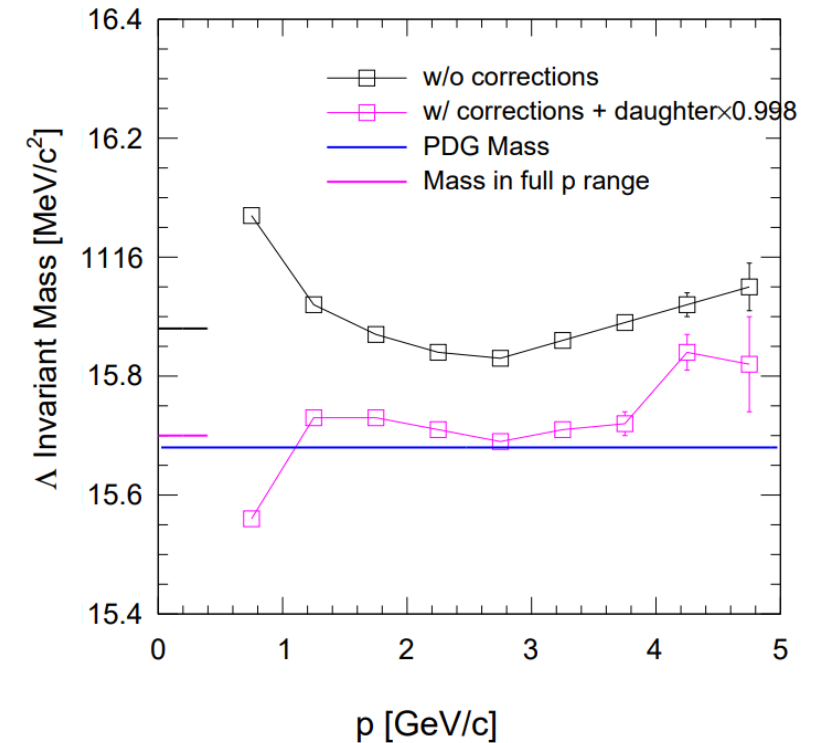

${}^4_{\Lambda}\text{H}$ and ${}^4_{\Lambda}\text{He}$ invariant mass



STAR, arXiv:XXXX The invariant mass distributions of ${}^4_{\Lambda}\text{H}$ and ${}^4_{\Lambda}\text{He}$ with corrections.

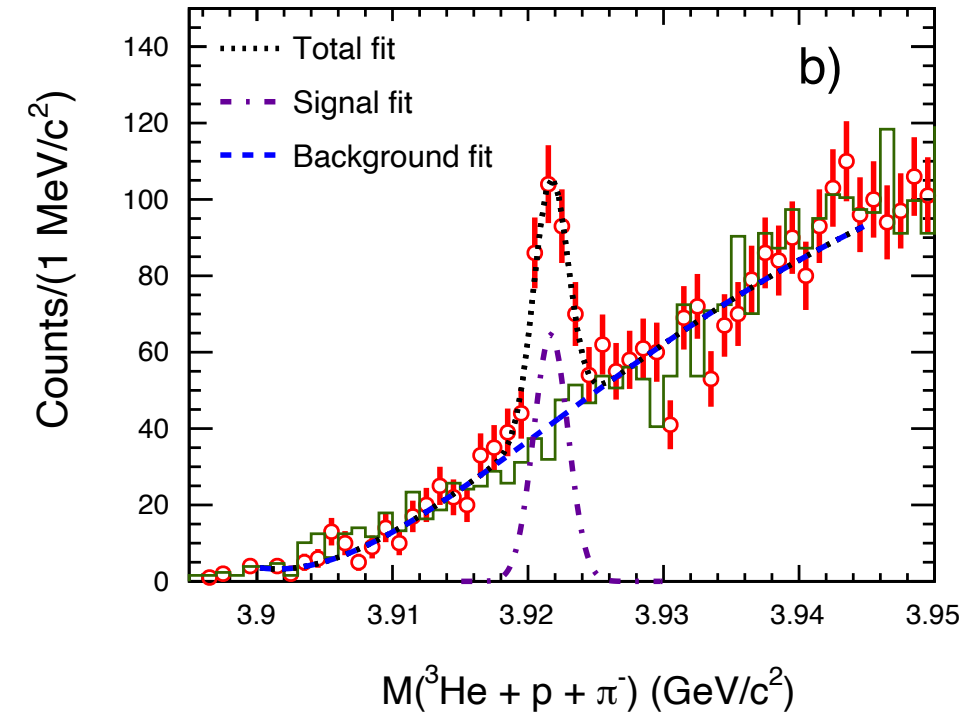
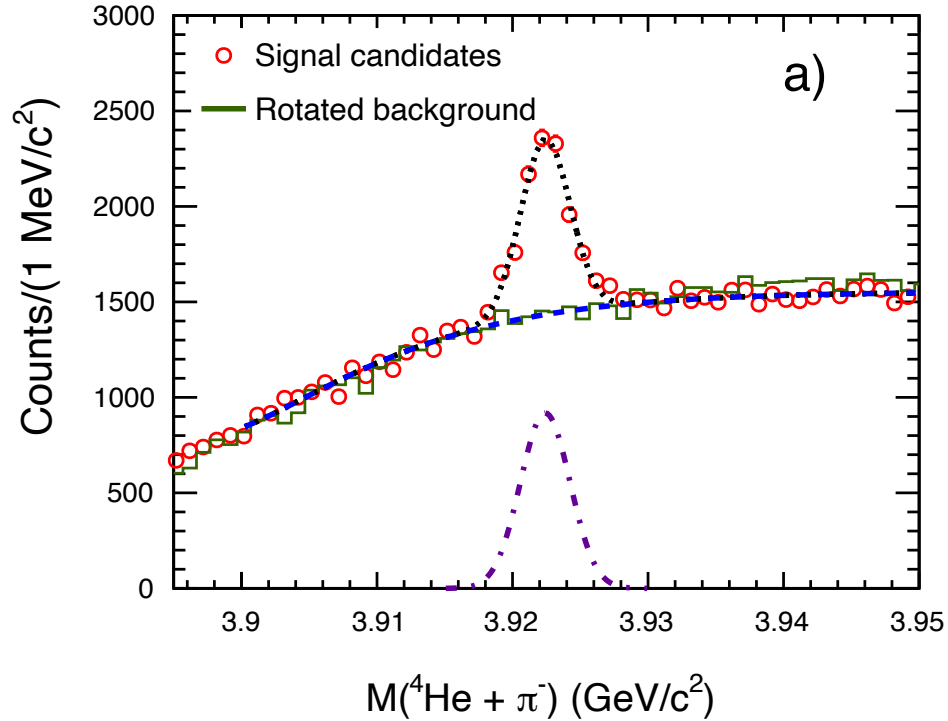

■ Background : rotate ${}^4\text{He}$ or ${}^3\text{He}$ track by 180 degrees

■ Fit function :

$$f(x) = \frac{A}{\sqrt{2\pi}\sigma} \exp\left(-\frac{(x-\mu)^2}{2\sigma^2}\right) + p_0 \exp\left(-\frac{x-p_1}{p_2}\right) + p_3 \exp\left(-\frac{x-p_1}{p_4}\right) + p_5$$

■ $m({}^4_{\Lambda}\text{H}) = 3922.38 \pm 0.06(\text{stat.}) \pm 0.14(\text{syst.}) \text{ MeV}/c^2$

■ $m({}^4_{\Lambda}\text{He}) = 3921.69 \pm 0.13(\text{stat.}) \pm 0.12(\text{syst.}) \text{ MeV}/c^2$

Systematic uncertainties for Λ binding energies.

| Error source | ${}^4_{\Lambda}\text{H}$ Systematic error (MeV) | ${}^4_{\Lambda}\text{He}$ Systematic error (MeV) |
|-------------------------|---|--|
| Momentum scaling factor | 0.11 | 0.11 |
| Energy loss correction | 0.08 | 0.05 |
| BDT cut | 0.03 | 0.01 |
| Total | 0.14 | 0.12 |

- Systematic uncertainties mainly come from momentum corrections.
- As tested in the MC simulation, the systematic uncertainty from the momentum scaling factor can be mostly canceled when we calculate the binding energy difference between ${}^4_{\Lambda}\text{H}$ and ${}^4_{\Lambda}\text{He}$.

Λ binding energy

- Calculate the Λ binding energy according to the masses of hypernuclei and their constituents:

$$B_{\Lambda} = (M_{\Lambda} + M_{core} - M_{hypernucleus})c^2$$

$$M_{core} = M(\text{Triton}) \text{ or } M(\text{He3})$$

| | Λ | Triton | He3 |
|----------------------------|-----------|---------|---------|
| Mass (MeV/c ²) | 1115.68 | 2808.92 | 2808.39 |

- $B_{\Lambda}({}^4_{\Lambda}\text{H}) = 2.22 \pm 0.06(\text{stat.}) \pm 0.14(\text{syst.}) \text{ MeV}$
- $B_{\Lambda}({}^4_{\Lambda}\text{He}) = 2.38 \pm 0.13(\text{stat.}) \pm 0.12(\text{syst.}) \text{ MeV}$

Energy level schemes of ${}^4_{\Lambda}\text{H}$ and ${}^4_{\Lambda}\text{He}$ in terms of Λ binding energies. The ground states binding energies are from this analysis. The values for excited states are obtained from the γ -ray transition energies.

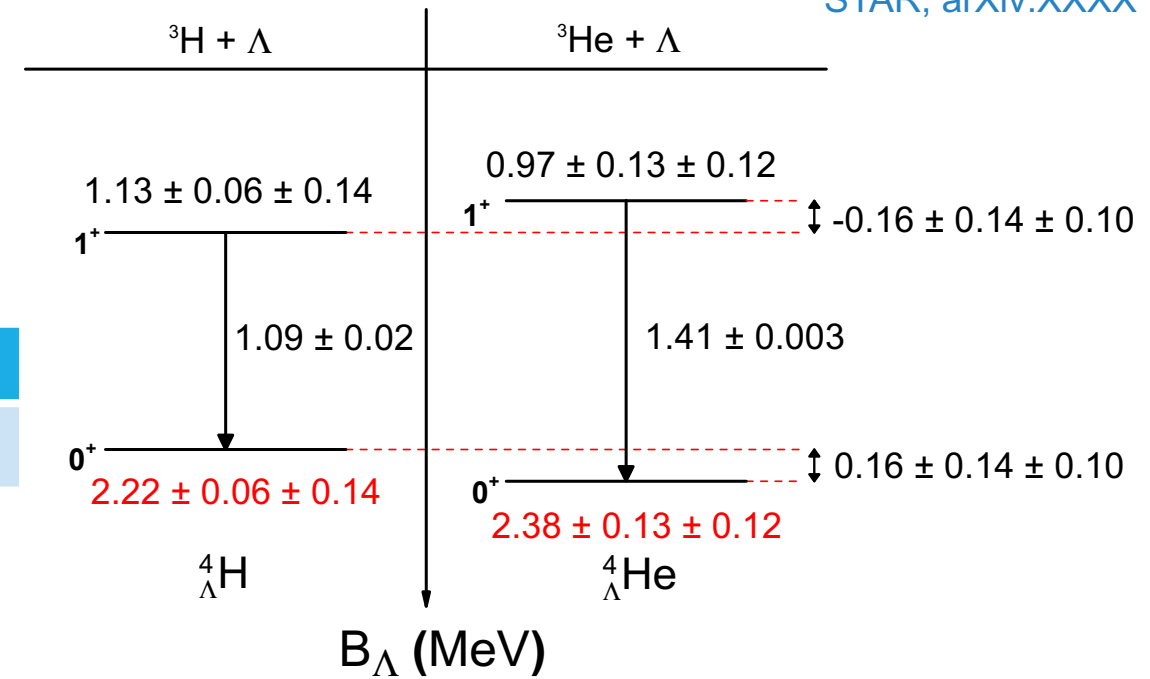

M. Bedjidian et al., PLB 62, 467-470
J-PARC E13 Collaboration, PRL 115, 222501 (2015)

Charge symmetry breaking



STAR, arXiv:XXXX

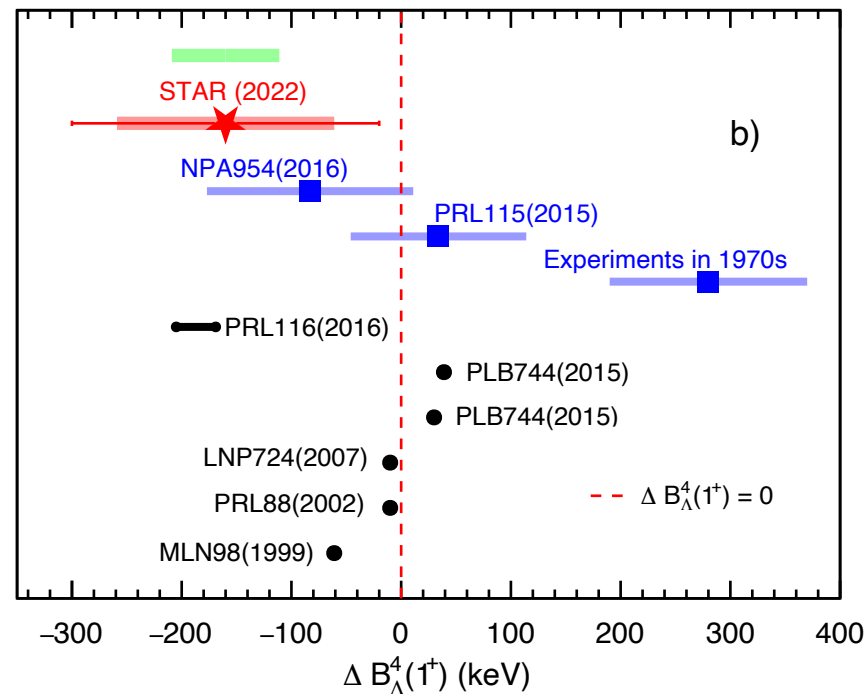
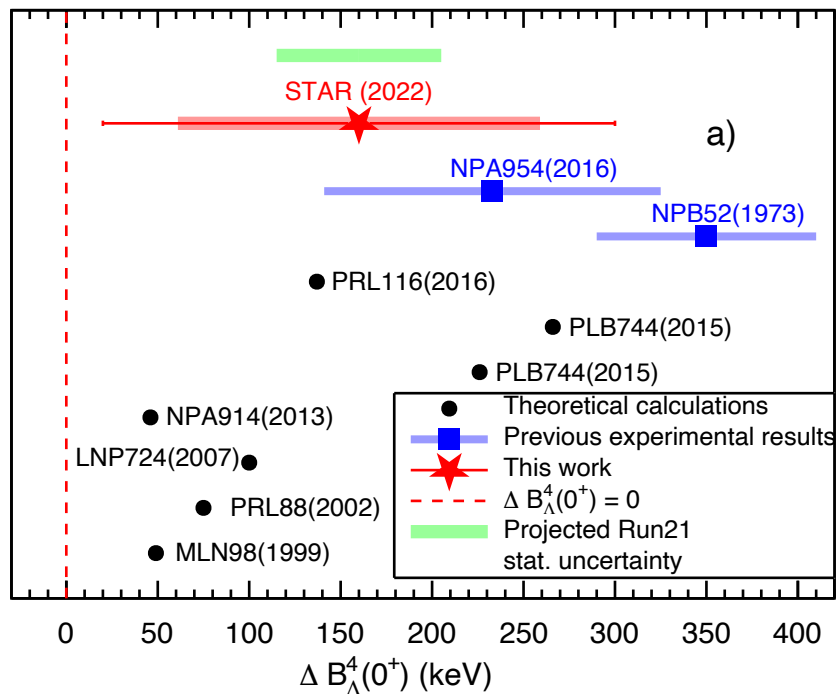

- The Λ binding energy difference between ${}^4_{\Lambda}\text{H}$ and ${}^4_{\Lambda}\text{He}$ in ground states (left figure) and in excited states (right figure). The green shadows are projected statistical uncertainties obtained according to the high statistics run 2021 3 GeV data (~ 2 billion events).
- $\Delta B_{\Lambda}(0^+) = 160 \pm 140(\text{stat.}) \pm 100(\text{syst.}) \text{ keV}$
- $\Delta B_{\Lambda}(1^+) = -160 \pm 140(\text{stat.}) \pm 100(\text{syst.}) \text{ keV}$
- Charge symmetry breaking effects in ground states and excited states **are comparable**.

Summary



- Invariant masses and Λ binding energies of ${}^4_{\Lambda}H$ and ${}^4_{\Lambda}He$ have been measured in 3 GeV Au+Au collisions :
 $m({}^4_{\Lambda}H) = 3922.38 \pm 0.06(\text{stat.}) \pm 0.14(\text{syst.}) \text{ MeV}/c^2$, $B_{\Lambda}({}^4_{\Lambda}H) = 2.22 \pm 0.06(\text{stat.}) \pm 0.14(\text{syst.}) \text{ MeV}$
 $m({}^4_{\Lambda}He) = 3921.69 \pm 0.13(\text{stat.}) \pm 0.12(\text{syst.}) \text{ MeV}/c^2$, $B_{\Lambda}({}^4_{\Lambda}He) = 2.38 \pm 0.13(\text{stat.}) \pm 0.12(\text{syst.}) \text{ MeV}$
- To study the charge symmetry breaking in $A = 4$ hypernuclei, the Λ binding energy differences between ${}^4_{\Lambda}H$ and ${}^4_{\Lambda}He$ in ground states and excited states have been measured/extracted :
 $\Delta B_{\Lambda}(0^+) = 0.16 \pm 0.14(\text{stat.}) \pm 0.10(\text{syst.}) \text{ MeV}$
 $\Delta B_{\Lambda}(1^+) = -0.16 \pm 0.14(\text{stat.}) \pm 0.10(\text{syst.}) \text{ keV}$
- Our results show that the charge symmetry breaking effect in excited states is negative, and the magnitude is comparable to the ground states.

Acknowledgement:

This project has received funding from the European Union's Horizon 2020 research and innovation programme under grant agreement No 824093.

