

# Introduction to the CLIC study

24 March 2010  
Tsinghua University  
W. Wuensch

# Outline

- A bit of history, context and physics objectives
- The main features of CLIC
- Feasibility issues (excluding high gradient/power structures)
- Some features of the project

A bit of history, context and physics objectives

# The early days of multi-TeV linear colliders

CLIC Note 38  
(May, 1987)

EUROPEAN ORGANIZATION FOR NUCLEAR RESEARCH

CERN-LEP-RF/86-06

and

CLIC NOTE 13  
13.2.86

## A TWO-STAGE RF LINEAR COLLIDER USING A SUPERCONDUCTING DRIVE LINAC

W. Schnell

### Abstract

The efficiency from RF input to beam power of a normal conducting travelling-wave linac can be raised above 5% albeit at the price of a very short pulse and an appreciable but probably correctible energy spread. Compensated multibunch operation may yield 30% efficiency but higher order wakefield problems have to be solved and a suitable final focus system must be found. The worst remaining problem seems to be the economic and efficient generation of peak RF power. The solution proposed here consists of a limited number of CW UHF klystrons, a superconducting UHF drive linac and a lightly bunched drive beam of several GeV average energy, transferring energy from the superconducting linac to the main linac via short sections of transfer structures. The power balance of this scheme is analysed and it is found that overall efficiency can be very high. Very dense drive bunches are required. Present-day performance of superconducting cavities is already sufficient to make the scheme viable at main linac accelerating gradients approaching 100 MV/m.

Geneva, Switzerland  
February 1986

APR 7 1986  
NLS LIBRARY

ORGANISATION EUROPÉENNE POUR LA RECHERCHE NUCLÉAIRE  
**CERN** EUROPEAN ORGANIZATION FOR NUCLEAR RESEARCH

REPORT FROM THE ADVISORY PANEL ON THE PROSPECTS  
FOR  $e^+e^-$  LINEAR COLLIDERS IN THE TeV RANGE

GENEVA  
1987

# The years of many linear collider studies

MPL PHE 93-14  
ECFA 93-154  
Vol. 1  
June 1993

## LC92

ECFA WORKSHOP ON  $e^+e^-$  LINEAR COLLIDERS



25 July - 1 August 1992

PROCEEDINGS  
VOL. I

EDITOR: Ron Squires

## TABLE OF CONTENTS

### Volume I. Introductory Session

Forward	v
List of Attendees	vii
<b>Opening Address</b>	
Guy Coignet	1
<b>Physics with Linear Colliders</b>	
Peter Zerwas	11
<b>SLC</b>	
John Seeman	93
<b>DLC</b>	
Thomas Weiland	121
<b>NLC</b>	
Ronald Ruth	155
<b>JLC</b>	
Koji Takata	207
<b>TESLA</b>	
Maury Tigner	227
<b>VLEPP</b>	
Vladimir Balakin	243
<b>CLIC</b>	
Wolfgang Schnell	267
<b>FFTB</b>	
David Burke	283
<b>Appendices</b>	
Appendix A. Addresses of Attendees	a1
Appendix B. Bit of the Action	a15

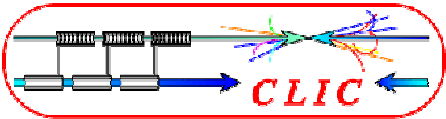

## *World consensus about a Linear Collider as the next HEP facility after LHC*

- **2001:** ICFA recommendation of a world-wide collaboration to construct a high luminosity e<sup>+</sup>/e<sup>-</sup> Linear Collider with an energy range up to at least 400 GeV/c
- **2004:** International Technology Recommendation Panel selecting the Super-Conducting technology for an International Linear Collider (ILC) Linear Collider in the TeV energy range
- **2004:** CERN council support for R&D addressing the feasibility of the CLIC technology to possibly extend Linear Colliders into the Multi-TeV energy range.

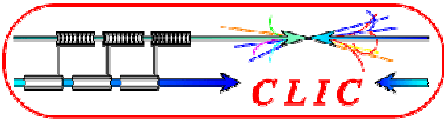

# CERN Council Strategy Group (Lisbon July 2006)

## The European strategy for particle physics

Particle physics stands on the threshold of a new and exciting era of discovery. The next generation of experiments will explore new domains and probe the deep structure of space-time. They will measure the properties of the elementary constituents of matter and their interactions with unprecedented accuracy, and they will uncover new phenomena such as the Higgs boson or new forms of matter. Long-standing puzzles such as the origin of mass, the matter-antimatter asymmetry of the Universe and the mysterious dark matter and energy that permeate the cosmos will soon benefit from the insights that new measurements will bring. Together, the results will have a profound impact on the way we see our Universe; *European particle physics should thoroughly exploit its current exciting and diverse research programme. It should position itself to stand ready to address the challenges that will emerge from exploration of the new frontier, and it should participate fully in an increasingly global adventure.*

### General issues

1. European particle physics is founded on strong national institutes, universities and laboratories and the CERN Organization; Europe should maintain and strengthen its central position in particle physics.
2. Increased globalization, concentration and scale of particle physics make a well coordinated strategy in Europe paramount; this strategy will be defined and updated by CERN Council as outlined below.

### Scientific activities

3. The LHC will be the energy frontier machine for the foreseeable future, maintaining European leadership in the field; the highest priority is to fully exploit the physics potential of the LHC, resources for completion of the initial programme have to be secured such that machine and experiments can operate optimally at their design performance. A subsequent major luminosity upgrade (SLHC), motivated by physics results and operation experience, will be enabled by focussed R&D; to this end, R&D for machine and detectors has to be vigorously pursued now and centrally organized towards a luminosity upgrade by around 2015.

4. In order to be in the position to push the energy and luminosity frontier even further it is vital to strengthen the advanced accelerator R&D programme; a coordinated programme should be intensified, to develop the CLIC technology and high performance magnets for future accelerators, and to play a significant role in the study and development of a high-intensity neutrino facility.
5. It is fundamental to complement the results of the LHC with measurements at a linear collider. In the energy range of 0.5 to 1 TeV, the ILC, based on superconducting technology, will provide a unique scientific opportunity at the precision frontier; there should be a strong well-coordinated European activity, including CERN, through the Global Design Effort, for its design and technical preparation towards the construction decision, to be ready for a new assessment by Council around 2010.
6. Studies of the scientific case for future neutrino facilities and the R&D into associated technologies are required to be in a position to define the optimal neutrino programme based on the information available in around 2012; Council will play an active role in promoting a coordinated European participation in a global neutrino programme.
7. A range of very important non-accelerator experiments take place at the overlap between particle and astroparticle physics exploring otherwise inaccessible phenomena; Council will seek to work with ApPEC to develop a coordinated strategy in these areas of mutual interest.

In order to be in the position to push the energy and luminosity frontier even further it is vital to strengthen the advanced accelerator R&D programme; a coordinated programme should be intensified, to develop the CLIC technology and high performance magnets for future accelerators, and to play a significant role in the study and development of a high-intensity neutrino facility.

It is fundamental to complement the results of the LHC with measurements at a linear collider. In the energy range of 0.5 to 1 TeV, the ILC, based on superconducting technology, will provide a unique scientific opportunity at the precision frontier; there should be a strong well-coordinated European activity, including CERN, through the Global Design Effort, for its design and technical preparation towards the construction decision, to be ready for a new assessment by Council around 2010.

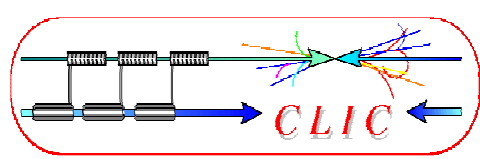

- New physics expected in TeV energy range
  - E.g. motivated by particle astrophysics (dark matter)
  - Higgs, Supersymmetry, extra dimensions, ...?
- LHC will indicate what physics, and at which energy scale (is 500 GeV enough or need for multi TeV? )
- Even if multi-TeV is final goal, most likely **CLIC would run over a range of energies** (e.g. 0.5 – 3.0 TeV)



# How? Context

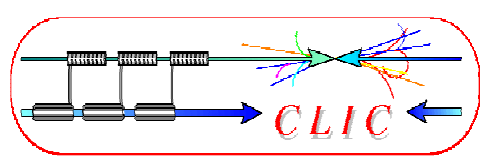

In several aspects the CLIC detector will be more challenging than ILC case, due to:

- Energy 500 GeV => 3 TeV
- More severe background conditions
  - Due to higher energy
  - Due to smaller beam sizes
- Time structure of the accelerator

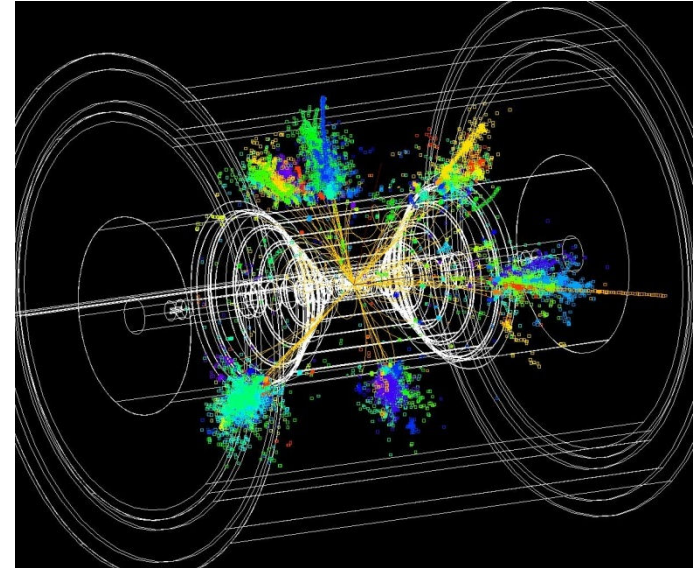

Nevertheless, most of the R&D currently carried out for the ILC is most relevant for CLIC.

Many years of investment in ILC  $e^+e^-$  physics/detector simulations, hardware R&D and detector concepts

No need to duplicate work.

# The main features of CLIC

- High charge **Drive Beam** (low energy)
- Low charge **Main Beam** (high collision energy)
- => Simple tunnel, no active elements
- => Modular, easy energy upgrade in stages

**CLIC TUNNEL CROSS-SECTION**

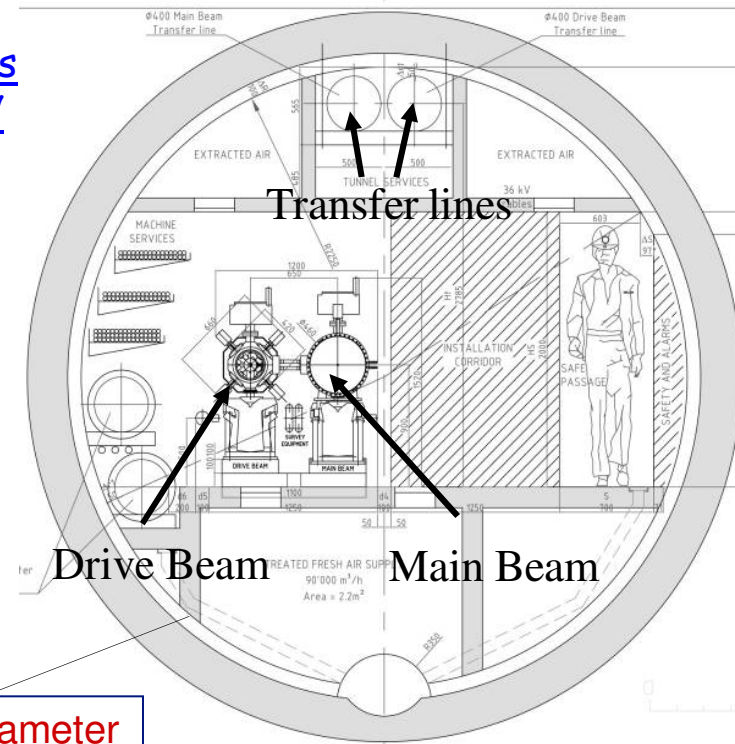
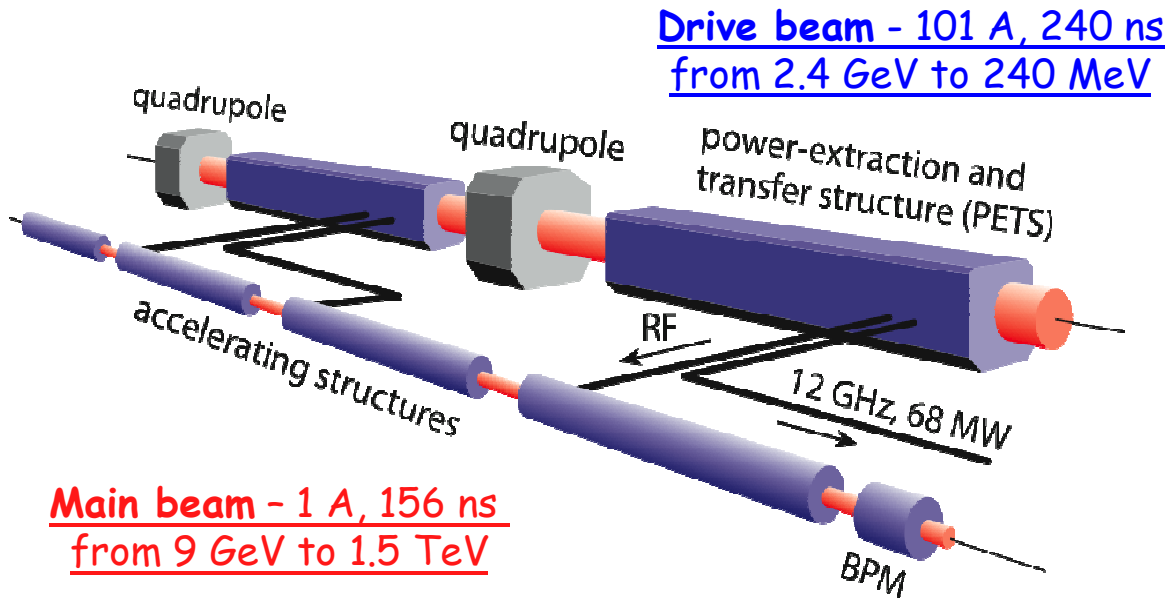

- **Very high gradients** ( $>100 \text{ MV/m}$ ) possible with NC accelerating structures at high RF frequencies
- Extract required high RF power from an **intense** e- “**drive beam**”
- Generate **efficiently** long pulse and compress it

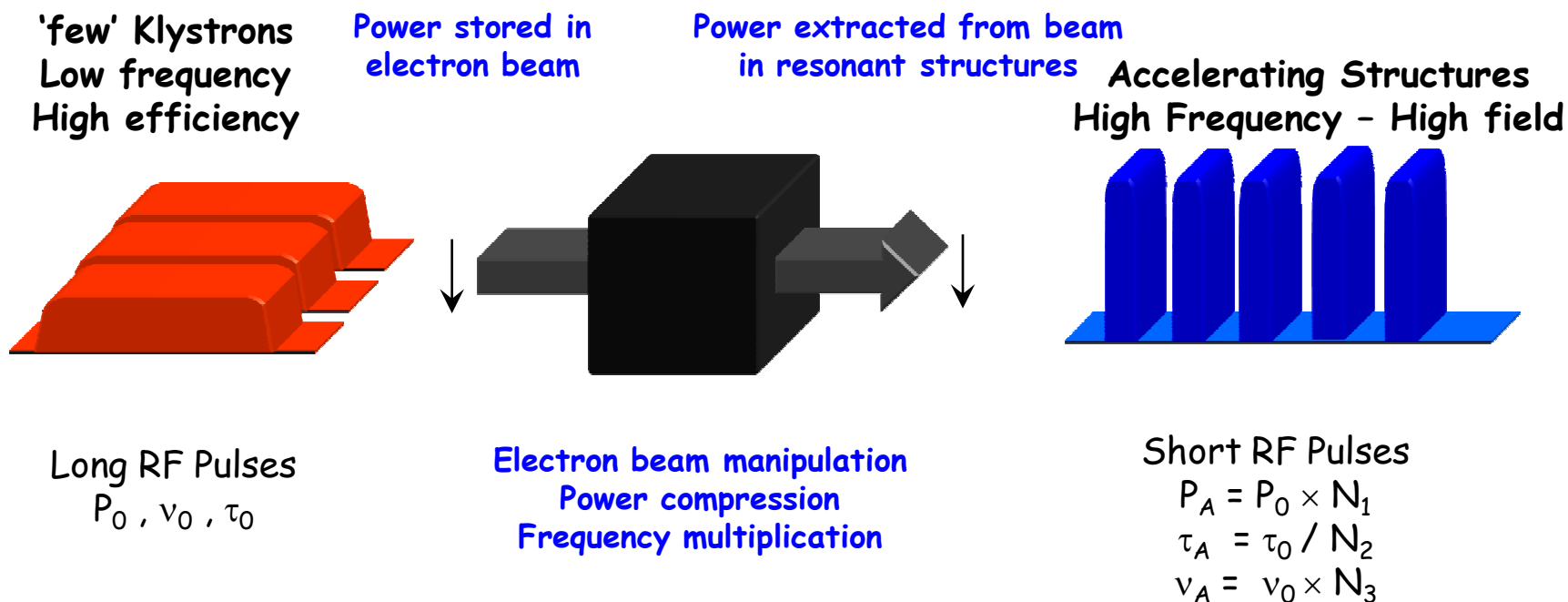

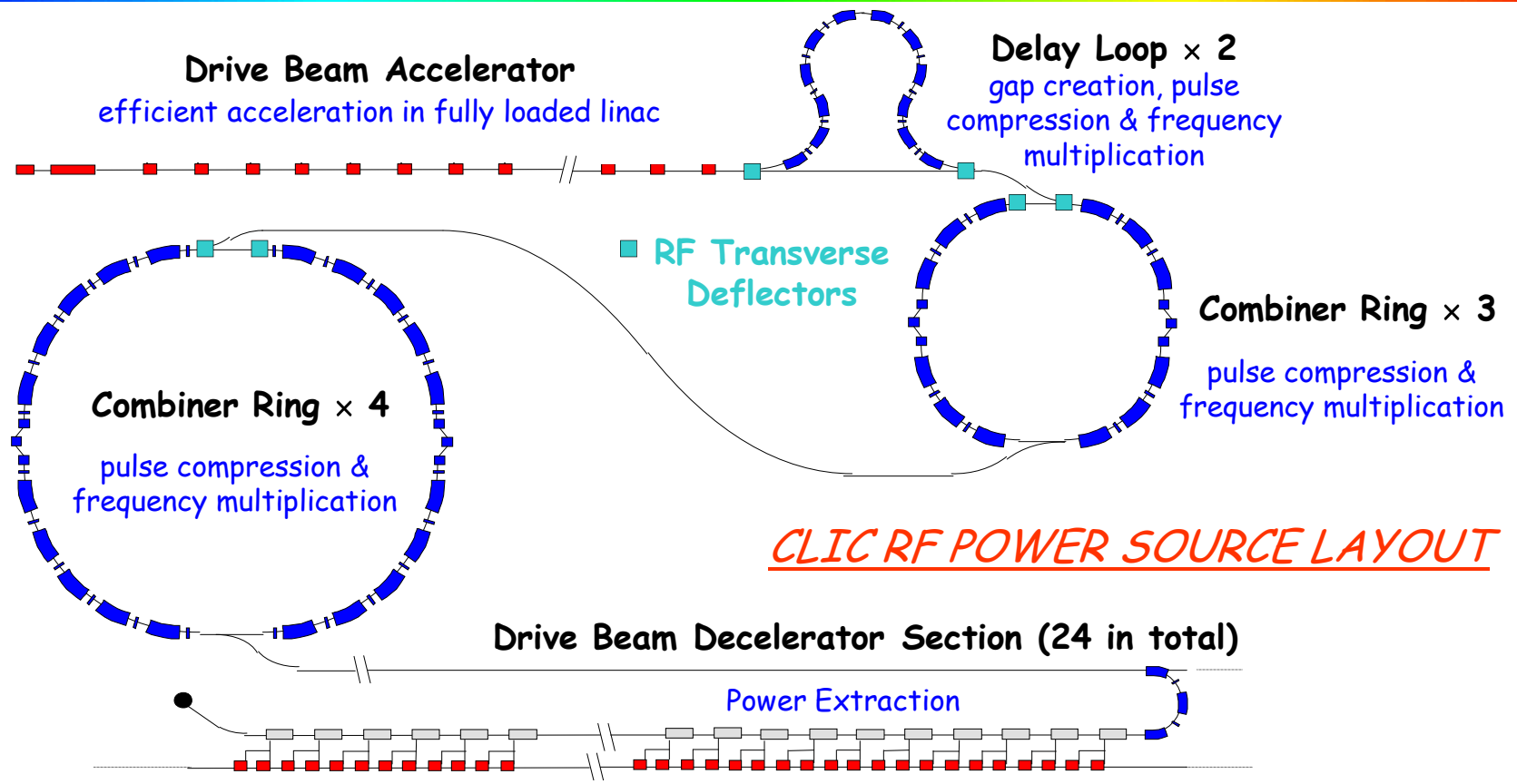

### Drive beam time structure - initial

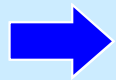
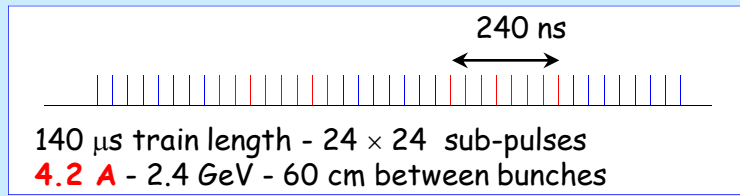

### Drive beam time structure - final

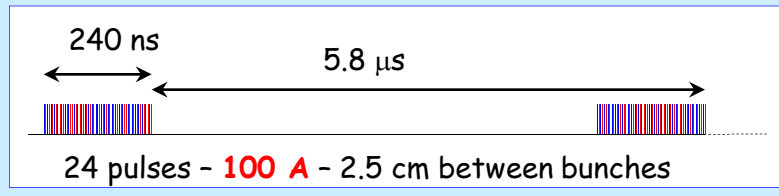

- **efficient** power transfer from RF to the beam needed

“Standard” situation:

- **small** beam loading
- power at structure exit lost in load

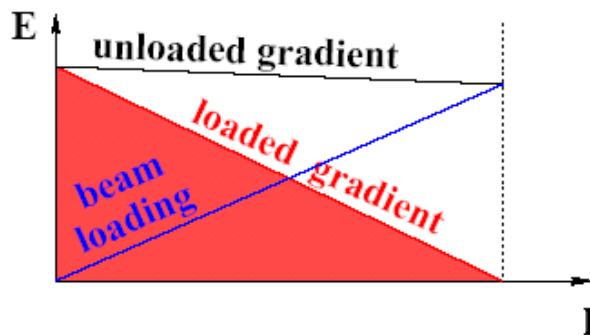
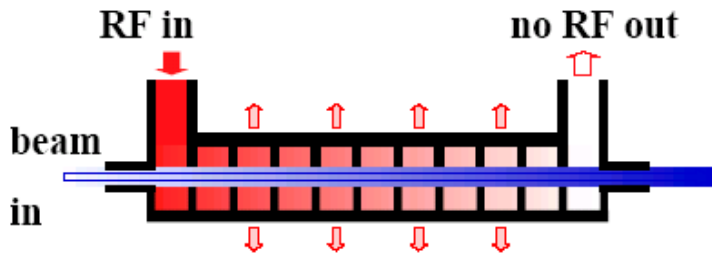
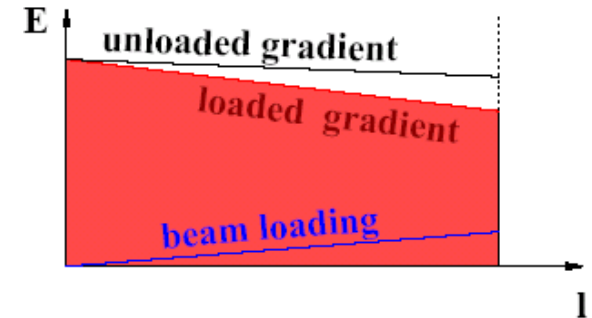

“Efficient” situation:

- high beam current
- **high** beam loading
- no power flows into load
- $V_{ACC} \approx 1/2 V_{unloaded}$

- basic principle of **drive beam** generation
- transform very long pulses into short pulses with higher power and higher frequency
- use **RF deflectors** to **interleave** bunches
  - $\Rightarrow$  double power
  - $\Rightarrow$  double frequency

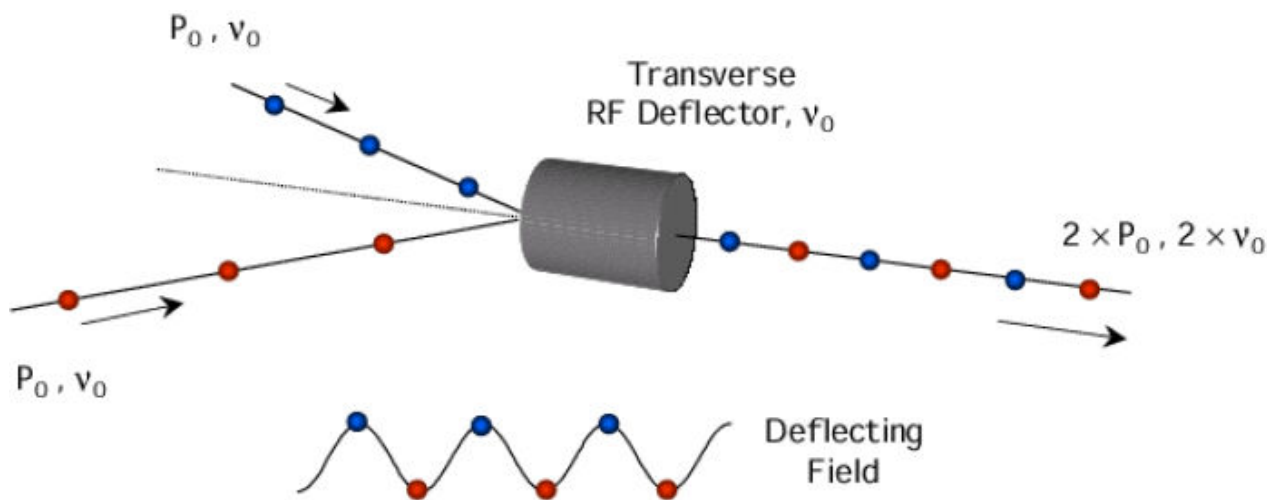

combination **factors** up to 5 reachable in a ring

$$C_{ring} = (n + 1/4) \lambda$$

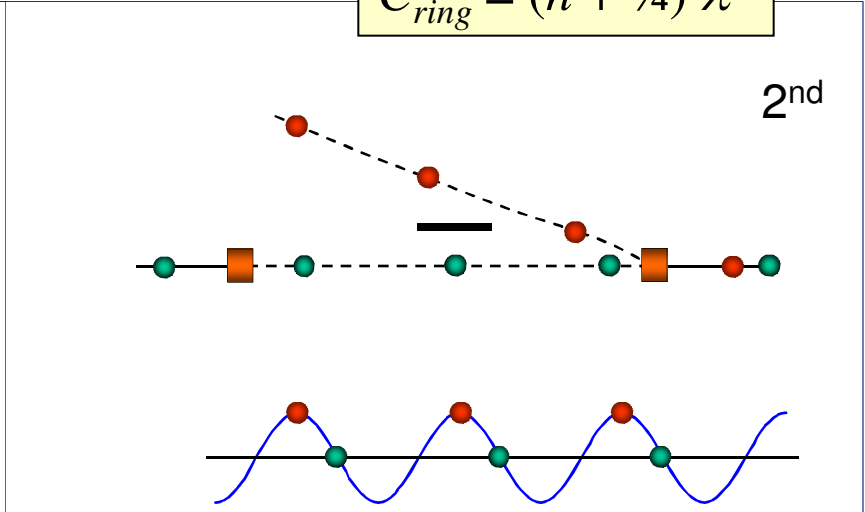
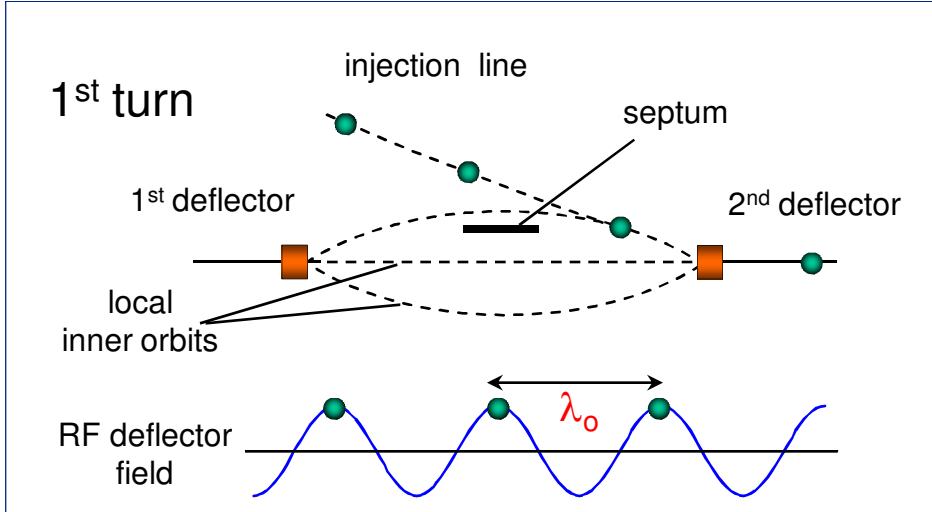

$C_{ring}$  has to correspond to the distance of pulses from the previous combination stage!

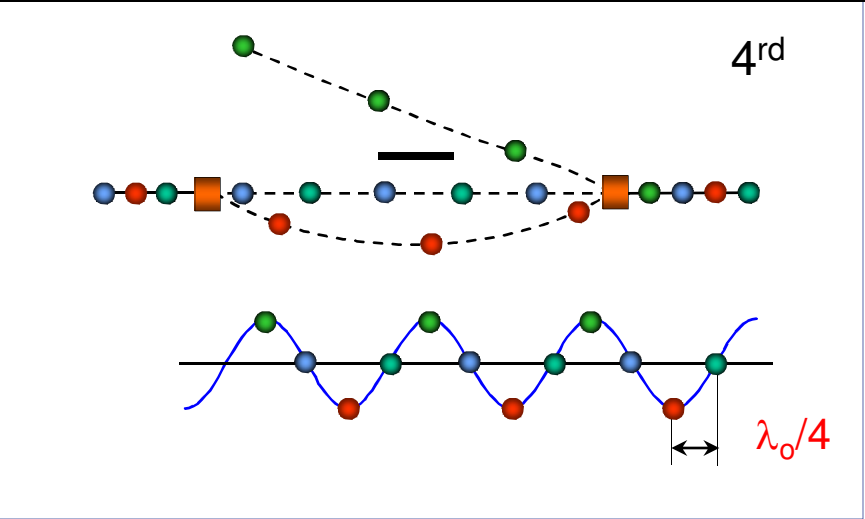
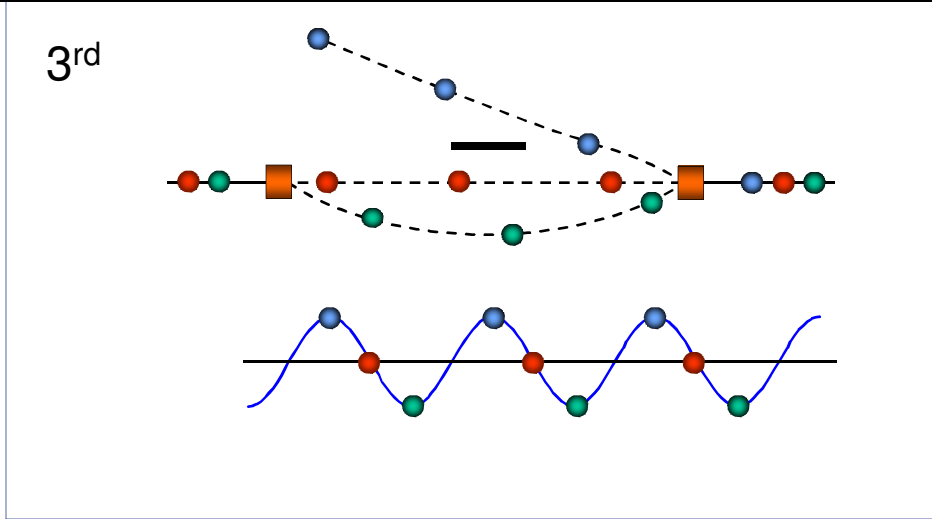



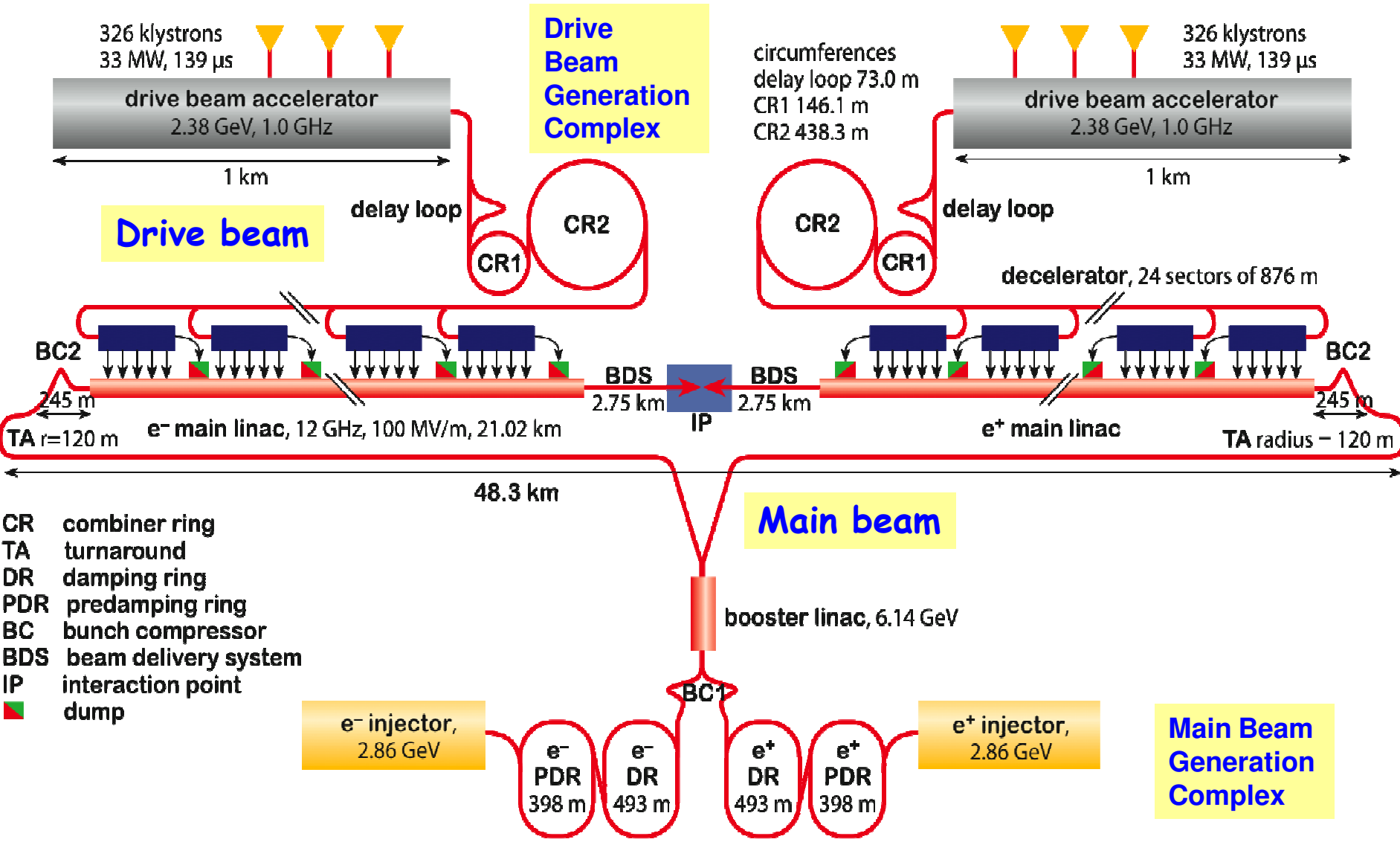

- CR combiner ring
- TA turnaround
- DR damping ring
- PDR predamping ring
- BC bunch compressor
- BDS beam delivery system
- IP interaction point
- █ dump

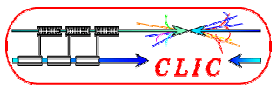

# CLIC Main Parameters

<http://cdsweb.cern.ch/record/1132079?ln=fr> <http://clic-meeting.web.cern.ch/clic-meeting/clictable2007.html>

Center-of-mass energy	CLIC 500 G		CLIC 3 TeV	
	Conservative	Nominal	Conservative	Nominal
Accelerating structure	502		G	
Total (Peak 1%) luminosity	$0.9(0.6) \cdot 10^{34}$	$2.3(1.4) \cdot 10^{34}$	$1.5(0.73) \cdot 10^{34}$	$5.9(2.0) \cdot 10^{34}$
Repetition rate (Hz)	50			
Loaded accel. gradient MV/m	80		100	
Main linac RF frequency GHz	12			
Bunch charge $10^9$	6.8		3.72	
Bunch separation (ns)	0.5			
Beam pulse duration (ns)	177		156	
Beam power/beam (MWatts)	4.9		14	
Hor./vert. norm. emitt ( $10^{-6}/10^{-9}$ )	3/40	2.4/25	2.4/20	0.66/20
Hor/Vert FF focusing (mm)	10/0.4	8 / 0.1	8 / 0.3	4 / 0.07
Hor./vert. IP beam size (nm)	248 / 5.7	202 / 2.3	83 / 2.0	40 / 1.0
Hadronic events/crossing at IP	0.07	0.19	0.57	2.7
Coherent pairs at IP	10	100	$5 \cdot 10^7$	$3.8 \cdot 10^8$
BDS length (km)	1.87		2.75	
Total site length km	13.0		48.3	
Wall plug to beam transfer eff	7.5%		6.8%	
Total power consumption MW	129.4		415	

# Feasibility issues

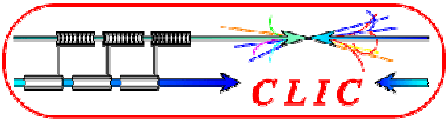

# 10 CLIC Feasibility Issues

- **Two Beam Acceleration:**
  - Drive beam generation
  - Beam Driven RF power generation
  - Two Beam Module
- **RF Structures:**
  - Accelerating Structures (CAS)
  - Power Production Structures (PETS)
- **Ultra low beam emittance and beam sizes**
  - Emittance preservation during generation, acceleration and focusing
  - Alignment and stabilisation
- **Detector**
  - Adaptation to short interval between bunches
  - Adaptation to large background at high beam collision energy
- **Operation and Machine Protection System (MPS)**

- demonstrate remaining **CLIC feasibility** issues, in particular:
  - **Drive Beam generation** (fully loaded acceleration, bunch frequency multiplication)
  - **CLIC accelerating structures**
  - **CLIC power production structures (PETS)**

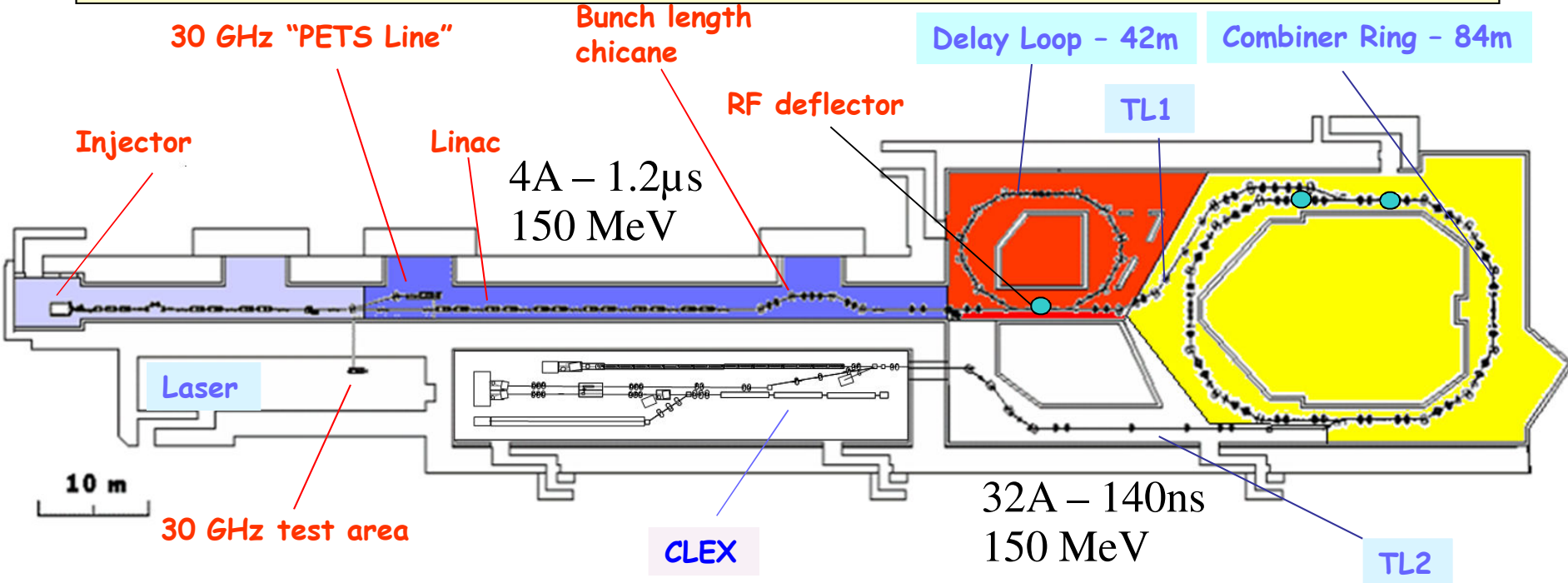

# CTF3 completed, operating 10 months/year, under commissioning: Drive Beam Generation demonstrated

Fully loaded acceleration  
RF to beam transfer:  
95.3 % measured

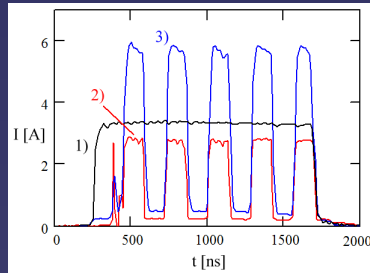

7 A @ 3 GHz

DELAY  
LOOP

4 A – 1.2  $\mu$ s  
120 Mev @ 1.5 GHz

COMBINER  
RING

27 A @ 12 GHz

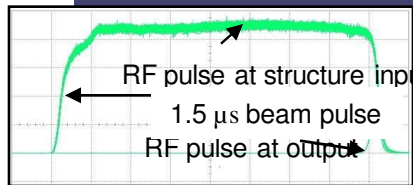
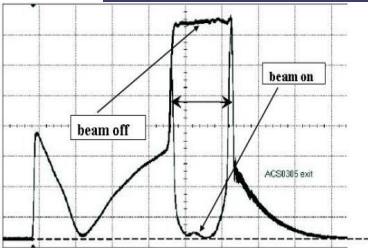

DRIVE BEAM  
LINAC

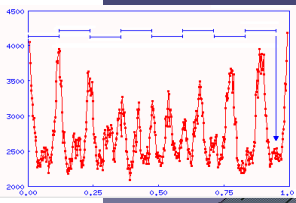

CLEX  
CLIC Experimental  
Area

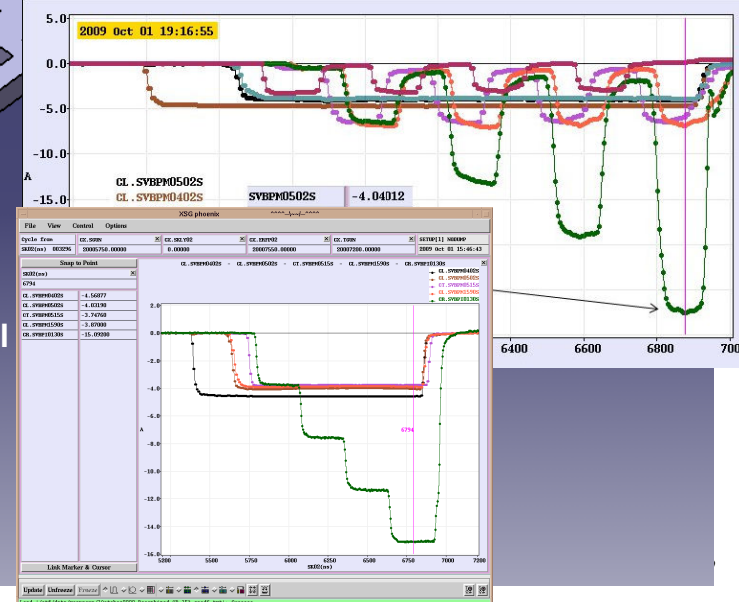



## Delay loop & combiner ring: THE recombination

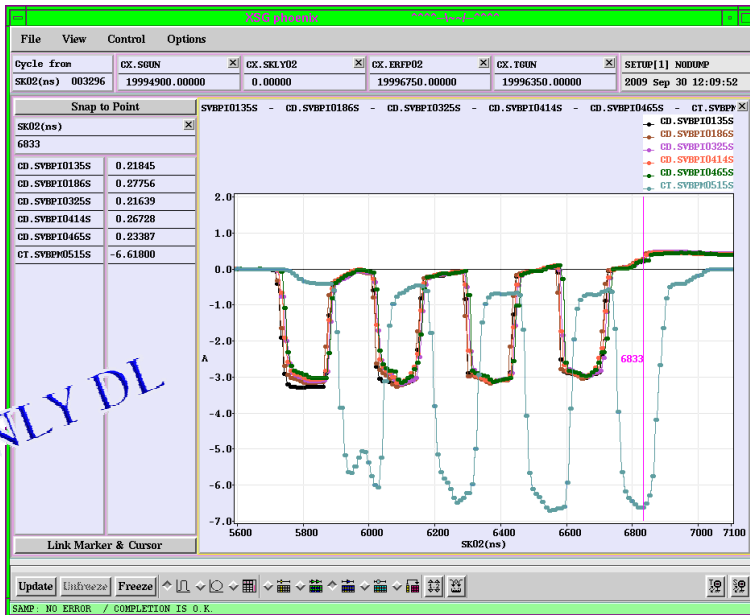
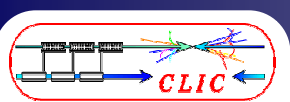

ONLY DL

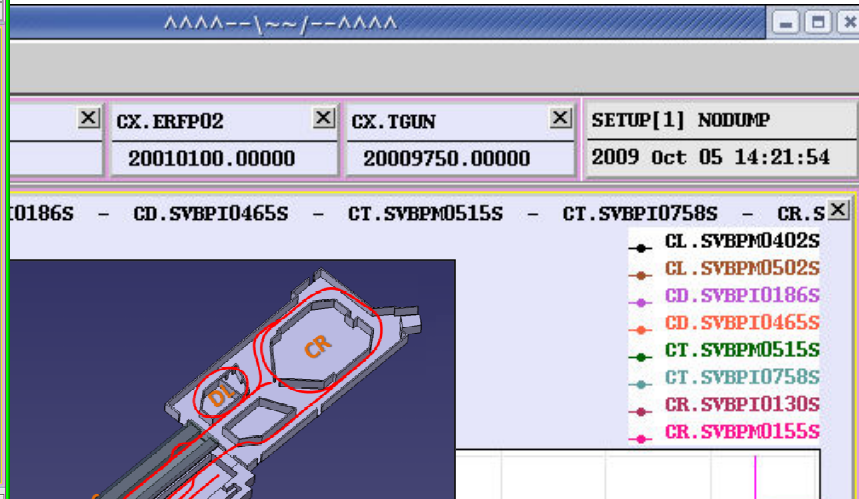

DL & CR

CR.SVBPI0130S	-29.15880
CR.SVBPM0155S	-25.51500

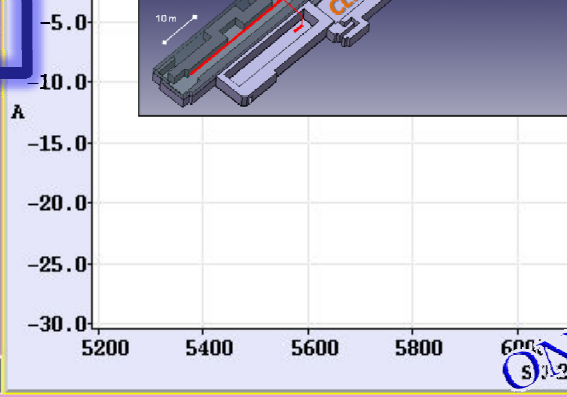

ONLY CR

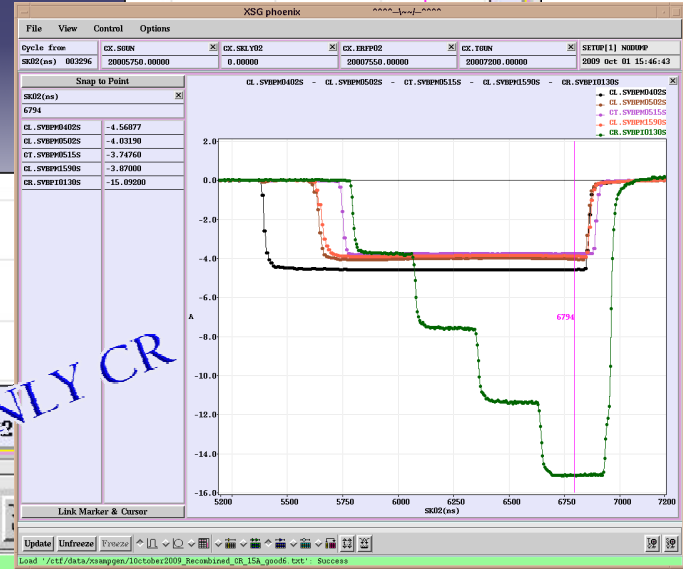

Update Unfreeze Freeze  
 Load '/ctf/data/xsamppgen/50october2009\_Recombined\_DL\_CR\_29A\_e': Success

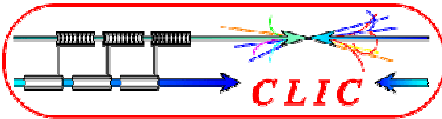

# CTF3/CLEX (CLIC Experimental Area)

**Test beam line (TBL) to study RF power production (1.5 TW at 12 GHz) and drive beam decelerator dynamics, stability & losses**  
**- Two Beam Test Stand to study probe beam acceleration with high fields at high frequency and the feasibility of Two Beam modules**

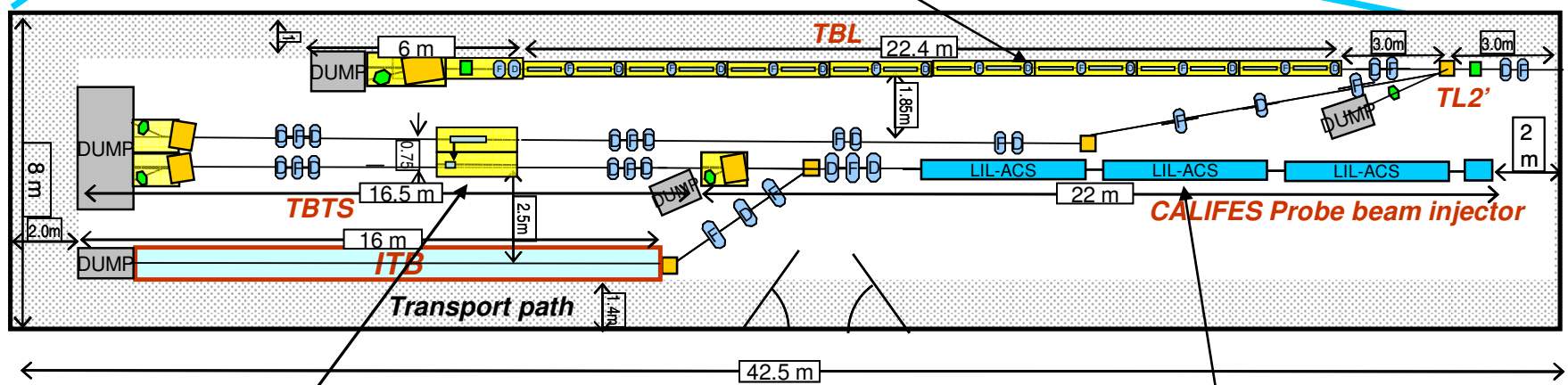
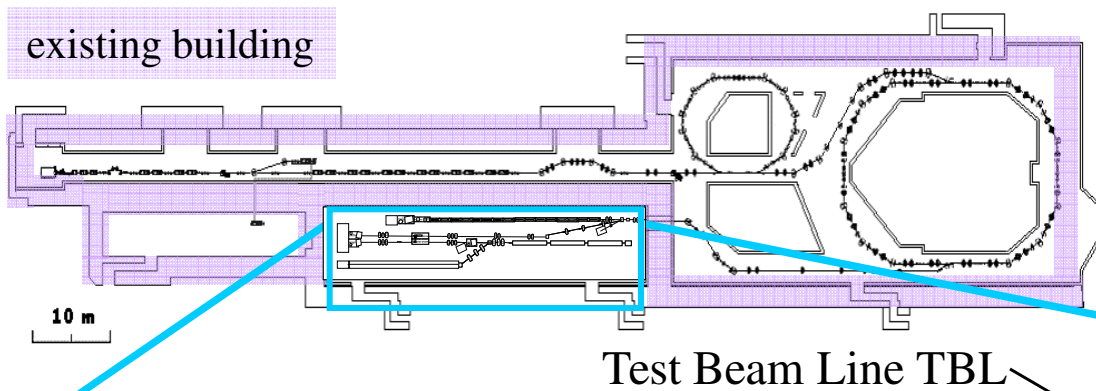

Two Beam Test Stand

Probe Beam

Construction during 2006/beg 2007  
 installation of equipment from  
 2007 - 2009

Beam in CLEX from June 2008 onwards



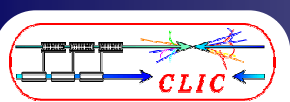

## TBTS, PETS conditioning



- Max beam current through PETS ~ 12 A
- Aggressive, fast conditioning - well beyond CLIC nominal power
- Pulse shortening in splitter and phase shifter

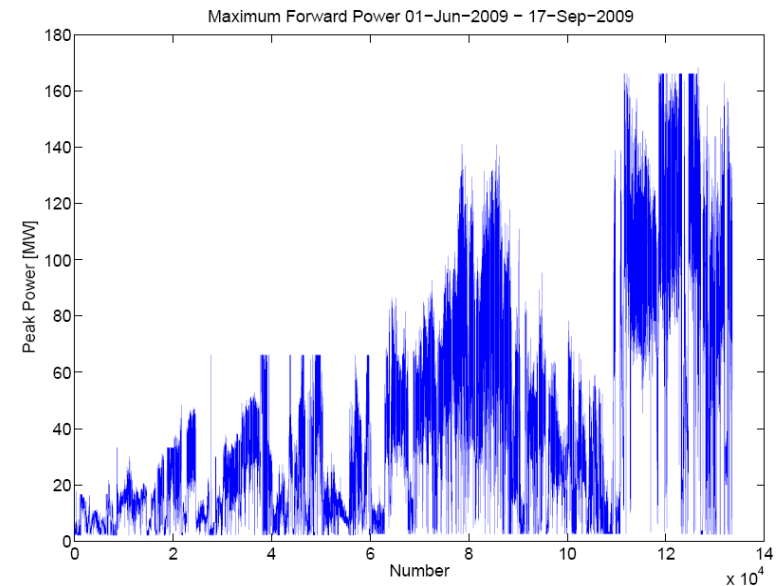
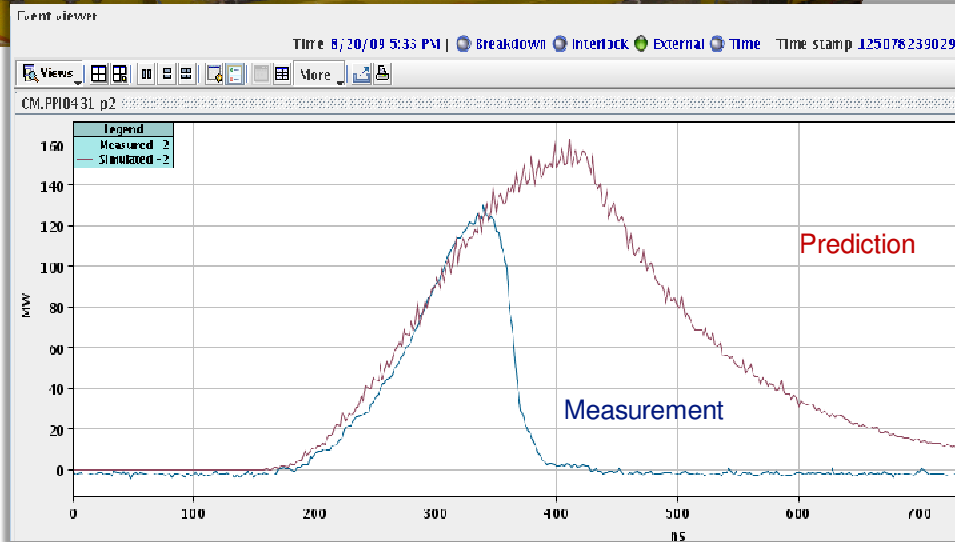
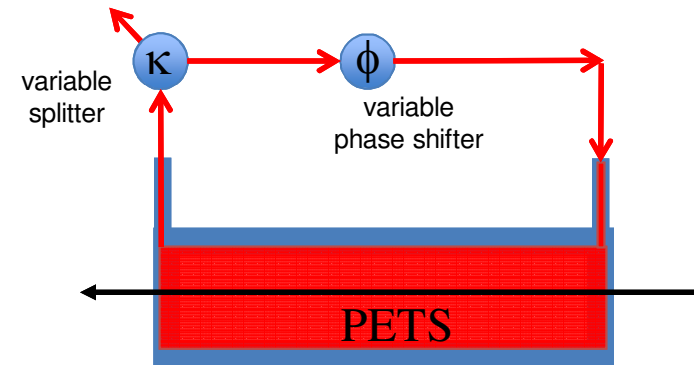

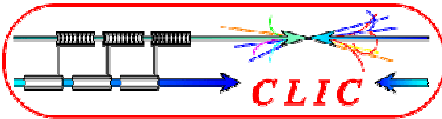

# Two Beam Module tests in CTF3/CLEX

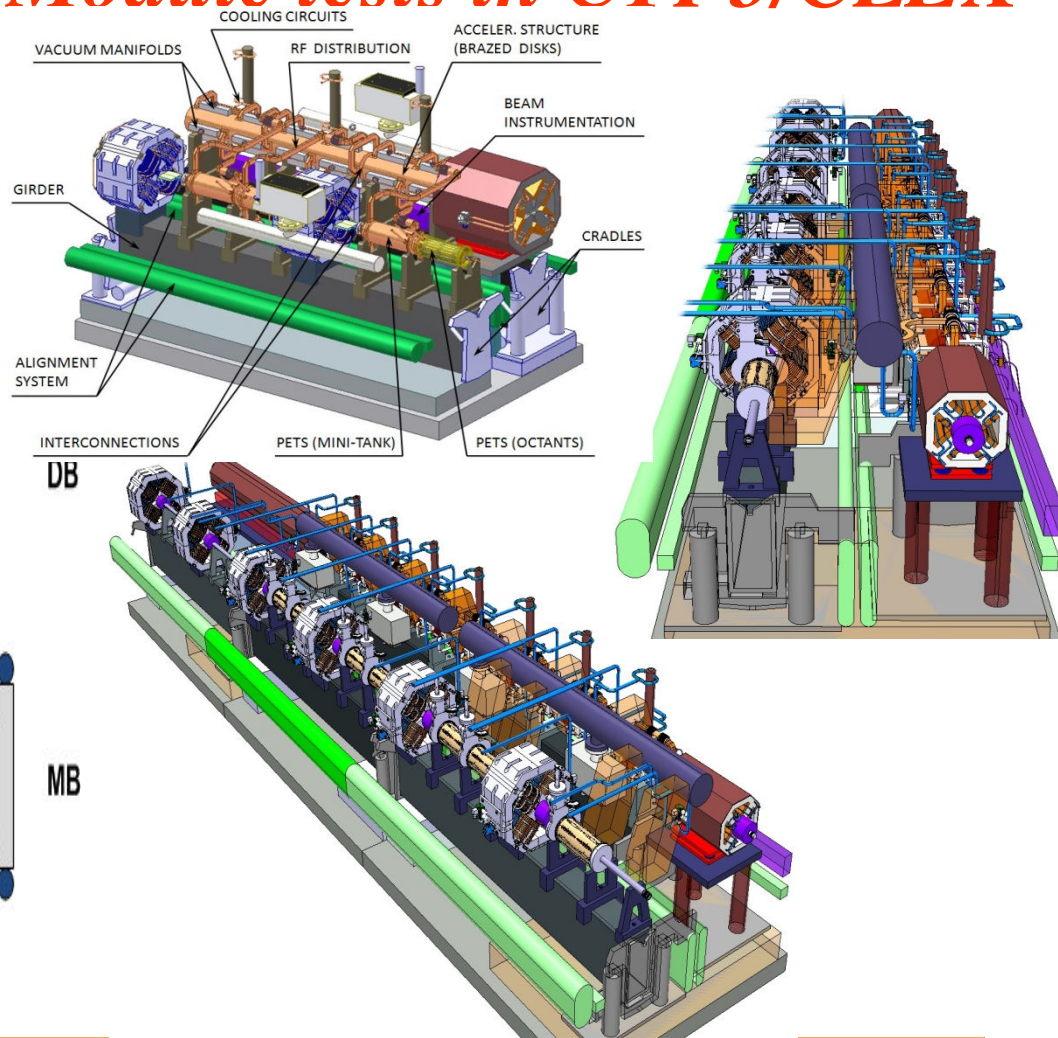
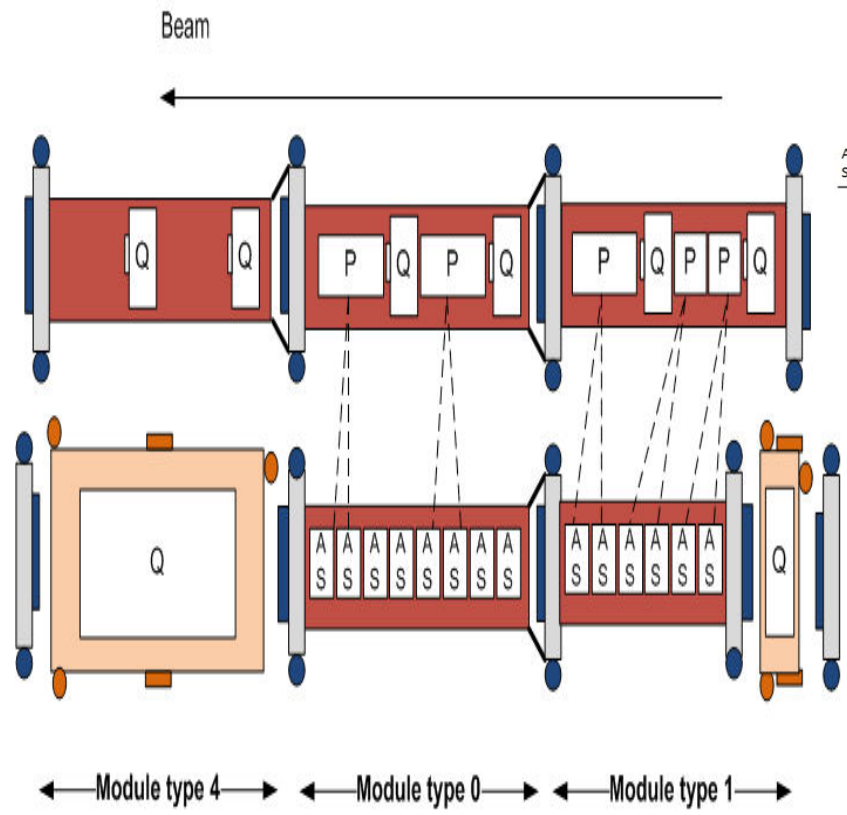

Test module representative of all module types integrating all various components: RF structures, quadrupoles, instrumentation, alignment, stabilisation, vacuum, etc....

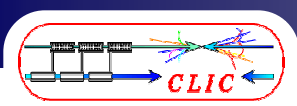

## TBL



- Full line installed
- Up to 8 PETS should be installed before the end of the year

# CLIC Drive Beam RF System – issues:

- Reminder of the main issues for the Drive Beam RF system:
  - **Very large total power** ( $\approx 23$  GW peak, 170 MW average)  
What power source? Optimum size of individual power source?  
This was addressed in the last ACE.
  - **Phase stability (jitter <50 fs)**
  - **Overall efficiency!**
  - **Cost!**
- Summary from last ACE: **Trends:**
  - MBK 10 MW ... 20 MW
    - 10 MW available today (X-FEL, ILC)
    - “smaller” klystrons make reliability and serviceability easier
  - **... remained to be done:**
    - Make group delay of acc. structure = length of delay loop
    - Redesign structures to optimize for beam dynamics requirements

# Reminder: from last year's ACE

## Existing: ILC 1.3 GHz MBK's (10MW, 1.5 ms, 10 Hz)

1. CPI: VKL-8301B (6 beam): 10.2 MW, 66.3 %, 49.3 dB gain
2. Thales: TH 1801 (7 beam): 10.1 MW, 63%, 48 dB gain
3. Toshiba: E3736 (6 beam): 10.4 MW, 66 %, 49 dB gain

1.



26th May 2009

2.



4th CLIC Advisory Committee (CLIC-ACE)

3.



7

# New structure design (R. Wegner)

Scaled from 3 GHz:

Outer  $\varnothing$ : 522 mm

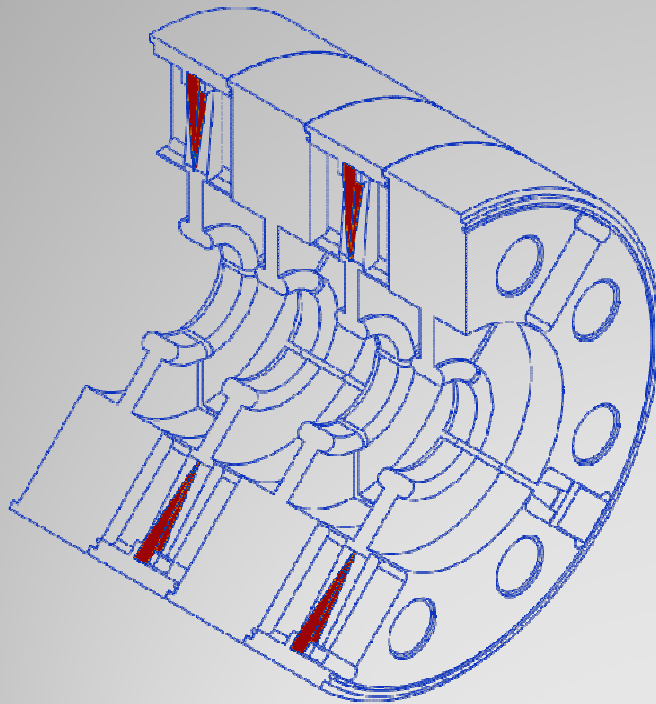

New design:

Outer  $\varnothing$ : < 300 mm

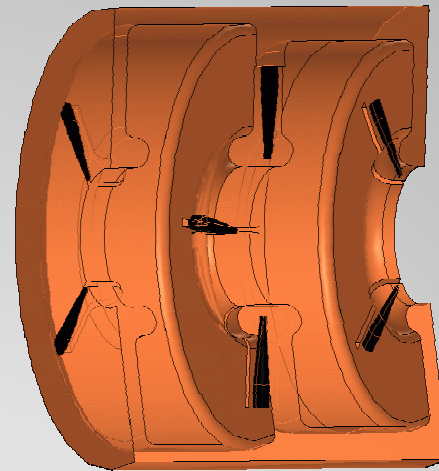

New idea (A. Grudiev):  
dampers inside the slots!

This new approach has been verified:

acc. mode

$$Q_0 = 2.2 \cdot 10^4, \quad Q_{\text{ext}} = 3.7 \cdot 10^7$$

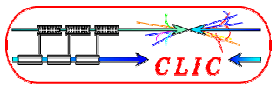

# Drive Beam Phase Tolerance

- Integrated simulations have been performed with PLACET and GUINEA-PIG of main linac, BDS and beam-beam
  - system is assumed to be perfectly aligned (to determine BDS bandwidth effect)
  - assuming target emittance at BDS

- Resulting luminosity loss is about 2% for

$$\frac{\sigma_G}{G} \approx 1 \times 10^{-3}$$

and

$$\sigma_\phi \approx 0.3^\circ$$

$$\frac{\Delta\mathcal{L}}{\mathcal{L}} \approx 0.01 \left[ \left( \frac{\sigma_{\phi,coh}}{0.2^\circ} \right)^2 + \left( \frac{\sigma_{\phi,inc}}{0.8^\circ} \right)^2 + \left( \frac{\sigma_{G,coh}}{0.75 \cdot 10^{-3}G} \right)^2 + \left( \frac{\sigma_{G,inc}}{2.2 \cdot 10^{-3}G} \right)^2 \right]$$

- Main beam current needs to be stable to  $\approx 0.1$ – $0.2\%$

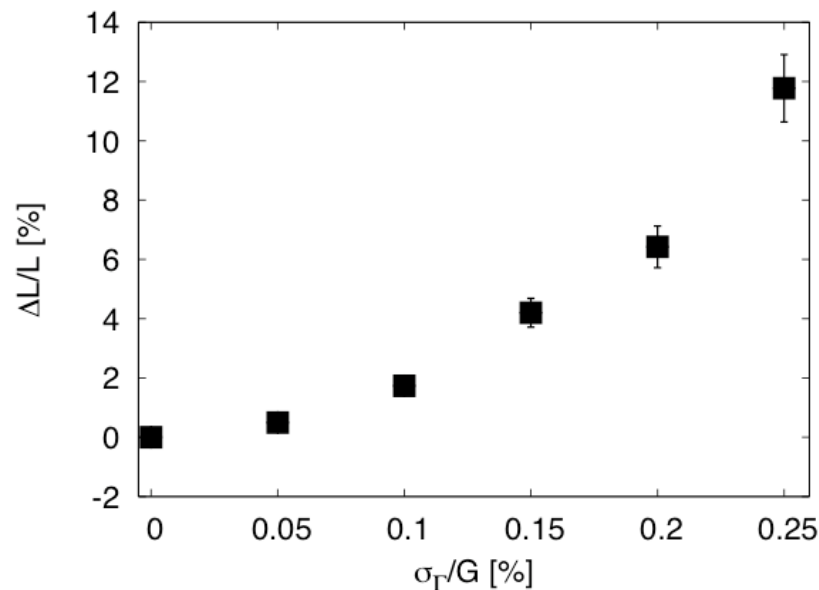
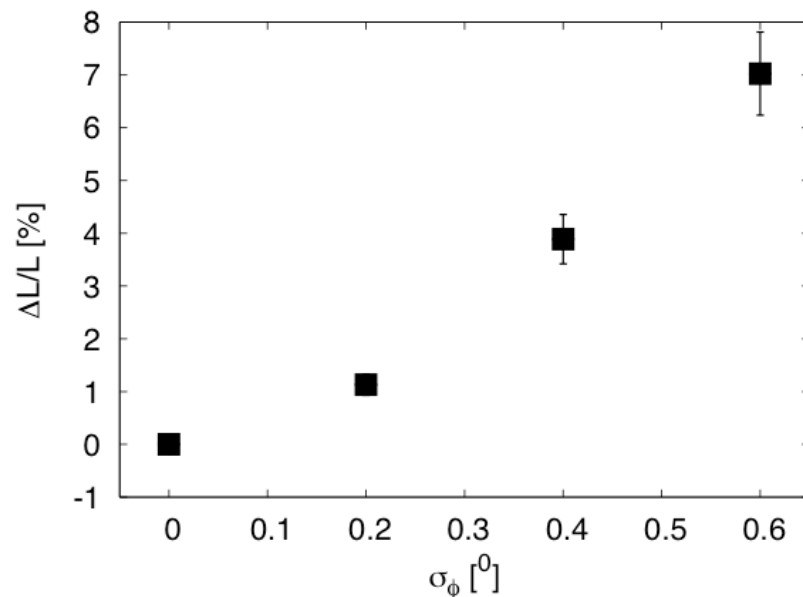

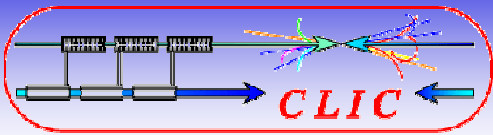
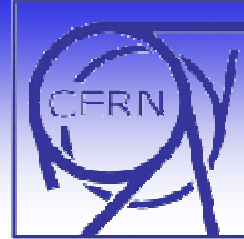

## Energy and phase stability requirements in CLIC

- Drive beam phase jitter leads to luminosity drop.
- $\Delta\varphi$  at 1 GHz causes 12  $\Delta\varphi$  at 12 GHz!
- Requirement at 1GHz (order of magnitude):
  - drive beam phase jitter  $<0.02^\circ$  ( $3.5\text{E-}4$ , 50 fs)
  - drive beam energy jitter  $<\mathcal{O}(1\text{E-}4)$(With a feed-forward, this may be relaxed by a factor 10!)
- Requirement at 12GHz (order of magnitude):
  - drive beam phase jitter  $<0.2^\circ$  ( $3.5\text{E-}3$ , 50 fs)
  - drive beam energy jitter  $<\mathcal{O}(1\text{E-}4)$

See: Erk Jensen, 4th CLIC Advisory Committee (CLIC-ACE)



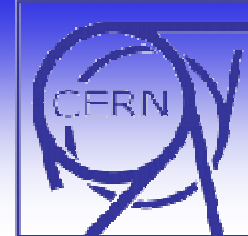
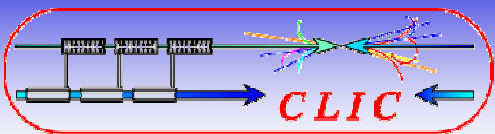

# Phase measurements in CLIC

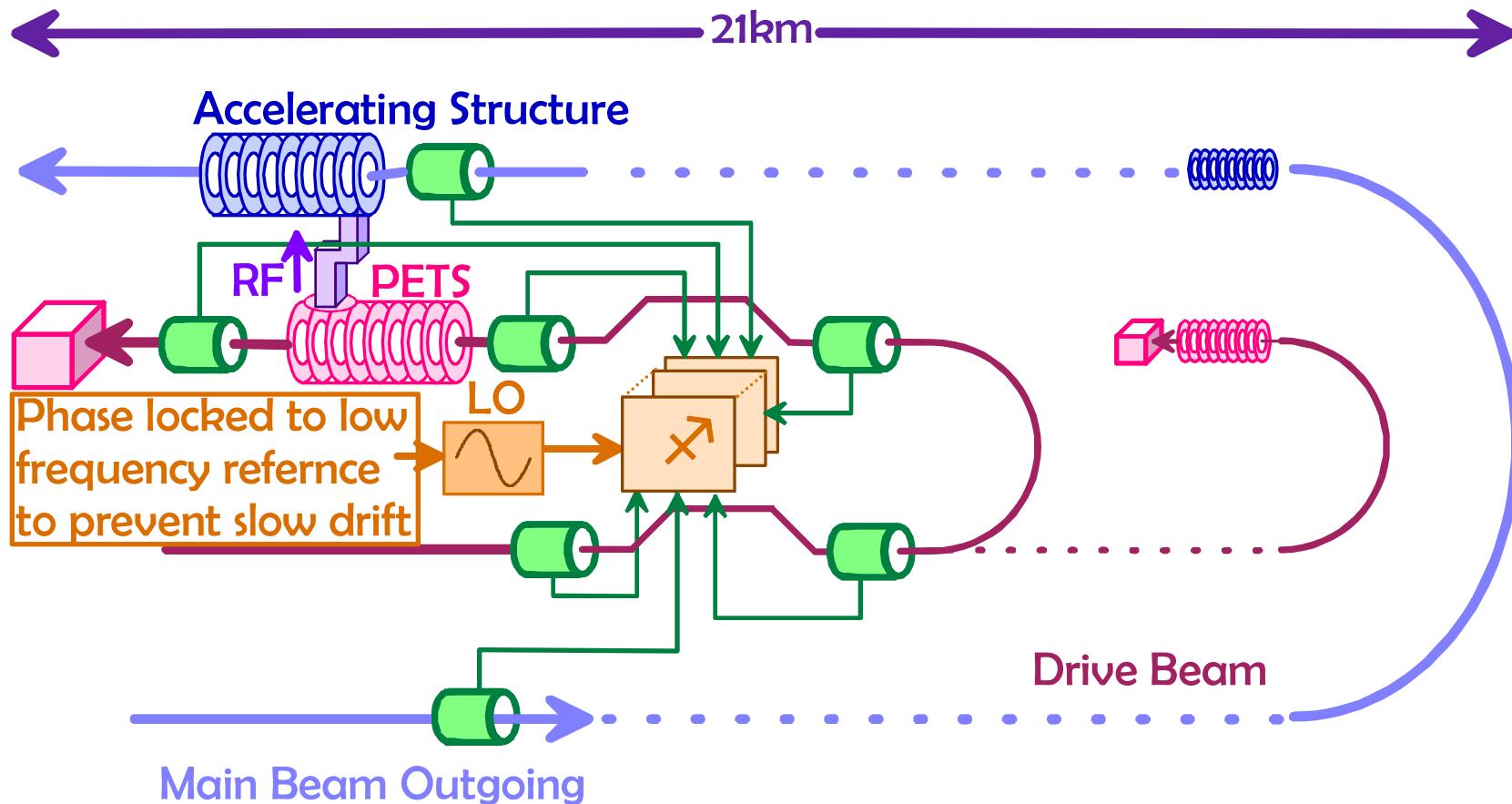

# Sensors

## Characterisation commercial devices

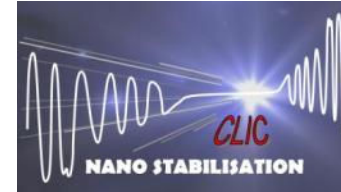

Reference test bench

Low technical noise lab  
TT1 (< 2 nm rms 1Hz)

Instrument Noise determination

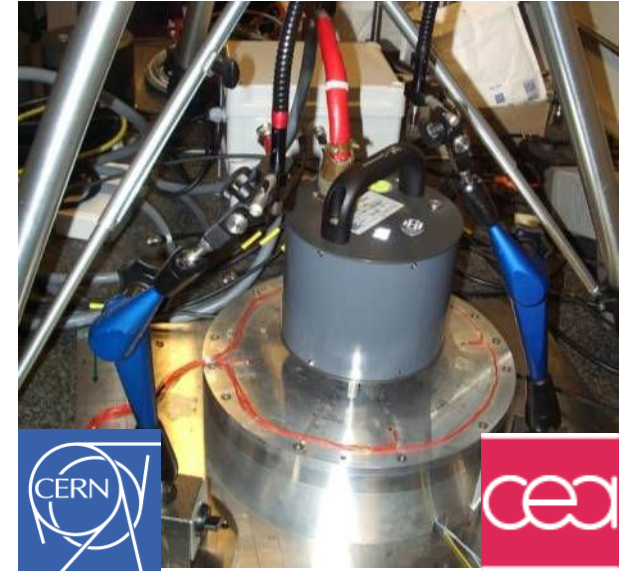
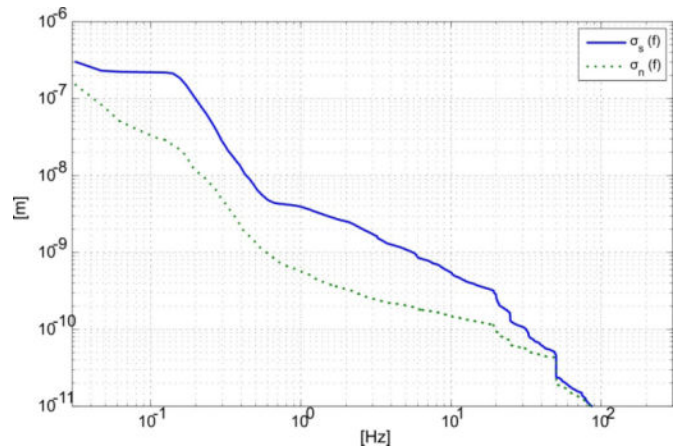

Sensitivity and resolution testing  
Cross axis sensitivity

Model Seismometer: Transfer Function

Characterisation signal analysis (resolution,  
filtering, window, PSD, integration, coherence,...)

C. Collette

Ref. Talk C. Hauviller 4 th CLIC-ACE  
+ STABILISATION WG

# CERN option: Steps toward performance demonstration

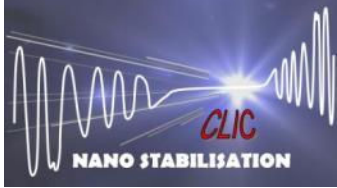

## 2. Stabilisation **single d.o.f. with type 1 weight** ("tripod")

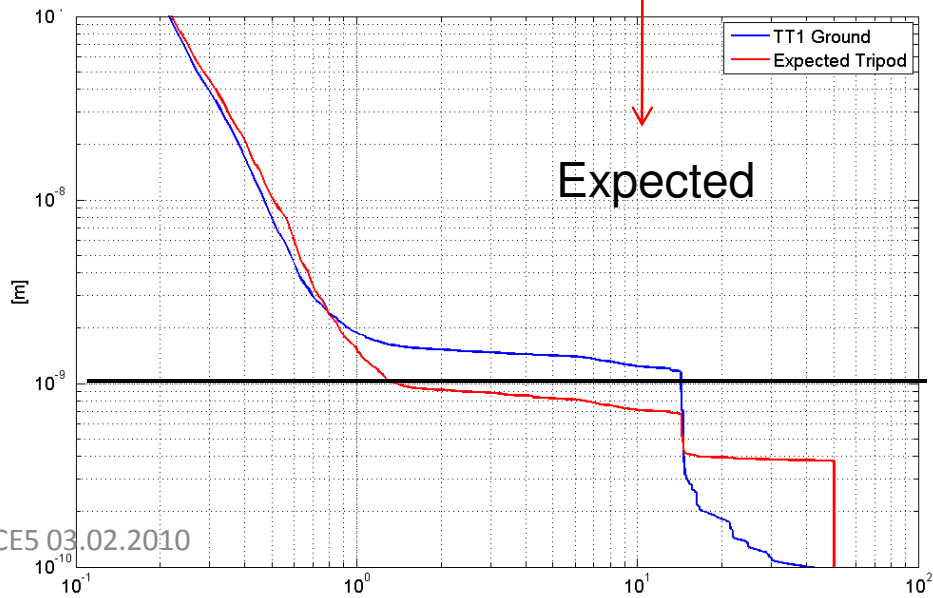
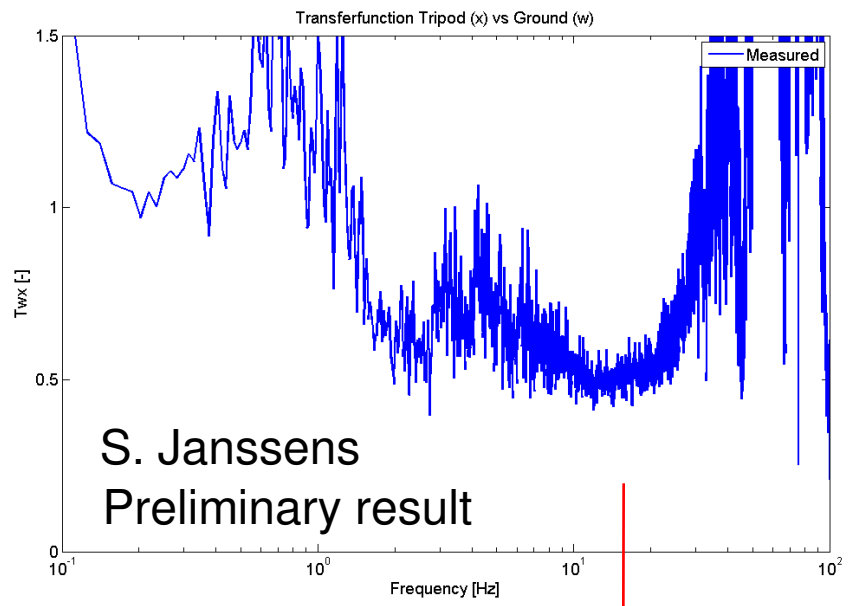
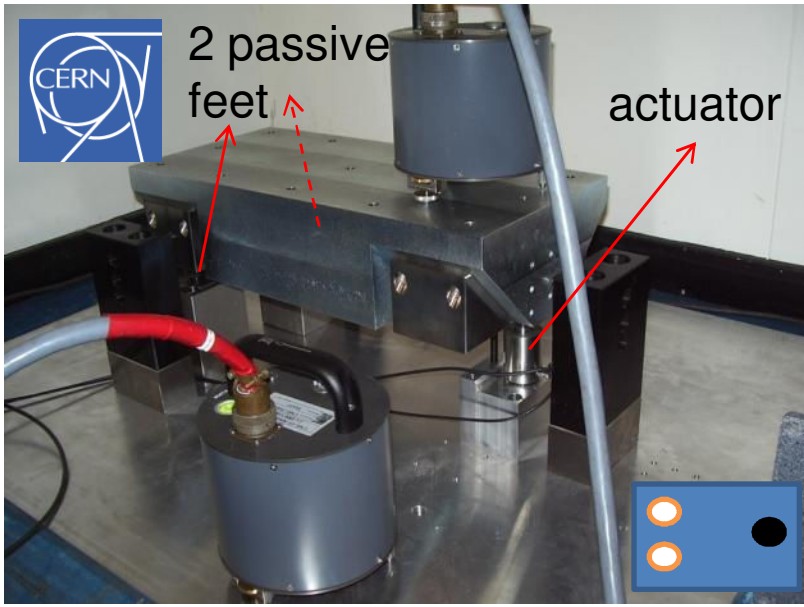

- Will be improved :
- Optimise controller design (Tuning, Combine feedback with feedforward)
  - Improve resolution (actuator, DAQ)
  - Avoid low frequency resonances in structure and contacts
  - Noise budget on each step, ADC and DAC noise

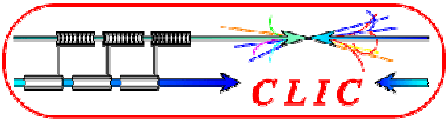

# Final Quadrupole Stabilisation

## Experimental results @ LAPP (Bolzon&al.)

- set-up is not the same as at CLIC IP
- engineering is emerging
- performance of sensor in residual detector field needs to be explored

Impact on beam-beam jitter if correlation neglected

With mechanical feedback

Pulse-to-pulse beam-beam feedback added

Feed-forward on beam based on vibration sensors added

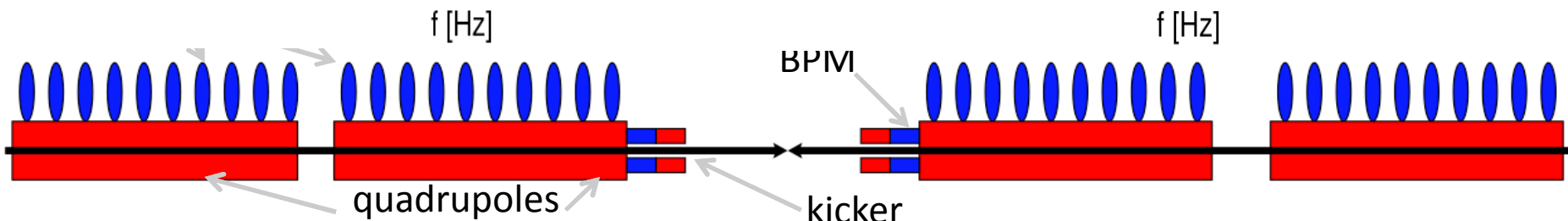
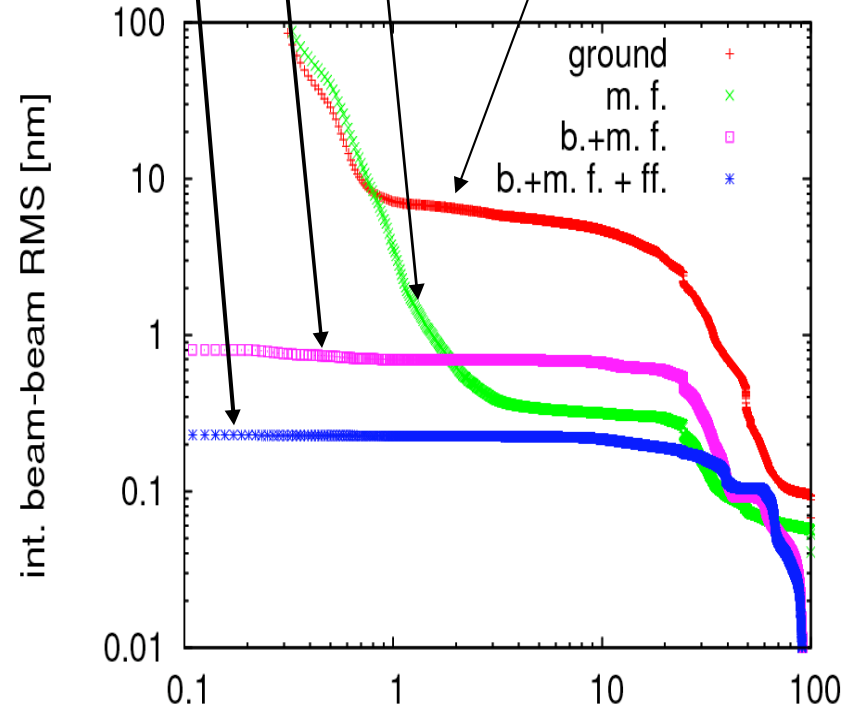
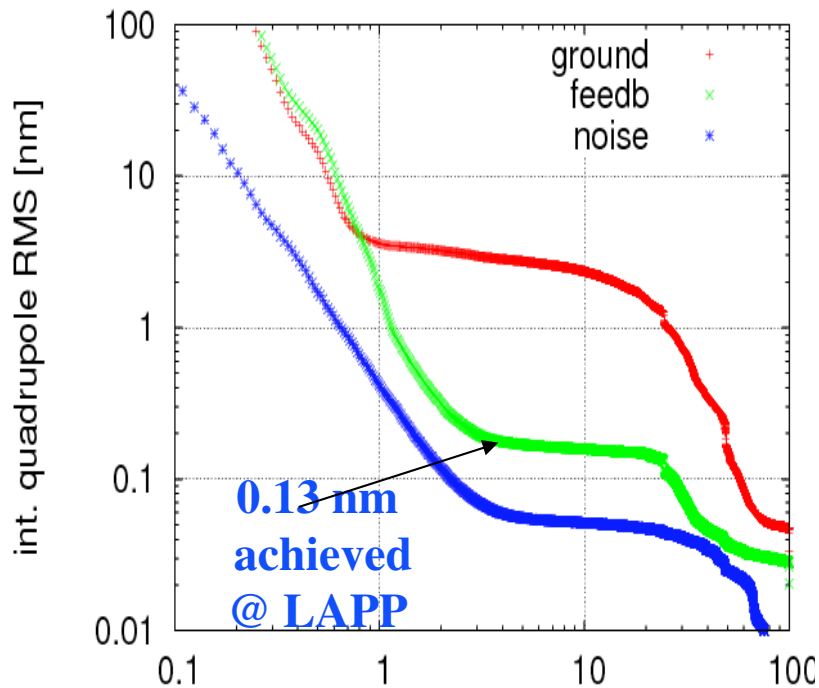

Some features of the project  
(high gradient stuff in the next talk)

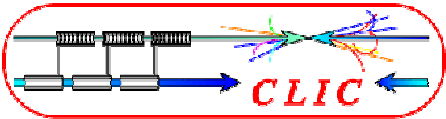

# *Conceptual Design Report*

*Coordinator/editor: H.Schmickler*

*Contribution/Authors by CLIC collaborators*

<https://edms.cern.ch/nav/CERN-0000060014/AB-003131>

## **3 volumes: similar to ILC CDR:**

- **Vol1: Executive Summary**
- **Vol2: The CLIC accelerator and site facilities**
- **Vol3: The CLIC physics and detectors**  
including detailed value Estimate

specific contribution in vol. 2&3; summary in vol. 1.

## **Editorial Board for Volume 2:**

**H.Schmickler (chair), N.Phinney/SLAC, N.Toge/KEK,**  
**Outline with Abstract and suggested main author distributed**  
**Presentation and discussion at Collaboration Board (05/02/10)**

**Vol 3 under responsibility of LCD project (L.Linssen)**

# World-wide CLIC&CTF3 Collaboration

[http://clic-meeting.web.cern.ch/clic-meeting/CTF3\\_Coordination\\_Mtg/Table\\_MoU.htm](http://clic-meeting.web.cern.ch/clic-meeting/CTF3_Coordination_Mtg/Table_MoU.htm)



## 34 Institutes from 19 countries

Aarhus University (Denmark)  
 Ankara University (Turkey)  
 Argonne National Laboratory (USA)  
 Athens University (Greece)  
 BINP (Russia)  
 CERN  
 CIEMAT (Spain)  
 Cockcroft Institute (UK)  
 Gazi Universities (Turkey)

Helsinki Institute of Physics (Finland)  
 IAP (Russia)  
 IAP NASU (Ukraine)  
 INFN / LNF (Italy)  
 Instituto de Fisica Corpuscular (Spain)  
 IRFU / Saclay (France)  
 Jefferson Lab (USA)  
 John Adams Institute (UK)

JINR (Russia)  
 Karlsruhe University (Germany)  
 KEK (Japan)  
 LAL / Orsay (France)  
 LAPP / ESIA (France)  
 NCP (Pakistan)  
 North-West. Univ. Illinois (USA)  
 Patras University (Greece)  
 Polytech. University of Catalonia (Spain)

PSI (Switzerland)  
 RAL (UK)  
 RRCAT / Indore (India)  
 SLAC (USA)  
 Thrace University (Greece)  
 Tsinghua University (China)  
 University of Oslo (Norway)  
 Uppsala University (Sweden)

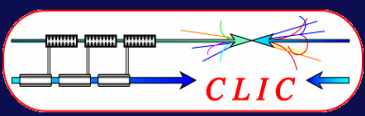
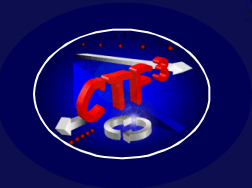

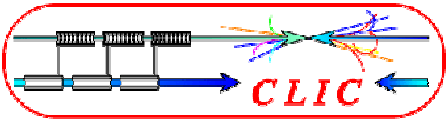

# CLIC Organisational Chart

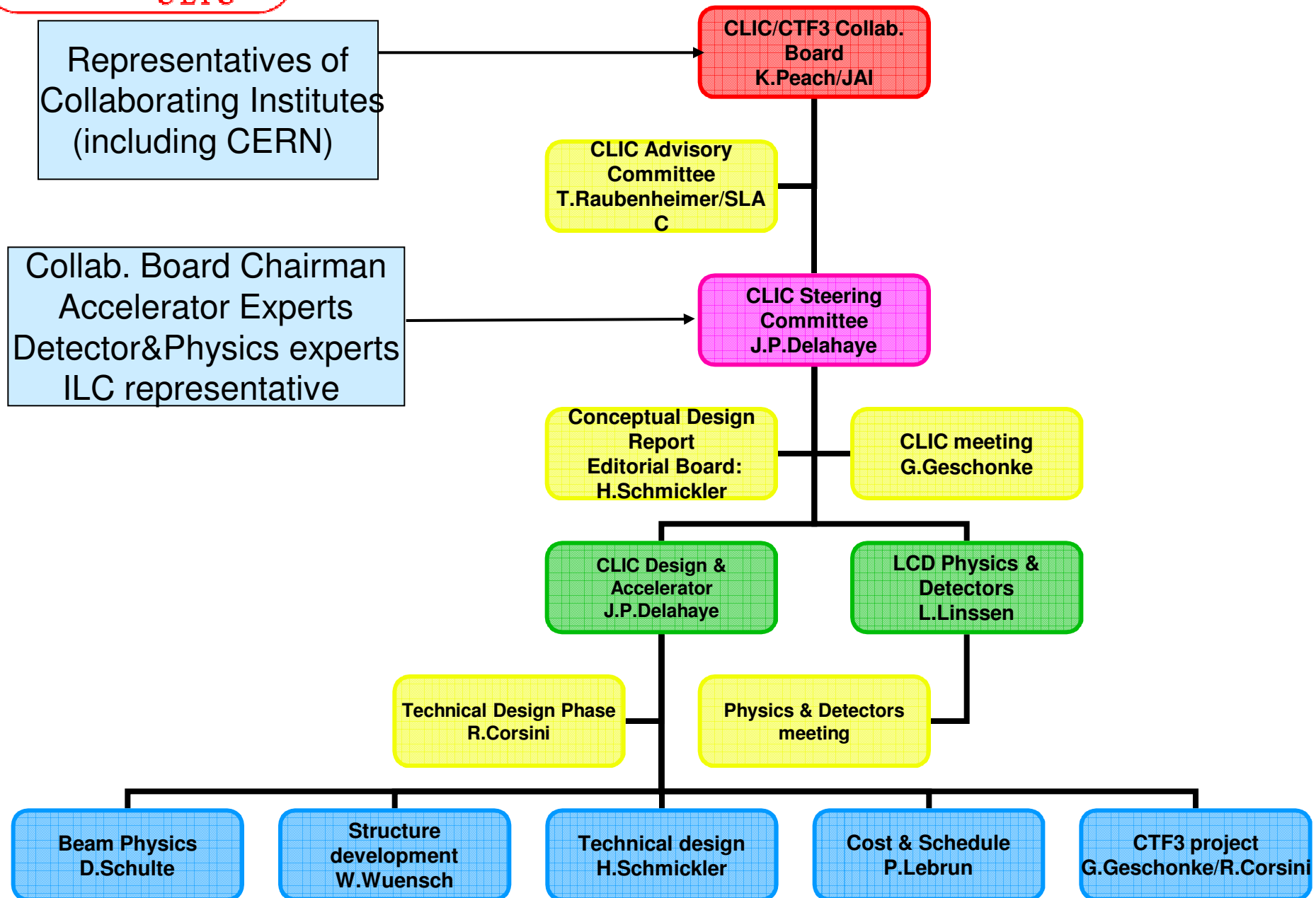



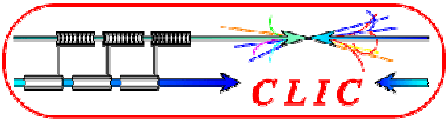

# *CLIC Site and Documentation*

- **CLIC web site:**

<http://clic-study.web.cern.ch/CLIC-Study/>

- **CLIC Committees and Working Groups reflecting the CLIC organization:**

[http://clic-study.web.cern.ch/CLIC-Study/Mtgs\\_Wkg\\_Grp.htm](http://clic-study.web.cern.ch/CLIC-Study/Mtgs_Wkg_Grp.htm)

- **CLIC Collaborations:**

<http://clic-study.web.cern.ch/CLIC-Study/Collaborations.htm>

- **Documentation on EDMS:**

<https://edms.cern.ch/nav/CERN-0000060014>