

Supports assembly for barrel insertion chassis and patch panels

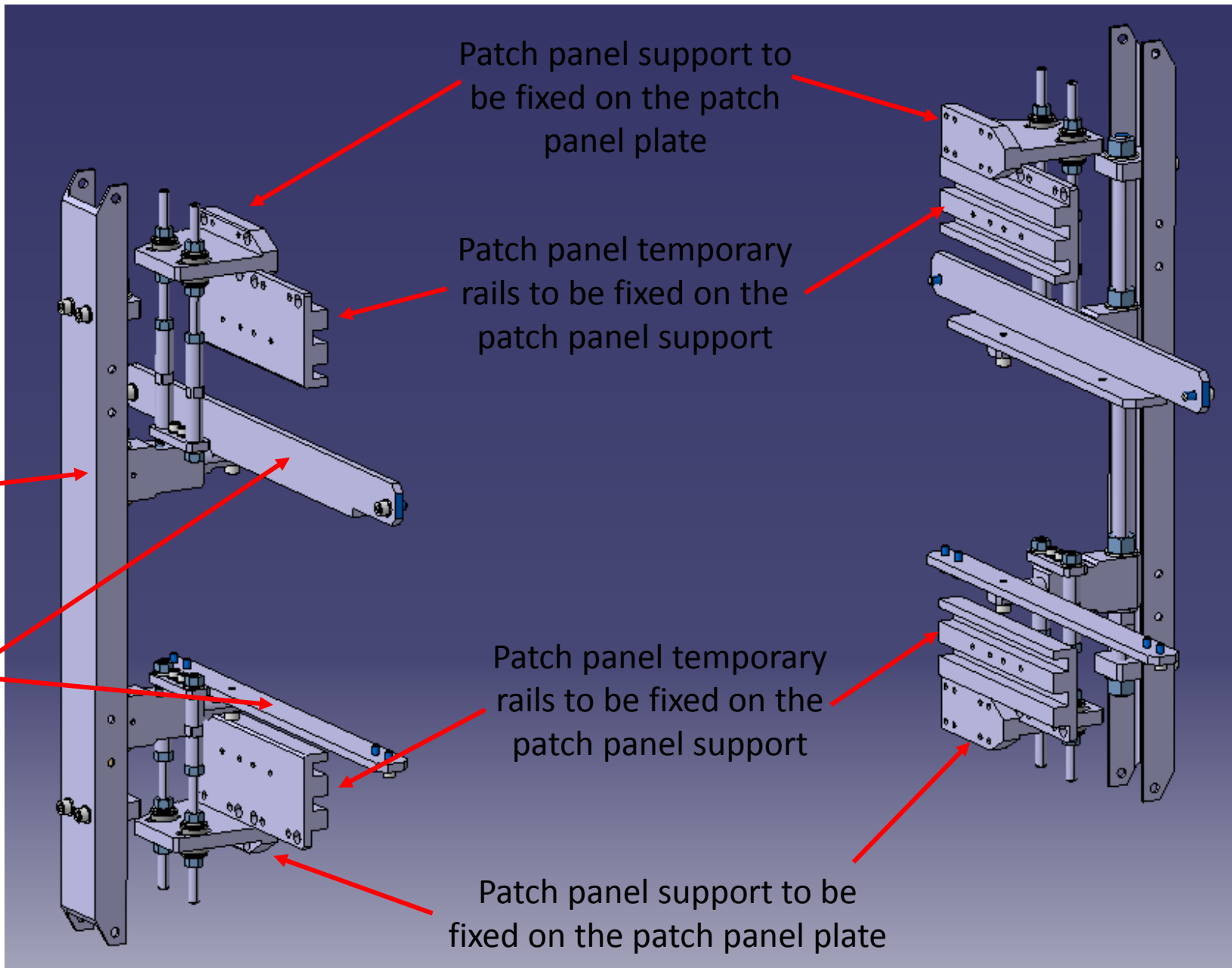

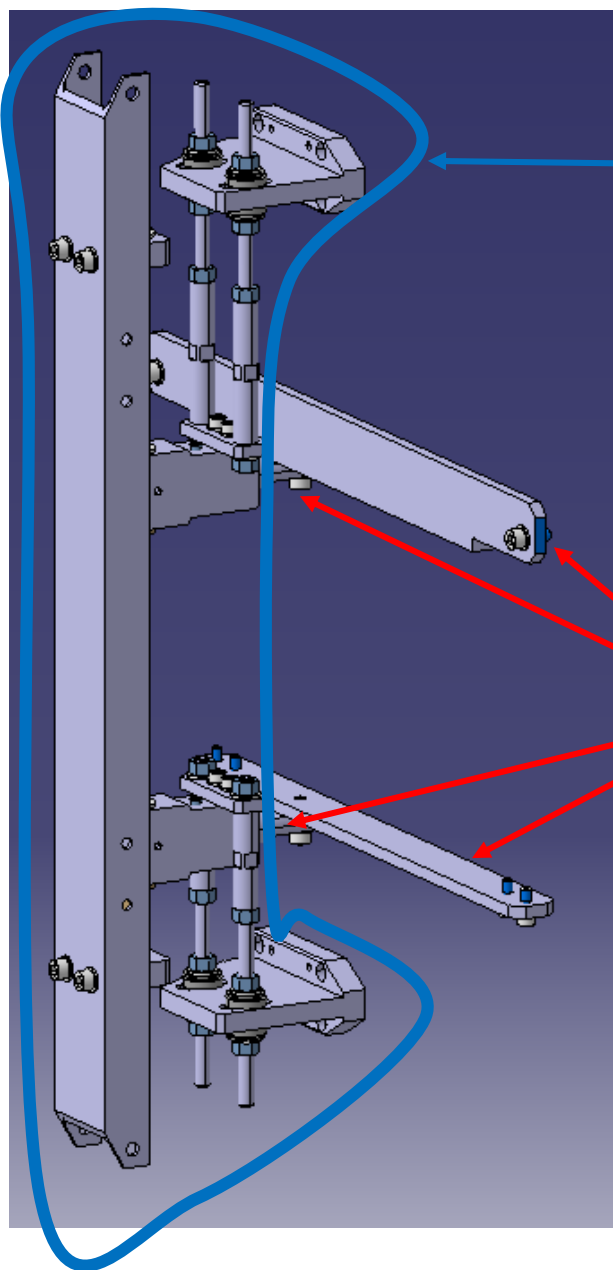

Supports for patch panels, to be kept

Supports for barrel insertion chassis, to be removed with the chassis

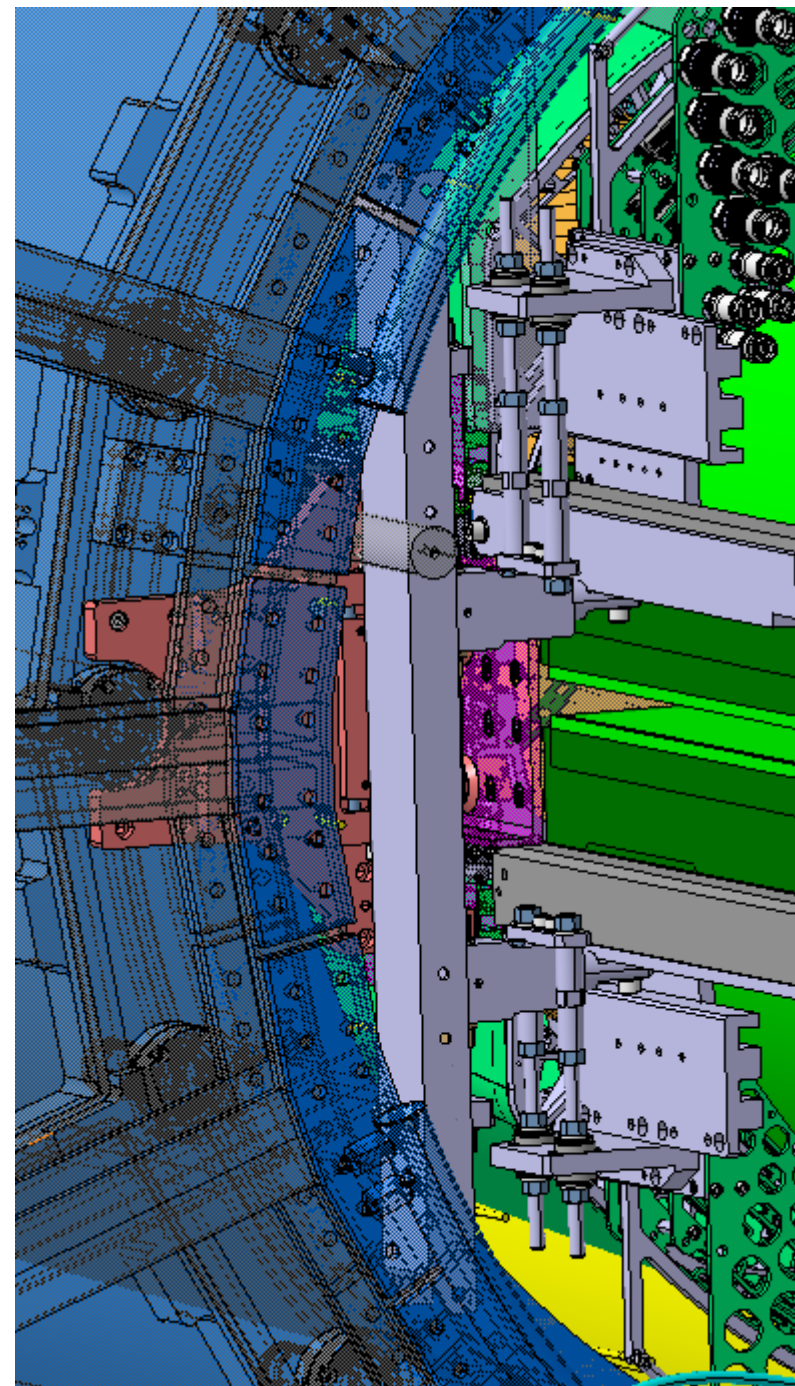

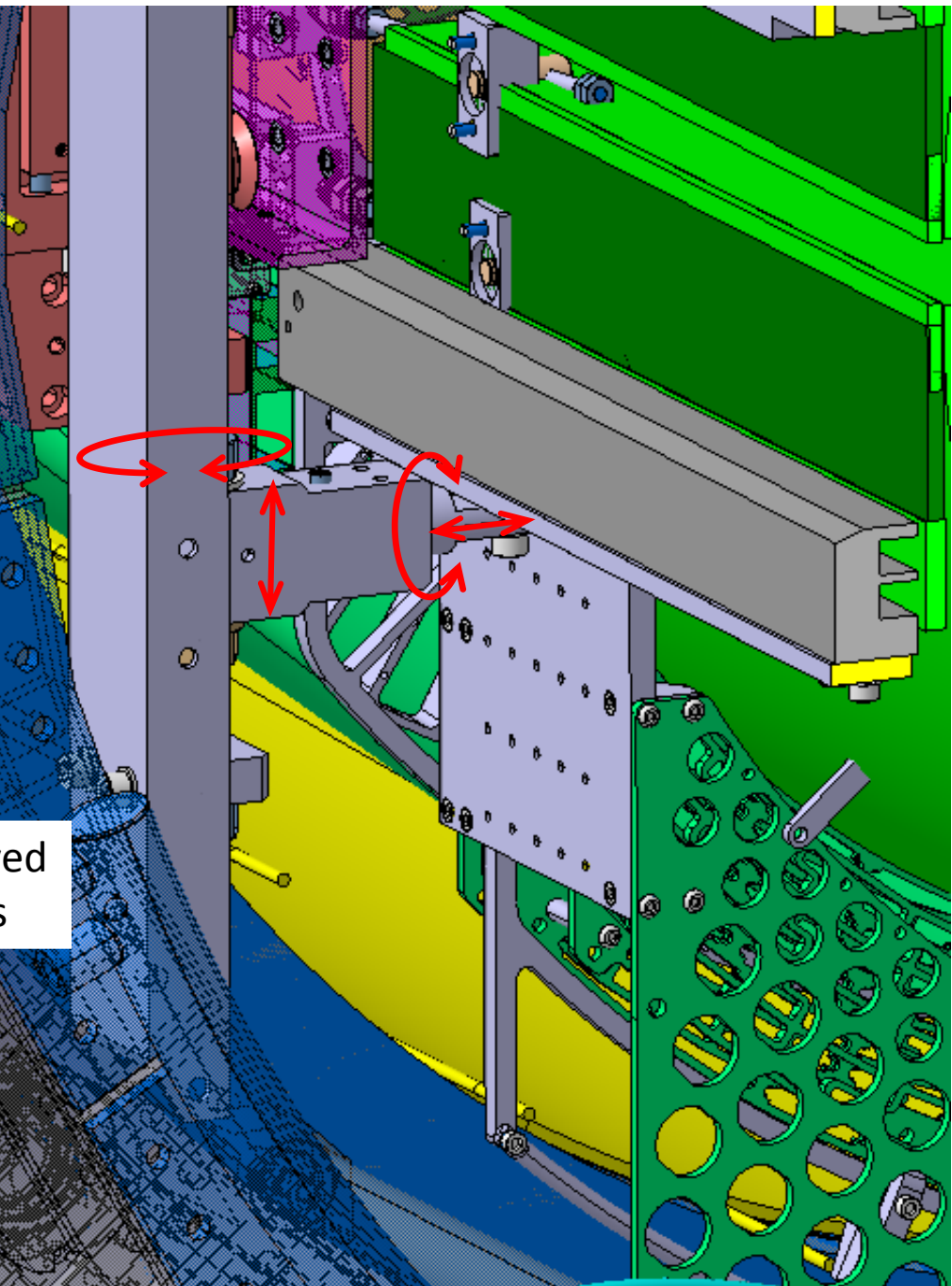
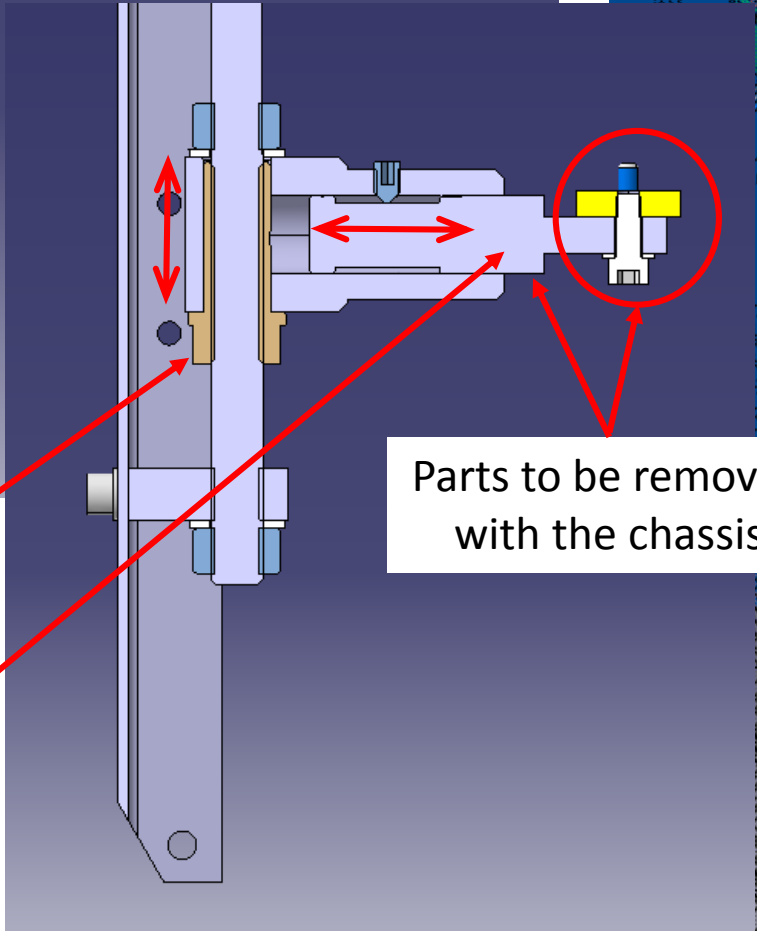
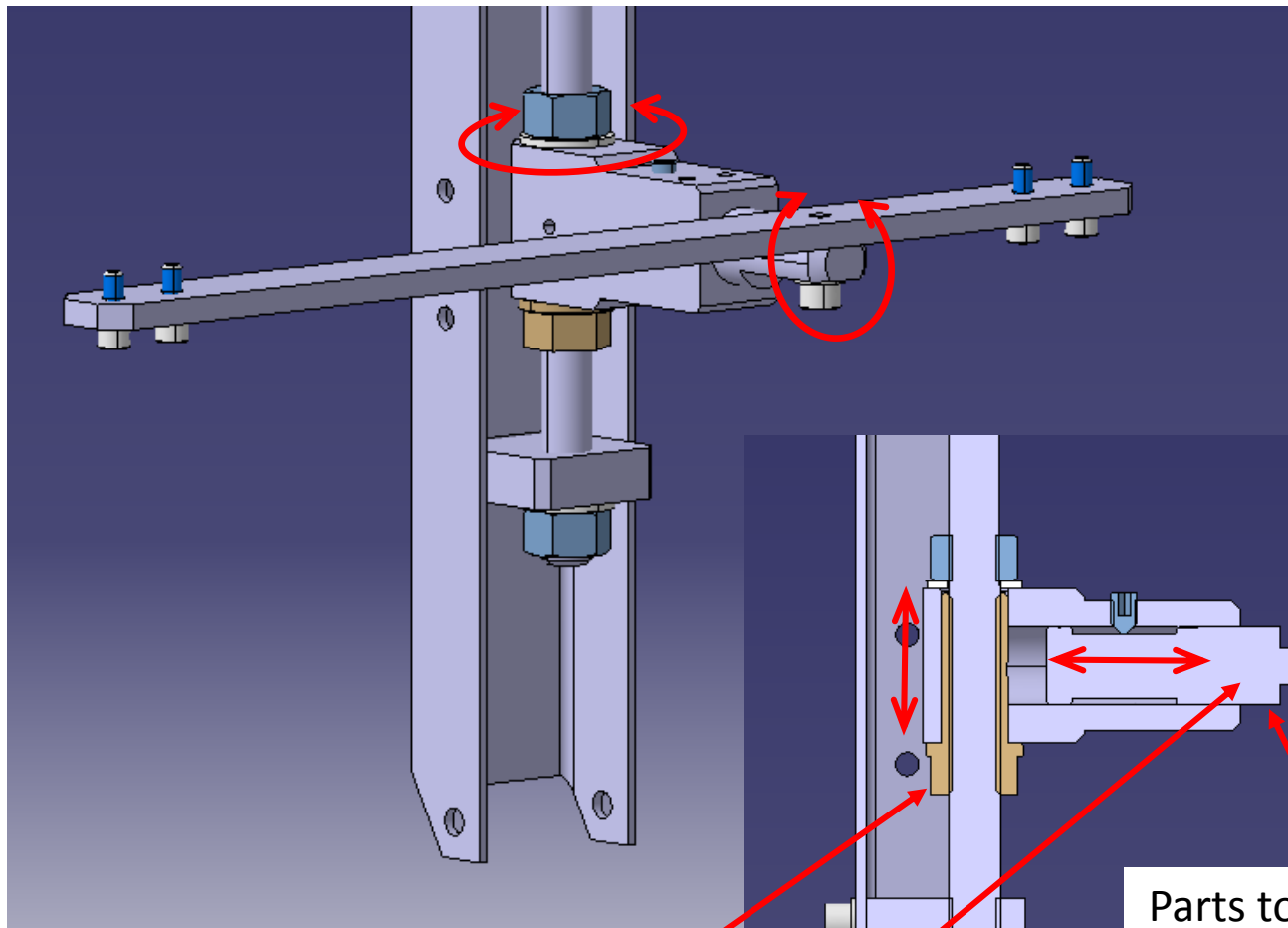

Bronze threaded axis, for high adjustment

Axis, for adjustment in radial and axis direction way + rotation

Parts to be removed with the chassis

Patch panels supports

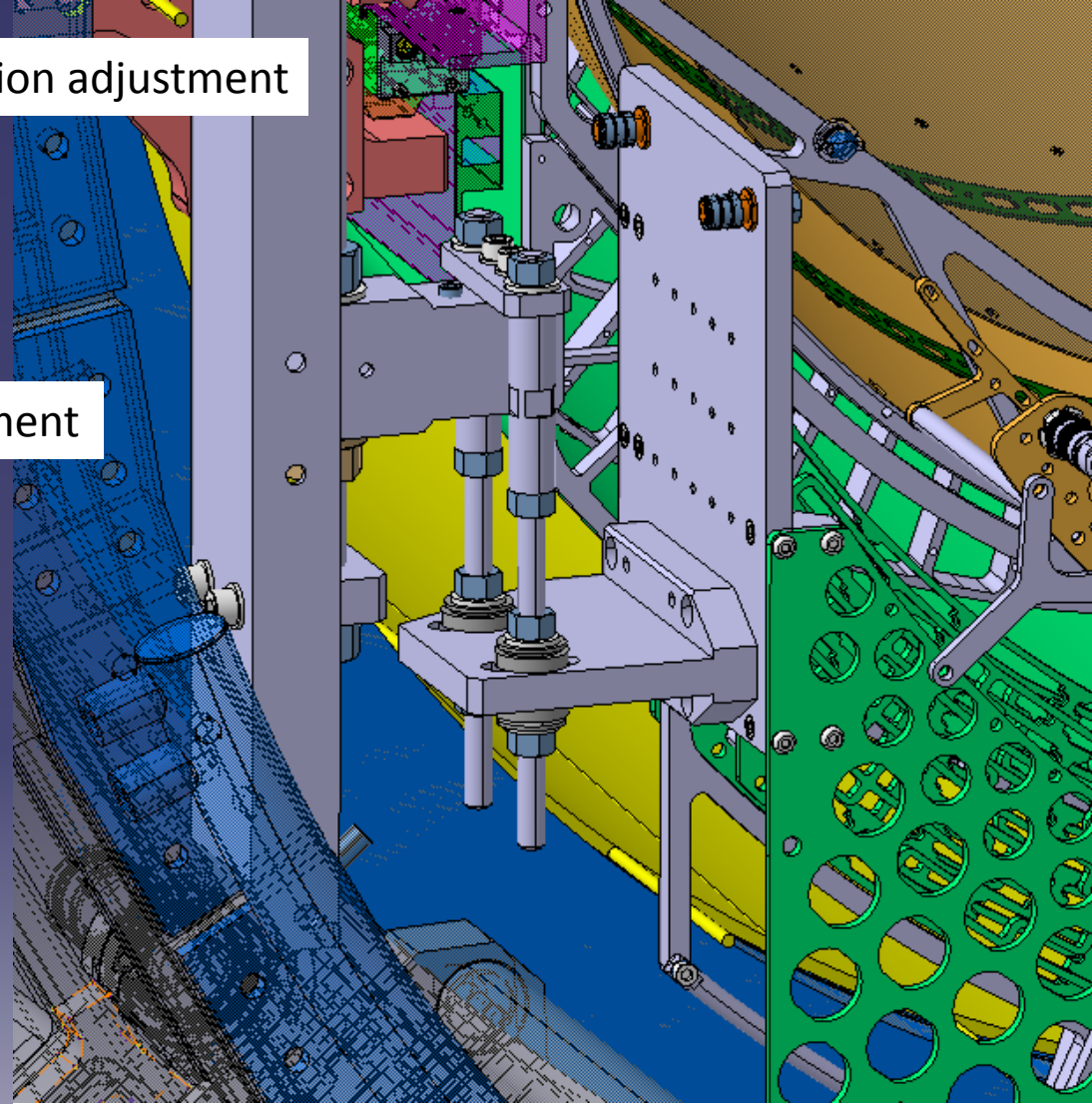
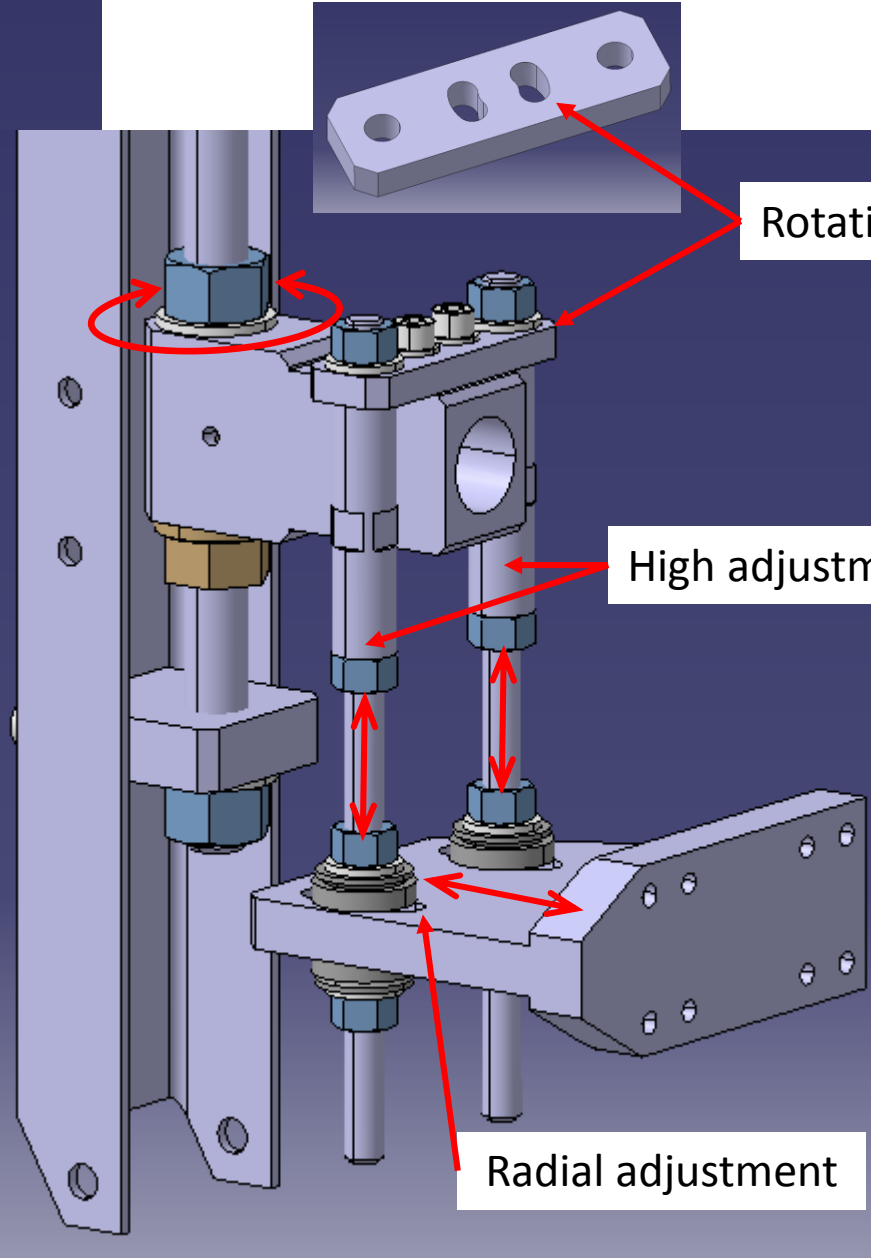
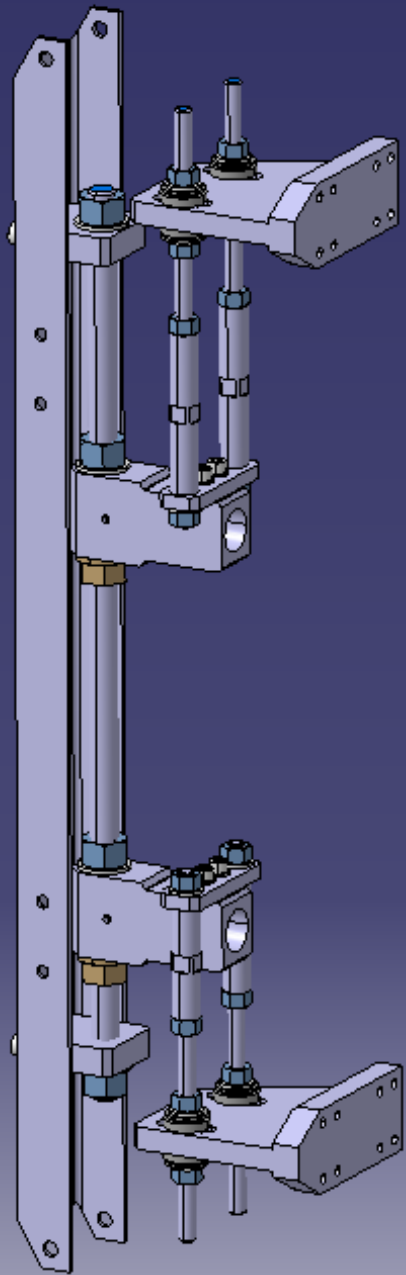

Patch panels supports

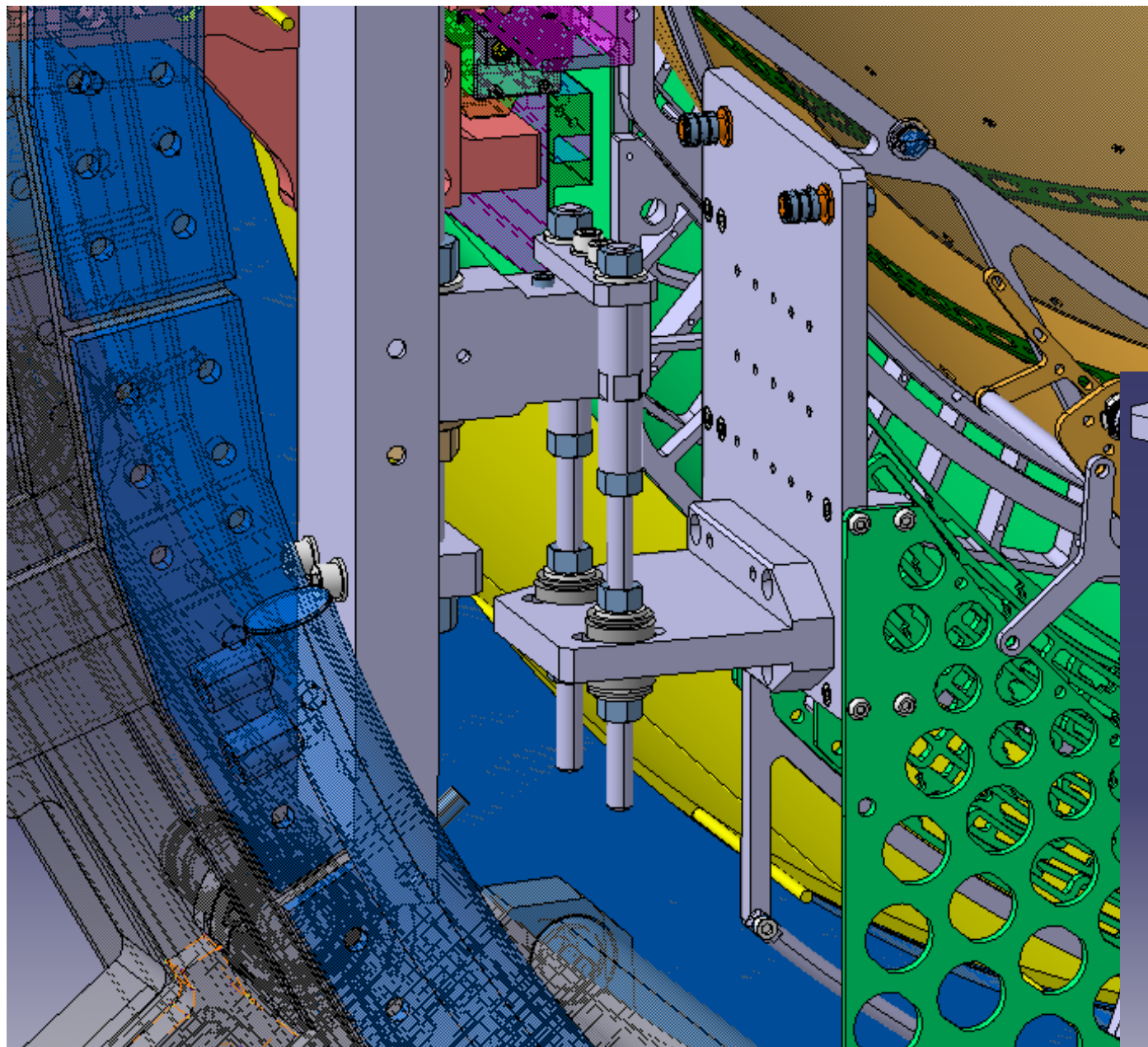

Fixation by 2 M8 screws, could be not enough for the weight and the cantilever apply during the patch panel insertion. Could be improved.

Patch panel position before final insertion

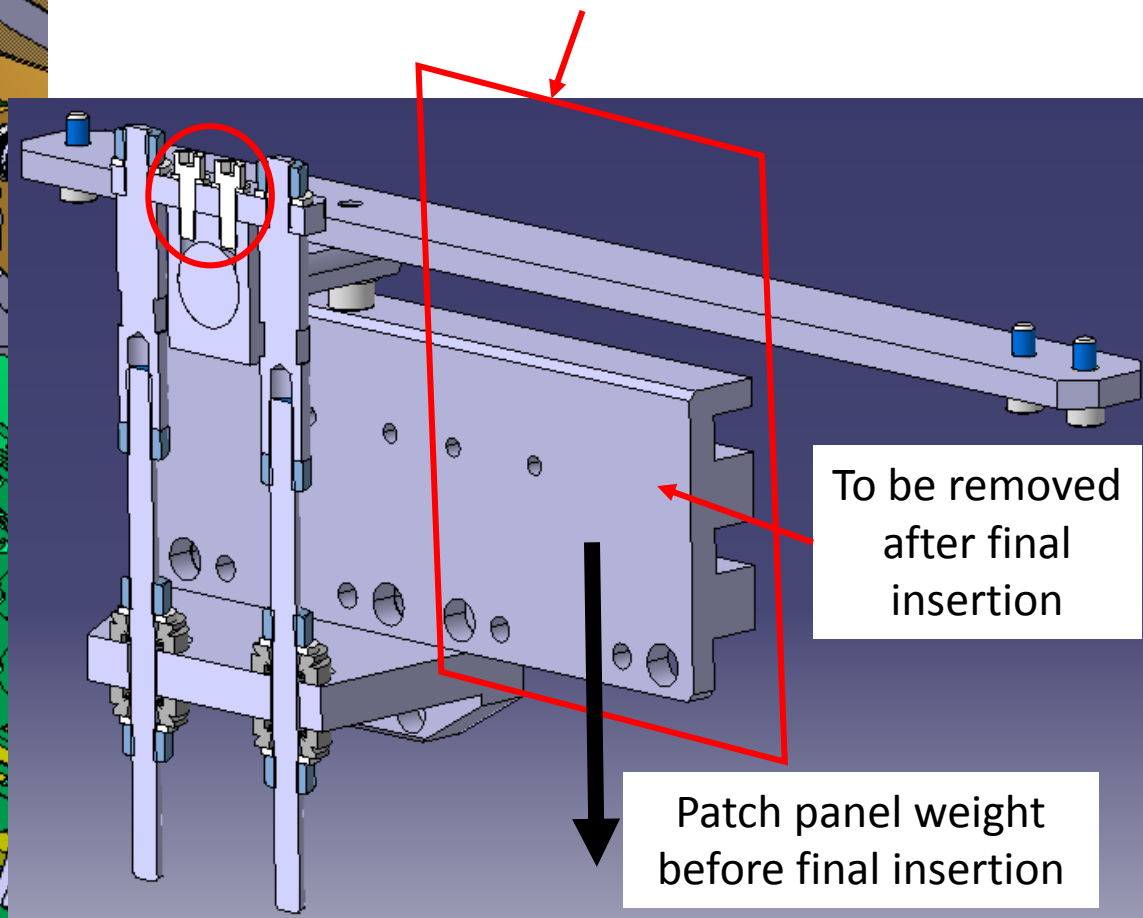

Patch panels supports VS targets

Top

Bottom

