

Particle Detectors

Summer Student Lectures 2010

Werner Riegler, CERN, werner.riegler@cern.ch

- ◆ **History of Instrumentation ↔ History of Particle Physics**
- ◆ **The 'Real' World of Particles**
- ◆ **Interaction of Particles with Matter**
- ◆ **Tracking with Gas and Solid State Detectors**
- ◆ **Calorimetry, Detector Systems**

Detectors based on Ionization

Gas detectors:

- **Wire Chambers**
- **Drift Chambers**
- **Time Projection Chambers**
- **Transport of Electrons and Ions in Gases**

Solid State Detectors

- **Transport of Electrons and Holes in Solids**
- **Si- Detectors**
- **Diamond Detectors**

Solid State Detectors

Gas Detectors

In gaseous detectors, a charged particle is liberating electrons from the atoms, which are freely bouncing between the gas atoms.

An applied electric field makes the electrons and ions move, which induces signals on the metal readout electrodes.

For individual gas atoms, the electron energy levels are discrete.

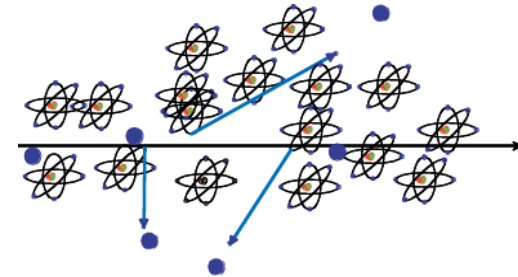

Solid State Detectors

In solids (crystals), the electron energy levels are in 'bands'.

Inner shell electrons, in the lower energy bands, are closely bound to the individual atoms and always stay with 'their' atoms.

In a crystal there are however energy bands that are still bound states of the crystal, but they belong to the entire crystal. Electrons in these bands and the holes in the lower band can freely move around the crystal, if an electric field is applied.

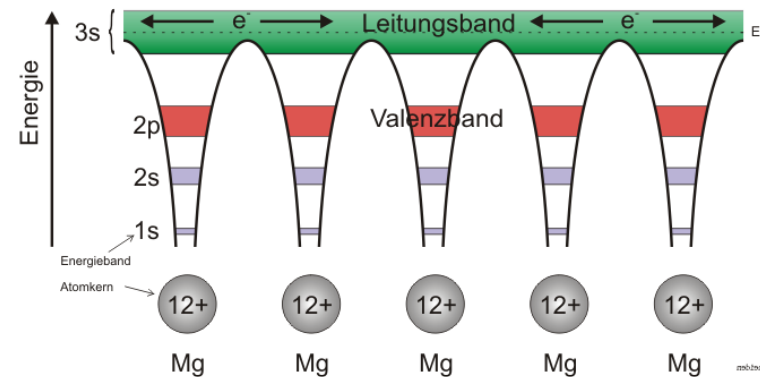

Solid State Detectors

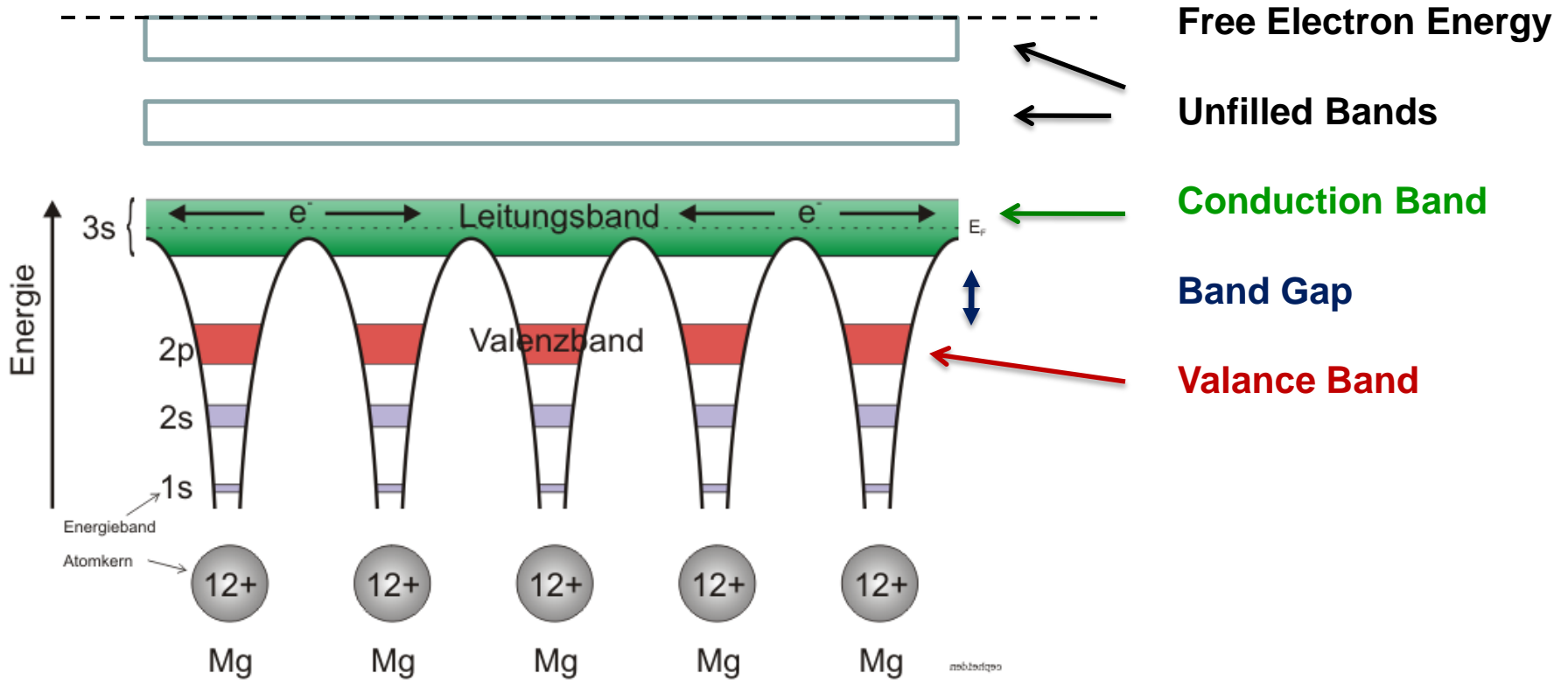

Conductor, Insulator, Semiconductor

In case the conduction band is filled the crystal is a conductor.

In case the conduction band is empty and 'far away' from the valence band, the crystal is an insulator.

In case the conduction band is empty but the distance to the valence band is small, the crystal is a semiconductor.

Solid State Detectors

Band Gap, e-h pair Energy

The energy gap between the last filled band – the valence band – and the conduction band is called band gap E_g .

The band gap of Diamond/Silicon/Germanium is 5.5, 1.12, 0.66 eV.

The average energy to produce an electron/hole pair for Diamond/Silicon/Germanium is 13, 3.6, 2.9eV.

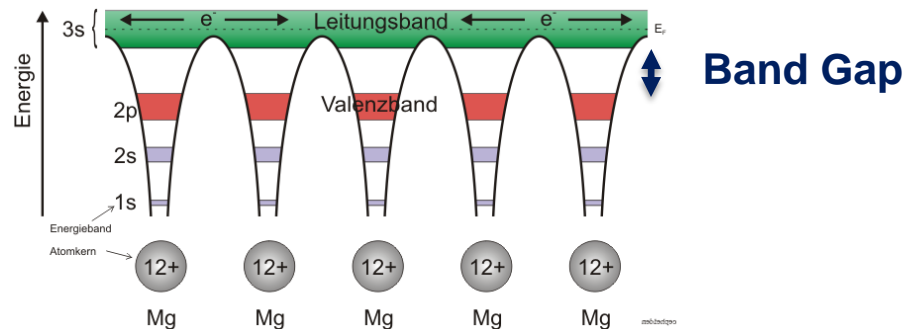

Temperature, Charged Particle Detection

In case an electron in the valence band gains energy by some process, it can be excited into the conduction band and a hole in the valence band is left behind.

Such a process can be the passage of a charged particle, but also thermal excitation → probability is proportional $\text{Exp}(-E_g/kT)$.

The number of electrons in the conduction band is therefore increasing with temperature i.e. the conductivity of a semiconductor increases with temperature.

Solid State Detectors

Electron, Hole Movement:

It is possible to treat electrons in the conduction band and holes in the valence band similar to free particles, but with an effective mass different from elementary electrons not embedded in the lattice.

This mass is furthermore dependent on other parameters such as the direction of movement with respect to the crystal axis. All this follows from the QM treatment of the crystal (solid state physics).

Cooling:

If we want to use a semiconductor as a detector for charged particles, the number of charge carriers in the conduction band due to thermal excitation must be smaller than the number of charge carriers in the conduction band produced by the passage of a charged particle.

Diamond ($E_g=5.5\text{eV}$) can be used for particle detection at room temperature,
Silicon ($E_g=1.12\text{ eV}$) and Germanium ($E_g=0.66\text{eV}$) must be cooled, or the free charge carriers must be eliminated by other tricks → doping → see later.

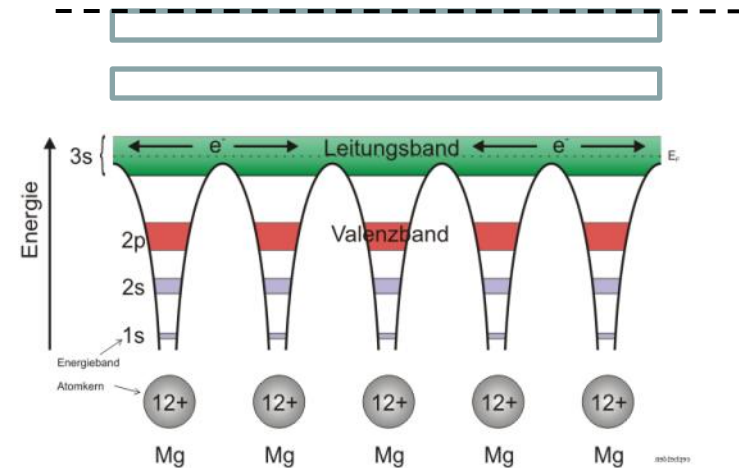

Solid State Detectors

Primary 'ionization':

The average energy to produce an electron/hole pair is:
Diamond (13eV), Silicon (3.6eV), Germanium (2.9eV)

Comparing to gas detectors, the density of a solid is about a factor 1000 larger than that of a gas and the energy to produce an electron/hole pair e.g. for Si is a factor 7 smaller than the energy to produce an electron-ion pair in Argon.

Solid State vs. Gas Detector:

The number of primary charges in a Si detector is therefore about 10^4 times larger than the one in gas → while gas detectors need internal charge amplification, solid state detectors don't need internal amplification.

While in gaseous detectors, the velocity of electrons and ions differs by a factor 1000, the velocity of electrons and holes in many semiconductor detectors is quite similar → very short signals.

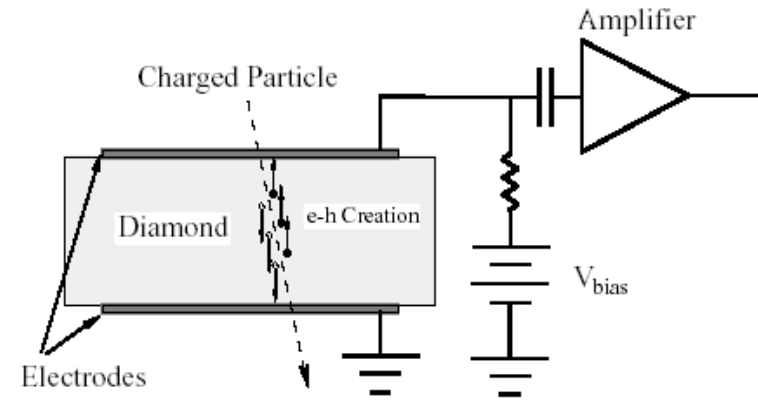

Diamond → A solid state ionization chamber

Diamond Detector

Typical thickness – a few 100 μm .

<1000 charge carriers/cm³ at room temperature due to large band gap.

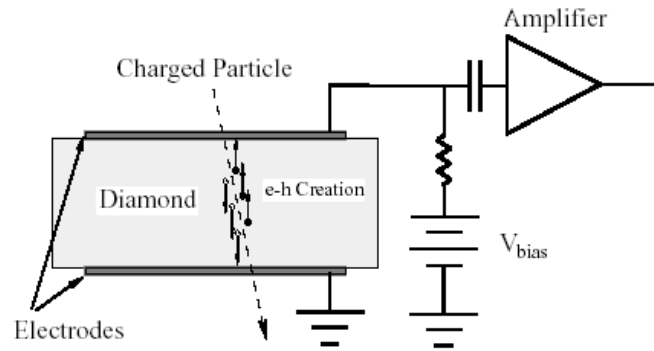

Velocity:

$\mu_e=1800 \text{ cm}^2/\text{Vs}$, $\mu_h=1600 \text{ cm}^2/\text{Vs}$

Velocity = μE , 10kV/cm $\rightarrow v=180 \mu\text{m}/\text{ns} \rightarrow$ Very fast signals of only a few ns length !

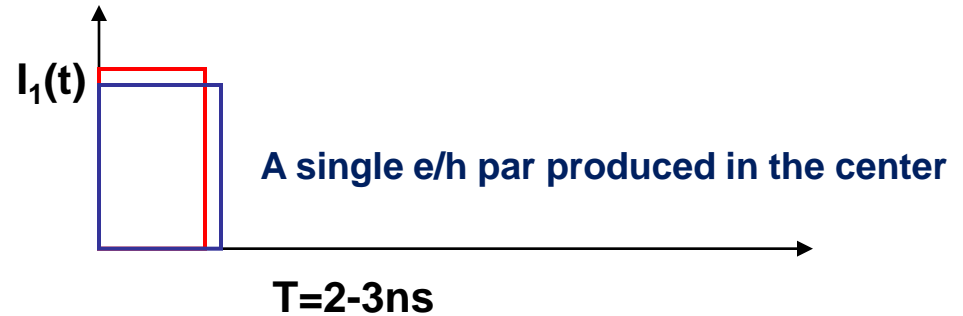
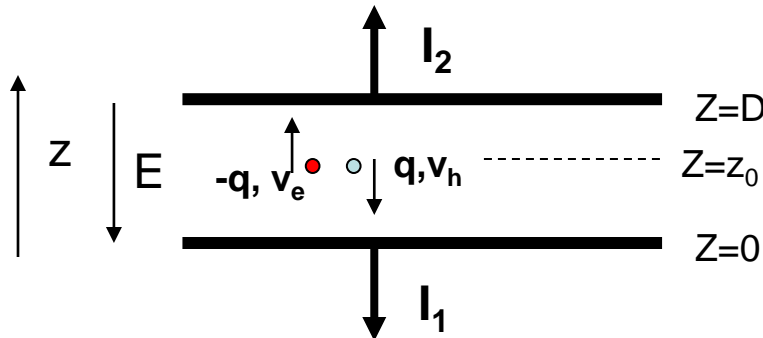

Diamond Detector

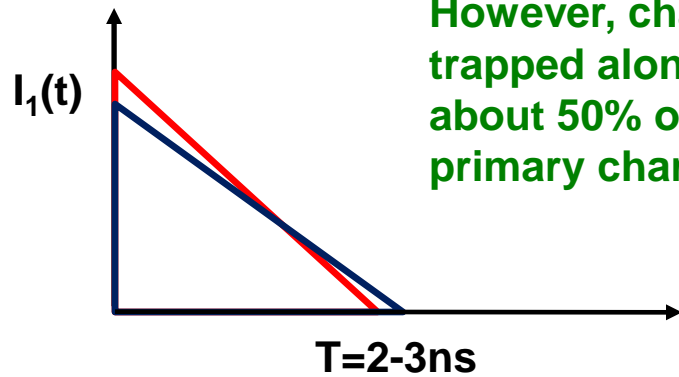
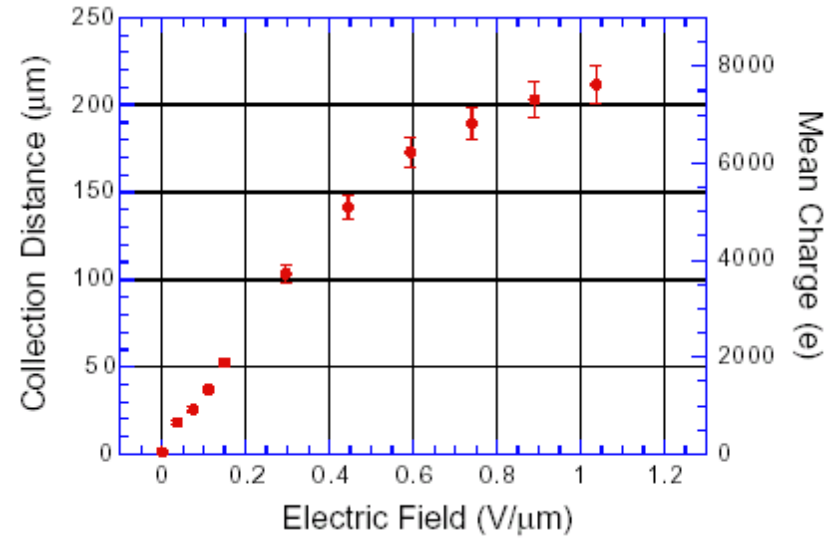
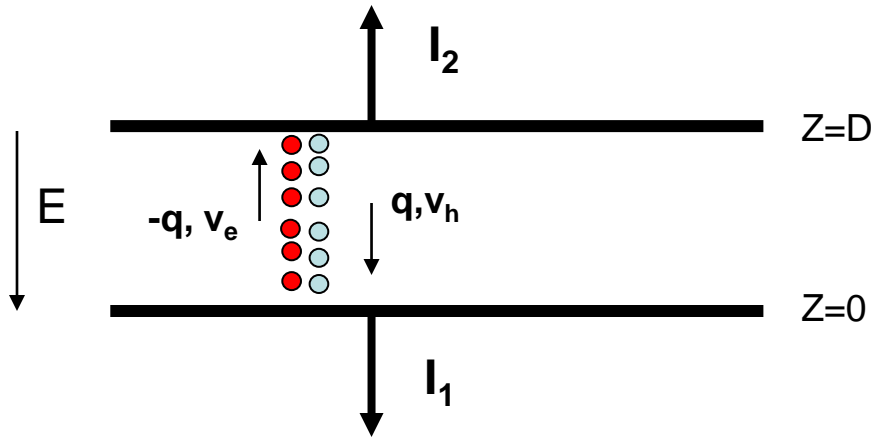

However, charges are trapped along the track, only about 50% of *produced* primary charge is *induced* \rightarrow

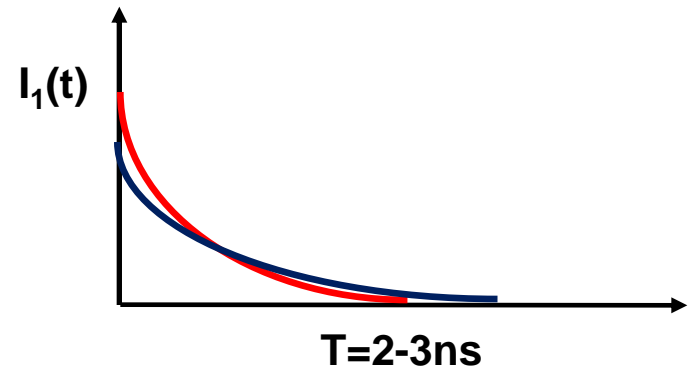

Silicon Detector

Velocity:

$\mu_e=1450 \text{ cm}^2/\text{Vs}$, $\mu_h=505 \text{ cm}^2/\text{Vs}$, 3.63eV per e-h pair.

~33000 e/h pairs in 300 μm of silicon.

However: Free charge carriers in Si:

T=300 K: e,h = $1.45 \times 10^{10} / \text{cm}^3$ but only 33000 e/h pairs in 300 μm produced by a high energy particle.

Why can we use Si as a solid state detector ???

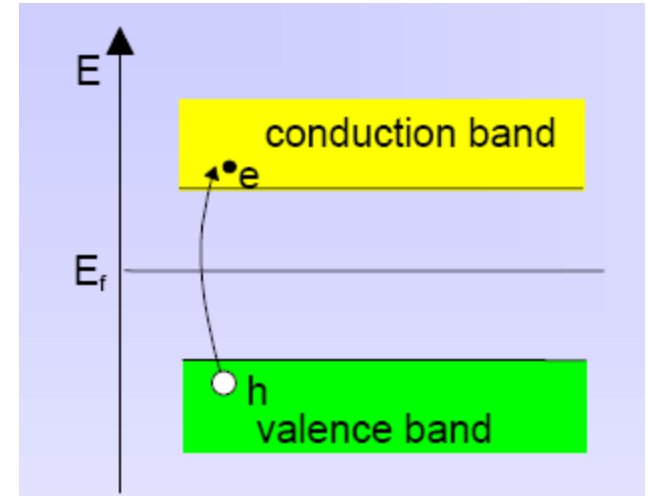

Doping of Silicon

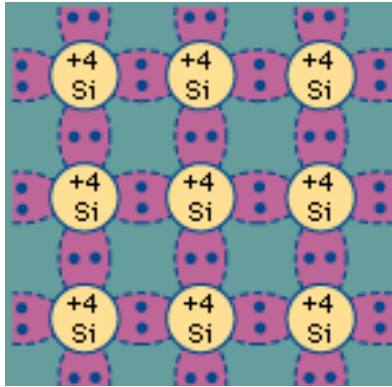

doping

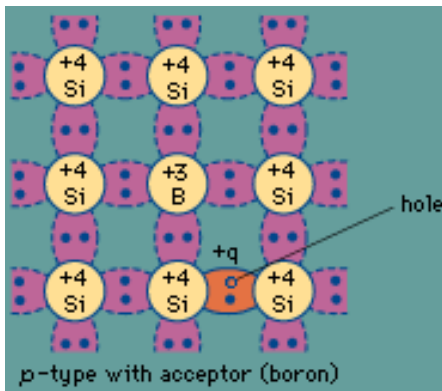
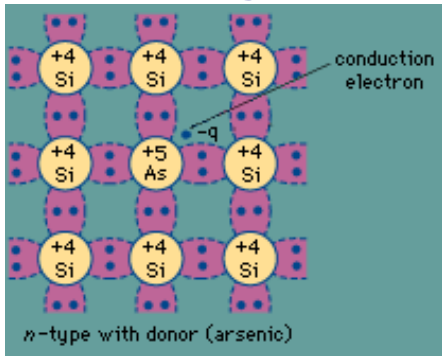

In a silicon crystal at a given temperature the number of electrons in the conduction band is equal to the number of holes in the valence band.

Doping Silicon with Arsen (+5) it becomes an n-type conductor (more electrons than holes).

Doping Silicon with Boron (+3) it becomes a p-type conductor (more holes than electrons).

Bringing p and n in contact makes a diode.

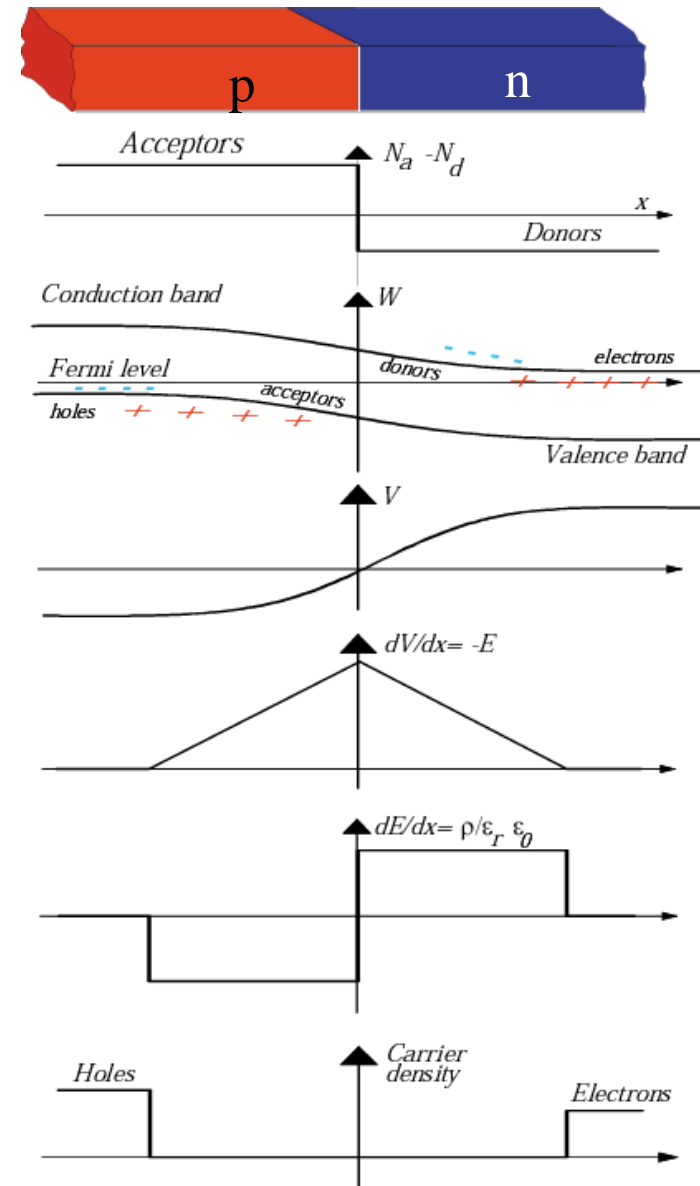

Si-Diode used as a Particle Detector !

At the p-n junction the charges are depleted and a zone free of charge carriers is established.

By applying a voltage, the depletion zone can be extended to the entire diode → highly insulating layer.

An ionizing particle produces free charge carriers in the diode, which drift in the electric field and induce an electrical signal on the metal electrodes.

As silicon is the most commonly used material in the electronics industry, it has one big advantage with respect to other materials, namely highly developed technology.

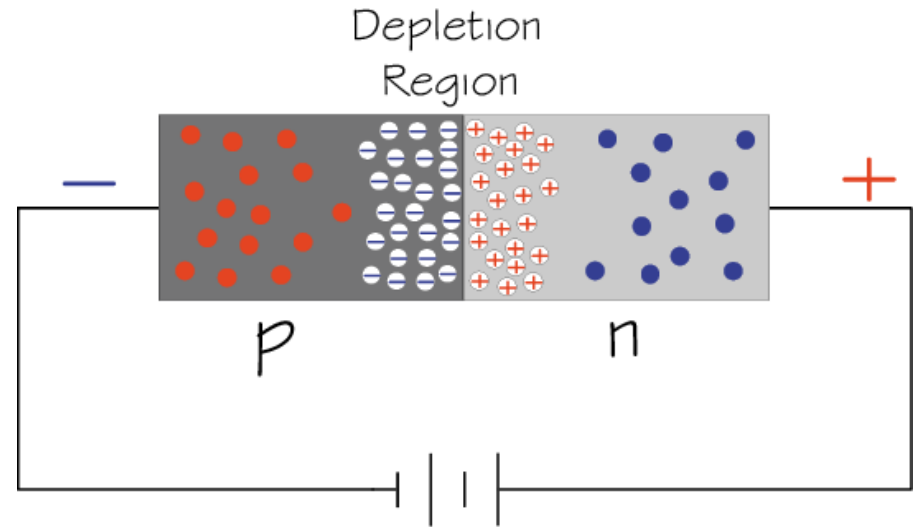

- Electron
- ⊕ Positive ion from removal of electron in n-type impurity
- ⊖ Negative ion from filling in p-type vacancy
- Hole

Under-Depleted Silicon Detector

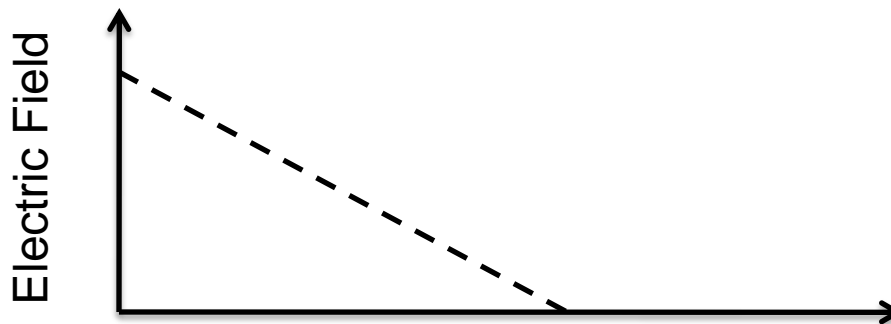
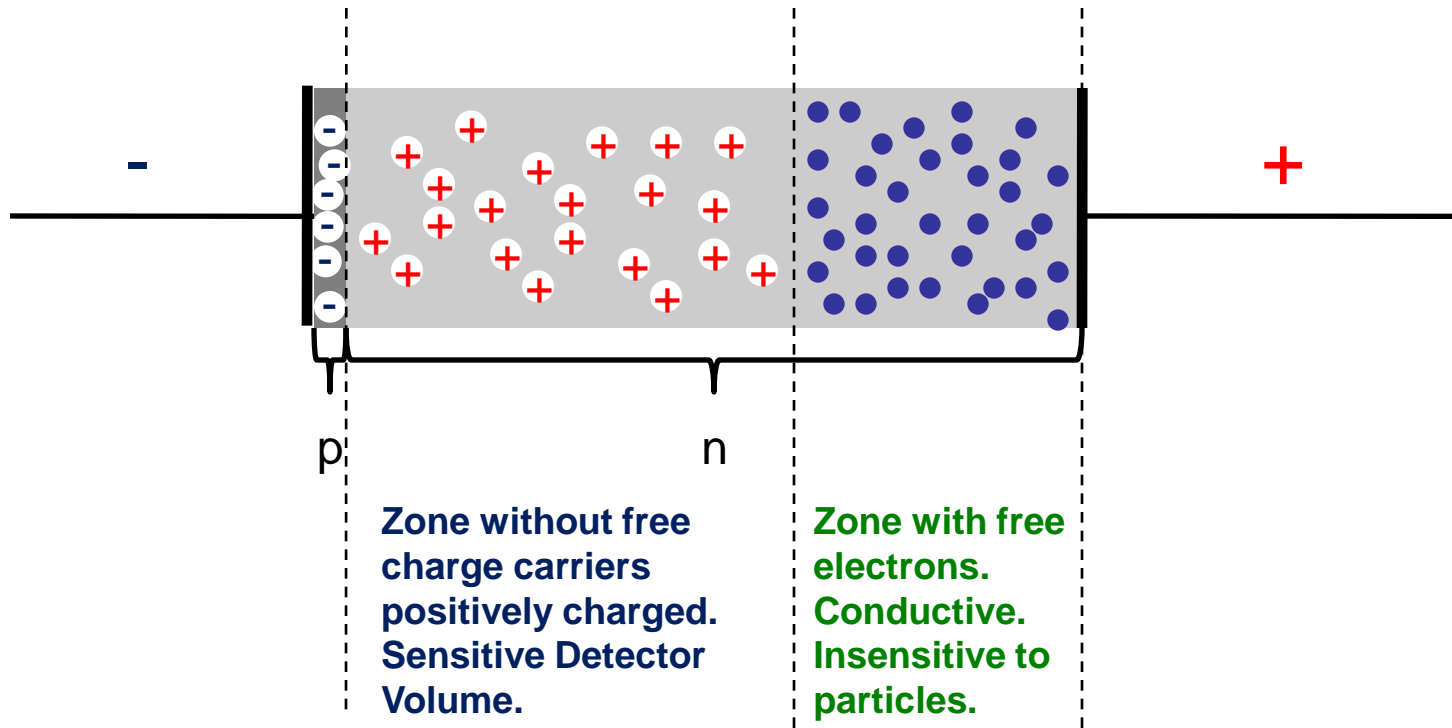

Fully-Depleted Silicon Detector

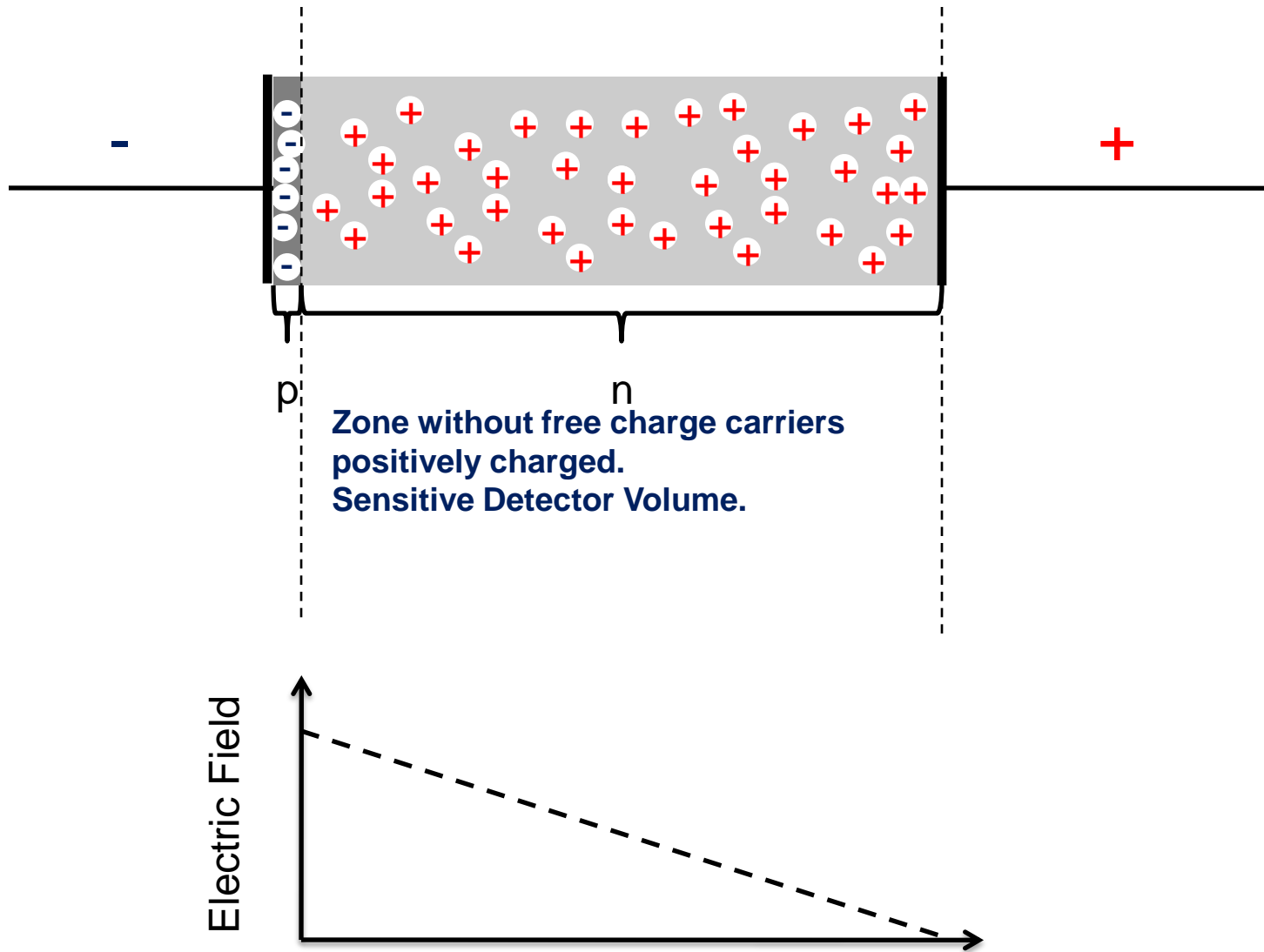

Over-Depleted Silicon Detector

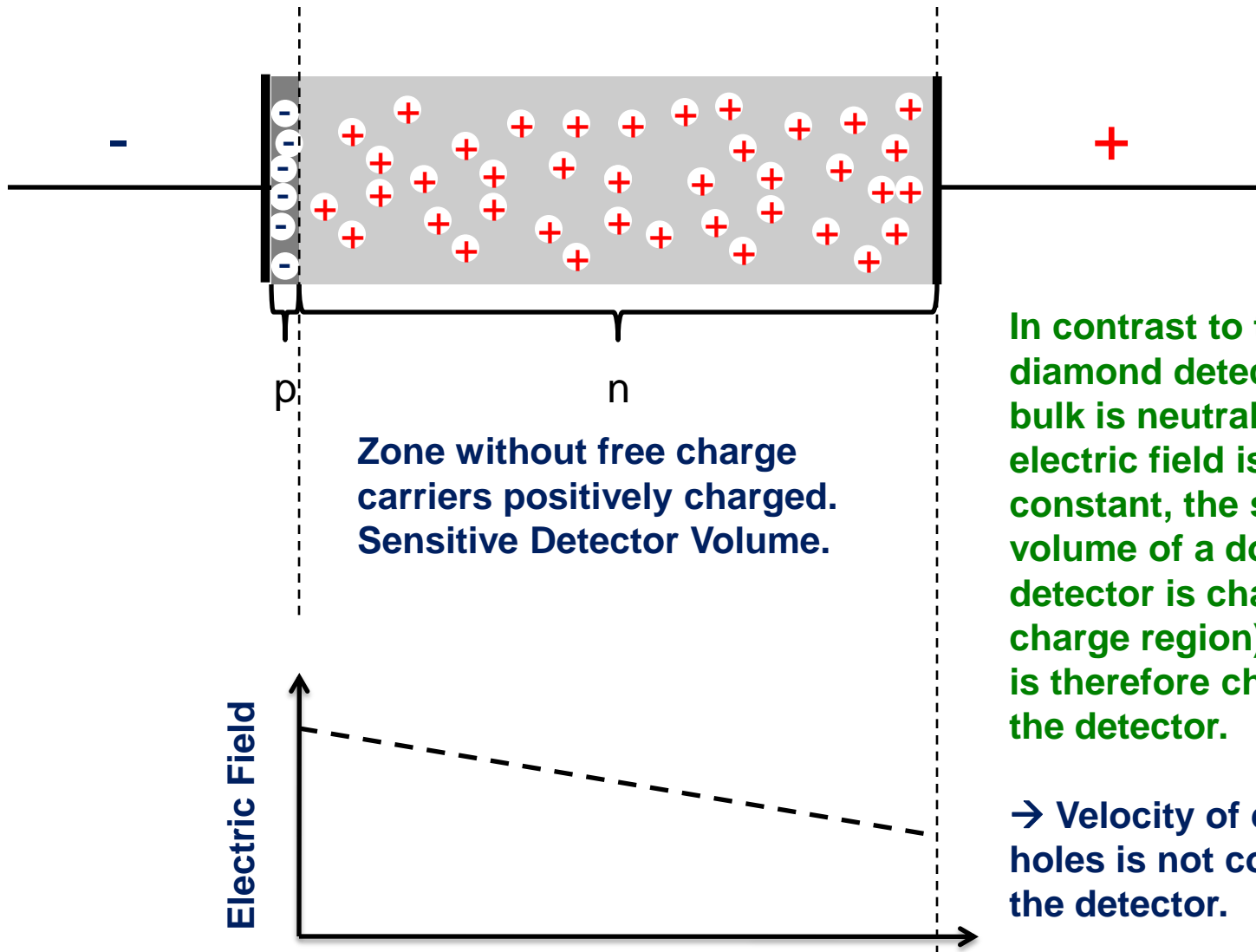

In contrast to the (un-doped) diamond detector where the bulk is neutral and the electric field is therefore constant, the sensitive volume of a doped silicon detector is charged (space charge region) and the field is therefore changing along the detector.

→ Velocity of electrons and holes is not constant along the detector.

Silicon Detector

Fully depleted zone

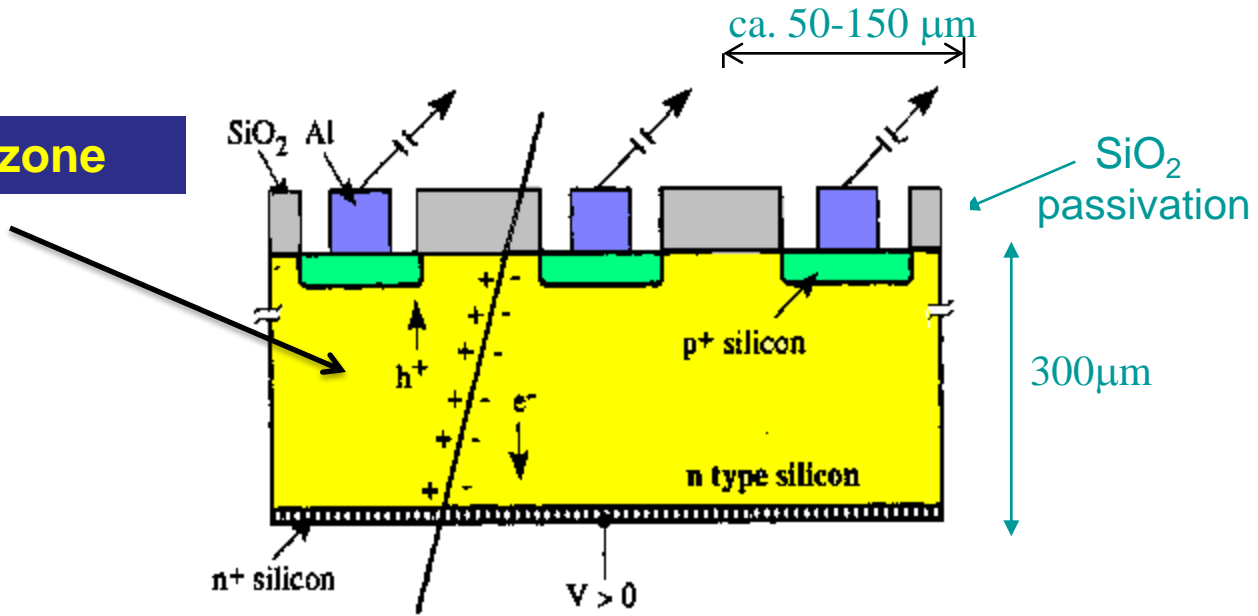

$N(e-h) = 11\ 000/100\mu\text{m}$

Position Resolution down to $\sim 5\mu\text{m}$!

Silicon Detector

Every electrode is connected to an amplifier →
Highly integrated readout electronics.

Two dimensional readout is possible.

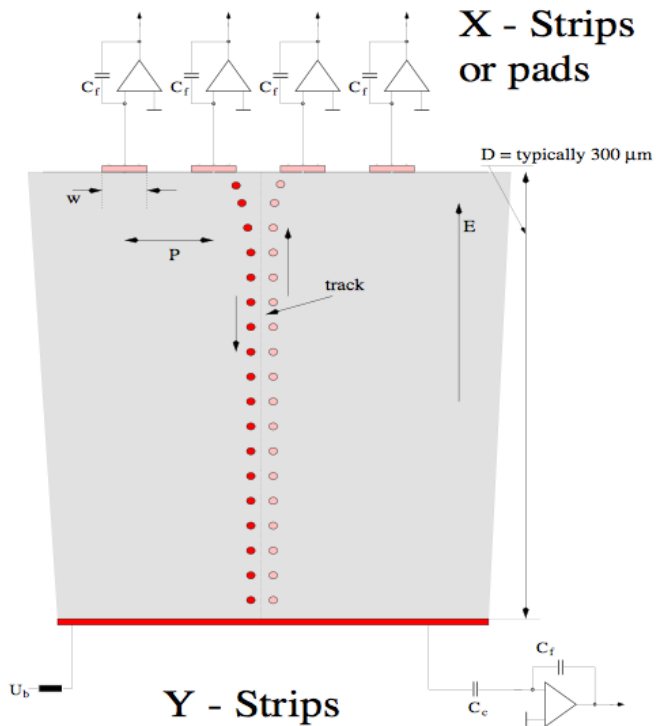

CMS Outer Barrel Module

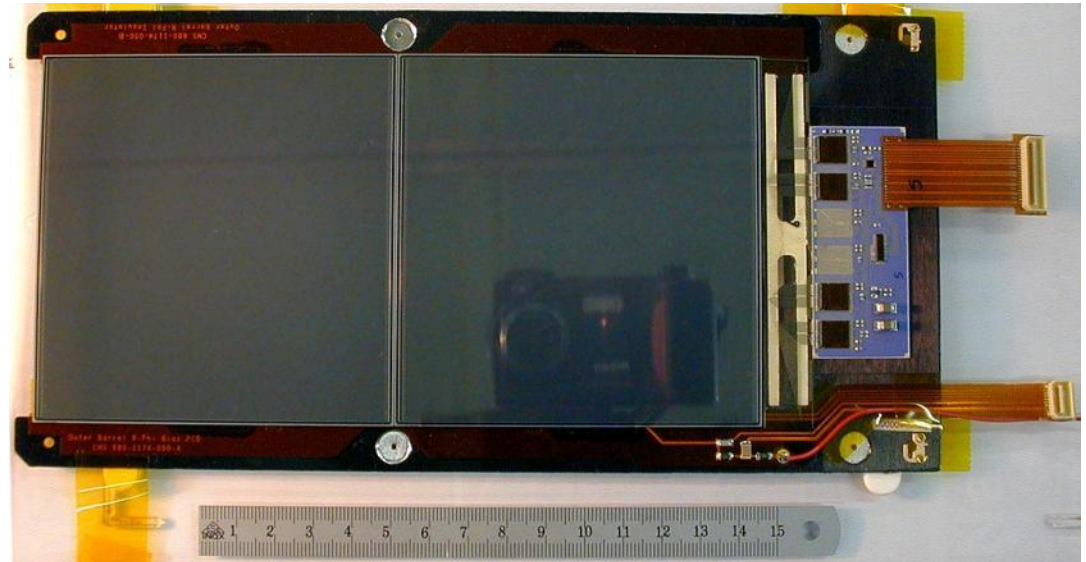

Large Silicon Systems

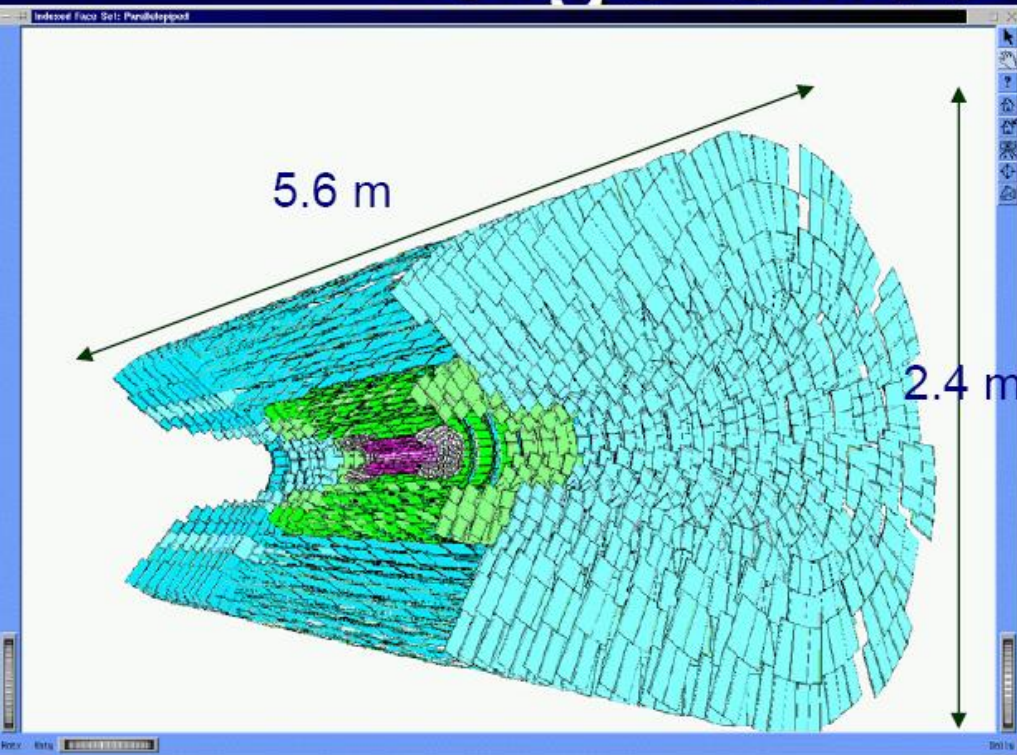

CMS tracker (~2007)

12000 modules

~ 445 m² silicon area

~ 24,328 silicon wafers

~ 60 M readout channels

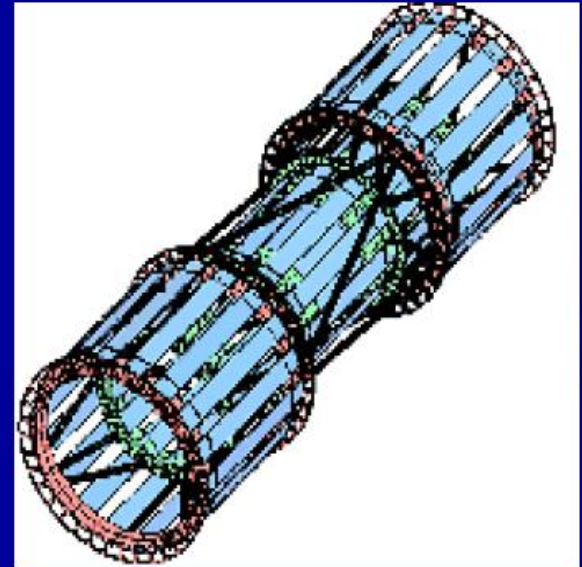

CDF SVX IIa (2001-)

~ 11m² silicon area

~ 750 000 readout channels

CMS Tracker

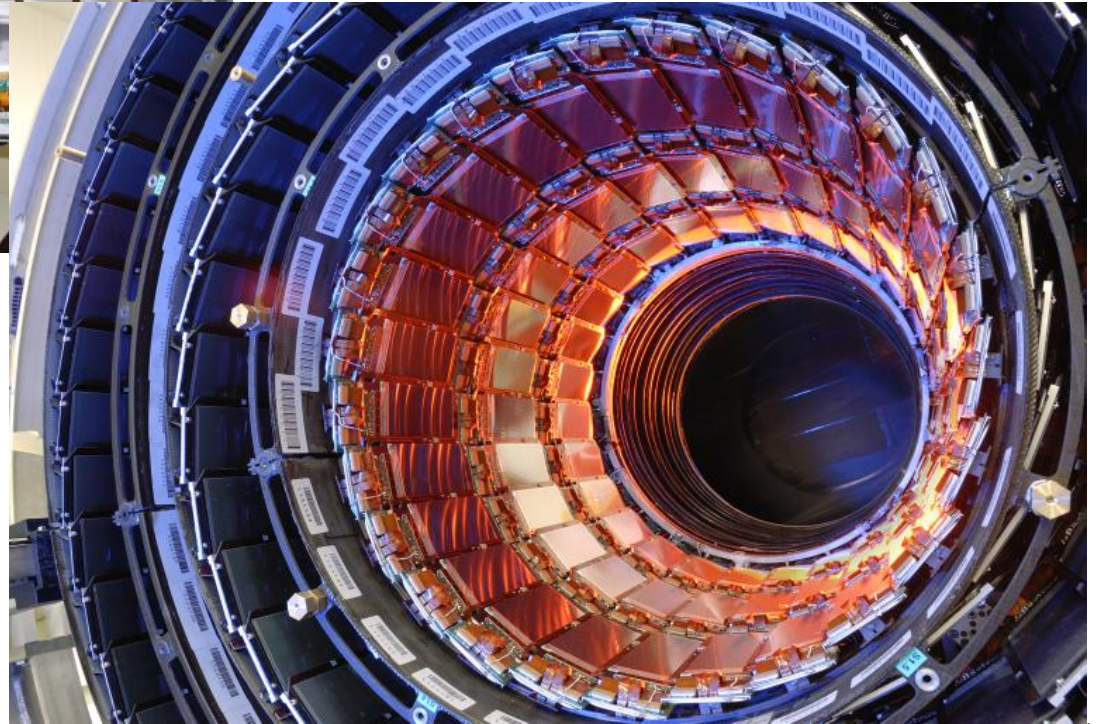

Silicon Drift Detector (like gas TPC !)

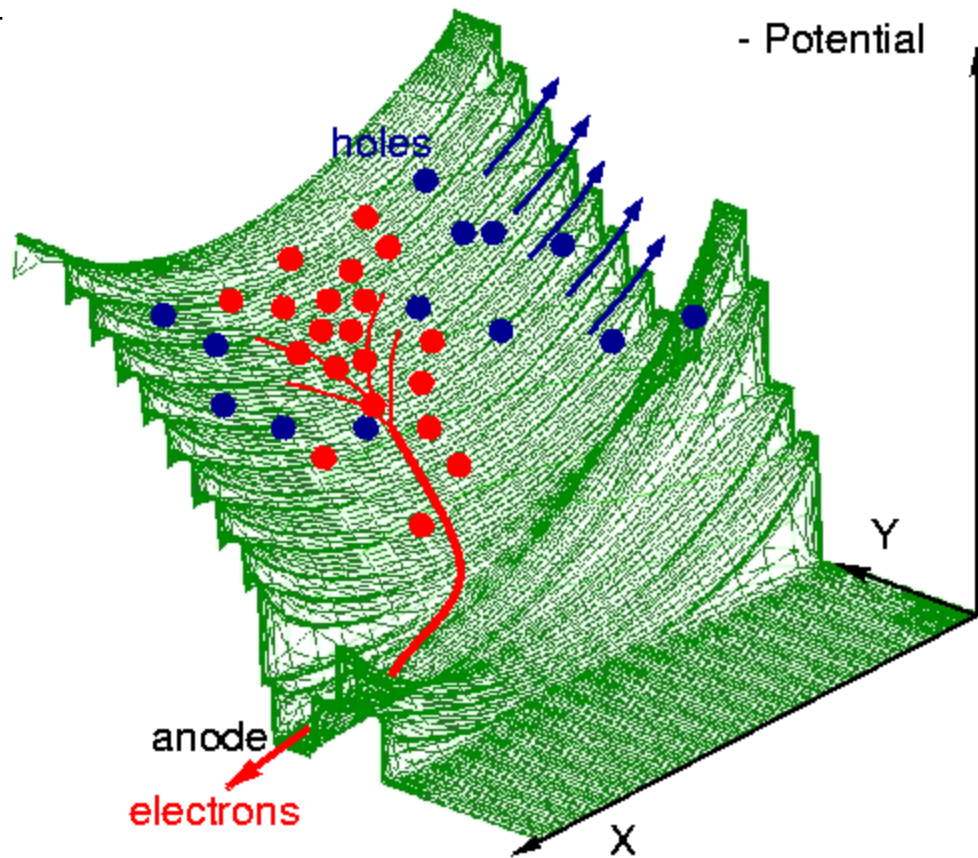
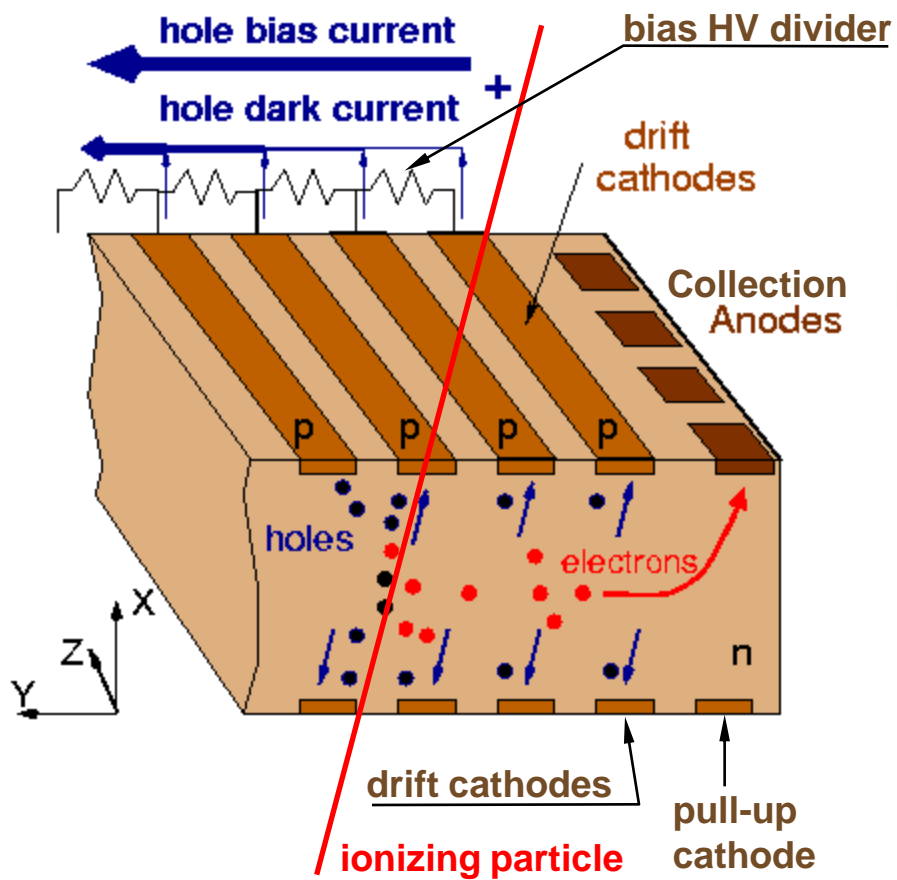

Silicon Drift Detector (like gas TPC !)

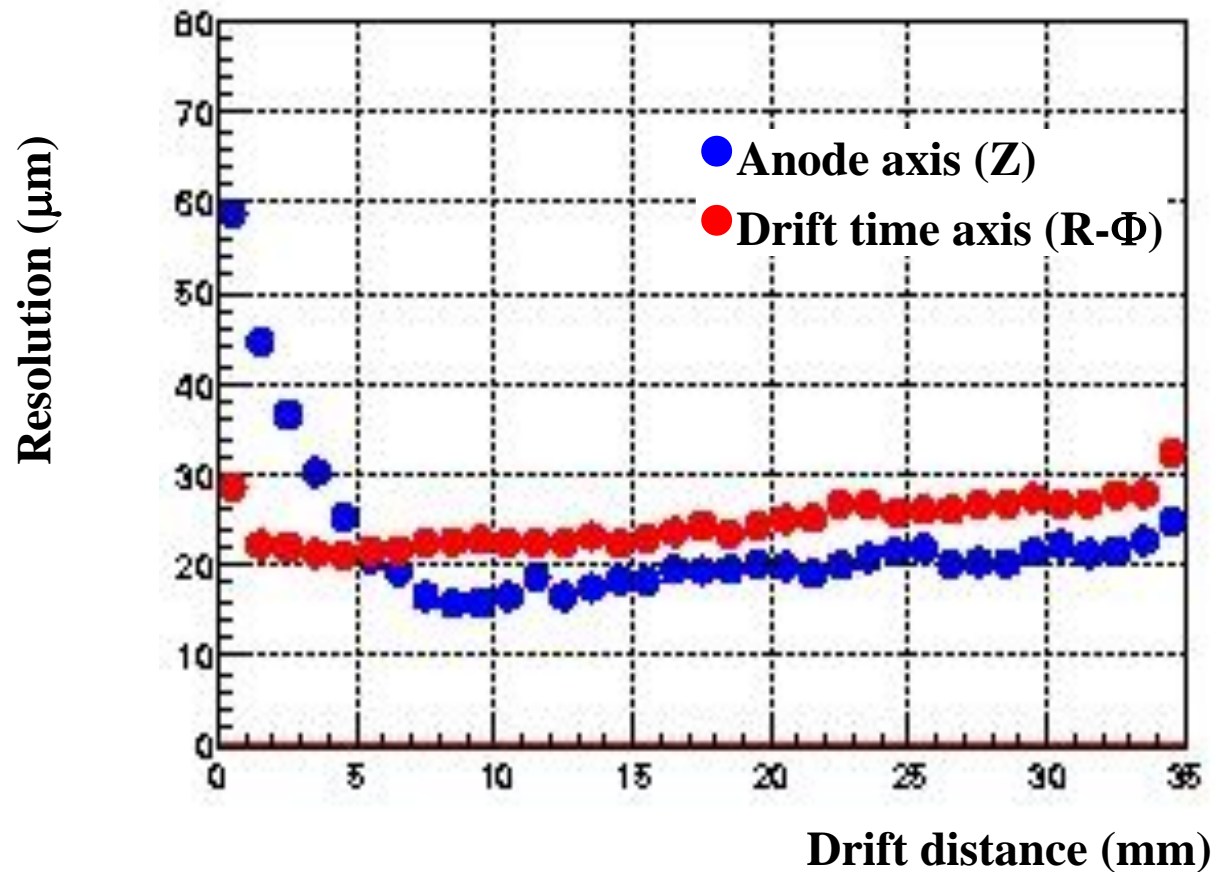

Pixel-Detectors

Problem:

2-dimensional readout of strip detectors results in 'Ghost Tracks' at high particle multiplicities i.e. many particles at the same time.

Solution:

Si detectors with 2 dimensional 'chessboard' readout. Typical size 50 x 200 μm .

Problem:

Coupling of readout electronics to the detector

Solution:

Bump bonding

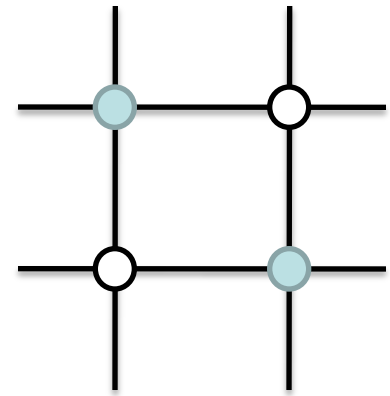

Bump Bonding of each Pixel Sensor to the Readout Electronics

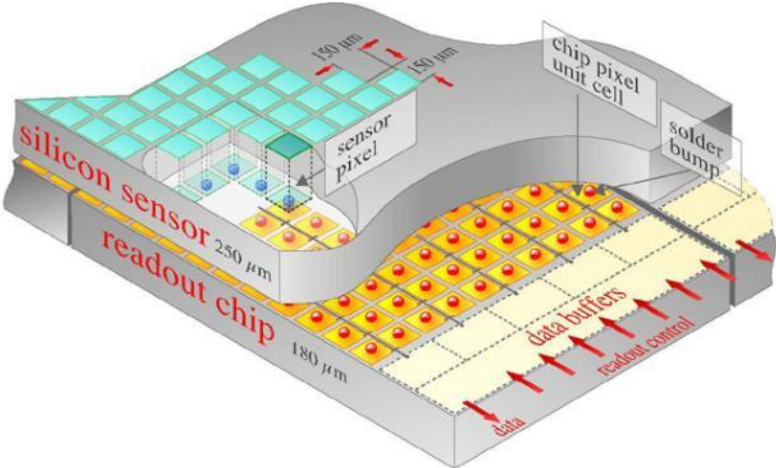

ATLAS: 1.4×10^8 pixels

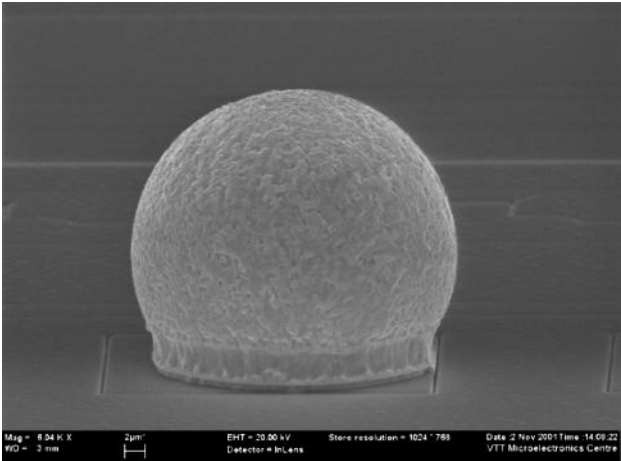
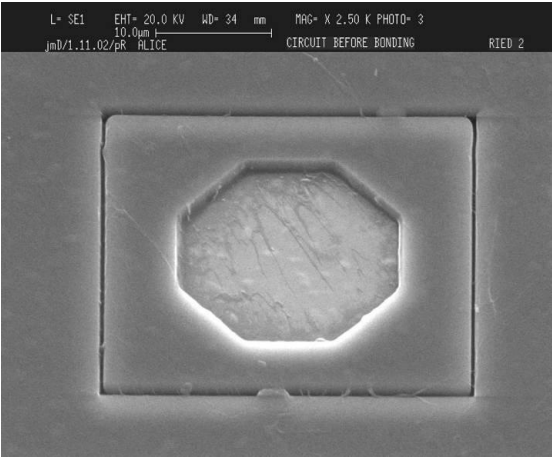

Radiation Effects 'Aging'

Increase in leakage current

Increase in depletion voltage

Decrease in charge collection efficiency due to under-depletion and charge trapping.

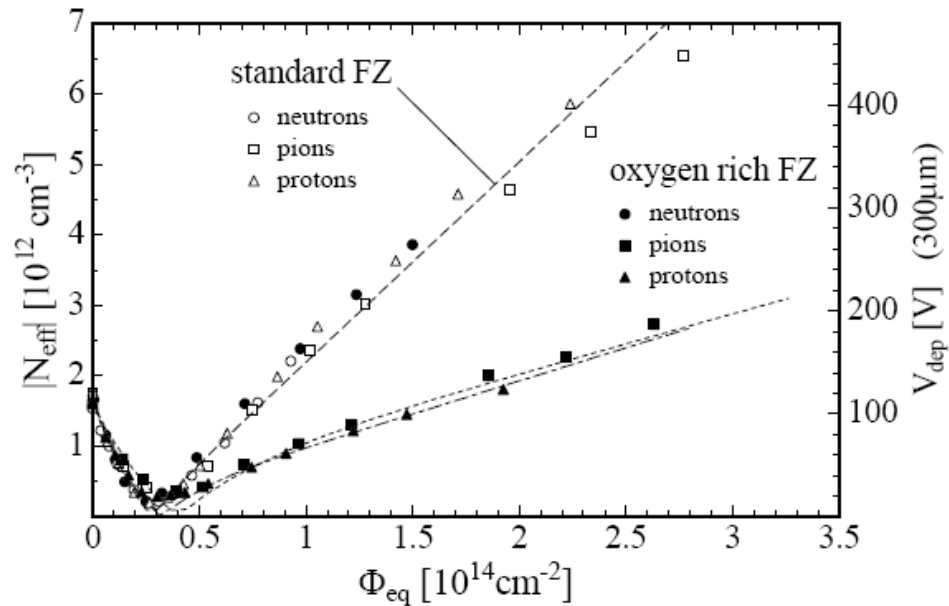
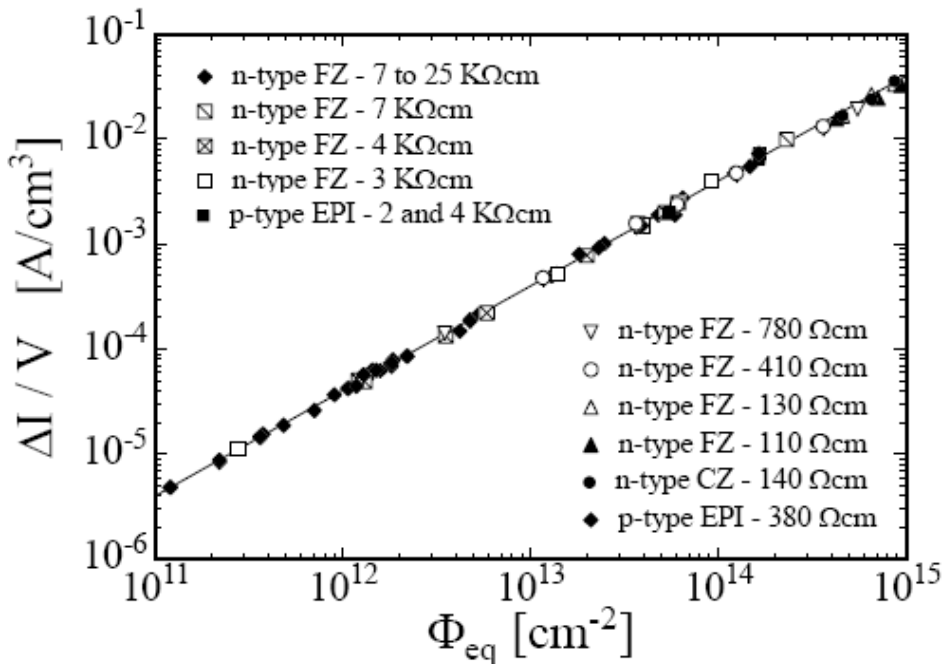

Obvious Goal: Monolithic Solid State Detectors

→ Sensor and Readout Electronics as integral unit

| | |
|------------------------------------|--|
| | <p>Hybrid Active Pixel: Chip bump bonded to sensor</p> <p>RD: make it thinner (LHC sensors 2% X_0/layer), improve space point resolution with interleaved pixels</p> |
| | <p>CCD: charge collected in thin layer and transferred through silicon</p> <p>RD: readout speed, radiation hardness, material support</p> |
| | <p>CMOS sensors (MAPS, FAPS): standard CMOS wafer integrates all functions.</p> <p>RD: fast readout, non-standard technologies</p> |
| <p>Poster by Deptuch on Mimoso</p> | <p>DEPFET, CMOS on SOI (talk by Kucewiz) :</p> <p>Fully depleted sensor with integrated preamp</p> <p>RD: pixel size, power, thinning, speed</p> |
| | |

Large variety of monolithic pixel Detectors are explored, Currently mostly adapted to low collision rates of Linear Colliders.

Summary on Solid State Detectors

Solid state detectors provide very high precision tracking in particle physics experiments (down to 5 μ m) for vertex measurement but also for momentum spectroscopy over large areas (CMS).

Technology is improving rapidly due to rapid Silicon development for electronics industry.

Typical numbers where detectors start to strongly degrade are 10^{14} - 10^{15} hadron/cm².

Diamond, engineered Silicon and novel geometries provide higher radiation resistance.

Clearly, monolithic solid state detectors are the ultimate goal. Current developments along these lines are useful for low rate applications.

Calorimetry

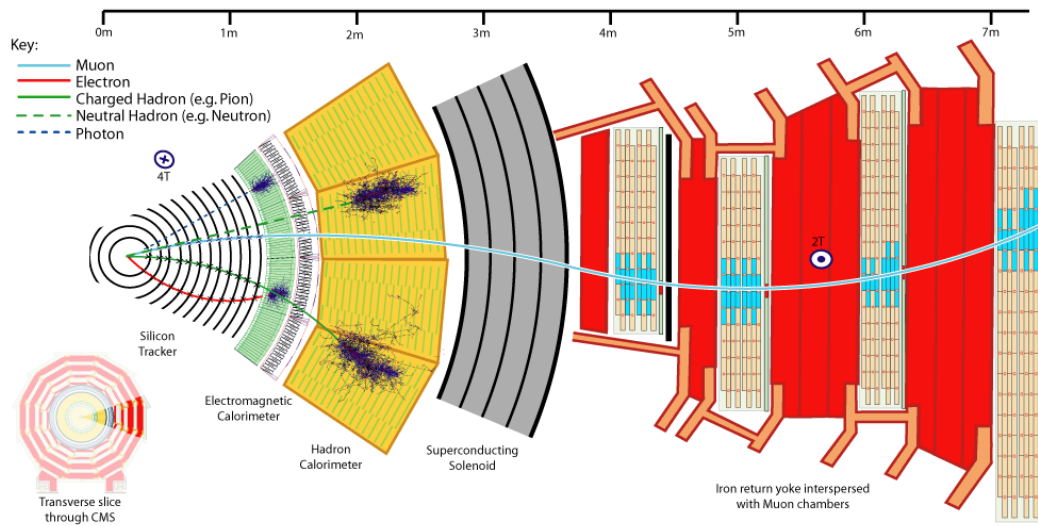
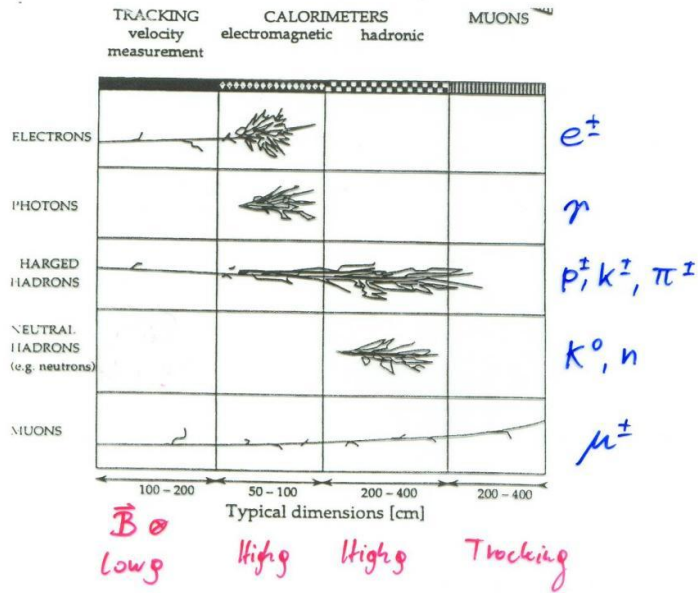

Bremsstrahlung

A charged particle of mass M and charge $q=Z_1e$ is deflected by a nucleus of charge Ze (which is partially 'shielded' by the electrons). During this deflection the charge is 'accelerated' and it therefore radiates \rightarrow Bremsstrahlung.

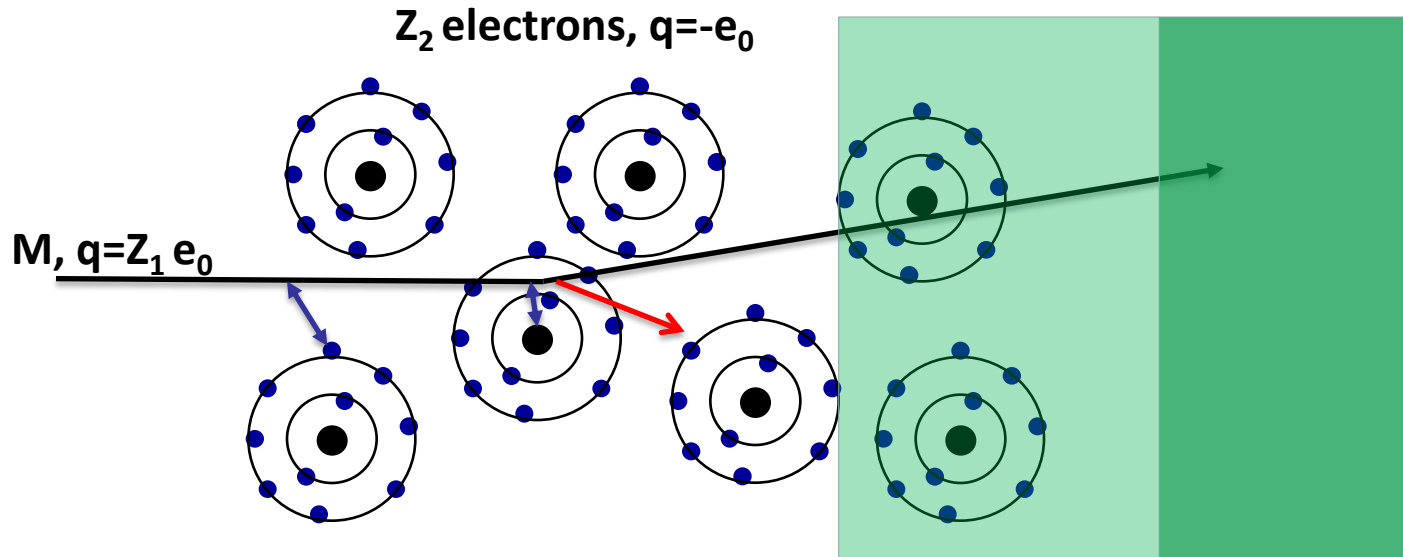

7/16/2010

Bremsstrahlung + Pair Production \rightarrow EM Shower

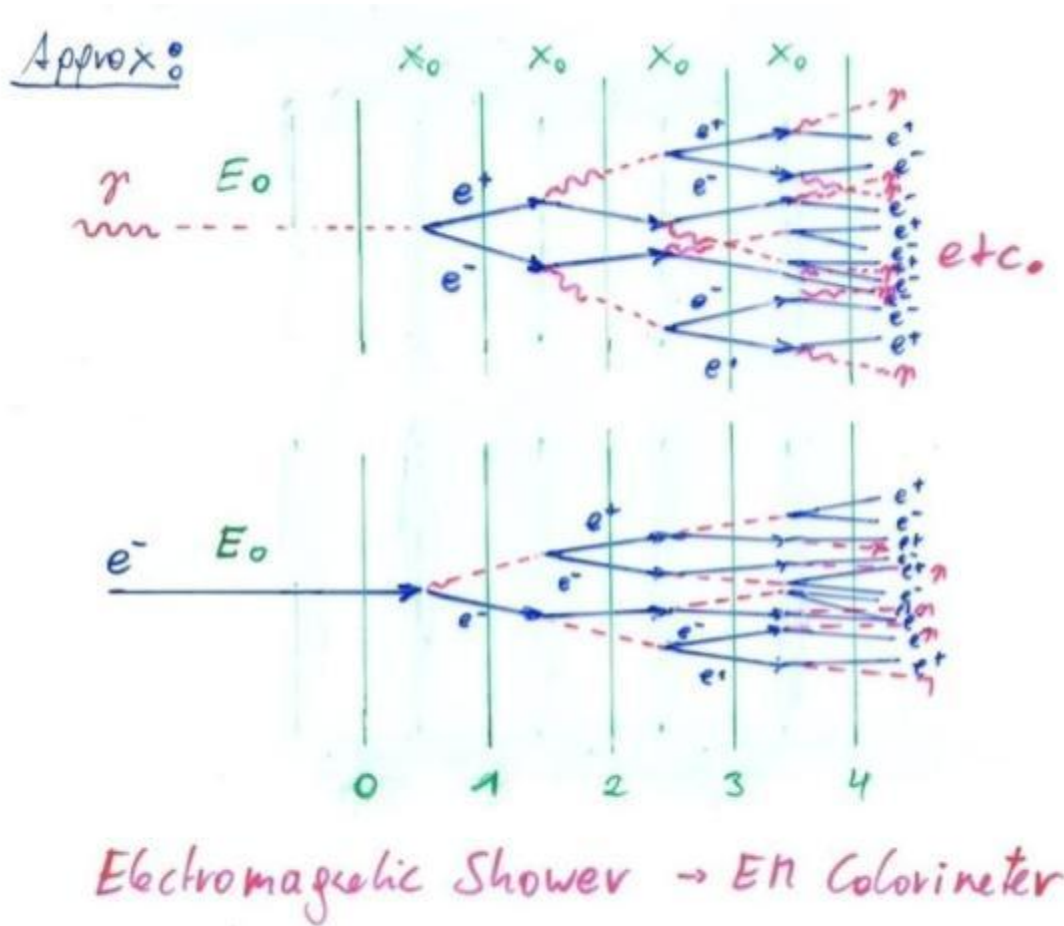

Electro-Magnetic Shower of High Energy Electrons and Photons

$N(n) = 2^n$ Number of particles (e^\pm, γ) after $n X_0$

$E(n) = \frac{E_0}{2^n}$ Average Energy of particles after $n X_0$

Shower stops if $E(n) = E_{critical}$

$\Rightarrow n_{max} = \frac{1}{\ln 2} \ln \frac{E_0}{E_c}$ \rightarrow Shower length rises with $\ln E_0$

Number of e^\pm track segments (of length X_0) after $n X_0$:

$$N_{tr}(n) = 2^n$$

Total e^\pm track length (after $n_{max} X_0$)

$$L = \sum_{n=0}^{n_{max}} 2^n X_0 = (2 \frac{E_0}{E_c} - 1) X_0 \sim 2 \frac{E_0}{E_c} X_0 = c_1 \cdot E_0$$

Total (charge) track length is proportional to the Energy of the Particle.

\rightarrow Calorimeter Principle

Calorimetry: Energy Measurement by total Absorption of Particles

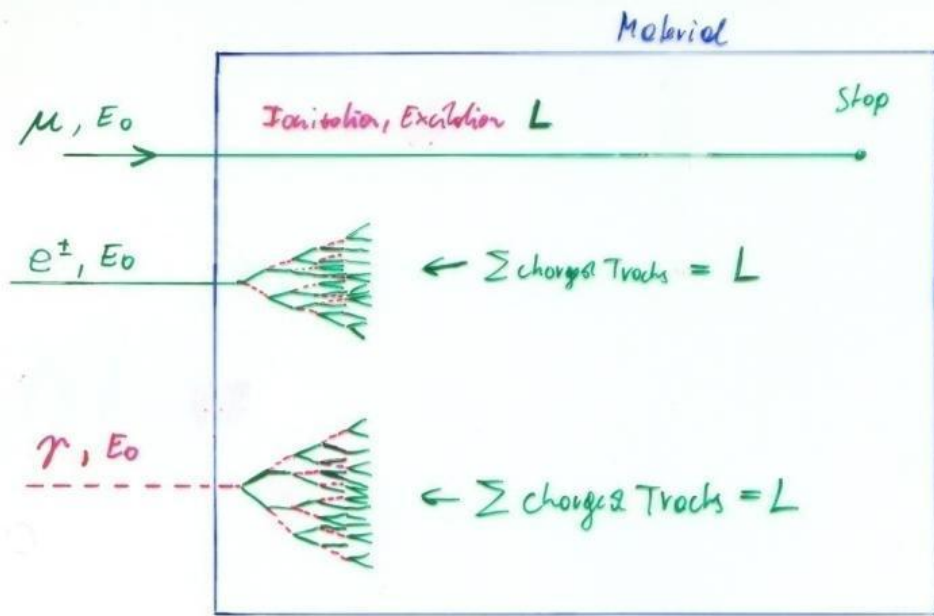

??

If N is the total Number of e^+, I^+ pairs or photons, or $N = c_1 E_0$:

$$\Delta N = \sqrt{N} \quad (\text{Poisson Statistics})$$

$$\frac{\Delta E}{E} = \frac{\Delta N}{N} = \frac{1}{\sqrt{N}} = \frac{a}{\sqrt{E}} \rightarrow \text{Resolution}$$

Only Electrons and High Energy Photons show EM cascades at current GeV-TeV level Energies.

Strongly interacting particles like Pions, Kaons, produce hadronic showers in a similar fashion to the EM cascade
→ Hadronic calorimetry

Momentum Spectrometer: $\Delta p/p \propto p$

Calorimeter: $\Delta E/E \propto 1/\sqrt{E}$

Energy measurement improves with higher particle energies – LHC !

The e^\pm in the Calorimeter ionize and excite the Material

Ionization: e^-, I^+ pairs in the Material

Excitation: Photons in the Material

Measuring the total Number of e^-, I^+ pairs or the total Number of Photons gives the particle Energy.

Calorimetry: Energy Measurement by total Absorption of Particles

The measurement is destructive. The particle can not be subject to further study.

Energy Measurement by

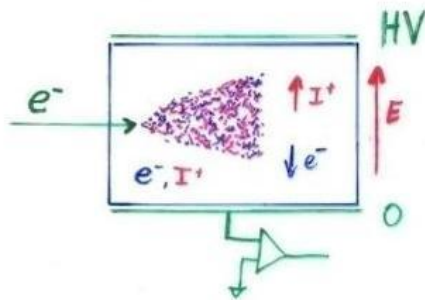

Collecting the produced Charge

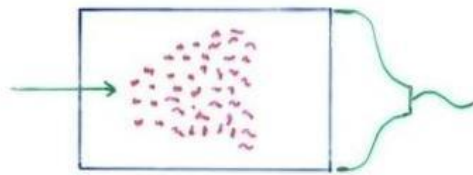

Measuring the Photons produced by the collision of the e^\pm with the Atom Electrons of the Material.

Total Amount of e^-, I^+ pairs or Photons is proportional to the total track length is proportional to the particle Energy.

**Liquid Nobel Gases
(Nobel Liquids)**

**Scintillating Crystals,
Plastic Scintillators**

Calorimetry

Calorimeters can be classified into:

Electromagnetic Calorimeters,
to measure electrons and photons through their EM interactions.

Hadron Calorimeters,
Used to measure hadrons through their strong and EM interactions.

The construction can be classified into:

Homogeneous Calorimeters,
that are built of only one type of material that performs both tasks, energy degradation and signal generation.

Sampling Calorimeters,
that consist of alternating layers of an absorber, a dense material used to degrade the energy of the incident particle, and an active medium that provides the detectable signal.

C.W. Fabjan and F. Gianotti, Rev. Mod. Phys., Vol. 75, NO. 4, October 2003

Calorimetry

Calorimeters are attractive in our field for various reasons:

In contrast with magnet spectrometers, in which the momentum resolution deteriorates linearly with the particle momentum, on most cases the calorimeter energy resolution improves as $1/\sqrt{E}$, where E is the energy of the incident particle. Therefore calorimeters are very well suited for high-energy physics experiments.

In contrast to magnet spectrometers, calorimeters are sensitive to all types of particles, charged and neutral. They can even provide indirect detection of neutrinos and their energy through a measurement of the event missing energy.

Calorimeters are commonly used for trigger purposes since they can provide since they can provide fast signals that are easy to process and interpret.

They are space and therefore cost effective. Because the shower length increases only logarithmically with energy, the detector thickness needs to increase only logarithmically with the energy of the particles. In contrast for a fixed momentum resolution, the bending power BL^2 of a magnetic spectrometer must increase linearly with the particle momentum.

C.W. Fabjan and F. Gianotti, Rev. Mod. Phys., Vol. 75, NO. 4, October 2003

EM Calorimetry

Approximate longitudinal shower development

$N(n) = 2^n$ Number of particles (e^\pm, γ) after $n X_0$

$E(n) = \frac{E_0}{2^n}$ Average Energy of particles after $n X_0$

Shower stops if $E(n) = E_{critical}$

$\Rightarrow n_{max} = \frac{1}{\ln 2} \ln \frac{E_0}{E_c} \rightarrow$ Shower length rises with $\ln E_0$

Radiation Length X_0 and Moliere Radius are two key parameters for choice of calorimeter materials

Approximate transverse shower development

The transverse Shower Dimension is mainly related to the Multiple scattering of the low Energy Electrons.

$$\theta_0 \sim \frac{21 [\text{MeV}]}{\beta p [\frac{\text{MeV}}{c}]} z_1 \cdot \sqrt{\frac{x}{X_0}}$$

Electrons E_c , $E \sim p \cdot c$

$$\theta_0 \sim \frac{21 [\text{MeV}]}{\beta E_c [\text{MeV}]} \cdot z_1 \cdot \sqrt{\frac{x}{X_0}} \quad z_1 = 1, \beta = 1$$

$$E_c \sim \frac{610}{Z+1.24} \text{ MeV} \sim \frac{610}{Z} \text{ MeV}$$

$$\theta_0 = 0.0344 \cdot Z \cdot \sqrt{\frac{x}{X_0}}$$

Moliere Radius $g_m =$ Local Shower Radius after $1 X_0$:

$$\underline{g_m \approx 0.0344 \cdot Z \cdot X_0}$$

95% of Energy are in a Cylinder of $2 g_m$ Radius.

Crystals for Homogeneous EM Calorimetry

In crystals the light emission is related to the crystal structure of the material. Incident charged particles create electron-hole pairs and photons are emitted when electrons return to the valence band.

The incident electron or photon is completely absorbed and the produced amount of light, which is reflected through the transparent crystal, is measured by photomultipliers or solid state photon detectors.

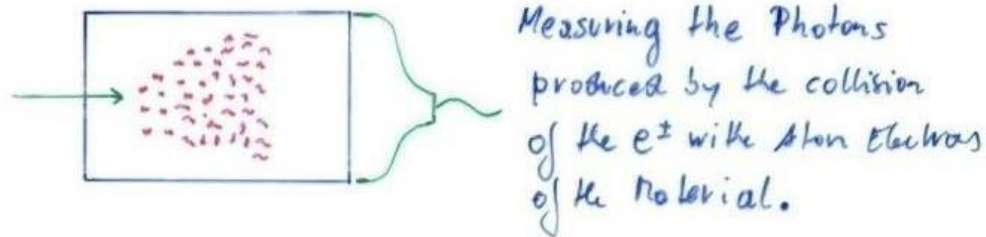

Crystals for Homogeneous EM Calorimetry

| | NaI(Tl) | CsI(Tl) | CsI | BGO | PbWO ₄ |
|--|-----------------|-----------------|-----------------|-----------------|-------------------|
| Density (g/cm ³) | 3.67 | 4.53 | 4.53 | 7.13 | 8.28 |
| X_0 (cm) | 2.59 | 1.85 | 1.85 | 1.12 | 0.89 |
| R_M (cm) | 4.5 | 3.8 | 3.8 | 2.4 | 2.2 |
| Decay time (ns) | 250 | 1000 | 10 | 300 | 5 |
| slow component | | | 36 | | 15 |
| Emission peak (nm) | 410 | 565 | 305 | 410 | 440 |
| slow component | | | 480 | | |
| Light yield γ /MeV | 4×10^4 | 5×10^4 | 4×10^4 | 8×10^3 | 1.5×10^2 |
| Photoelectron yield (relative to NaI) | 1 | 0.4 | 0.1 | 0.15 | 0.01 |
| Rad. hardness (Gy) | 1 | 10 | 10^3 | 1 | 10^5 |

Barbar@PEPII,
10ms
interaction
rate, good light
yield, good S/N

KTeV@Tev
atron,
High rate,
Good
resolution

L3@LEP,
25us
bunch
crossing,
Low
radiation
dose

CMS@LHC,
25ns bunch
crossing,
high
radiation
dose

Crystals for Homogeneous EM Calorimetry

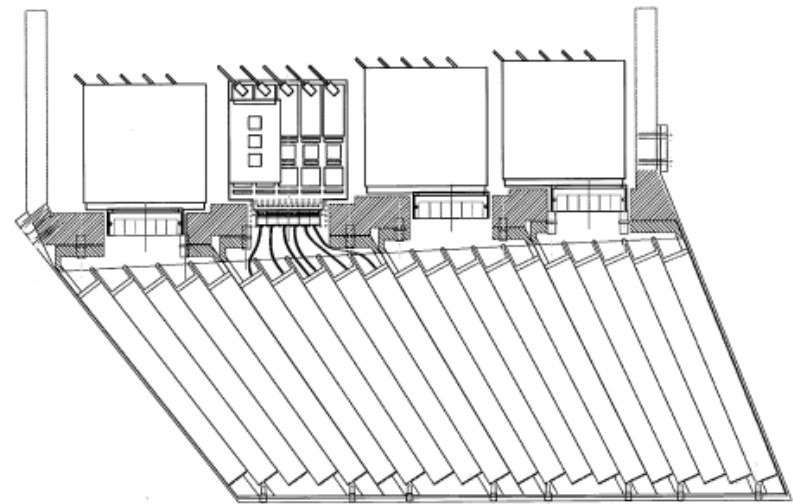
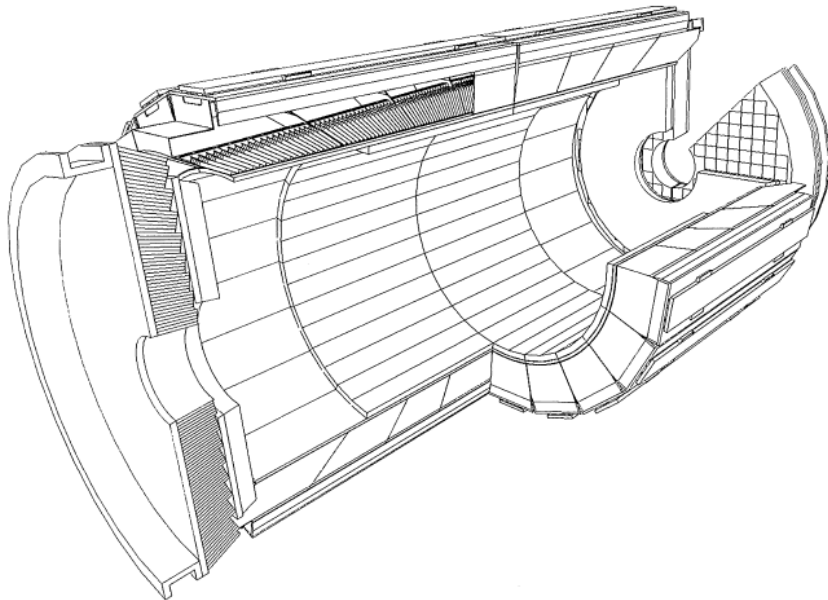
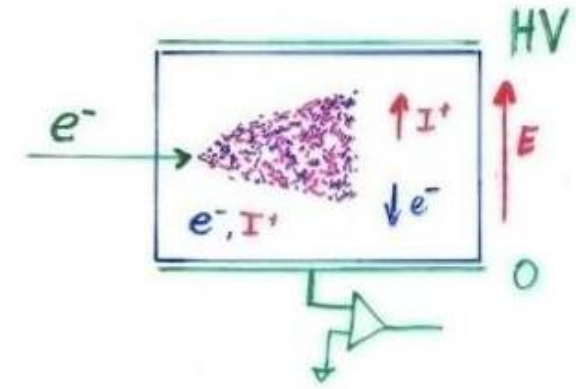

Fig. 2. Longitudinal drawing of module 2, showing the structure and the front-end electronics layout.

Noble Liquids for Homogeneous EM Calorimetry

| | Ar | Kr | Xe |
|--|------|------|------|
| Z | 18 | 36 | 58 |
| A | 40 | 84 | 131 |
| X_0 (cm) | 14 | 4.7 | 2.8 |
| R_M (cm) | 7.2 | 4.7 | 4.2 |
| Density (g/cm ³) | 1.4 | 2.5 | 3.0 |
| Ionization energy (eV/pair) | 23.3 | 20.5 | 15.6 |
| Critical energy ϵ (MeV) | 41.7 | 21.5 | 14.5 |
| Drift velocity at saturation (mm/ μ s) | 10 | 5 | 3 |



When a charge particle traverses these materials, about half the lost energy is converted into ionization and half into scintillation.

The best energy resolution would obviously be obtained by collecting both the charge and light signal. This is however rarely done because of the technical difficulties to extract light and charge in the same instrument.

Krypton is preferred in homogeneous detectors due to small radiation length and therefore compact detectors. Liquid Argon is frequently used due to low cost and high purity in sampling calorimeters (see later).

Noble Liquids for Homogeneous EM Calorimetry

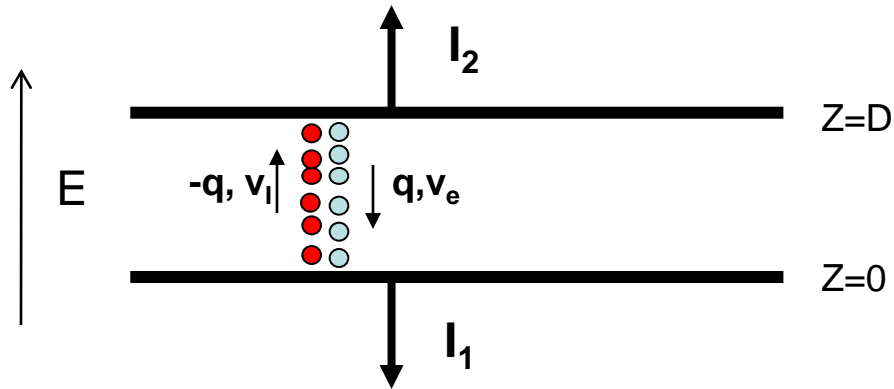

E.g. Liquid Argon, 5mm/ μs at 1kV/cm, 5mm gap \rightarrow 1 μs for all electrons to reach the electrode.

The ion velocity is 10^3 to 10^5 times smaller \rightarrow doesn't contribute to the signal for electronics of μs integration time.

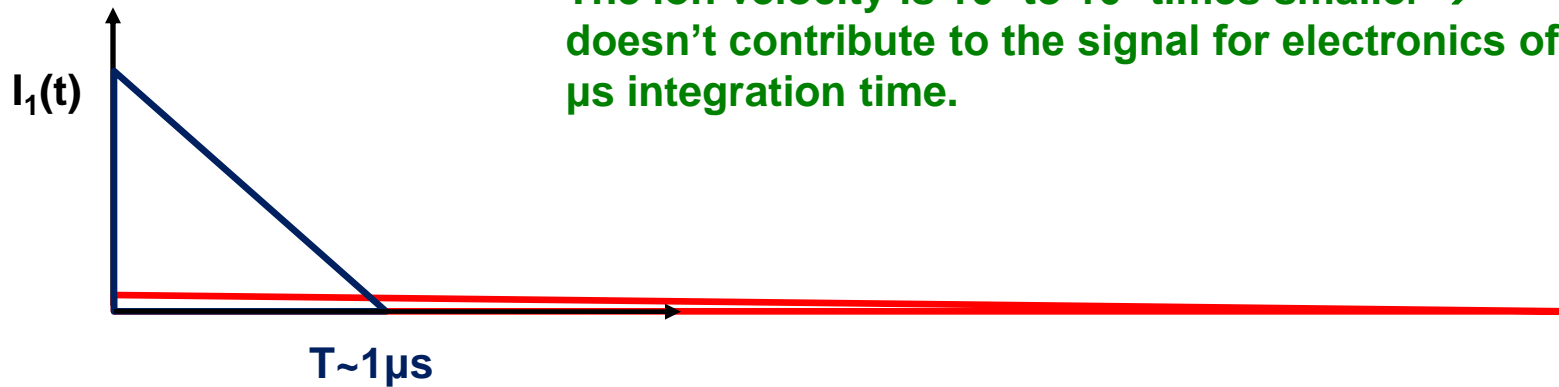

Homogeneous EM Calorimeters, Examples

NA48 Liquid Krypton
 2cmx2cm cells
 $X_0 = 4.7\text{cm}$
 125cm length ($27X_0$)
 $\rho = 5.5\text{cm}$

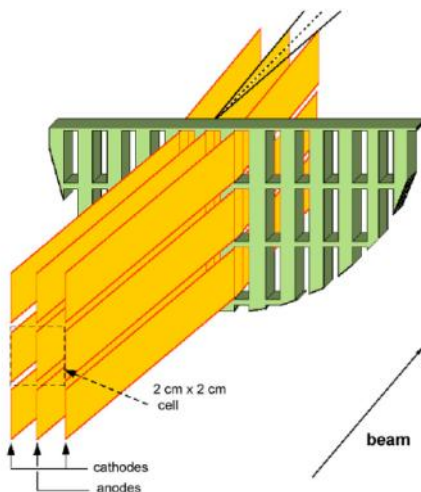

KTeV CsI
 5cmx5cm and
 $X_0 = 1.85\text{cm}$
 2.5cmx2.5cm crystals
 50cm length ($27X_0$)
 $\rho = 3.5\text{cm}$

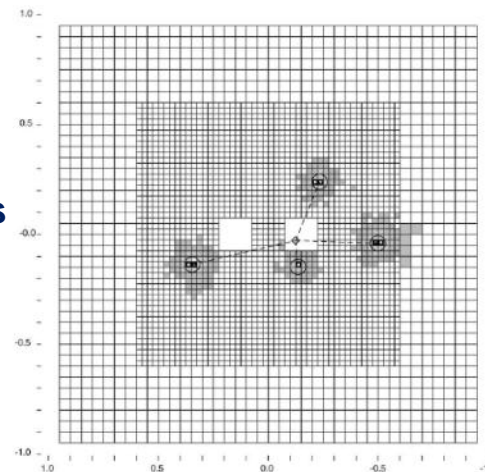
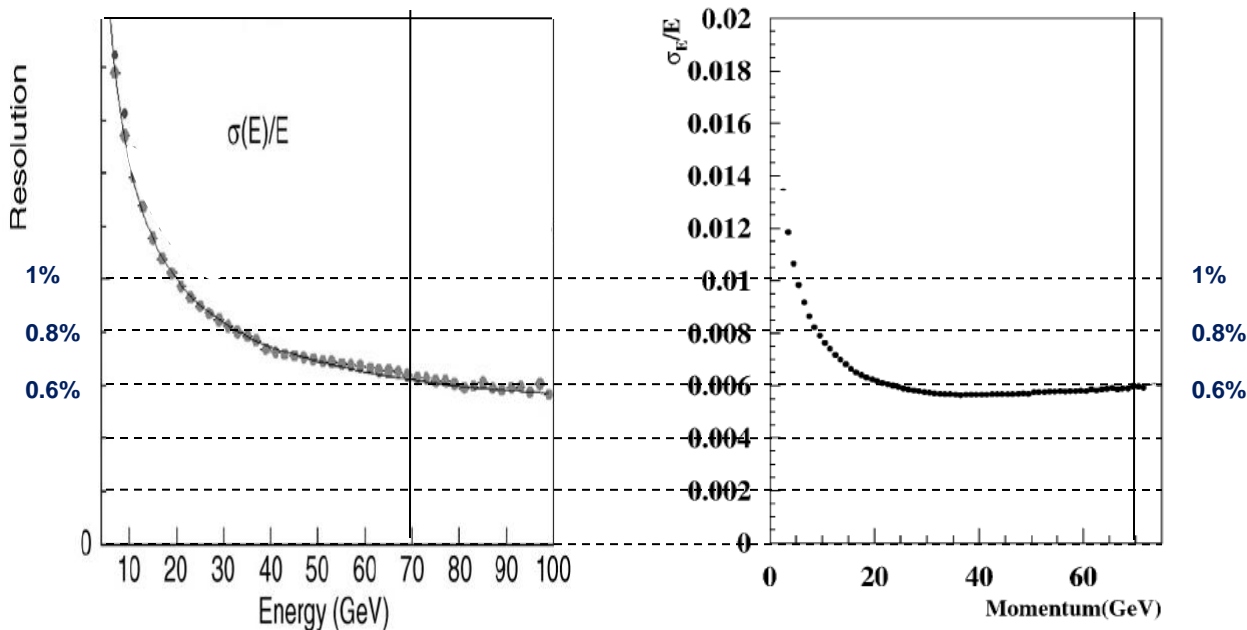

Fig. 1. Schematic of the KTeV CsI Calorimeter showing the cluster energy profiles due to four photons.

NA48 Experiment at CERN and KTeV Experiment at Fermilab, both built for measurement of direct CP violation. Homogenous calorimeters with Liquid Krypton (NA48) and CsI (KTeV). Excellent and very similar resolution.



Sampling Calorimeters

Alternation of "passive" absorber plates and "active" readout sections

Advantage:

- optimum choice of Absorber Material
- optimum choice of Signal Readout
- Compact and cheap Construction

"passive": Pb, Fe

"active": Scintillator (Signal \rightarrow Photons)
 Noble Liquid, e.g. Ar (Signal $\rightarrow e^-, I^+$)
 Wire Chambers (Signal $\rightarrow e^-, I^+$)

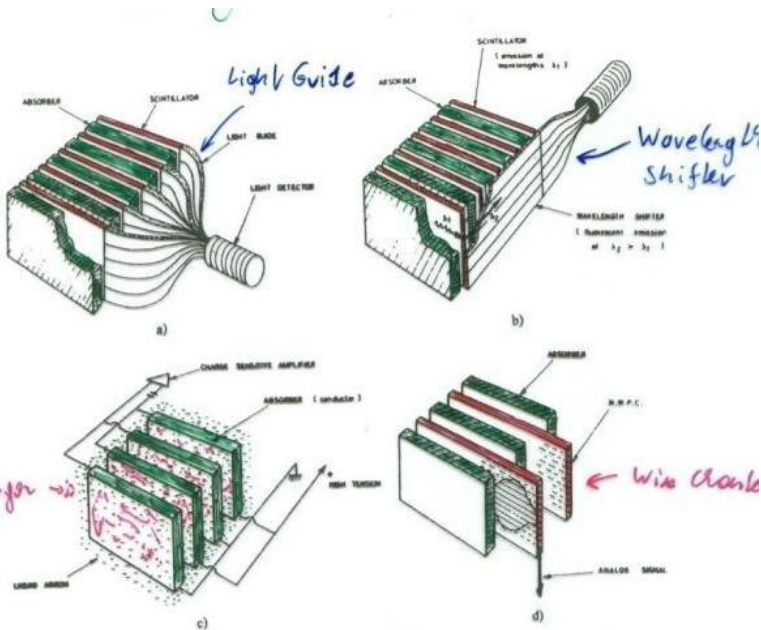

Energy resolution of sampling calorimeters is in general worse than that of homogeneous calorimeters, owing to the sampling fluctuations – the fluctuation of ratio of energy deposited in the active and passive material.

The resolution is typically in the range $5-20\%/\sqrt{E(\text{GeV})}$ for EM calorimeters. On the other hand they are relatively easy to segment longitudinally and laterally and therefore they usually offer better space resolution and particle identification than homogeneous calorimeters.

The active medium can be scintillators (organic), solid state detectors, gas detectors or liquids.

Sampling Fraction = Energy deposited in Active/Energy deposited in passive material.

Hadronic Calorimetry

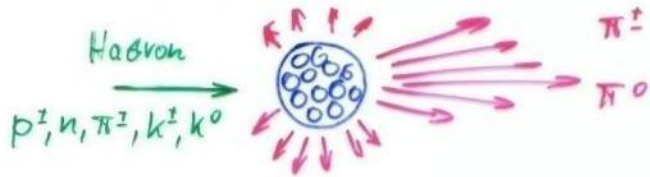

Strong Interaction

Approximate Energy Distribution

~50%

π^+, π^-, π^0

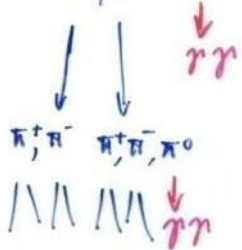

Hadron cascade

~20%

Nuclear Excitation

5-30 MeV

p, n, γ

~30%

Slow Nucleons

In Hadronic Cascades the longitudinal Shower is given by the Absorption Length λ_a $I \sim e^{-\frac{x}{\lambda_a}}$

In typical Detector Materials λ_a is much longer than X_0

$$\lambda \sim \frac{1}{9} \cdot 35 A^{\frac{1}{3}}$$

| | g | X_0 | λ |
|----|-------|---------|--------------|
| Fe | 7.87 | 1.76 cm | ~ 17 cm |
| Pb | 11.35 | 0.56 cm | ~ 17 cm |

Energy Resolution:

- A large Fraction of the Energy 'disappears' into
 - Binding Energy of emitted Nucleons
 - $\pi^0 \rightarrow \mu + \nu$ which are not absorbed
 - π^0 's Decaying into $\gamma\gamma$ start an EM Cascade ($\tau \sim 10^{-8}$ s)
- Energy Resolution is worse than for EM Calorimeters

Hadron Calorimeters are Large because λ is large

Hadron Calorimeters are large and heavy because the hadronic interaction length λ , the 'strong interaction equivalent' to the EM radiation length X_0 , is large (5-10 times larger than X_0)

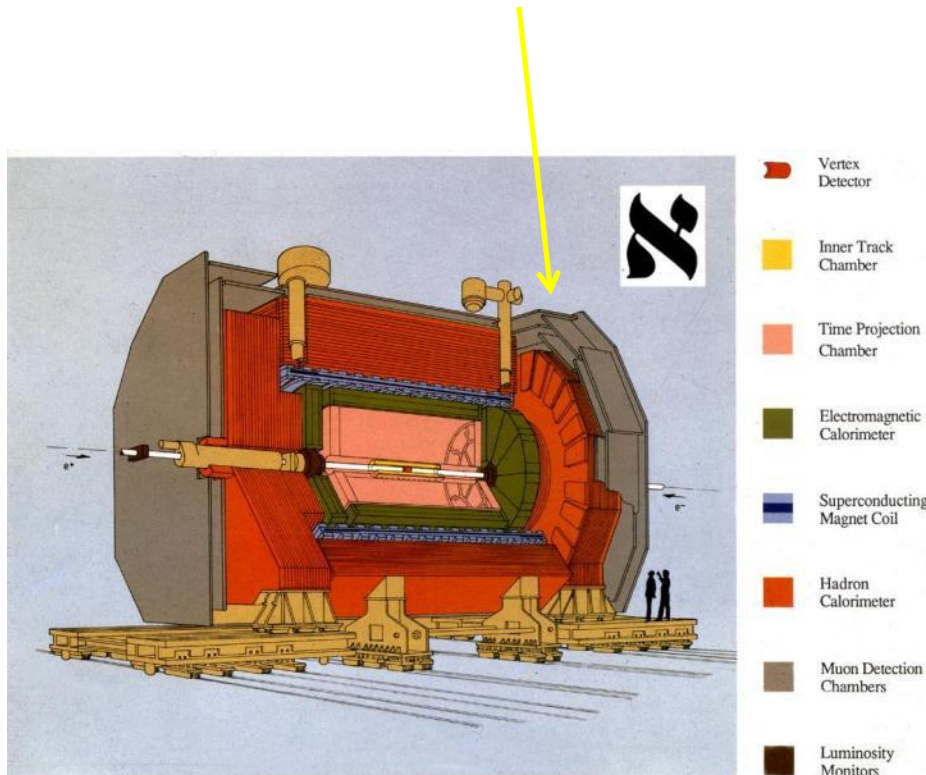
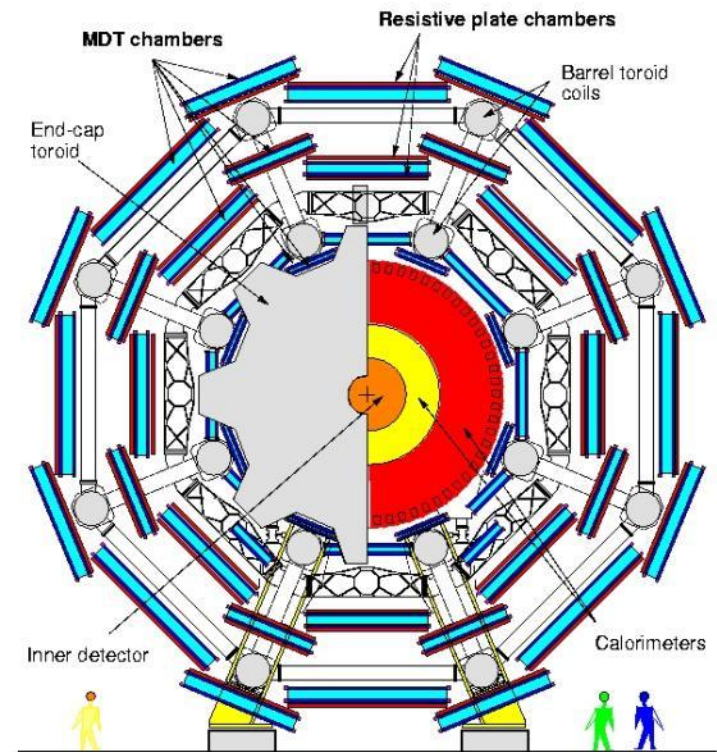

Fig. 1 - The ALEPH Detector

Because part of the energy is 'invisible' (nuclear excitation, slow nucleons), the resolution of hadron calorimeters is typically worse than in EM calorimeters $20-100\%/\sqrt{E(\text{GeV})}$.



Detector Systems

ALICE

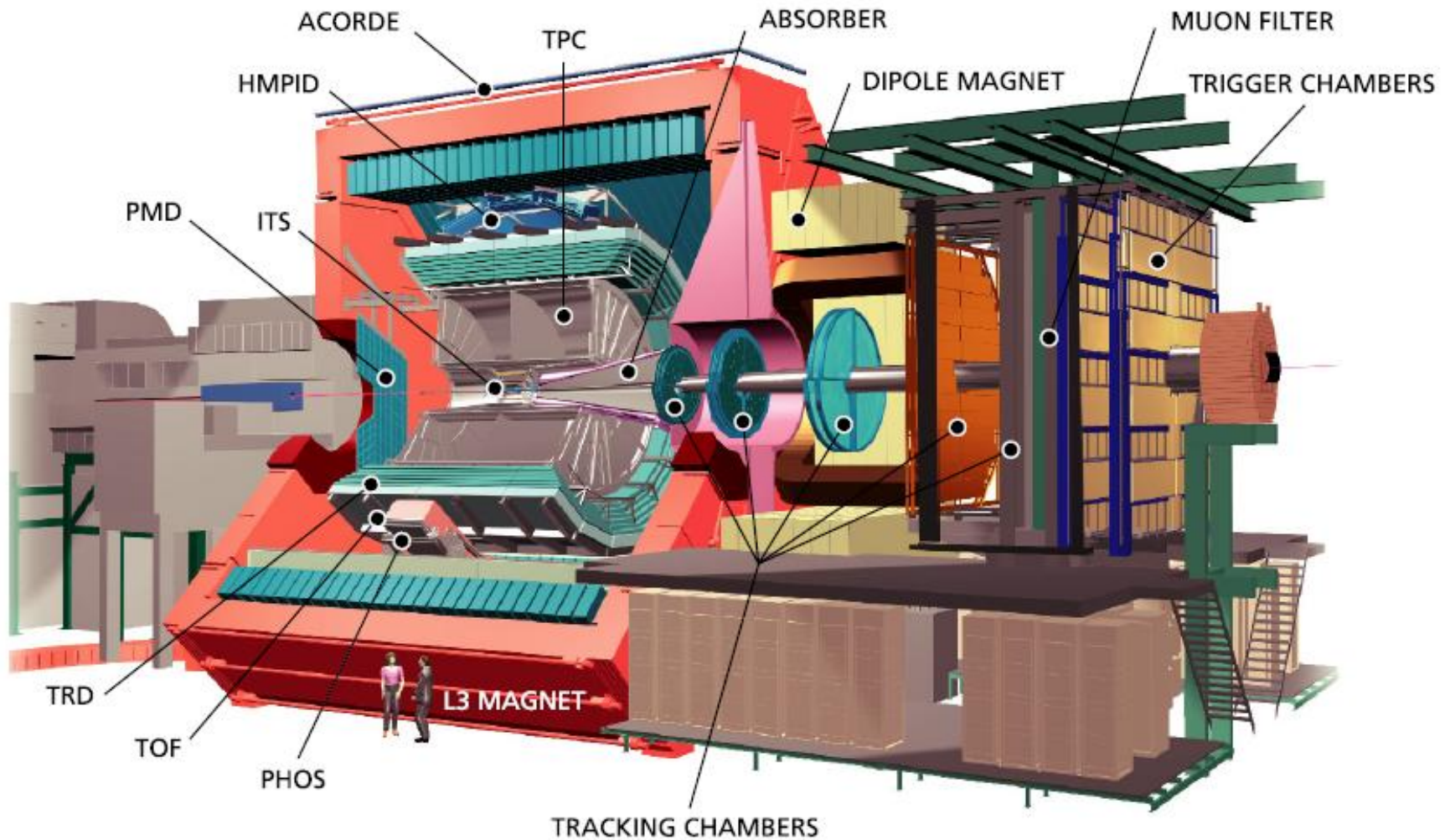

ALICE Particle ID

Alice uses ~ all known techniques!

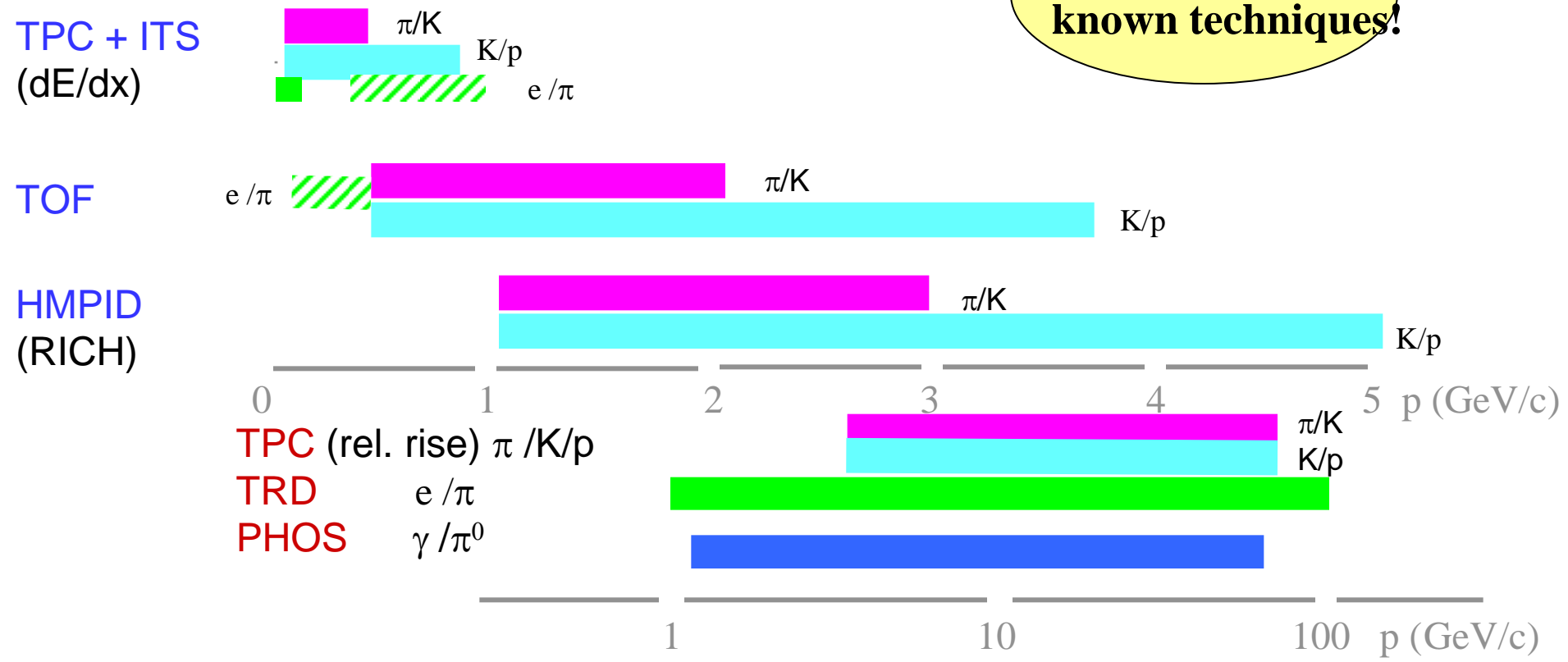

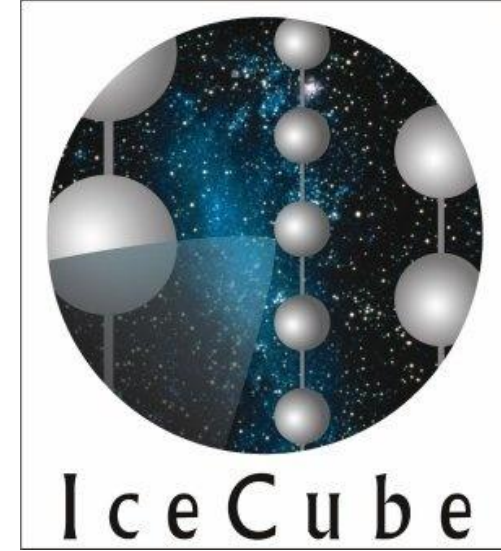
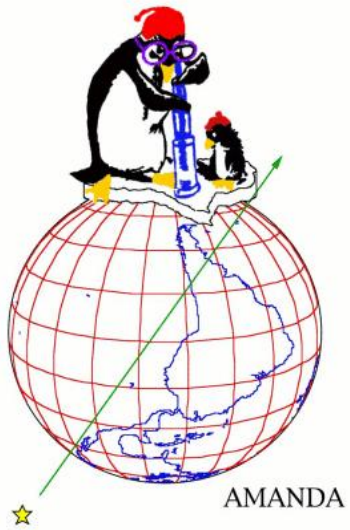

AMANDA

Antarctic **M**uon **A**nd **N**eutrino **D**etector **A**rray

AMANDA



South Pole



AMANDA

AMANDA-II

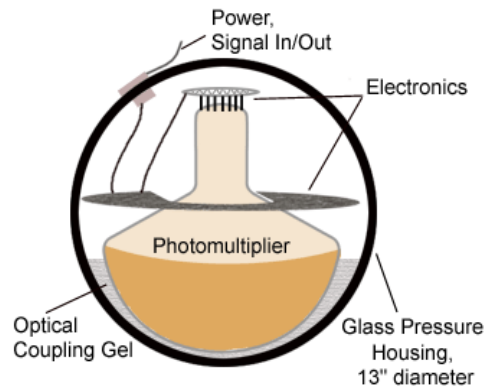
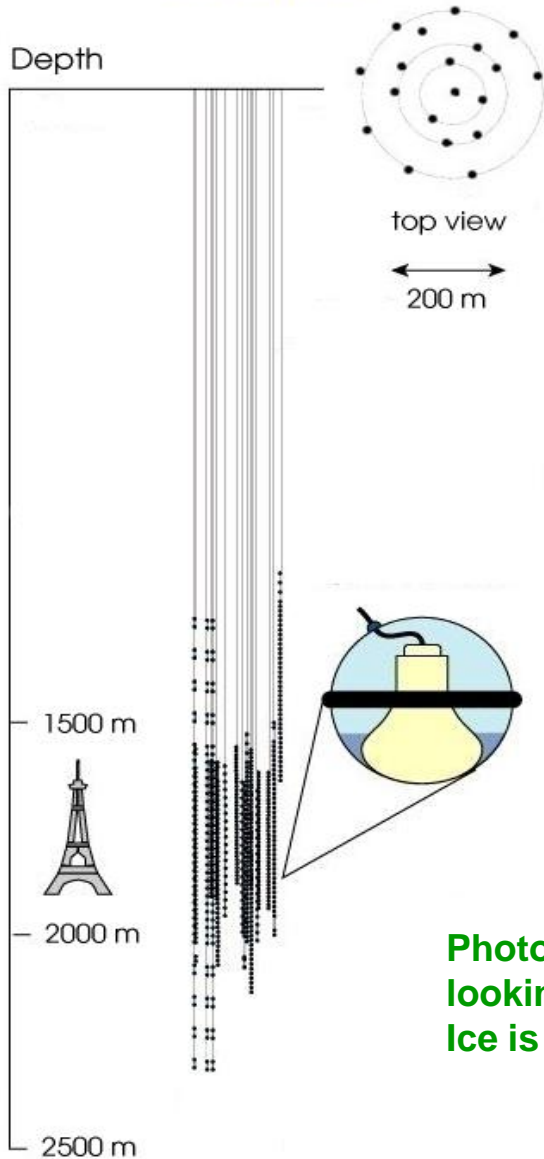

**Photomultipliers in the Ice,
looking downwards.
Ice is the detecting medium.**



AMANDA

Look for upwards going Muons from Neutrino Interactions.
Cherckov Light propagating through the ice.

→ Find neutrino point sources in the universe !

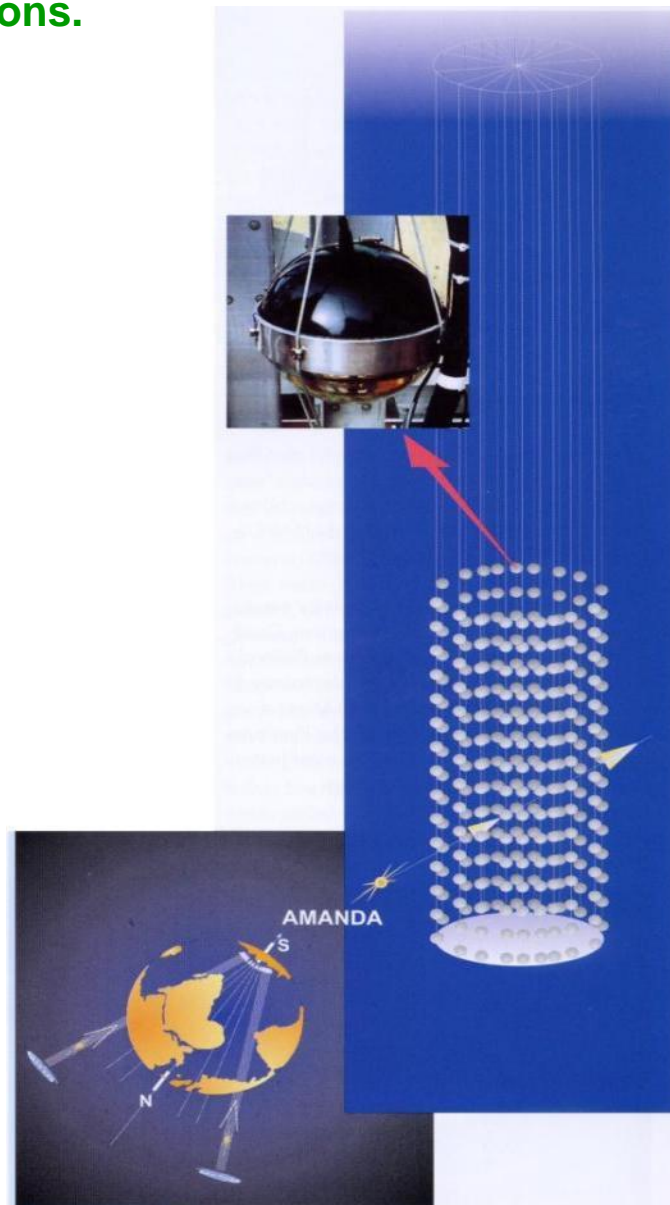
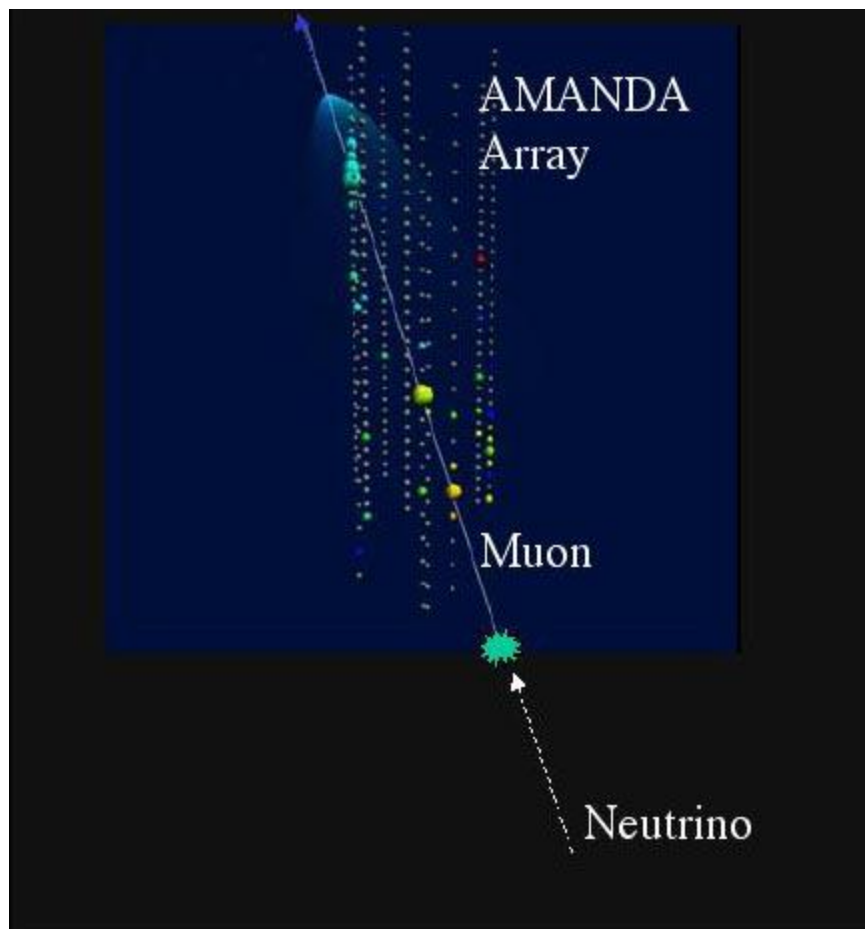

AMANDA

Event Display

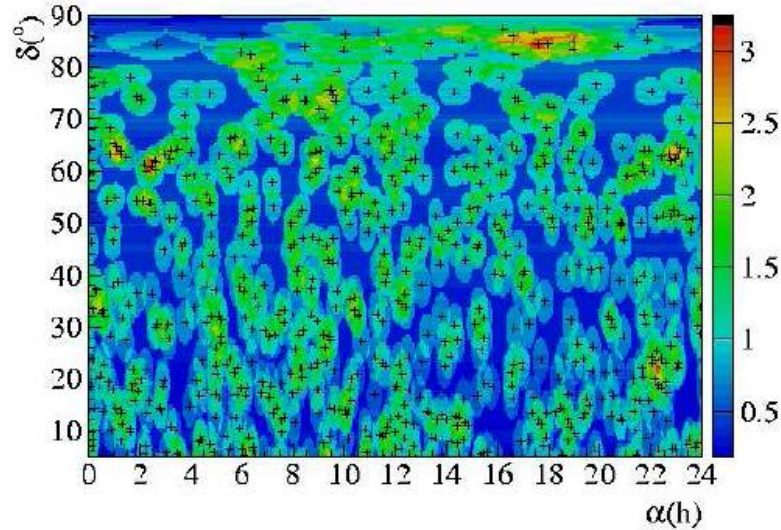
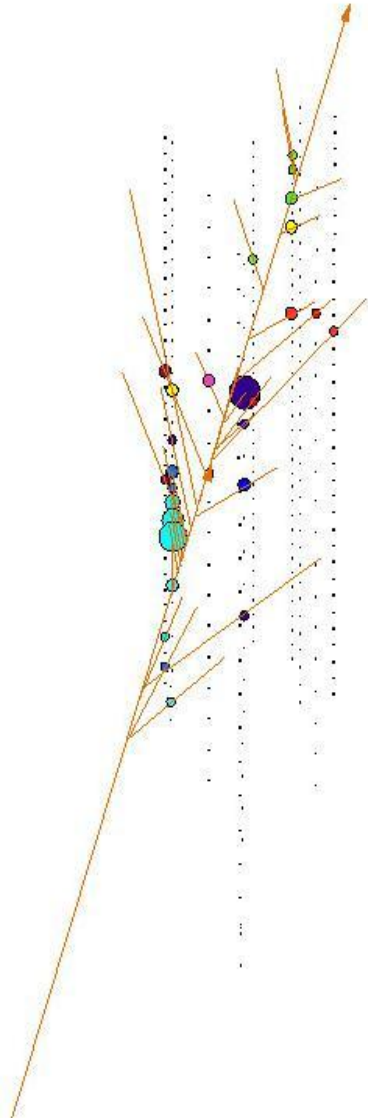

Up to now: No significant point sources but just neutrinos from cosmic ray interactions in the atmosphere were found .

→ Ice Cube for more statistics !

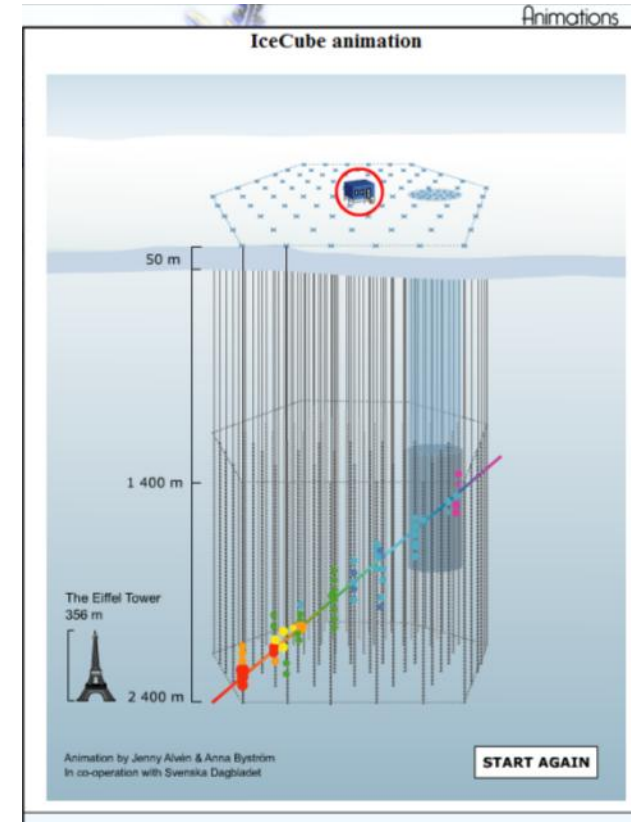

CERN Neutrino Gran Sasso (CNGS)

CNGS

If neutrinos have mass:

Muon neutrinos produced at CERN.
See if tau neutrinos arrive in Italy.

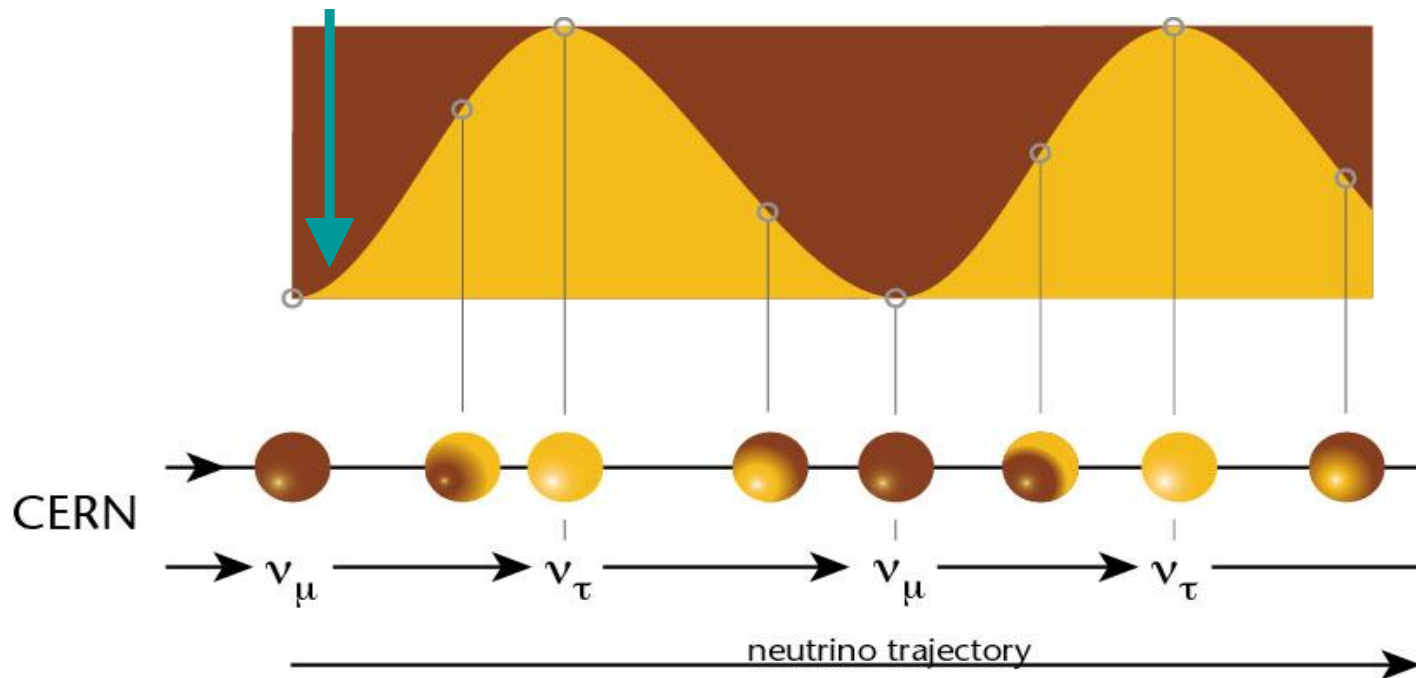
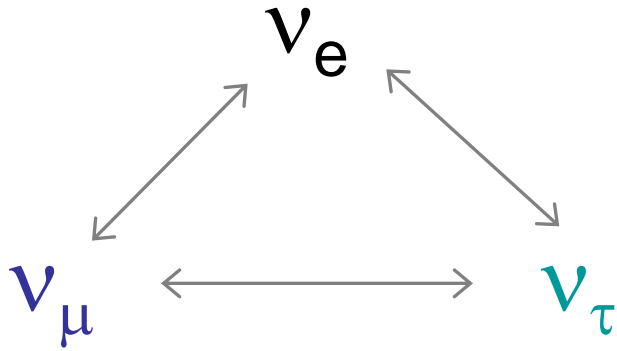

CNGS Project

CNGS (CERN Neutrino Gran Sasso)

- A long base-line neutrino beam facility (732km)
- send ν_{μ} beam produced at CERN
- detect ν_{τ} appearance in OPERA experiment at Gran Sasso



➔ direct proof of $\nu_{\mu} - \nu_{\tau}$ oscillation (appearance experiment)

CNGS

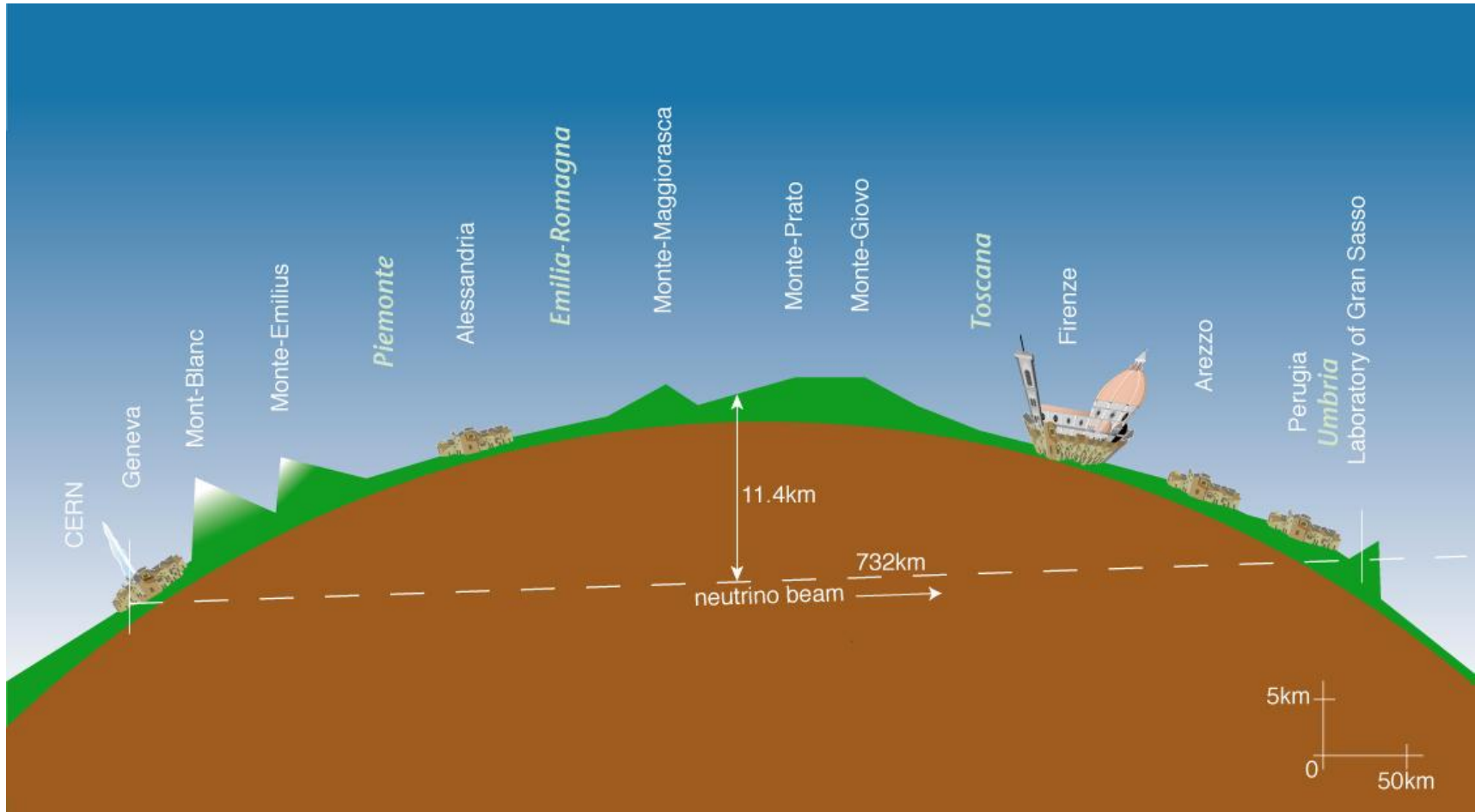

CNGS

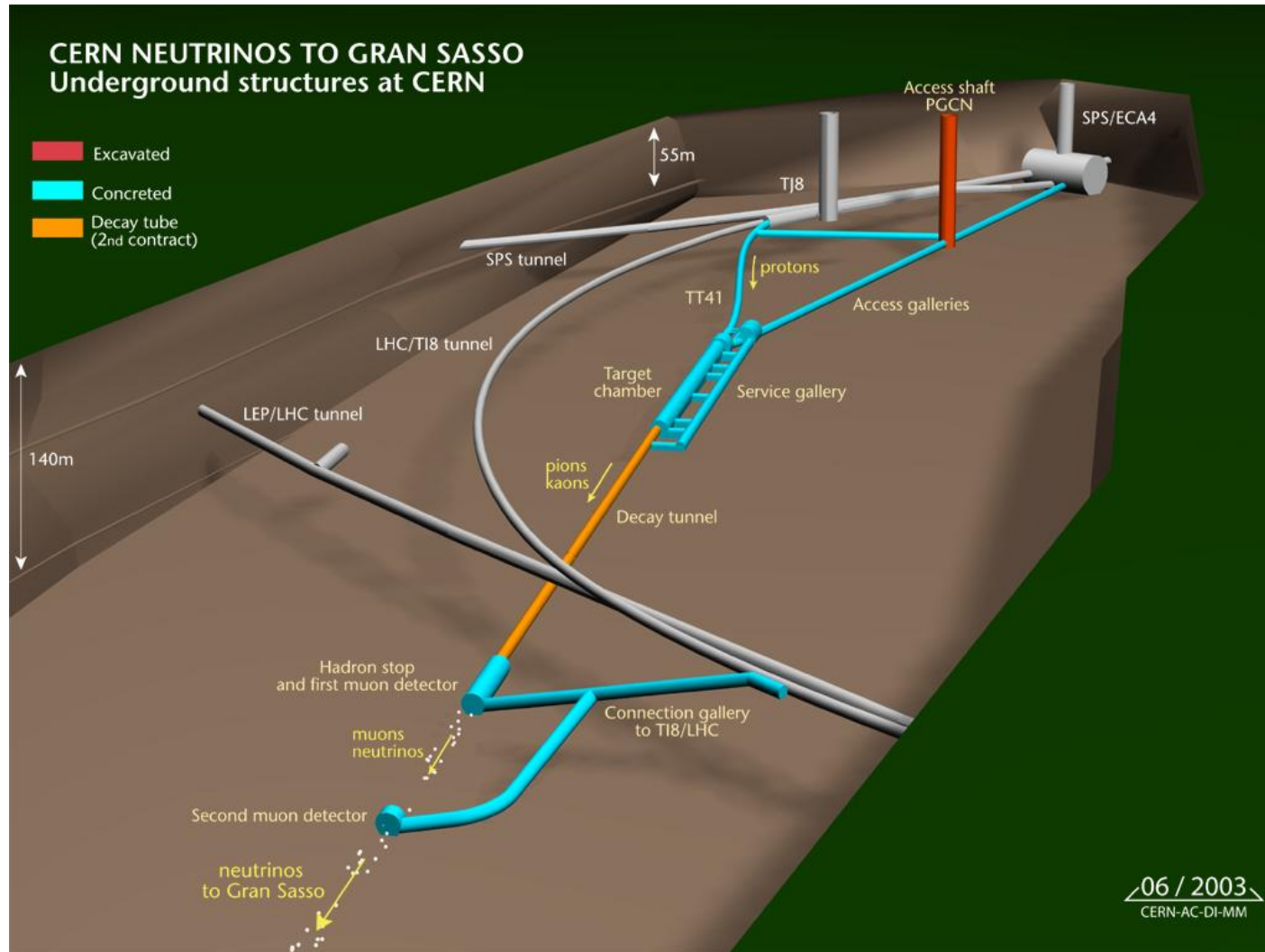

CNGS

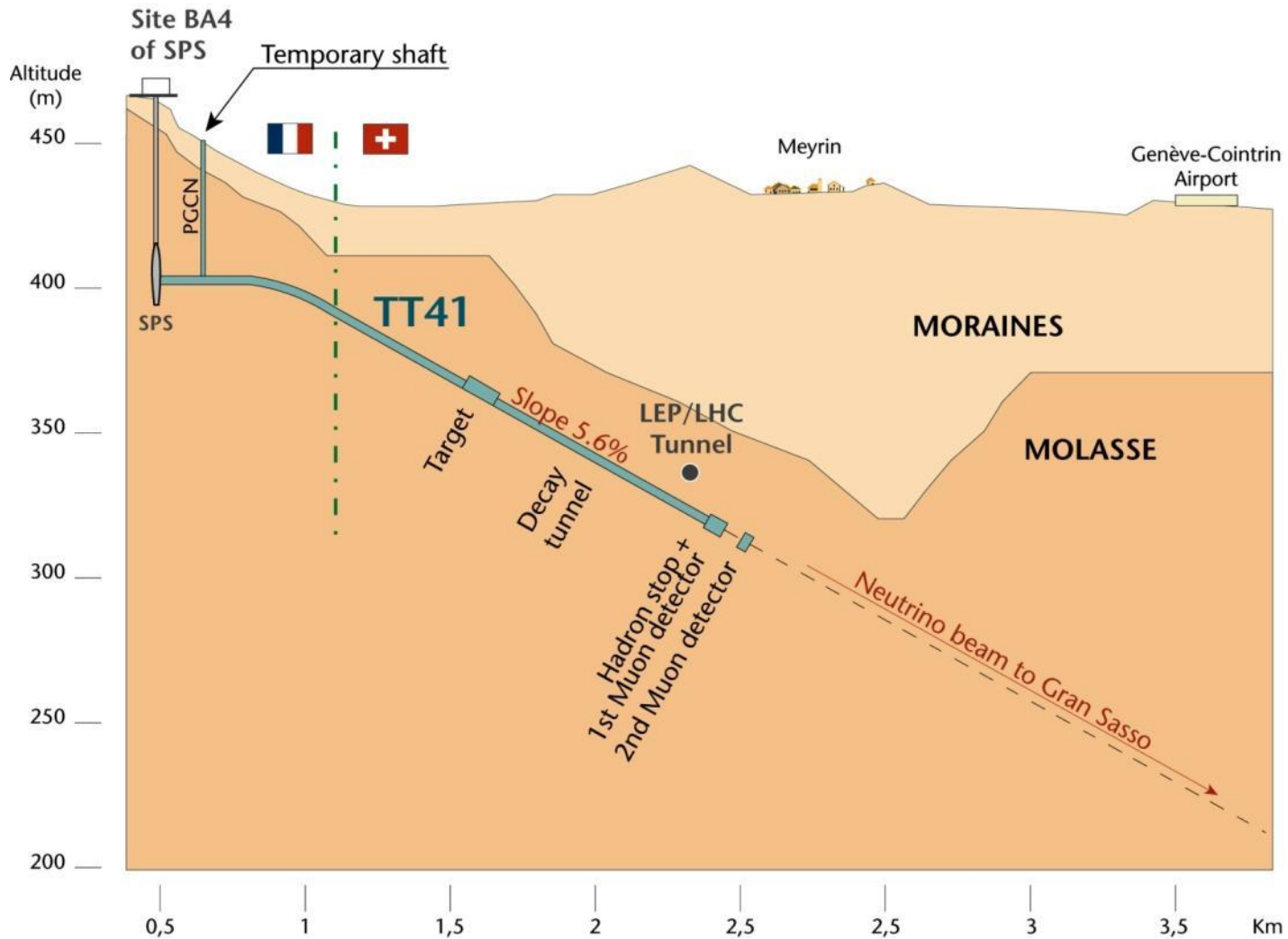

Radial Distribution of the ν_μ -Beam at GS

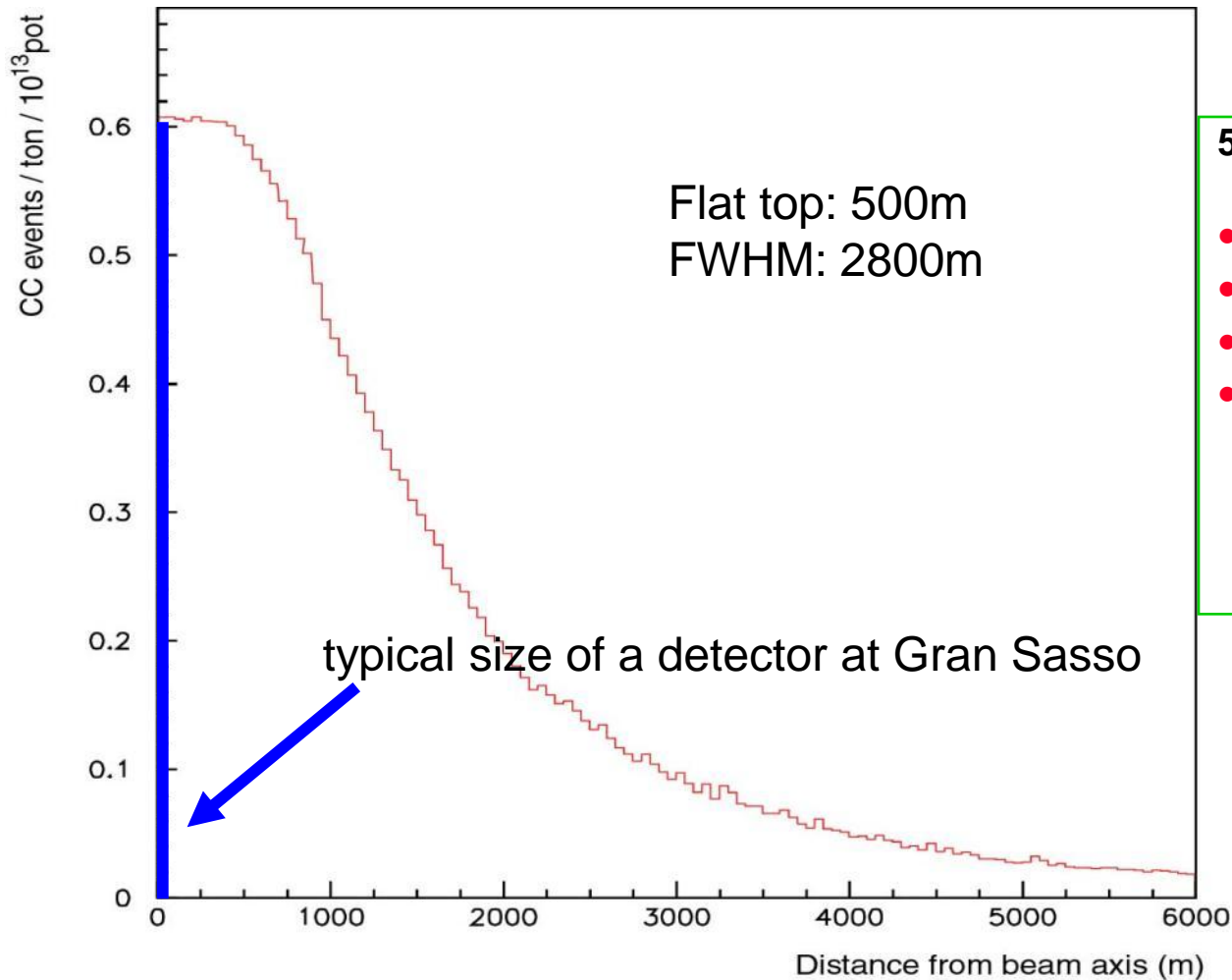

5 years CNGS operation, 1800 tons target:

- **30000 neutrino interactions**
- **$\sim 150 \nu_\tau$ interactions**
- **$\sim 15 \nu_\tau$ identified**
- **< 1 event of background**

Neutrinos at CNGS: Some Numbers

For 1 year of CNGS operation, we expect:

| | |
|--|--------------------|
| protons on target | 2×10^{19} |
| pions / kaons at entrance to decay tunnel | 3×10^{19} |
| ν_{μ} in direction of Gran Sasso | 10^{19} |
| ν_{μ} in 100 m^2 at Gran Sasso | 3×10^{14} |
| ν_{μ} events per day in OPERA | ≈ 2500 |
| ν_{τ} events (from oscillation) | ≈ 2 |

Opera Experiment at Gran Sasso

Basic unit: brick

56 Pb sheets + 56 photographic films (emulsion sheets)

Lead plates: massive target

Emulsions: micrometric precision

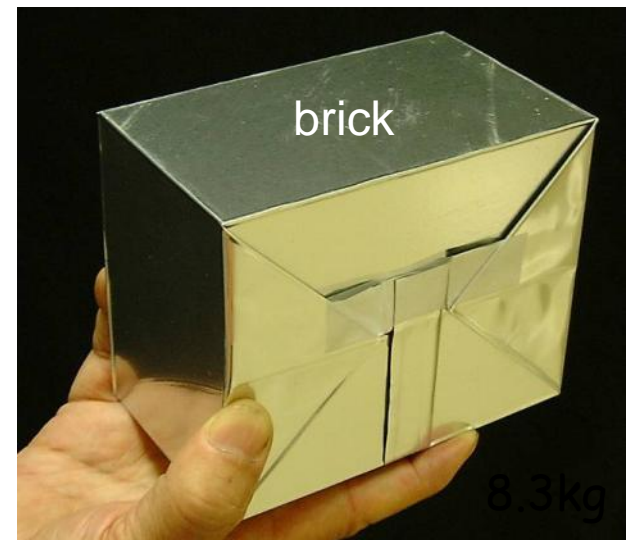
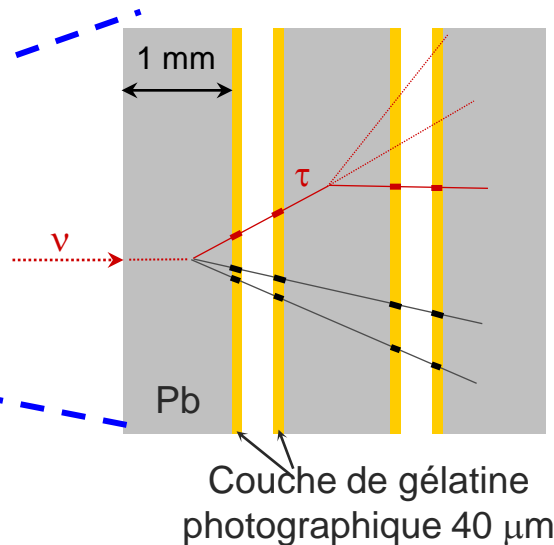
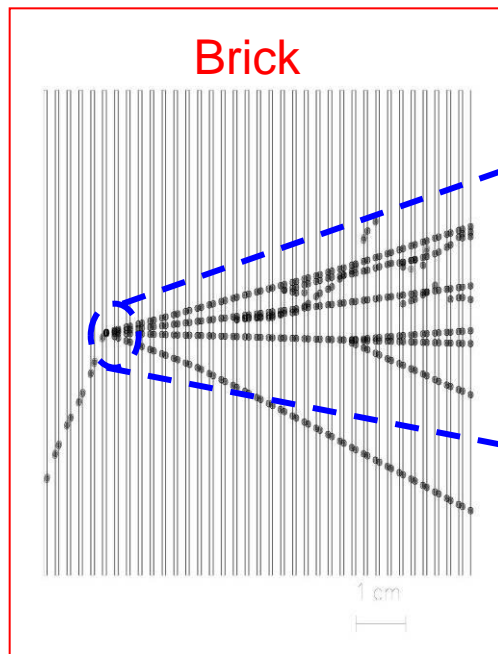

10.2 x 12.7 x 7.5 cm³

Opera Experiment at Gran Sasso



31 target planes / supermodule

In total: 206336 bricks, 1766 tons

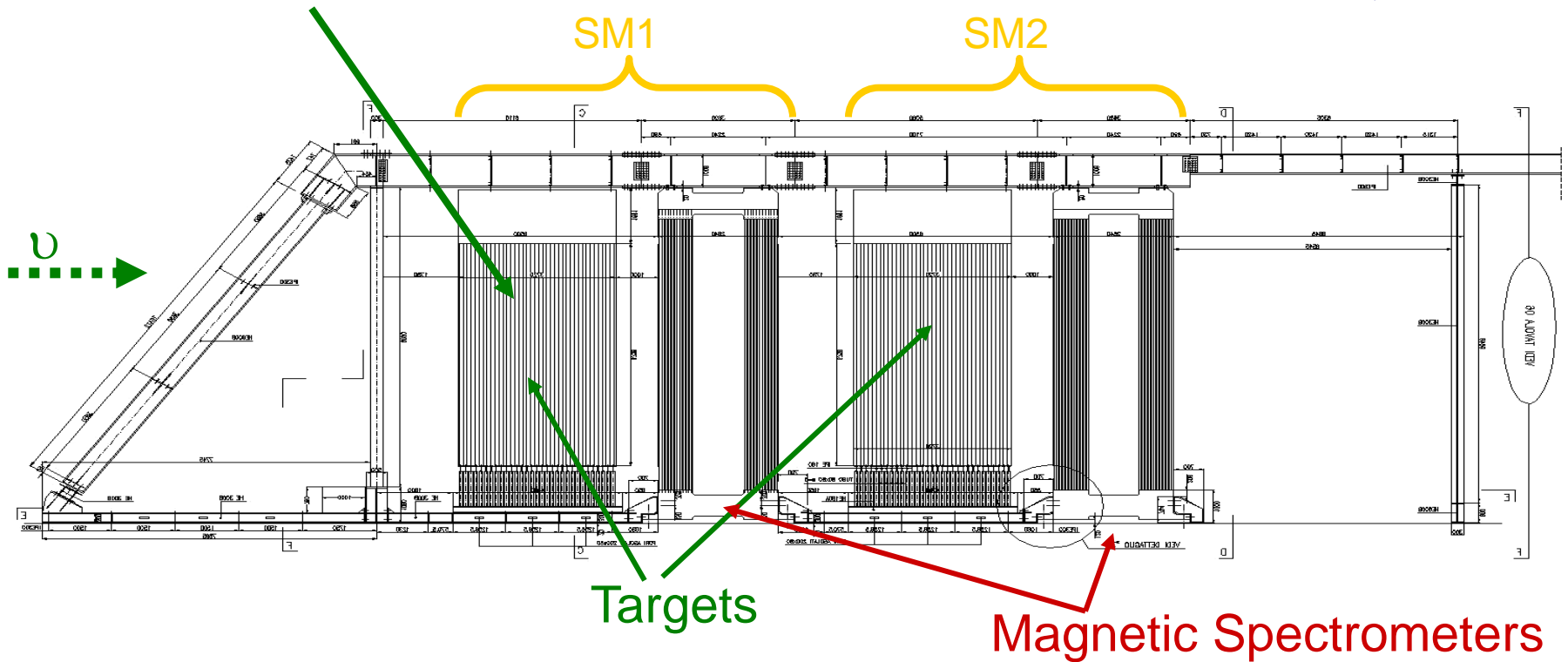

First observation of CNGS beam neutrinos : August 18th, 2006

Opera Experiment at Gran Sasso



Second Super-module



Scintillator planes 5900 m²
8064 7m long drift tubes

Details of the first spectrometer

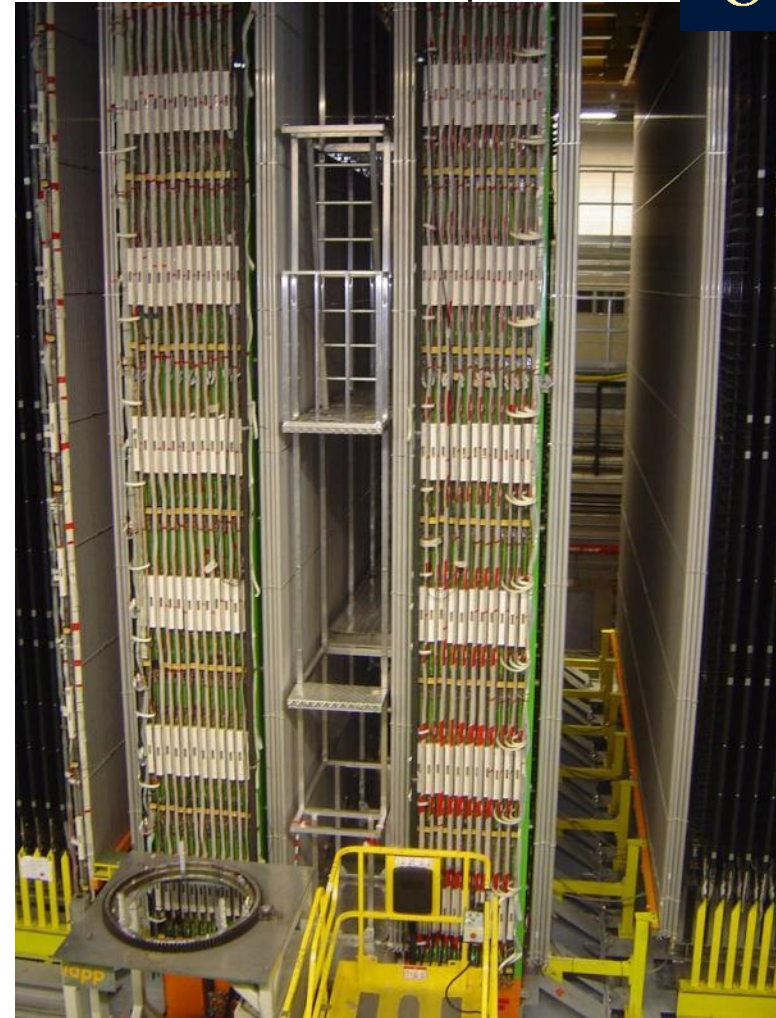

3050 m² Resistive Plate Counters
2000 tons of iron for the two magnets

Opera Experiment at Gran Sasso

The Brick Manipulator System (BMS) prototype:
a lot of fun for children and adults !

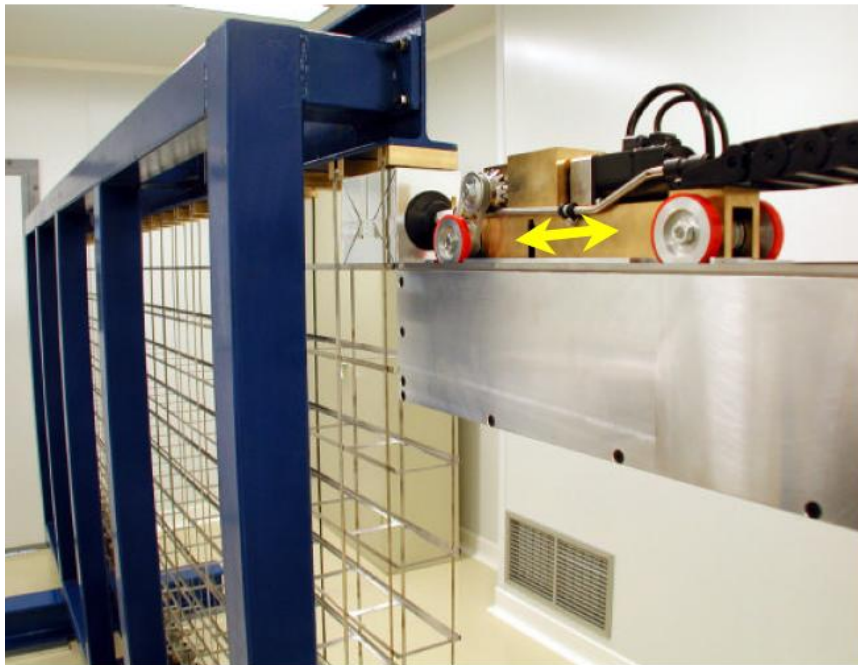
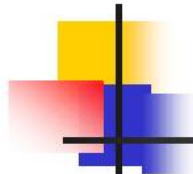

Tests with the prototype wall

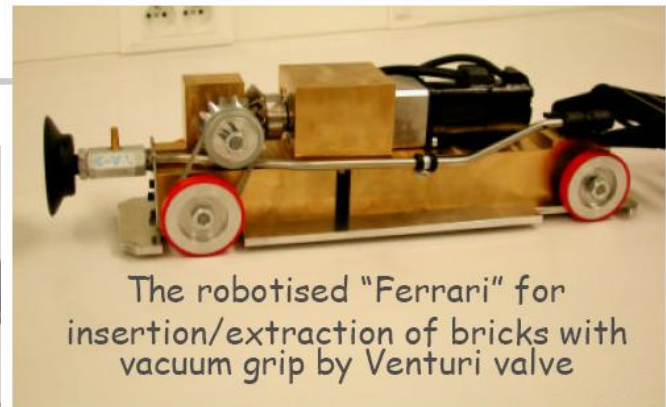

The robotised "Ferrari" for
insertion/extraction of bricks with
vacuum grip by Venturi valve



"Carousel" brick dispensing
and storage system

First Tau Candidate seen a few weeks ago !

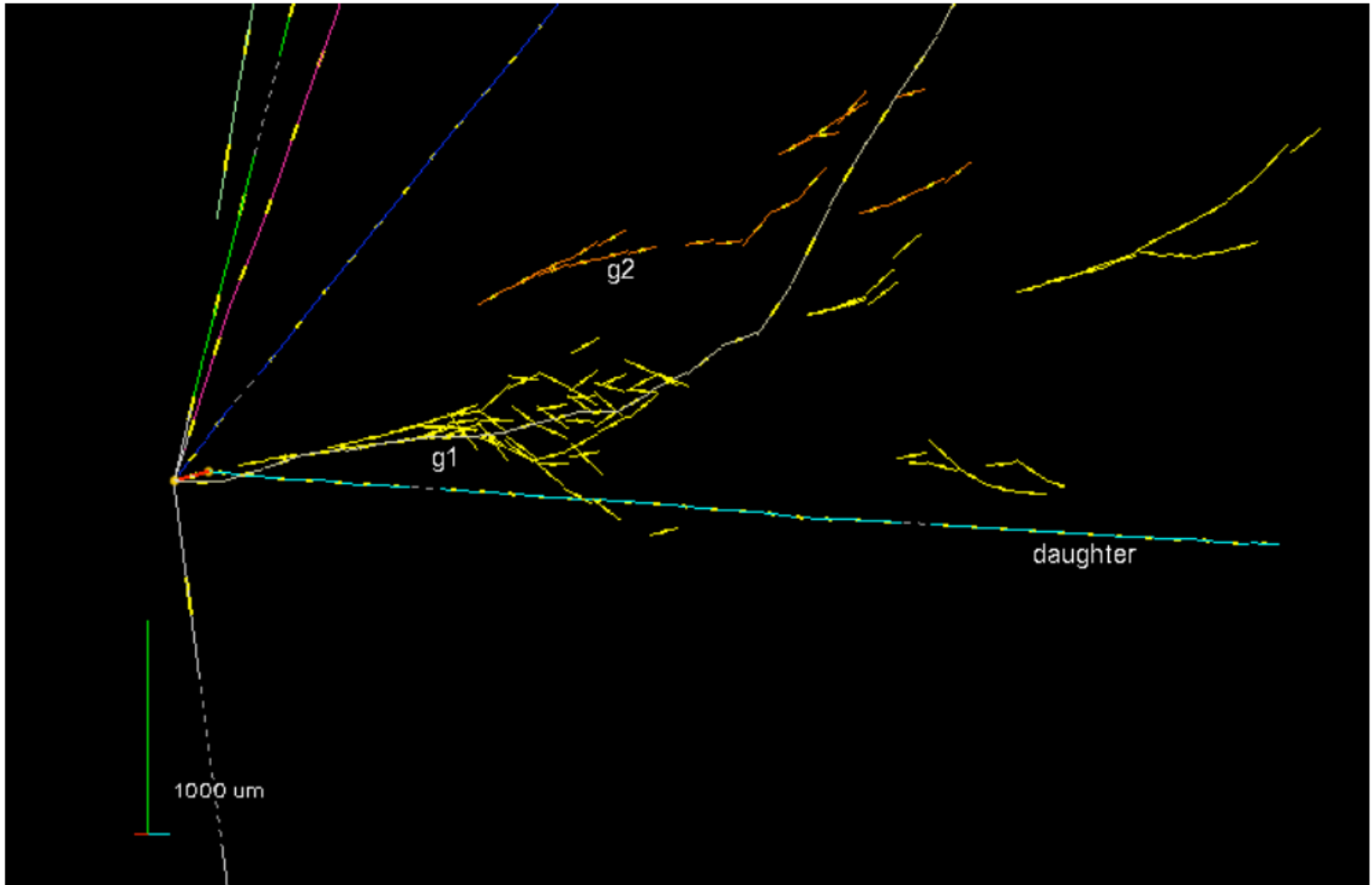



AMS

Alpha Magnetic Spectrometer

Try to find Antimatter in the primary cosmic rays.
Study cosmic ray composition etc. etc.

AMS

Will be installed on the space station.

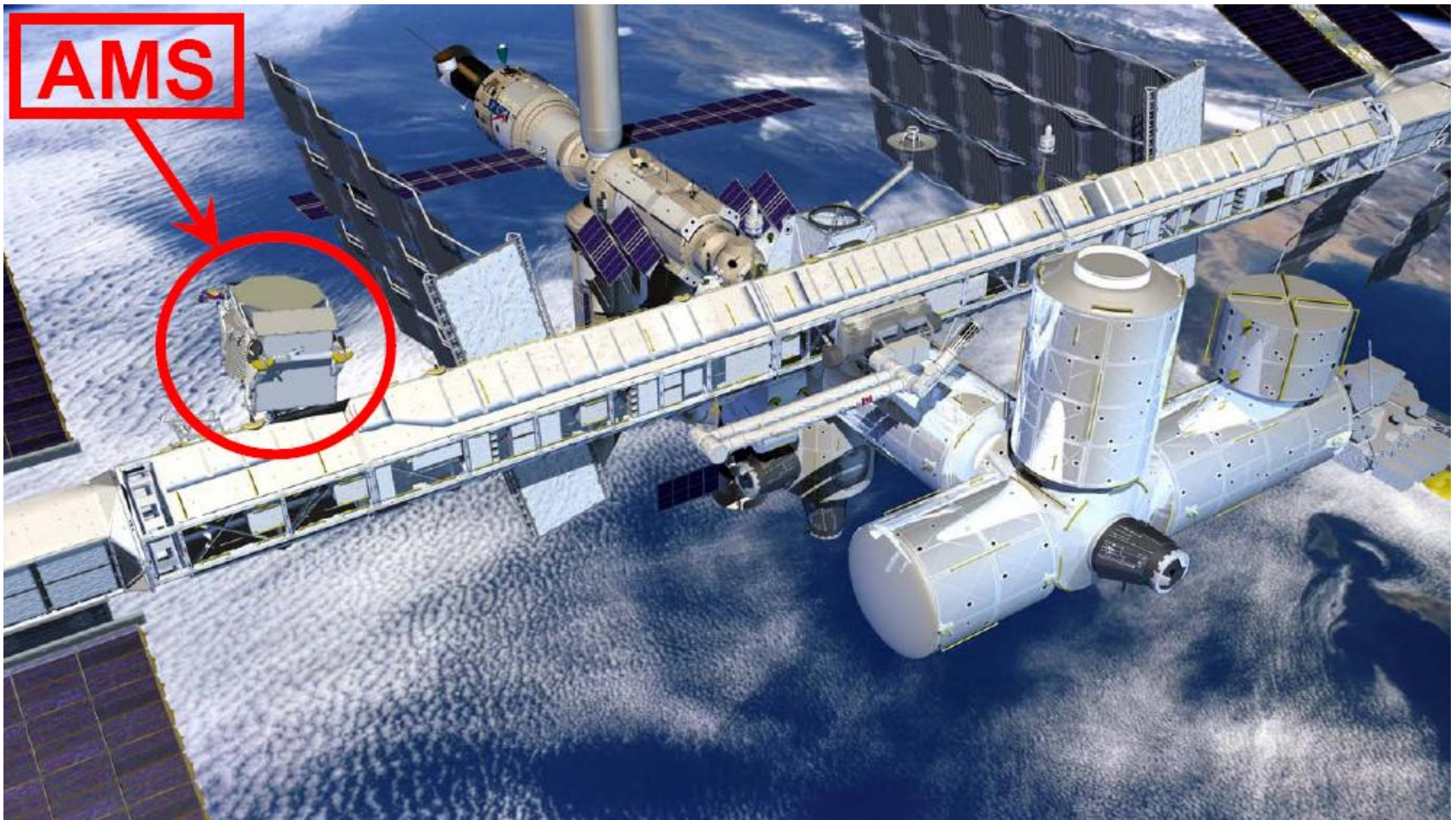

AMS

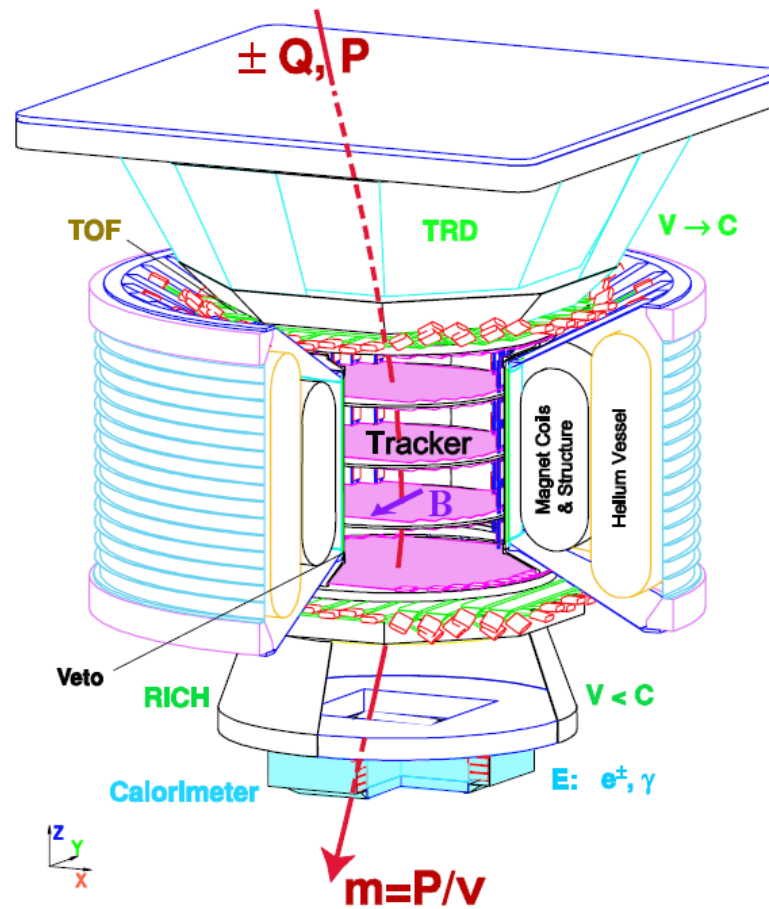

AMS

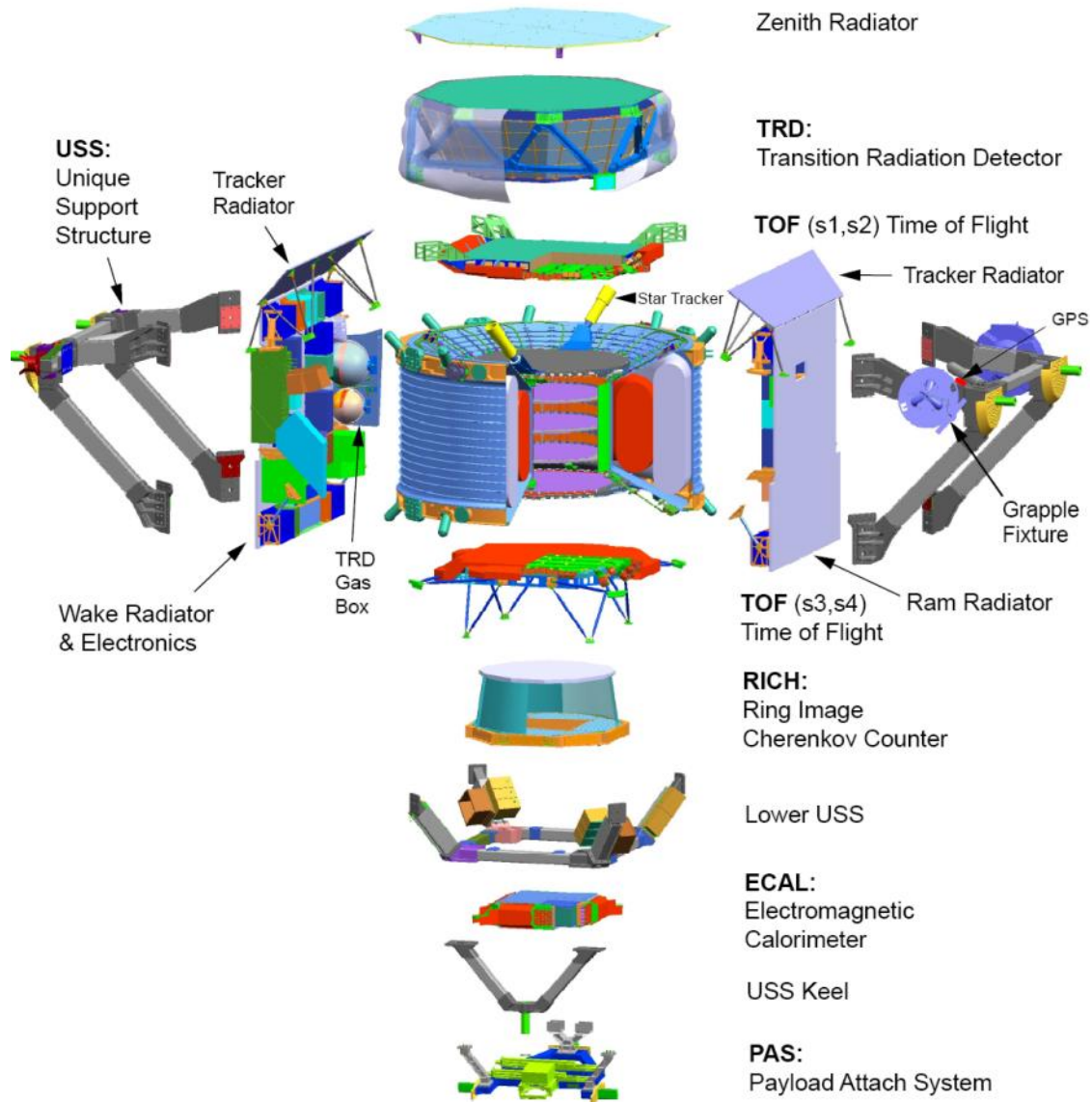



Pierre Auger Cosmic Ray Observatory

Pierre Auger Cosmic Ray Observatory

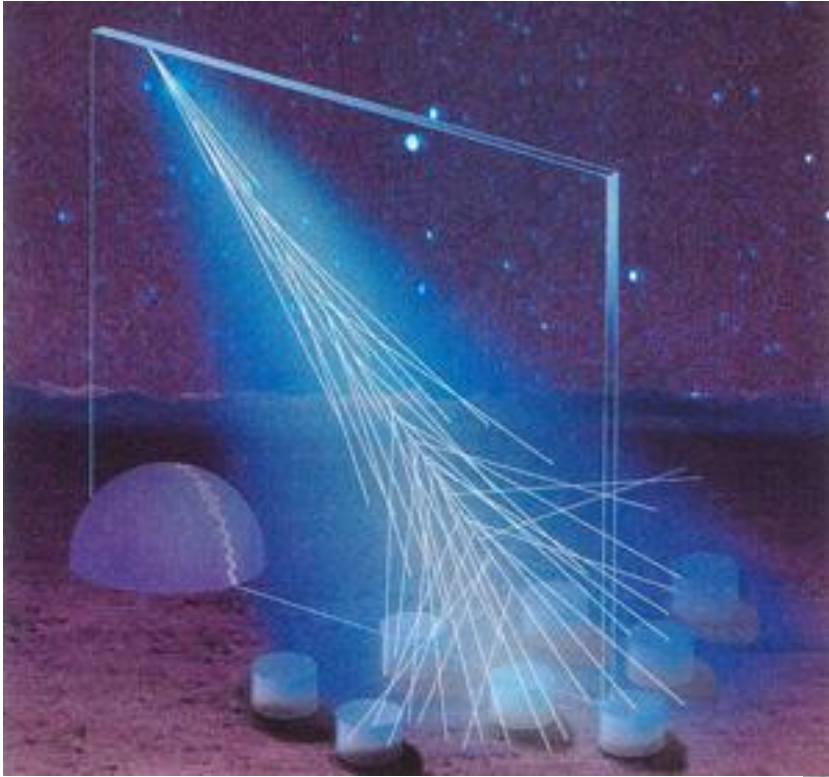

Use earth's atmosphere as a calorimeter. 1600 water Cherenkov detectors with 1.5km distance.

Placed in the Pampa Amarilla in western Argentina.



Pierre Auger Cosmic Ray Observatory

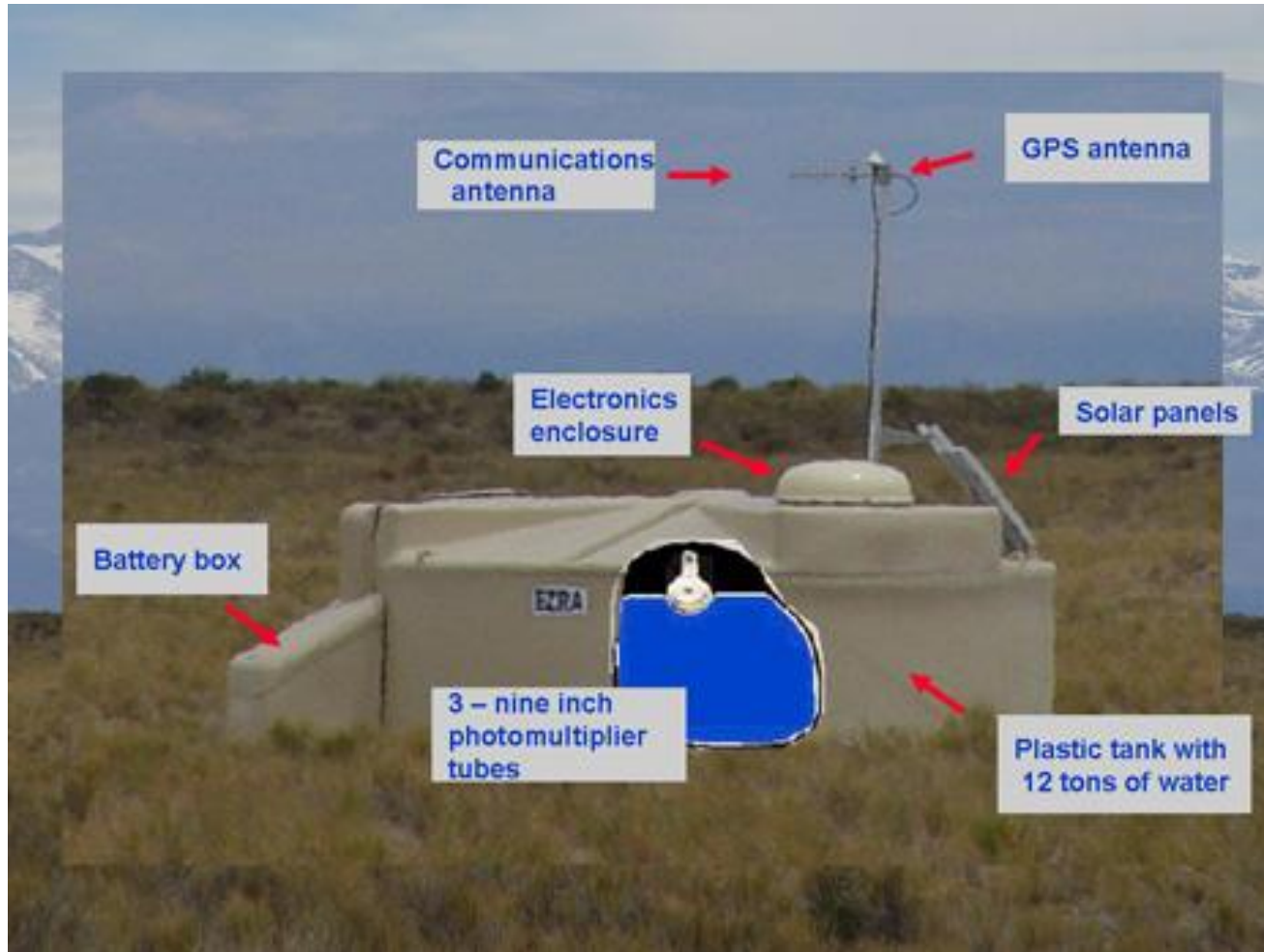

Pierre Auger Cosmic Ray Observatory

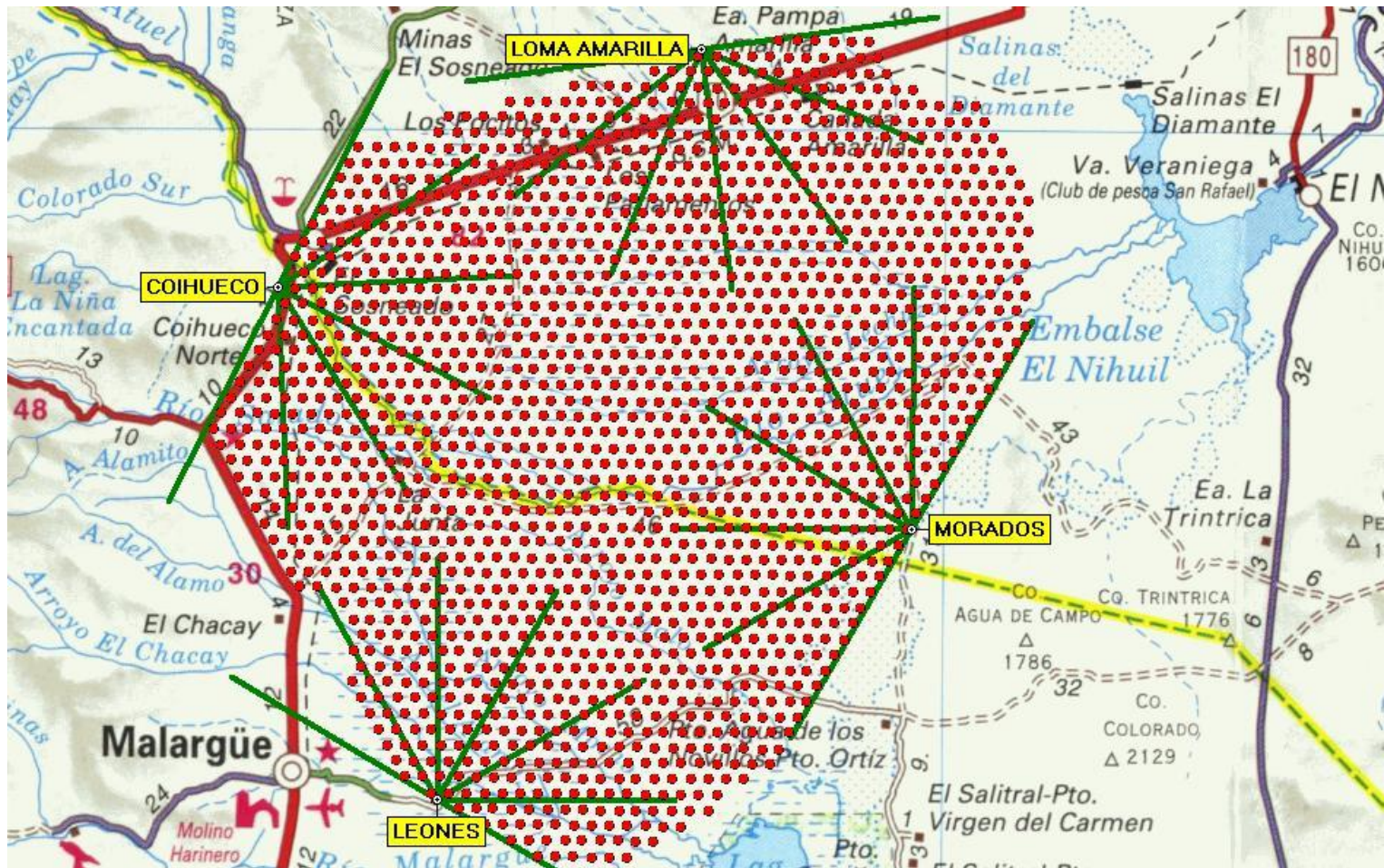

Pierre Auger Cosmic Ray Observatory

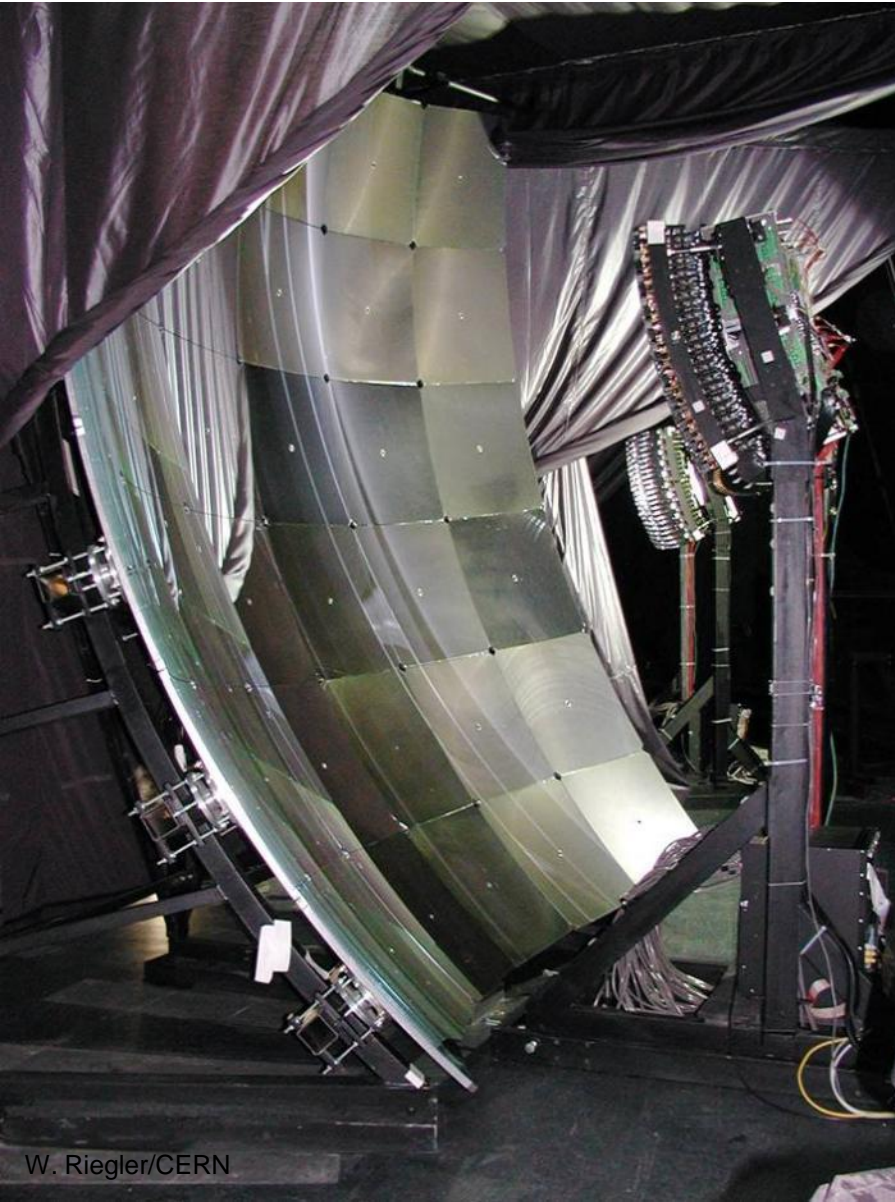

In addition: Fluorescence detectors around the array of water tanks.



Event 1234800

[See CR incoming direction](#) | [See individual station data](#)

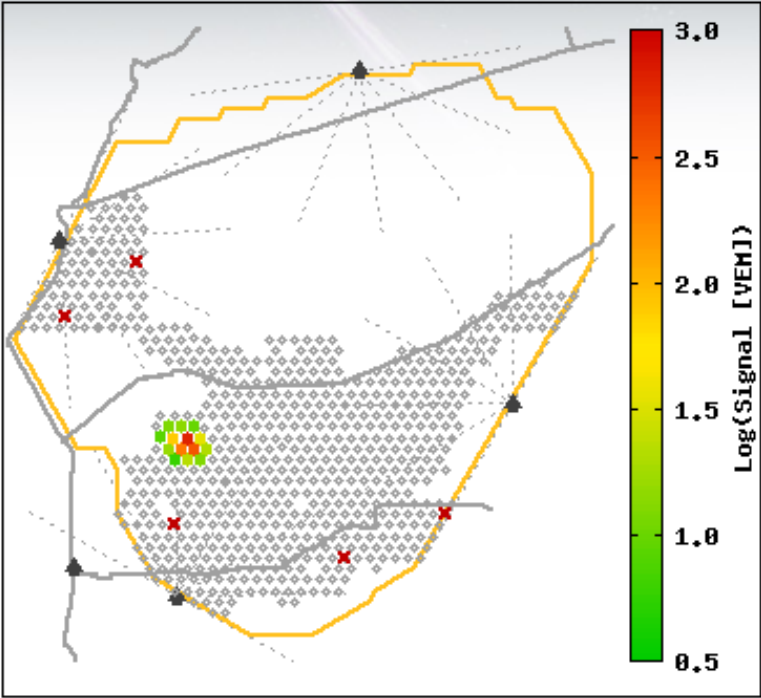

37 EeV = Exa Electron Volt = 37×10^{18} eV

| Generic Information | |
|---------------------|-------------------------|
| Id | 1234800 |
| Date | Sat Mar 5 15:54:48 2005 |
| Nb Station | 14 |
| Energy | 37.4 ± 1.2 EeV |
| Theta | 43.4 ± 0.1 deg |
| Phi | -27.3 ± 0.2 deg |
| Curvature | 15.8 ± 0.8 km |
| Core Easting | 460206 ± 20 m |
| Core Northing | 6089924 ± 11 m |
| Reduced χ^2 | 2.30 |

Event 1234800

[See event reconstruction data](#) | [See CR incoming direction](#)

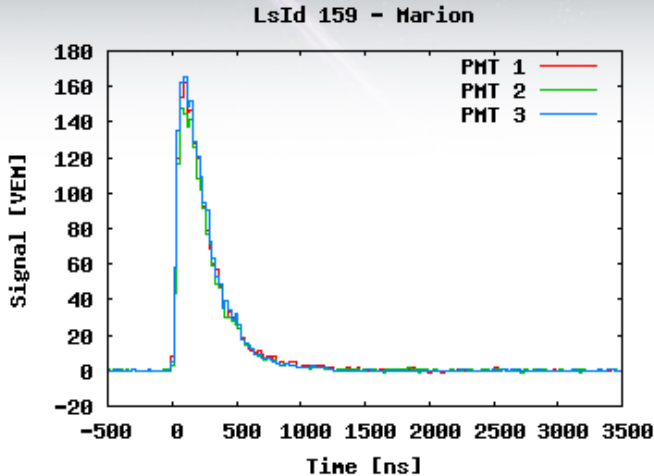

Signal in VEM for the 3 PMTs of station 159 (Marion) as a function of time

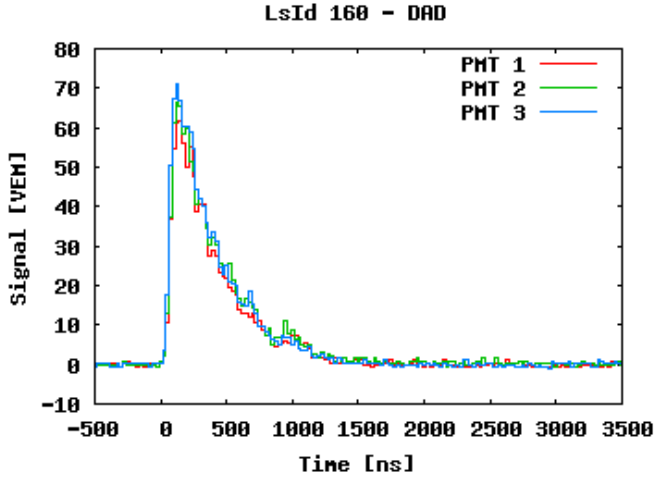

Signal in VEM for the 3 PMTs of station 160 (DAD) as a function of time

A few Reasons why you want to become an Experimental Particle Physicist

The Standard Model of Particles Physics, a theory that was established in the early 1970ies, is in excellent agreement with experiments. Especially the LEP experiments verified the theory to impressive precision.

The Higgs Particle, a necessary element of the standard model, is being hunted at LHC.

Although the standard model is perfectly fitting the experiment, we know/think that it cannot be the final answer:

CP violation and the other CKM matrix elements are put into the model explicitly and they are not derived from a theory.

The masses of the particles are also unexplained.

The Matter- Antimatter asymmetry in the Universe cannot be explained by the level of standard model CP violation.

The cosmological constant predicted by the standard model differs by 120 orders of magnitude from the observed one.

The Higgs mass renormalization requires fine tuning operations etc. etc.

A few Reasons why you want to become an Experimental Particle Physicist

Incredible efforts by the smartest theorists did not really advance on these questions and did not touch base with experiment.

It is very difficult to find out what is wrong with the theory if all experimental results are fitting the theory.

If we would find the standard model Higgs at LHC it would be an very impressive confirmation of the Standard Model, but we would not at all advance on the questions quoted earlier.

Hopefully we find something in contradiction with the Standard Model !!!

The next step in advancing our knowledge will come from Experiment. Maybe LHC or some telescope, or some astrophysics experiment or some other future accelerator ...

We have to invent new technologies for future accelerators and experiments !

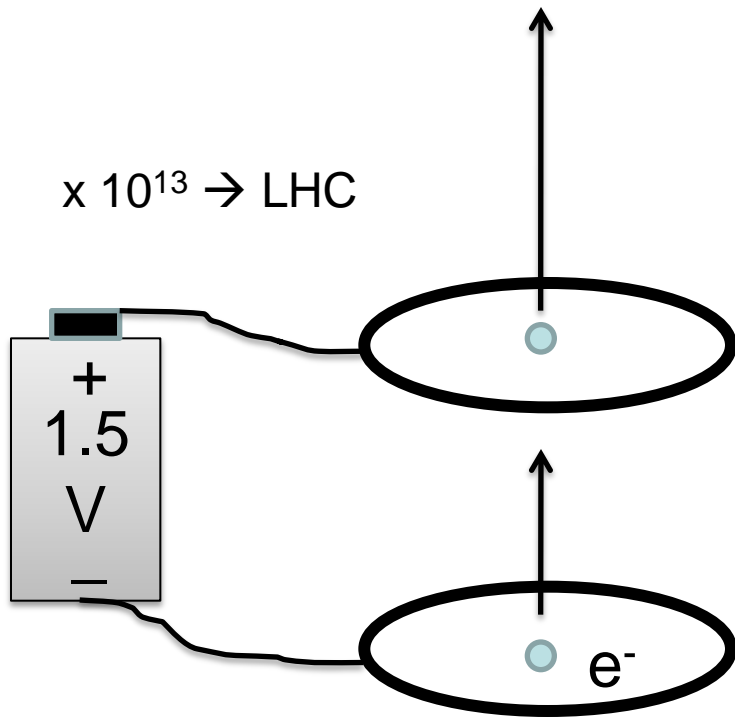

Physicist 1: How can we build an accelerator with 10 times more energy ?

Physicist 2: Hmm – I have an idea !! We build a 10 times larger accelerator !

You

have to develop the tricks and technologies to advance on the most fundamental questions of Physics !