



Massimiliano Putignano

DITANET PhD Student

**Development of a Beam Profile Monitor Based
on a Supersonic Gas-Jet Curtain**

Website:

www.quasar-group.org

Email: massimiliano.putignano@quasar-group.org



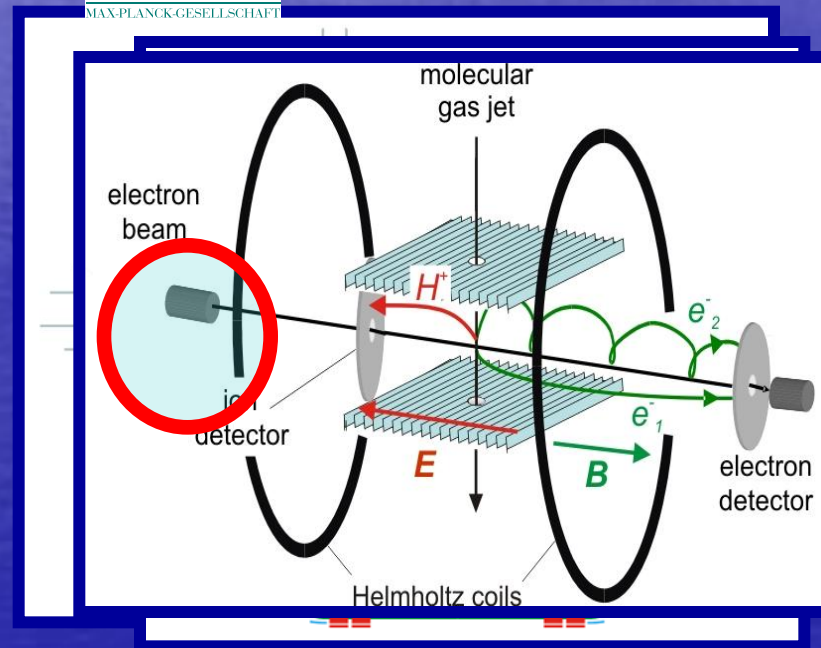

- Low Energy Antiprotons



Project definition

Significance - **Definition** - Specifications - Working Principle - Simulations - Experiment

1. **What** exactly do we need?

Specifications

2. Is our project **realistic**?
Is it likely to really work?

Theory &
Simulations

3. Does it **actually** work?

Experiment



What exactly do we need? → Specifications

Significance - Definition - **Specifications** - Working Principle - Simulations - Experiment

- **Non destructive** to:

- **Vacuum**

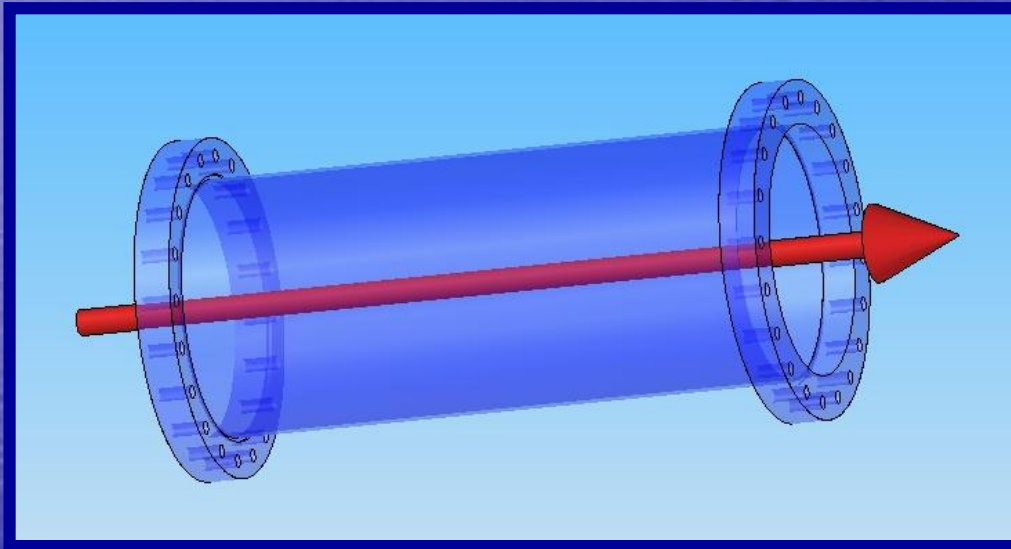

- **Beam**

- **Wallet!**



How is it done? → Working Principle

Significance - Definition - Specifications - **Working Principle** - Simulations - Experiment

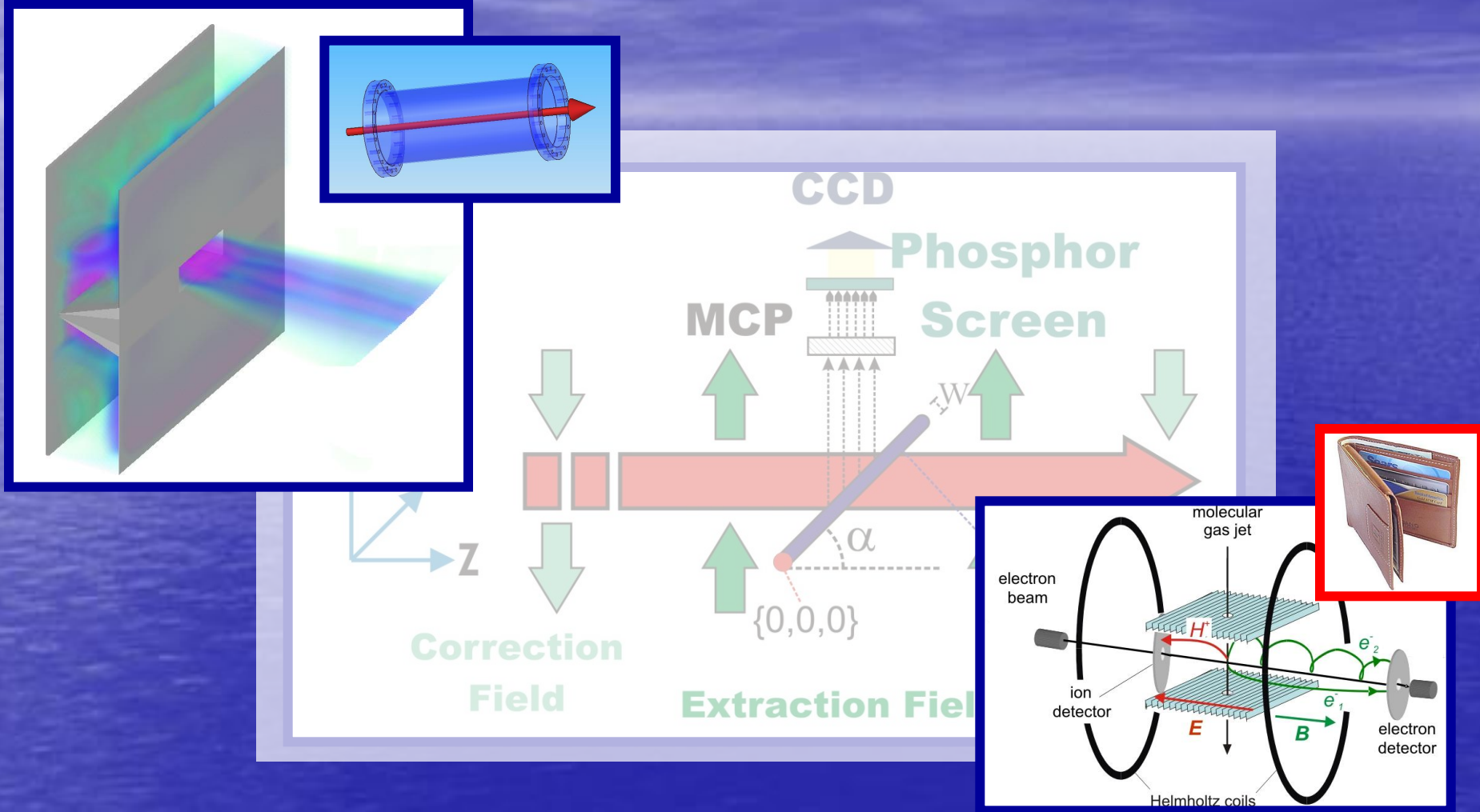

- **Parameters:**

- Resolution
- Confinement
- Accuracy

- **Variables:**

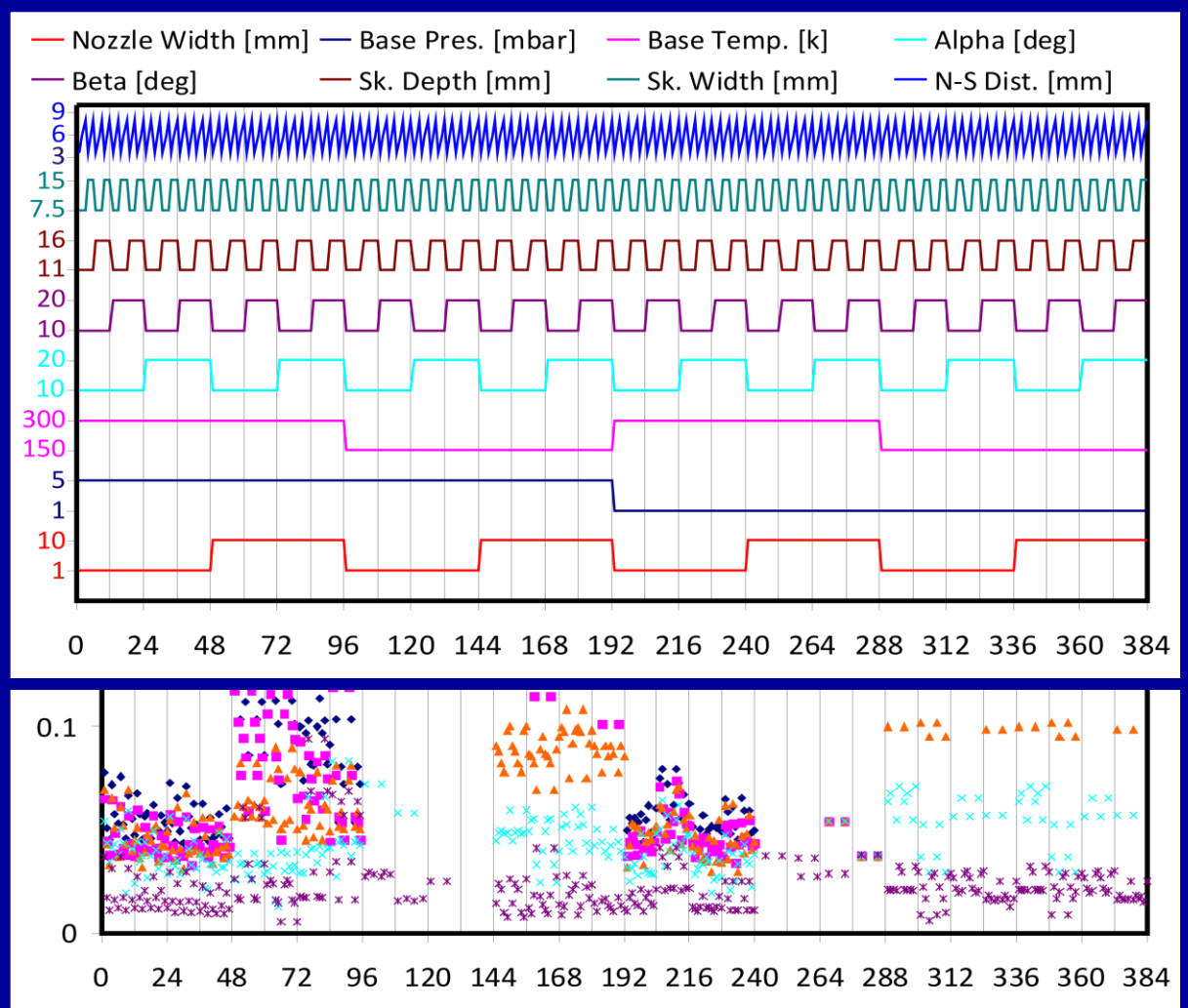
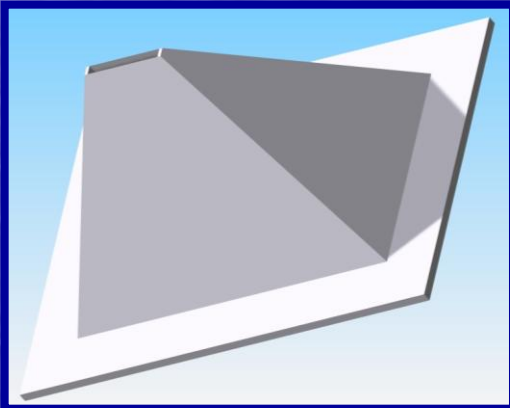



Does it **actually work?** - Experiment

Significance - Definition - Specifications - Working Principle - Simulations - **Experiment**

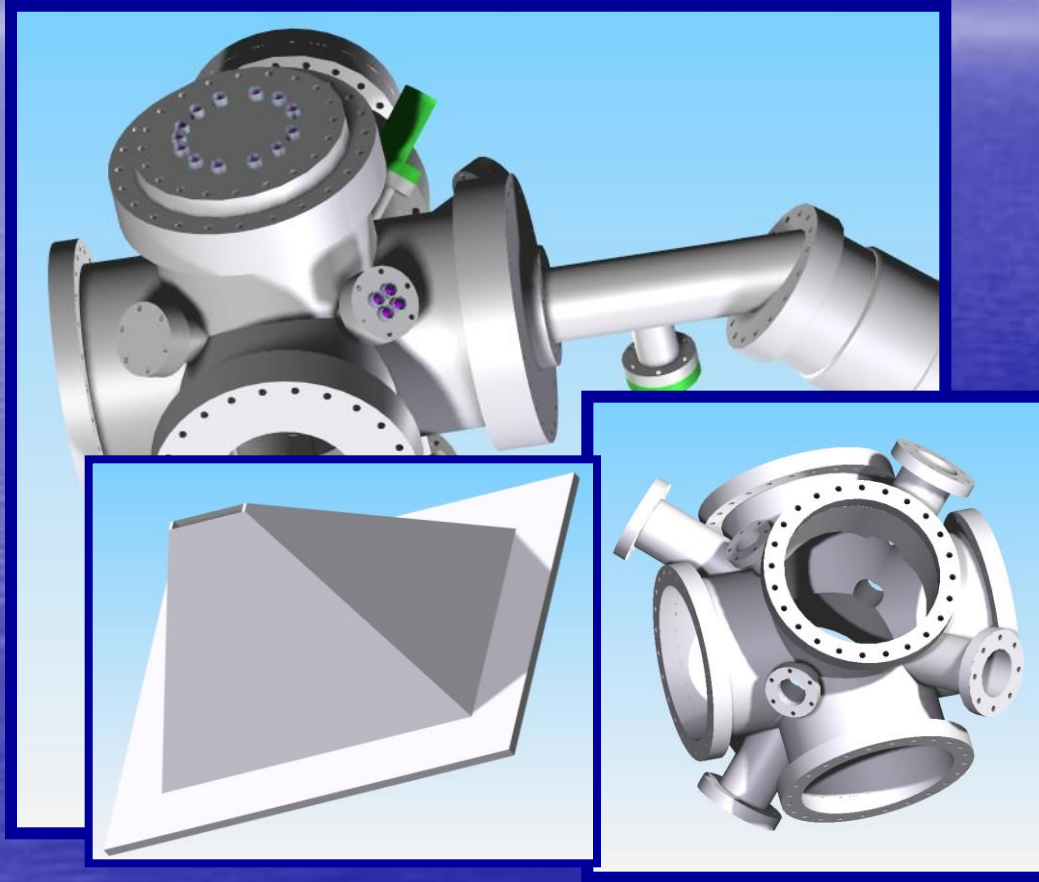



Time's up...

Significance - Definition - Specifications - Working Principle - Simulations - Experiment

*Thank you
for your attention*

