

FCC-ee* beam diagnostics, beam tests, and support structures (a dynamic positioning strategy)

Gaël BALIK for the LAPP-FCC team

FCC IS kickoff meeting, 10 November 2020

* The Future Circular Collider Innovation Study (FCCIS) project has received funding from the European Union's Horizon 2020 research and innovation programme under grant No 951754.

INTRODUCTION

- Context
- Introduction to accelerator structure alignment

STATE OF THE ART

- Common positioning system technology
- ESRF - EBS storage ring
- PSI - Swiss Light Source (SLS)
- KEK - Accelerator Test Facility (ATF2)
- CERN - The Compact Linear Collider (CLIC)
- CERN - Future Circular Collider (FCC-ee)

CONCLUSION

The FCC-ee will be the most demanding project in terms of positioning accuracy over a circle with nearly 100km circumference and around 2900 main quadrupole magnets

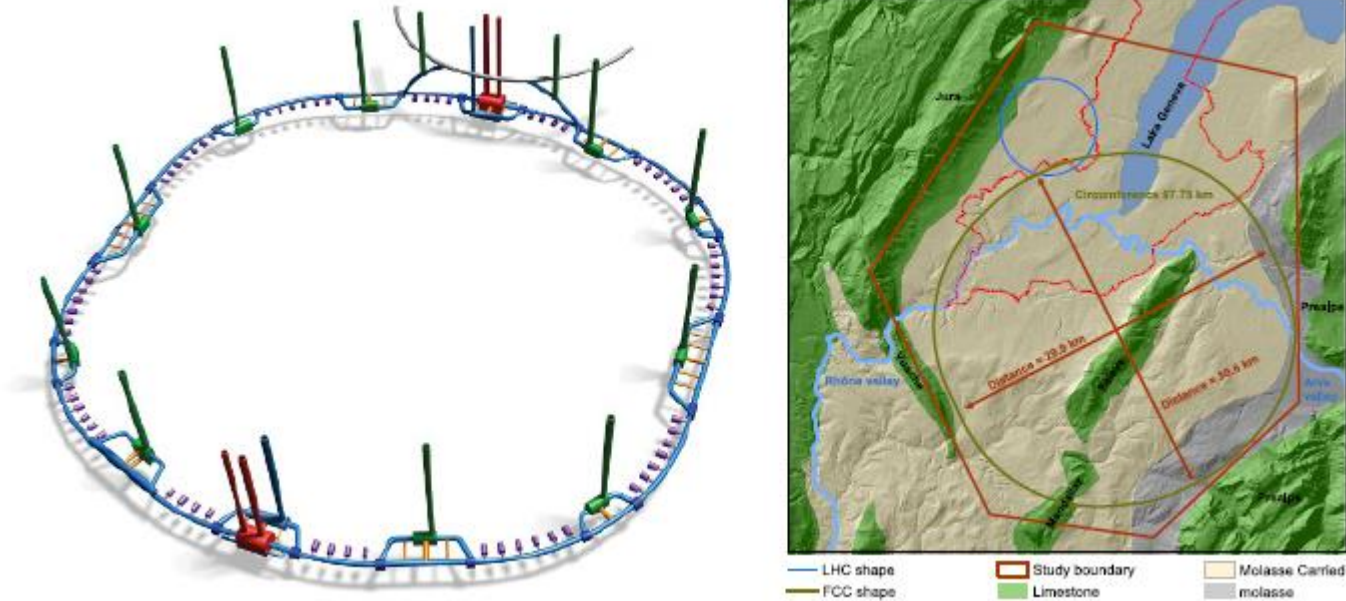

Schematic of the underground structures - Main topographical and geological structures

Present technical possibilities have to be compared to future physics requirements, to define which developments need to be undertaken

The alignment requirements for past and future collider are defined for 3 distinct operational.

Beam off

- During machine set-up prior to operation for physics production, a good relative alignment of accelerator structures and quadrupoles
- After a probe beam is successfully sent along the whole linac, beam-based methods that involve beam measurements and quadrupole position tuning are used to optimize the machine
- Optimization of the luminosity performance during standard operation

Pre-alignment - alignment
positioning and optimization
strategies

And after ?

- Thermal variations
- Seismic activity / slow ground motion
- Slow drifts

Positioning of girder and magnets during operation for the most complex and stringent systems

- Magnets, ... (ATF2, CLIC)
- Girder (ESRF, SLS,...)

Dynamic
positioning



Beam On

How is positioning done

It depends on the size and specification of the accelerator

Mechanically and automatically

- with cam mover for specific components (i.e. magnets)
- with controlled systems such as hydrostatic leveling system (HLS)
- With a dedicated nano-positioning system

Permits the rapid realignment of the machine as soon as significant alignment deterioration is measured



More accurate, faster

Instrumentation (sensors)

- Hydrostatic Levelling System (HLS)
- Wire Positioning System (WPS)
- Seismometer
- Dedicated homemade sensor

- ESRF storage ring is composed of 129 girders
- The girders are all identical with a length about 5.1m and 6 tons
- A re-alignment of the girders in the vertical direction will be necessary every six months because of the medium-term displacements of the storage ring floor
- First natural frequency > 35 Hz
- Vibrations amplification factor (over 1-100 Hz) < 1.1

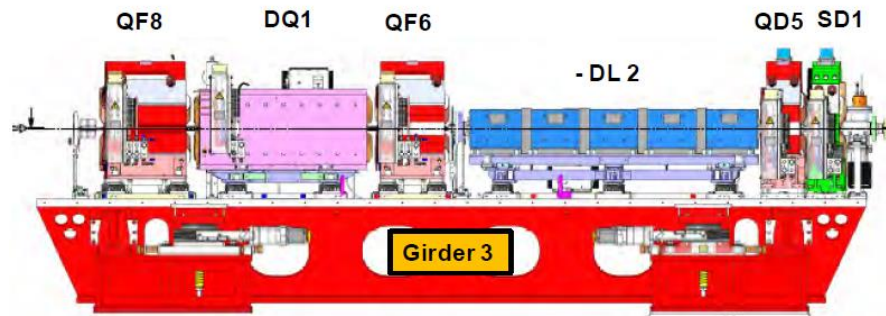

Girder 3 layout

- Each girder is equipped with a ± 5 mm motorized vertical adjustment and a ± 5 mm manual transverse adjustment with $5 \mu\text{m}$ resolution.
- And equipped with three Hydrostatic Leveling System (HLS) located immediately above

Three functions for the horizontal system:

- Horizontal adjustment (+/- 3,5 mm)
- Guiding the vertical movement
- Improving the girder stiffness

- Two jacks in the transversal direction allowing the translation and the yaw
- One jack longitudinal for the longitudinal adjustment

Vertical foot design.

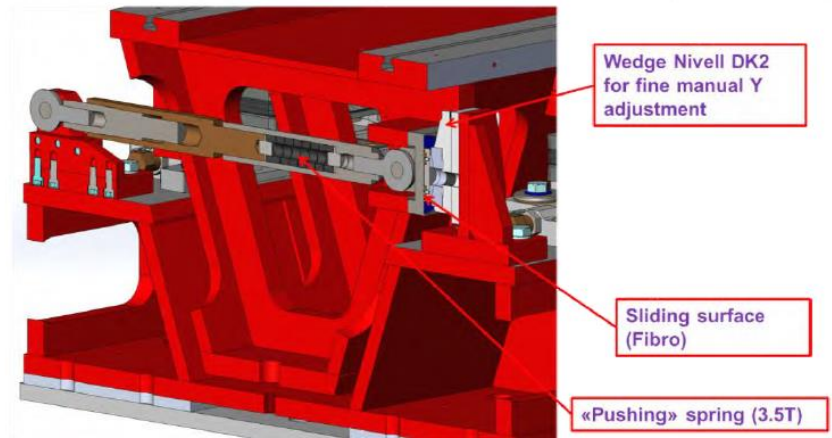
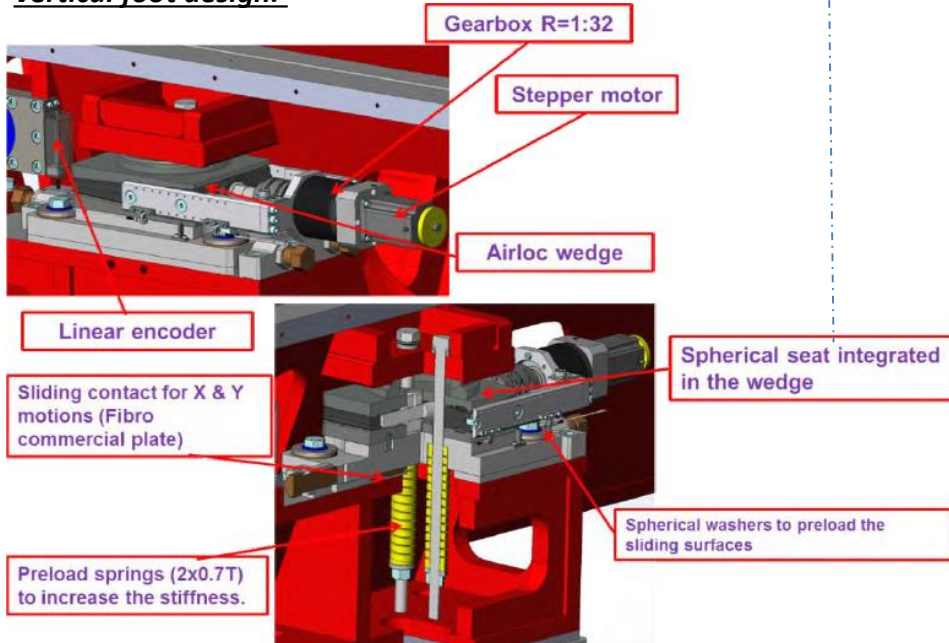

Horizontal foot design.

Four motorized supports in the vertical direction instead of three, permitting the adjustment of height, pitch and roll.

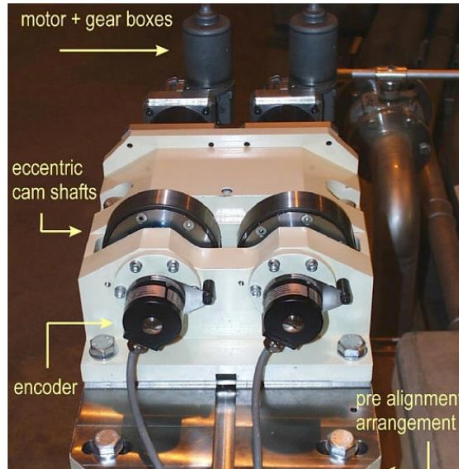

The girder mover system based on five DC motors per girder allows a dynamic realignment of the storage ring

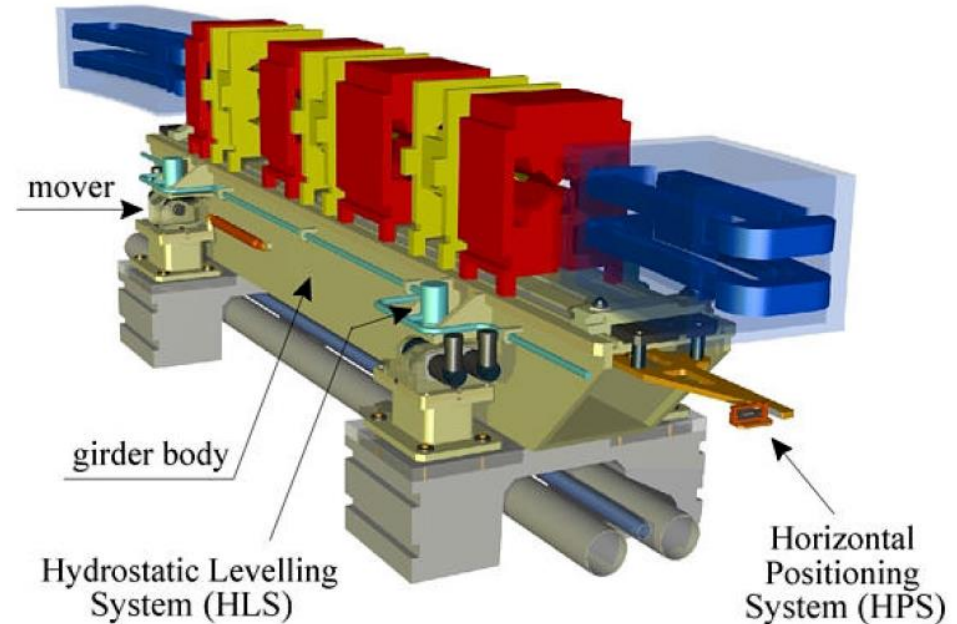

SLS storage ring girder assembly

The hydrostatic levelling system (HLS) gives an absolute vertical reference, while the horizontal positioning system (HPS), which employs low cost linear encoders with sub-micron resolution, measures relative horizontal movements

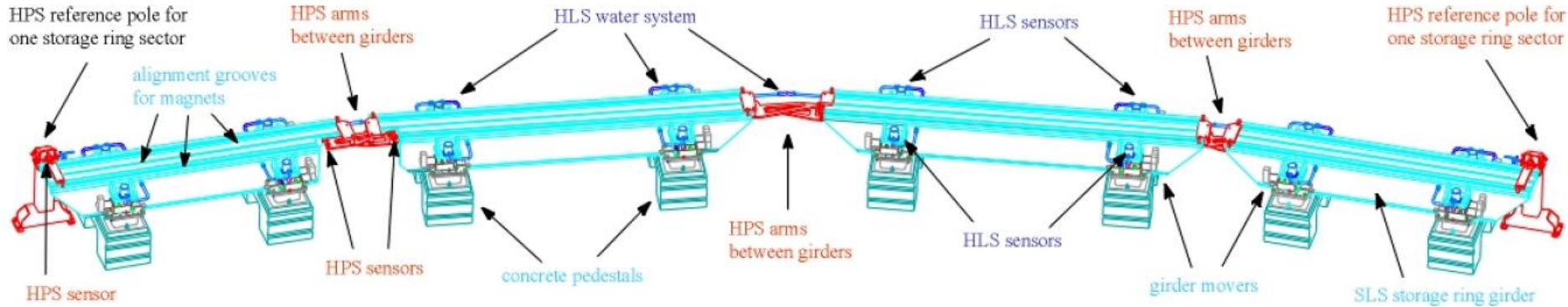

- Four girders form a chain containing 6 HPS sensors between girders and two at the outside reference poles allowing sway and yaw calculation from readouts
- The horizontal positioning system measures only relative movements between adjacent girders or between a girder and a reference pole on each side of a sector.
- Reference poles are extremely stiff and were constructed for minimal thermal expansion. Their positions are initially determined by the SLS survey and alignment group and checked during shut down periods.



HLS sensor with water pipe connection.

The 192 HLS sensors are connected by a stainless steel pipe of 25 mm diameter. The system was conceived to monitor any relative and global vertical position change with a resolution of $< 2 \mu\text{m}$ and within a working window of 2.5 mm.

20 quadrupole magnets and 3 sextupole magnets in the final focus area were put on remote-controlled 3- axis movers recycled from the FFTB at SLAC.

Each mover has three camshafts which allow adjustment in horizontal and vertical position (with precision of 1-2 μm) as well as rotation angle (tilt, with precision of 3-5 μrad).

- The camshaft driving motors are controlled through a CAMAC mover module.
- The potentiometer read backs of the camshaft rotation are read out through an ADC.
- There are also 3 LVDT on each mover magnet support plate which are read out via CAMAC modules.
- The interface to these modules is provided by an EPICS control system running in the CAMAC crate controller

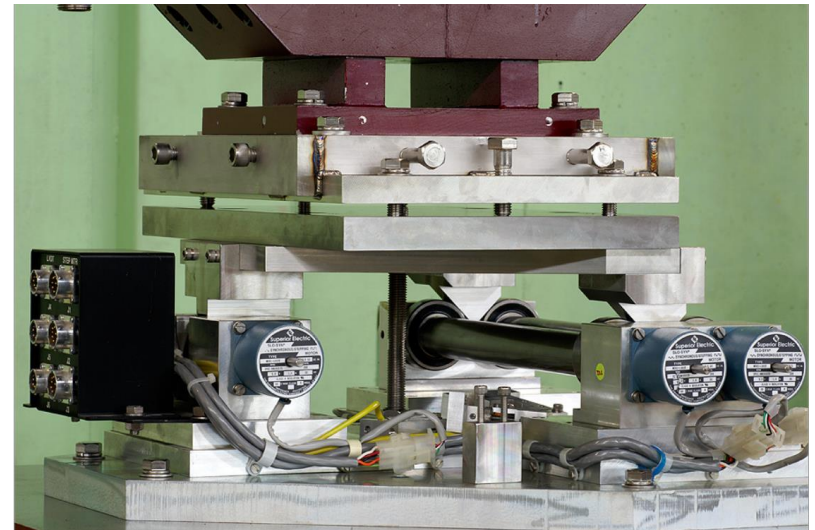

Magnet mover mechanism (from FFTB, SLAC)

Pre-alignment stage with beam off: cam-mover alignment system positioning with wire position sensor feedback system

Spec.:

- 4000 MBQ, each requiring active pre-alignment in 5 DOF
- Active pre-alignment within 17 μm in sliding windows of 200 m with respect to a straight reference line
- Provide a rigid support for the nano-stabilization system to ensure that the first eigenfrequency is above 100 Hz.

System

- Based on the cam mover from Swiss Light Source (SLS)
- The cam mover design was optimized together with the company ZTS VVU Kosice
- Feedback directly from alignment sensors (Wire Position Sensors)

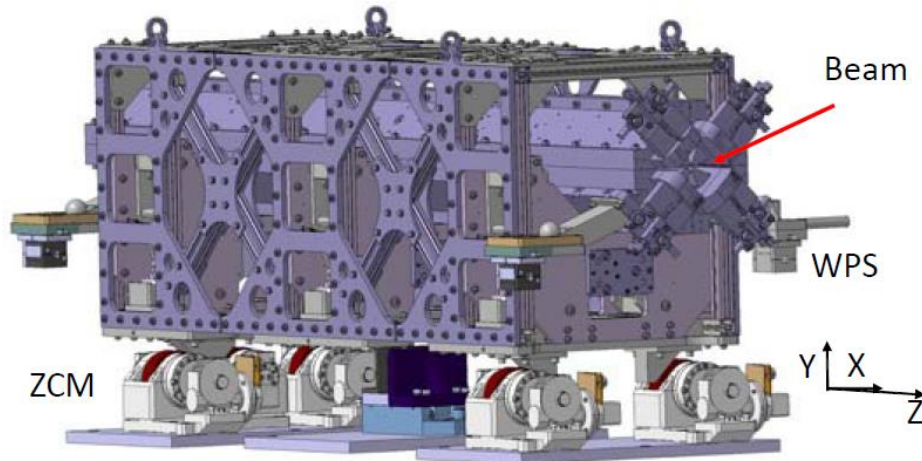

Type 4 MBQ and stabilization system mounted on cam movers (left) and test setup including ZCMs, follower girder and local coordinate system (right).

- CLIC type 4 MBQ together with a nano-stabilization system. The combination weighs 570 kg. It is mounted on five cam movers which control five degrees of freedom (DOF).
- Translation in the direction of beam is not controlled but blocked mechanically.
- In-house-developed predictive movement algorithm is used to calculate the controlled five DOFs

Maximum deviations of approximately $0.5 \mu\text{m}$ for x-offsets, $0.4 \mu\text{m}$ for y-offsets and $1.3 \mu\text{rad}$ for roll has been obtained

Active-positioning: System Control for the CLIC Main Beam Quadrupole Stabilization and Nano-Positioning

Spec.:

- Reduce the motion of quadrupoles (from 100 to 400 kg – type 1 and type 4)
- 100 μ rad maximum roll for MBQ
- 10 μ m range

stabilisation requirement vertical	$\sigma_y = 1.5 \text{ nm}$
stabilisation requirement horizontal	$\sigma_x = 5 \text{ nm}$
Repositioning step	10 nm
Repositioning frequency	every 20 ms
Repositioning precision	$\pm 1 \text{ nm}$
High radiation environment	300 Gy/year
Static stray magnetic fields of quadrupole	$0.15 \times 10^{-4} \text{ T at } 0 \text{ Hz}$

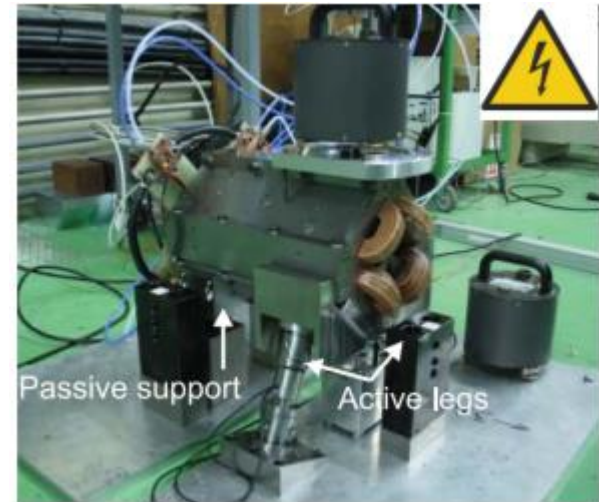

A Type 1 quadrupole magnet for CLIC on two active inclined piezo-electric actuators

Reduction of the vibration level from 6 nm to 0.45 nm integrated RMS at 1 Hz was achieved for a type 1 magnet, well under the requirements.

- The alignment tolerances of the FCC-ee accelerator elements can currently only be met by a monitoring and alignment system such as that proposed for the CLIC.
- The alignment tolerance on the dipoles are significantly lower than those of the quadrupoles, however, it is assumed that all beamline elements will be measured and aligned with the CLIC system.
- Given the lower alignment tolerances of the FCC-ee, the research and development of different monitoring and alignment system concepts need to be considered.

What about (dynamic) positioning ?

- Given the huge number of magnets and components needing positioning and the stringent alignment requirements, a dynamic positioning approach for girder seems judicious.
- A more precise and individual positioning of the elements like for CLIC magnet is possible but would need to be refined by optical simulations according to the tolerances.
- Dynamic positioning system should be considered in the vibration mitigation issues of the MDI working group

▪ Dynamic positioning



- From past to future accelerators dynamic positioning has always been a challenging subject.
- The feasibility of dynamic positioning has always been demonstrated for different accelerator requiring increasingly stringent requirement.

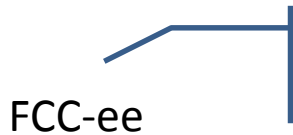

No clear dynamic positioning strategy defined yet.

▪ Opportunities

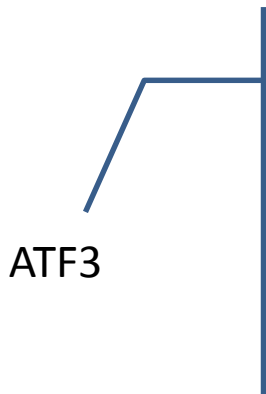

- The next Accelerator Test Facility (ATF3) is under way. This should be considered as an opportunity to
 - Upgrade the existing positioning strategy of ATF2 final focus to solve the current vibration issues
- Or
 - Define a dynamic positioning strategy applied on the concerned components and test it with ATF3 final focus