

# CERN ISOLDE AND REX BEAM INSTRUMENTATION

G. J. Focker, CERN, Geneva, Switzerland

## Abstract

An overview is given of the Instrumentation at Isolde, an on-line mass separator that gets its protons from the PS Booster at CERN. One of Isolde's beam-lines now feeds isotopes to a 3MeV post-accelerator, called Rex. For Isolde the Instrumentation consists mainly of wire scanners, Faraday-cups and wire grids, but Isolde couldn't operate without a tape-station. Rex is equipped with Instrumentation boxes containing a collimator, a Faraday-cup and an imaging system. Some additional equipment is proposed.

## INTRODUCTION

The ISOLDE on-line mass separator facility at CERN is mainly used for the production of pure samples of short-lived radioactive isotopes. It consists of two electromagnetic isotope separators, the General Purpose Separator (GPS) and the High Resolution Separator (HRS). One of the beam lines connects to Rex, a post-accelerator of 3MeV.

The radioactive nuclides are produced in a suitable target bombarded with the high intensity beam of 1GeV or 1,4GeV protons from the PS-Booster. The PS-Booster can deliver a beam-current up to  $2\mu\text{A}$ . After ionisation and acceleration up to 60keV, the ions are mass analysed. The selected beam from either of the two separators is then fed into a beam transport system and steered to the experiments, or to Rex.

The aim of the beam instrumentation is to obtain information on intensity and profile of the low intensity ( $<10\mu\text{A}$ ) d.c. ion beams all along the beam path. In the design of the ISOLDE mass separators attention was paid to provide access for beam observation at the most critical regions such as the entrance to the magnets and the different focal points. However, if one wants to introduce several probes and a slit in a given position the available space along the beam axis may be limited, in particular if the focusing is strong. Therefore they need to be compact in the direction of the beam. In addition, emphasis was put on the probes to be easily interchangeable and sufficiently radiation resistant because of the radioactive environment in which they have to operate.

For Isolde the beam detection is based on the deposition of electrical charge from the beam on a probe. Unless suppressed, the emission of secondary electrons enhances the measured current by a factor depending on the surface conditions and the species and charge of ions collected. Different are the Tape-stations with which radioactive particles can be detected by measuring their decay-products.

Rex uses an imaging device based on the secondary electron emission of the beam on a metal foil.

## ISOLDE AND REX

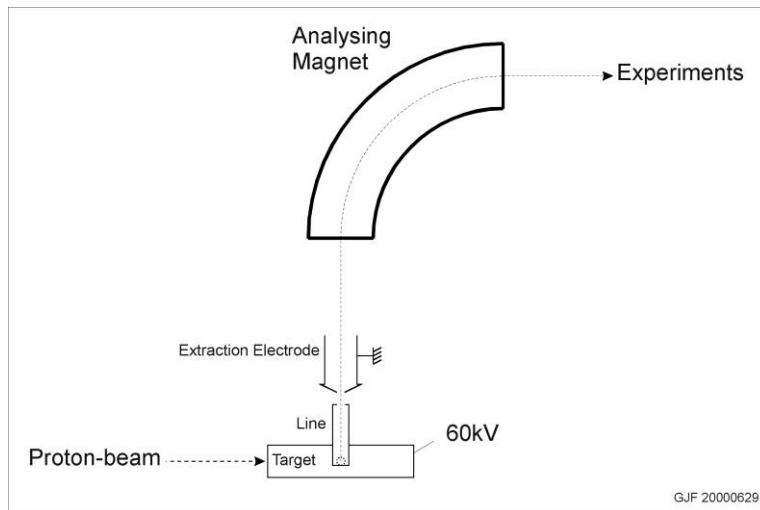

## The Isolde Separators

The General Purpose Separator (GPS) uses one analysing magnet; the High Resolution Separator (HRS) uses two. Until now more than 600 isotopes of more than 60 elements ( $Z=2$  to 88) have been produced with half-lives down to milliseconds. Both machines use the same types of targets, which exist in several different configurations. The exchangeable targets have a heated container filled with the material to be radiated from which the resulting isotopes are extracted and ionised in the very hot "line". Normally the resulting charge per ion is +1, but Isolde can also be switched over to work with negative ions. This complete target-unit is held at a potential of 60kV, or lower if requested by experiments. The targets are exchanged with robots. With the high voltage between target-unit and the extraction electrode the ions are accelerated after which the wished mass is selected with the high precision analysing magnet.

The HRS now has an RFQ to cool the beam, designed at Jyvaskyla.

The ion-beam intensities after the analysing magnets will typically be up to  $10^{11}$  particles per second, but may be as low as a few particles per second and may exceptionally be higher, especially before the analysing magnets.

The GPS has three beamlines. Two beamlines can directly be used for experiments; the third beamline joins the HRS in a merging switchyard. From here the whole network of beamlines in the Isolde hall is fed, including Rex.

### The Rex Post-accelerator.

Rex can only function with a pure beam such as provided by the HRS. First ions are trapped in a Penning-trap, then transported to “EBIS”, which is a charge-breeder. From there they are again mass-analysed and then accelerated up to 3MeV.

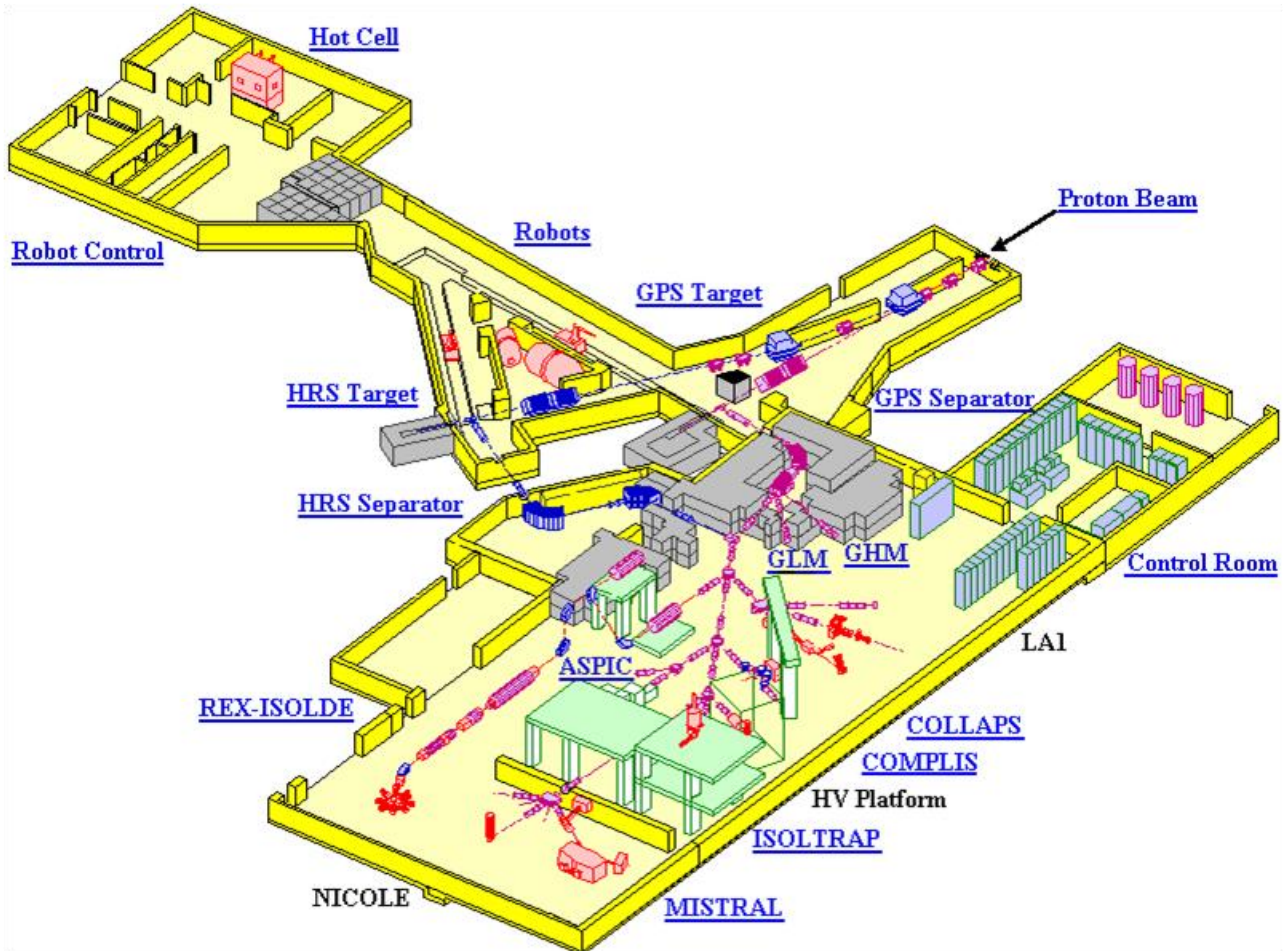
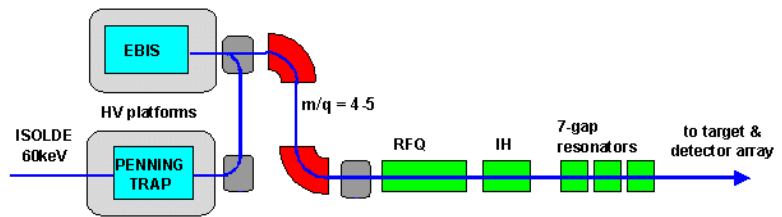

## THE ISOLDE INSTRUMENTATION

### Overview.

The Isolde instrumentation consists of Wire-scanners, Wire-grids, a “Fixed Needle Beam Scanner”, Faraday-cups and Tape-stations.

### The Moving Wire-scanners.

The development of the Wire-scanners was started in the early 1980’s by G. Sidenius and A. Lindahl at the Niels Bohr Institute in Copenhagen and since then it has been further improved at CERN. The pick-up needle is mounted on a small chariot which also carries the pre-amplifier. It is guided on a rail and driven back and forth by a stepping motor via a 0.1mm thick piano wire. There is only one position-reference and only one direction is used for data-taking to avoid the effect of mechanical hysteresis.

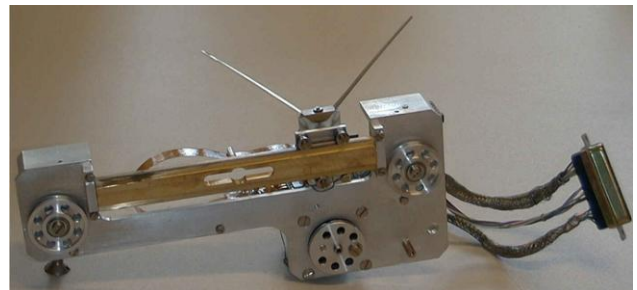

Most scanners at Isolde are x/y scanners. Equipped with a V-shaped pick-up (angle of 90°) the scanner chariot moves at 45° with respect to the horizontal plane thus producing both an x- and a y-scan of the beam profile. Originally equipped with pick-ups from Danfysik the pick-ups are now progressively being replaced by needles of material like that being used for medical syringes. The

stroke-length of these scanners is 97mm, which due to the 45° angle results in an effective length of 69mm.

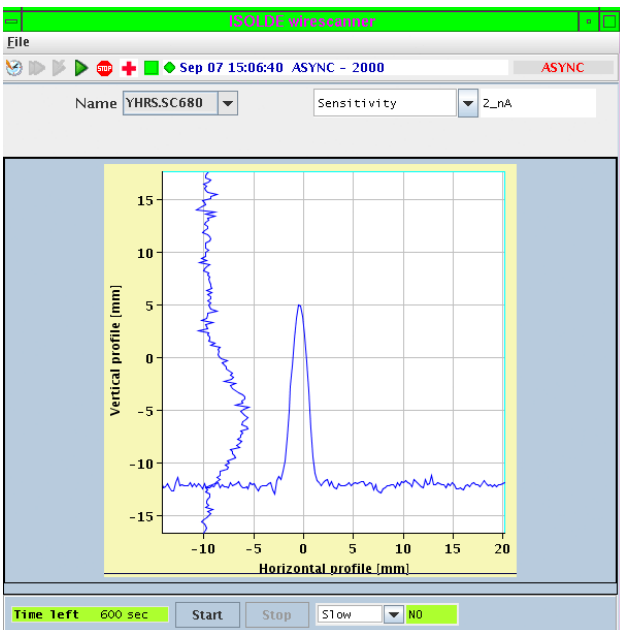
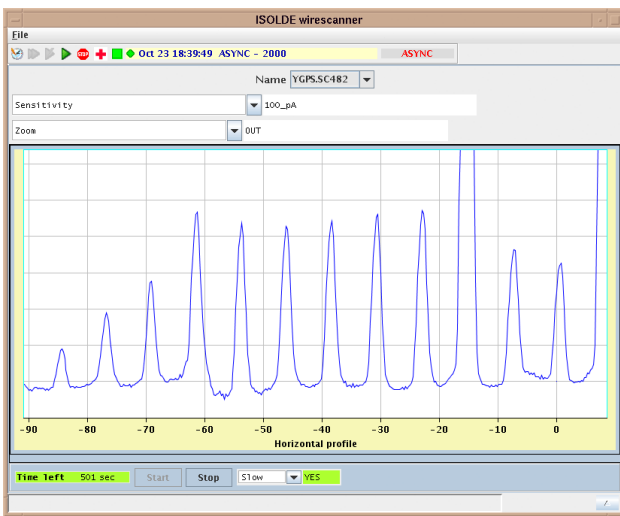
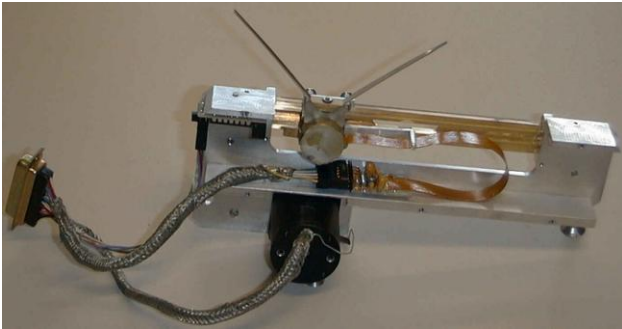

There is one horizontal scanner with a stroke-length of 97mm and there are four horizontal scanners with a stroke-length of 182mm. All these horizontal scanners are mounted in areas with higher radiation, therefore the 182mm scanners are mounted in pairs for redundancy and

the 97mm is mounted close to a wire-grid, where must be remarked that the resolution of the scanner is so much higher than the grid's that the operators felt quite lost when the scanner was temporarily out of service.

The maximum electrical input current of the scanners is 20µA full scale, the lowest current range is 25pA. The scanners can move at speeds of 1m/s. they are normally used with 200mm/s while taking data and up to 800mm/s to return to its origin position. For high sensitivity (200pA or less) both the bandwidth of the amplifier and the scanning speed are reduced.

### Wire-grids.

Wire-grids are used in those areas close to the targets where the radiation levels are too high for the scanners with their incorporated electronics. Five grids have wire-spacing's ranging from 1,25mm to 2,5mm and cover area's of 75 by 75mm. Then there are two grids of 20 horizontal wires with a wire-spacing of 1mm, combined with a fixed slit and a hole. The grids are moved in and out pneumatically.

The electrical sensitivity ranges from 20pA full scale to 2mA. The latter was defined in a time that high output targets were expected. Until yet the study about how much energy the wires would be able to stand has not yet been started, but it seems unlikely that they would survive and luckily such targets were never constructed at Isolde (yet). For the highest sensitivities the system uses an integration time of 1 second.

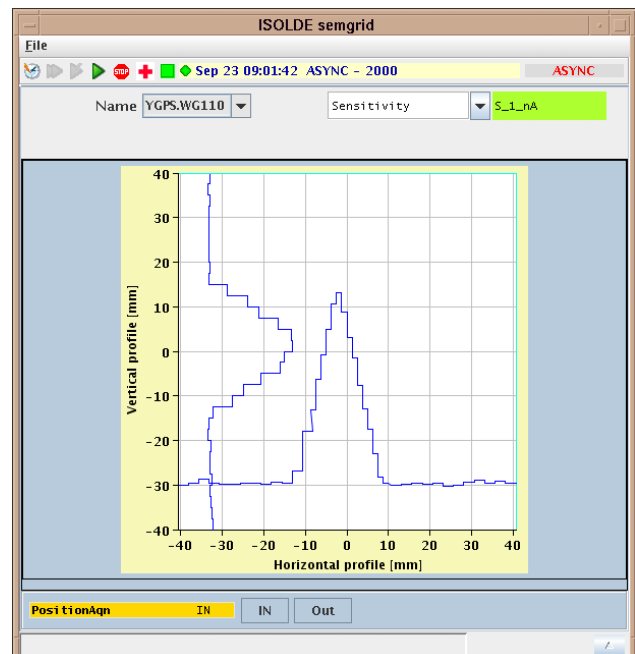

### Faraday-cups.

Faraday-cups are used everywhere at the separators, the beamlines and Rex. Both GPS and HRS Frontends each have one large Faraday-cup. The latest design for the new Isolde Frontend has an opening of 75mm. This Faraday-cup is prepared for water-cooling so that it would stand a



beam of 2mA. As for now such beams don't exist at Isolde the water-cooling will not yet be used.

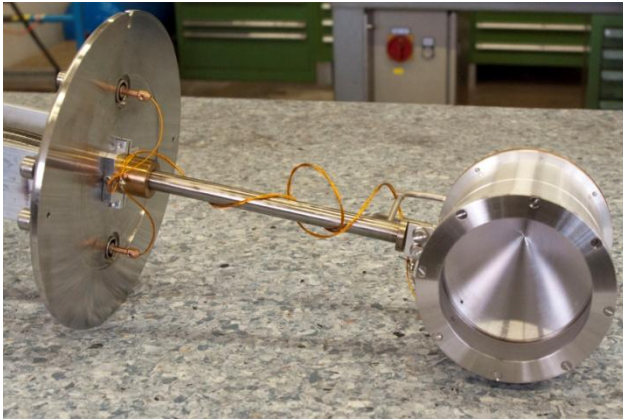

All other Faraday-cups have an opening of 25mm. Isolde counts 32 Faraday-cups and at the moment 9 are installed at Rex. Many of the 25mm Faraday-cups are

mounted on a flange together with an x/y scanner and form the standard instrumentation device used at Isolde.



The repeller voltages used for the Faraday-cups vary from 130V for the small ones to 250V for the large ones.

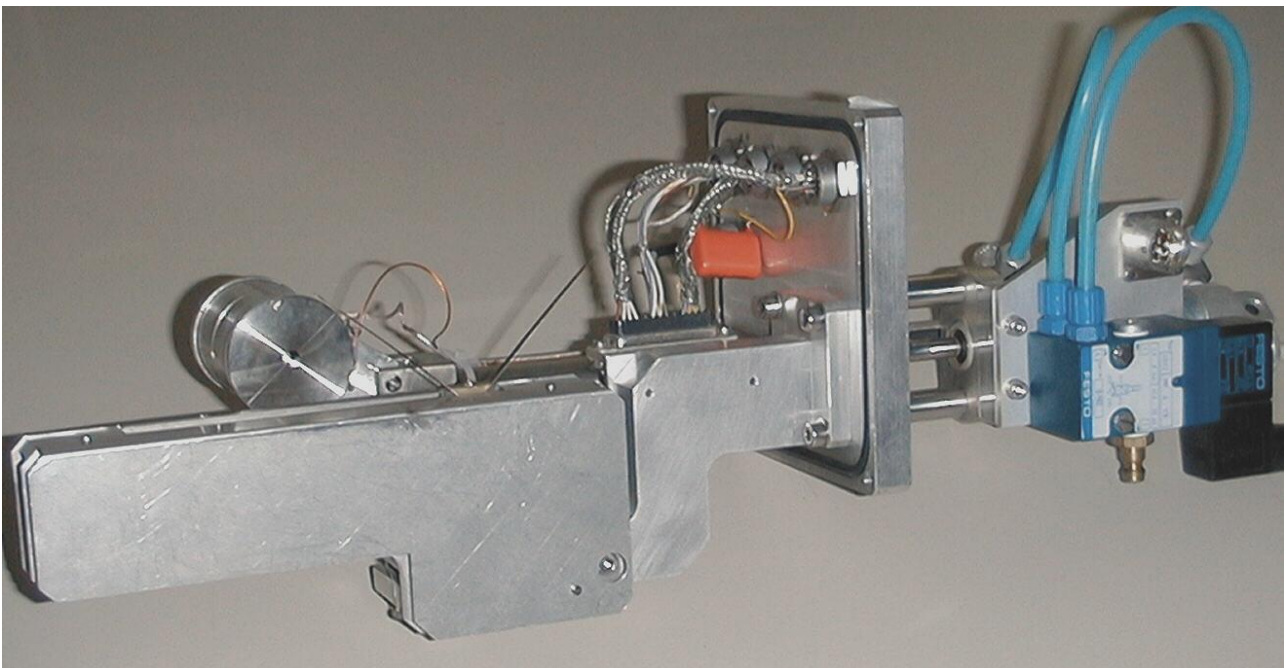

The readout of the Faraday-cups is done with Keithley electrometers and multiplexers. Though the Keithley devices themselves are very good, they can function properly only in electrically very clean environments. At Isolde the cables are too long, not of the best materials and pulled along all other cables, thus causing a background level of sometimes up to 2pA. At Rex the situation is better and noise-levels allow to measure down to 0,5pA. But at Rex the beam is pulsed, which the Keithleys can handle at very low input-currents, but not at more than 1nA. A special device has now been developed and is actually being tested at Rex-Trap. This device, called "PicoAmpèreMeter" or "PAM", solves the different problems by integrating over longer periods. The sensitivity of the "PAM" is not very special, in practice it allows to

measure down to 0,2pA. The integration time is programmable from 200ms to 1s. The device is small, mounted close to the Faraday-cup and also contains a miniature power supply for the repeller voltage and can control the pneumatic movement of the Faraday-cup. It is controlled via Profibus.

### *The "Fixed Needle Beam Scanner".*

Problems with the Isolde wire-scanner are the vibrations of the mechanical movement causing electrical noise, the "inaccuracy" of the mechanics (even if that is smaller than 0,2mm) and the relative thickness of the pickup or needle. The "Fixed Needle Beam Scanner" (FNBS) is meant to provide more accurate measurements. The needle is replaced by a wire of 0,05mm and the mechanical movement is replaced by an electrostatic devia-

tion of the beam. The only mechanical movement remaining is the possibility to move the wire in and out the beam with a pneumatic movement. The maximum deviation of the beam is  $\pm 9,8\text{mm}$ , usually a deviation of maximum  $\pm 5\text{mm}$  is chosen. Though the FNBS deviates the beam it doesn't quite stop the beam, but while it is active the beam will be distorted after the next focussing element. The FNBS is situated after the second analysing magnet of the HRS.

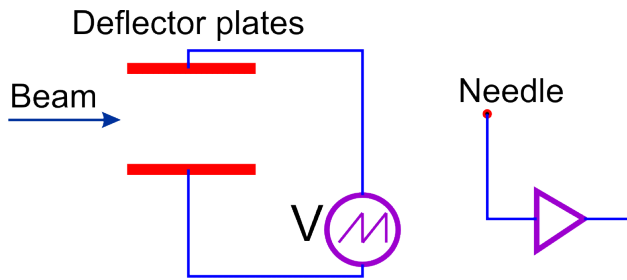

### The Isolde Tape-stations.

A Tape-station allows to measure radioactive particles even if they cannot be seen by other beam instrumentation. The Tape-stations are used to:

- Optimise target and ion-source,
- Optimise the position of the proton-beam
- Measure half-lives of isotopes by using a Multi-Channel-Analyser. The latter now is part of the latest application program.

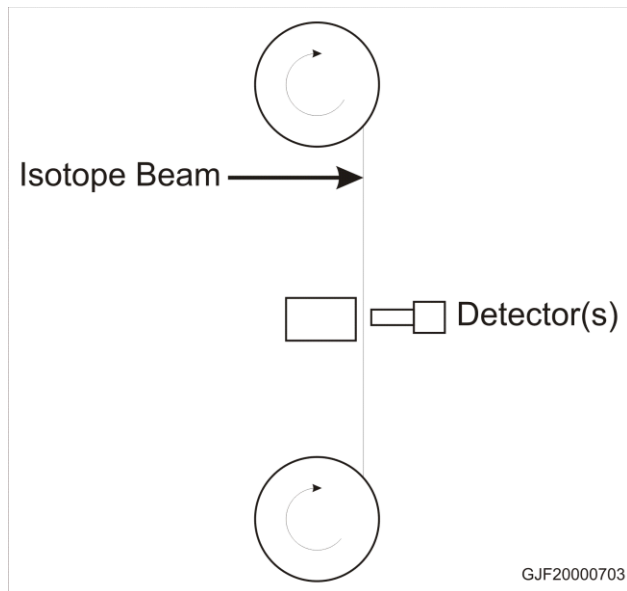

A Tape-station is very important at Isolde. Without it target and ion-source cannot be optimised which is equivalent to closing down the machine.

Important parts of the Tape-station are the timing and a good working beamgate. The beamgate will usually be closer to the target or at a spot that is suitable to dump the beam. The first step is to collect particles onto the tape. This collection may take place during a few milliseconds

up to seconds, it may be triggered by the arrival of a proton-beam pulse, or delayed, or be triggered by an experiment. After the collection the tape is moved as rapidly as possible to the detector(s), usually a scintillator and photomultiplier. While the detector(s) are counting a new collection may be made to gain time, allowing a series of measurements to be made to measure e.g. the release curve of the target.

Isolde temporarily has two Tape-stations. The old one shall be removed when the new one is ready to take its place.

The original designs of the old Tape-station date from 1974. Though the mechanics are somewhat more recent, the electronics date from 1978 and were often modified. Though it runs better than ever this system isn't very reliable.

A new Tape-station has been developed by Philippe Dessagne and his collaborators at the IPHC (previously IRES) at Strasbourg. Modern, much more powerful and faster, this system will replace the old Tape-station once it has passed testing

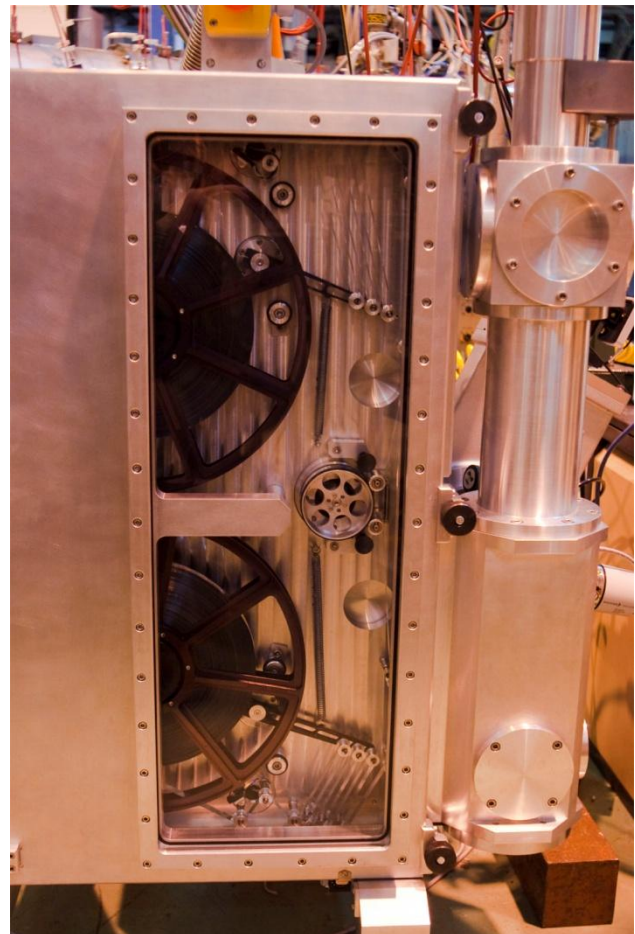



## REX INSTRUMENTATION

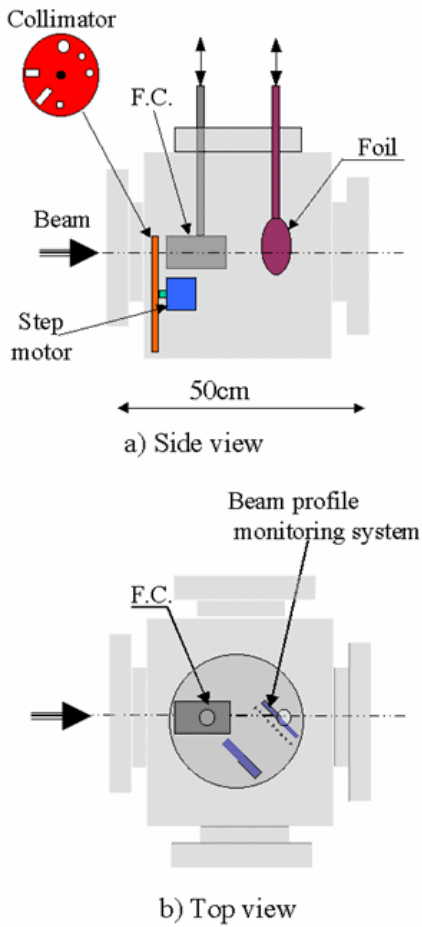

The Rex Instrumentation Box has been designed and manufactured by the Leuven University. At the moment 9

boxes are installed. Each box contains:

- A collimator,
- A 25mm Faraday-cup,
- An imaging system.

The collimator is a metal disc that can be rotated with a stepping motor. The disc has ten positions with different slits and holes and occasionally is used to insert filters in the beam.

The imaging system is made with a metal foil placed in the beam at an angle of 45°. The secondary electrons are attracted by a close by mounted grid and travel to a MultiChannelPlate that is placed away from the beam. The amplified signals end at a phosphor screen that is filmed at again an angle of 45° by a CCD-camera.

A special case is where the foil is also used to measure currents directly. This setup is used at Rex-Trap for Time-of-Flight measurements.

## SPECIAL INSTRUMENTATION

Special instrumentation that is used occasionally and is not connected to the control system.

*The "Fast Faraday-cup".*

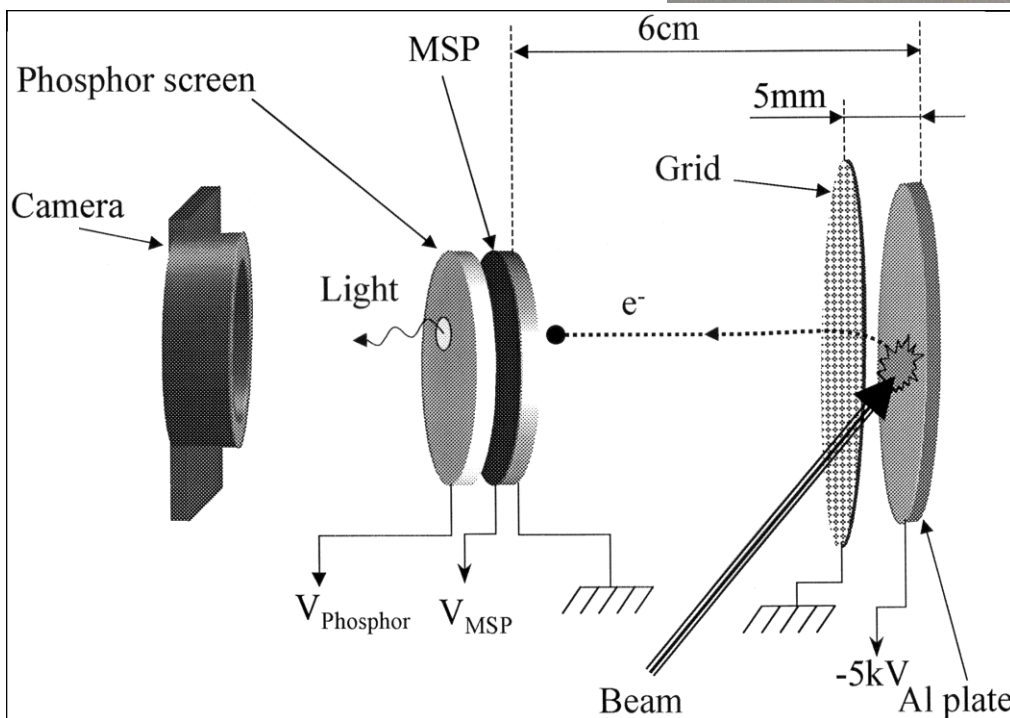
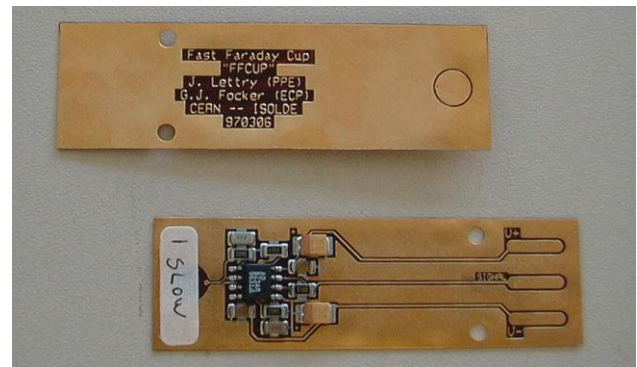

What is called the "Fast Faraday-cup" isn't a Faraday-cup really, but merely a collector-plate as the repeller electrode is missing. It is made on a thin Kapton PCB, on one side the pickup electrode is situated and on the other side the electronics. The PCB is placed in a small brass housing that is moved in and out manually. The output connects to an oscilloscope. The bandwidth depends on the chosen amplification and can be up to 10MHz. The device was made in 1997; by

simply replacing the operational amplifier by a more modern type it should be possible to increase the bandwidth and/or the input sensitivity.

### *The NTG Emittance meter.*

The NTG Emittance meter uses moveable slits, one vertical and one horizontal, and wire-grids. Though it is an enormous device, it is moved around everywhere to check any new or modified installation. Hence it is not permanently installed but yet quite regularly used.



## CONCLUSION

Designing the Isolde Beam Instrumentation (mainly by E. Kugler, now retired) had as goal to make a user-friendly system, and relatively easy to repair. Though the standard scanner/Faraday-cup unit is easy to replace, the horizontal scanners are not, though rather due to the radiation levels. The scanners are very sensitive equipment and many make many more scans than what they were designed for. But the ones that are well-made seem to keep forever and the past years a lot of effort has been put in improving those that kept breaking down. Since last year's experience one may now carefully say that the effort carries its fruits, no mechanical problem has occurred.

The system could always be improved by increasing the sensitivity of the detectors. But then this is rather an environmental problem than a limitation of the electronics.

A device that is missing in the Isolde instrumentation is a small Allison scanner (a compact emittance-meter) like used at Triumf in Vancouver. Such a device could stay permanently in the machine and in places where the NTG cannot be installed, like for instance between the two analysing magnets of the HRS. A project was started, but does not advance at this moment.

I'd like to thank Thierry Stora and Erwin Siesling (both CERN) for their information helping me to write this document.

## REFERENCES

[1] G. J. Focker, F. Hoekemeijer, O.C. Jonsson, E. Kugler, H. L. Ravn, CERN, Geneva, Switzerland, "The Beam Observation System of the ISOLDE Fa-

cility", BIW94, Vancouver, 2-6 October 1994. AIP-proceedings Vol. 333, p. 196  
[2] G. J. Focker, E. Bravin, S. Bart Pedersen, CERN, Geneva, Switzerland, "The Renovation Of The Isolde Instrumentation", DIPAC'95, Lyon, June 2005, [http://accelconf.web.cern.ch/AccelConf/d05/PAPER\\_S/POW003.PDF](http://accelconf.web.cern.ch/AccelConf/d05/PAPER_S/POW003.PDF).  
[3] E. Kugler, D. Fiander, B. Jonson, A. Przewloka, H. L. Ravn, D. J. Simon, K. Zimmer and the ISOLDE Collaboration, "The new CERN-ISOLDE on-line mass-separator facility at the PS-Booster," Nucl. Instr. and Meth. **B70**, 41-49 (1992).