

# *The Coca-Cola Cavity*



# A simple coke can...

- A typical 330 ml coke can, resembles a cylindrical cavity.
- Field solutions can be found analytically with the correct boundary conditions.
  - TM and TE modes (see lecture notes)
- TM<sub>010</sub> – accelerating mode.
  - Resonant frequency given by:

$$f = \frac{c \cdot x_1}{\pi D}$$

- c – speed of light
- D – diameter
- x<sub>1</sub> – 2.40483

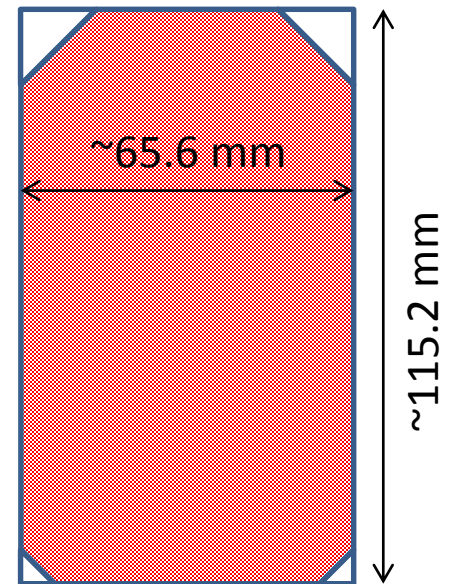

f=~3.5 GHz

# 2D Model

- Model A
- Superfish
  - 2D cylindrical symmetry assumed.

Geometry

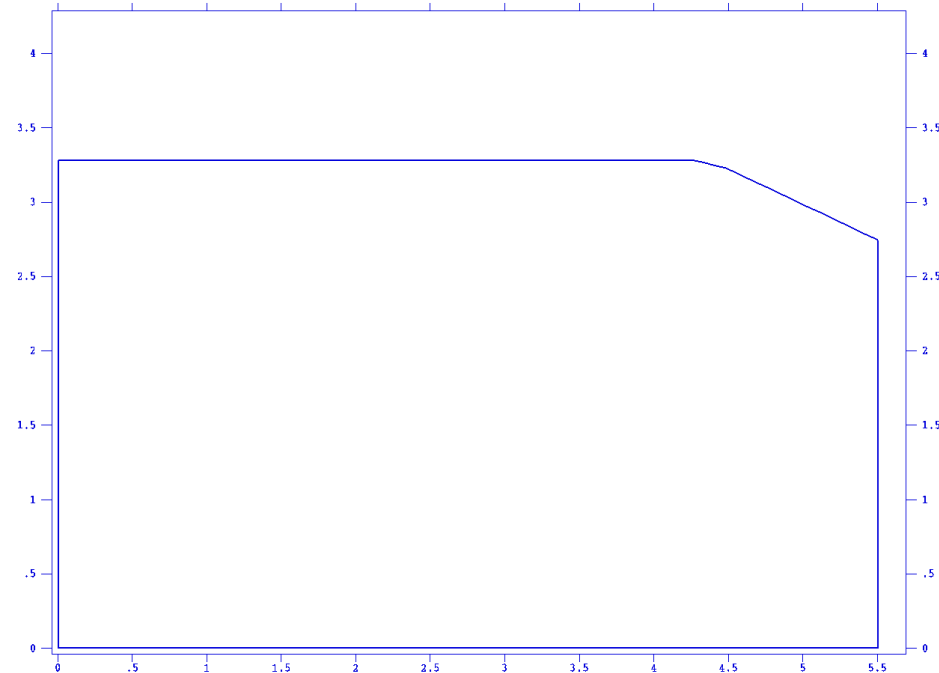

Mesh

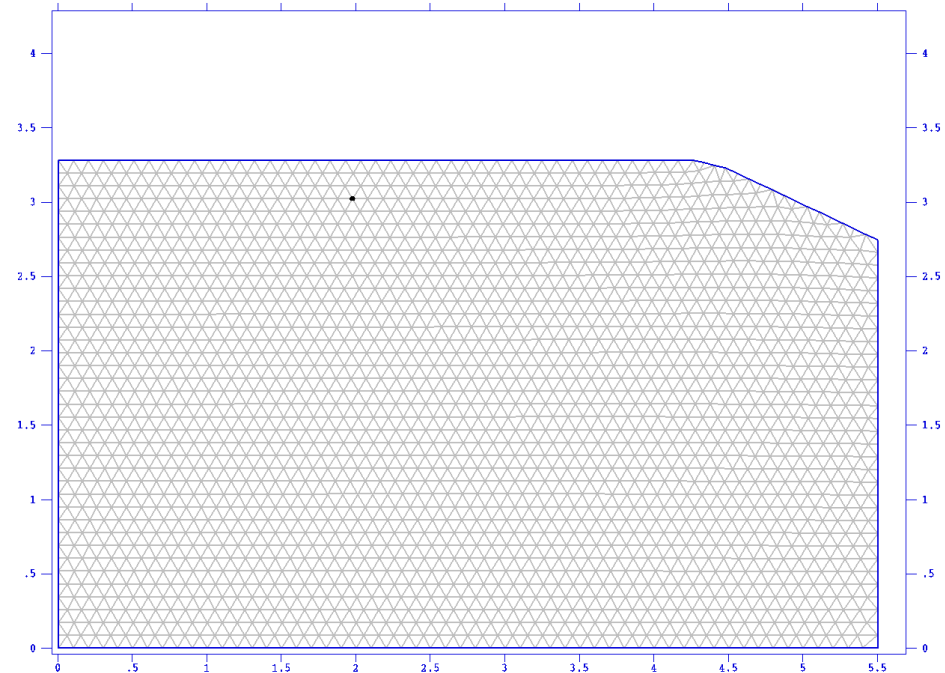

# 2D Model

- Model A
- Superfish
- Field normalisation: 1J stored energy/cavity

$f \approx 3.548$  GHz

Field Lines

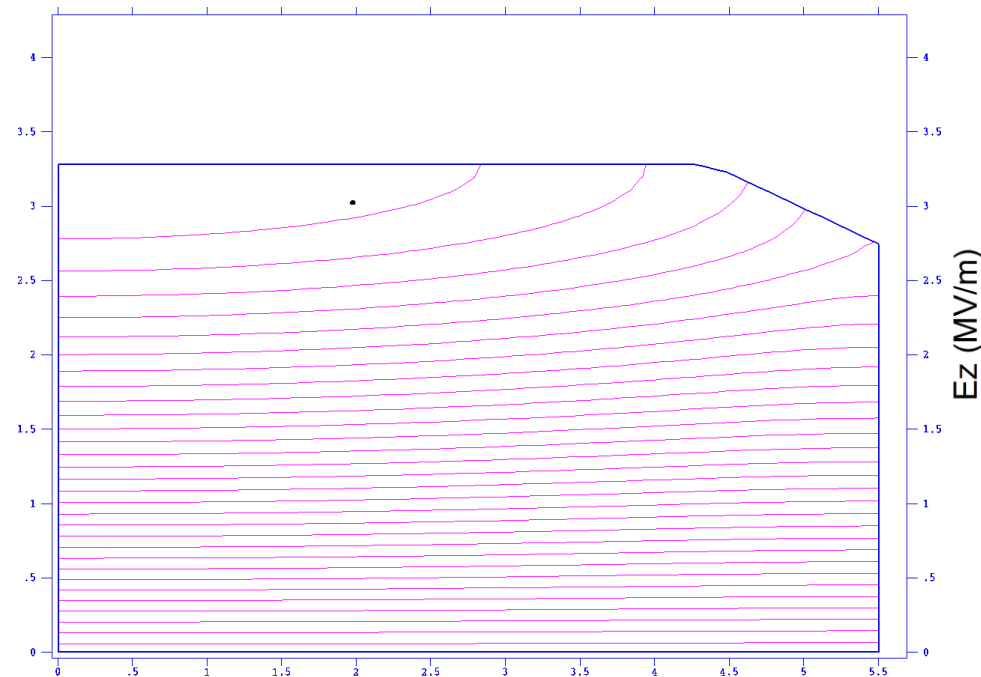

1D Field Line ( $E_z$  on axis – full can)

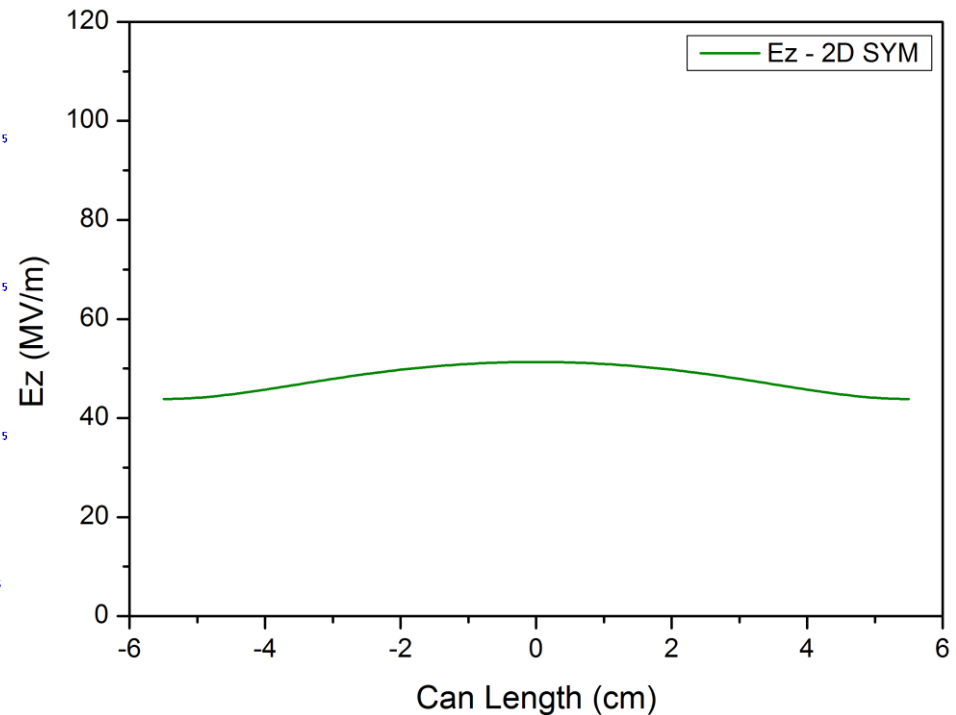

# 3D Model

- Model B
- CST MicroWave Studio
- Symmetric (like the 2D model)

Geometry

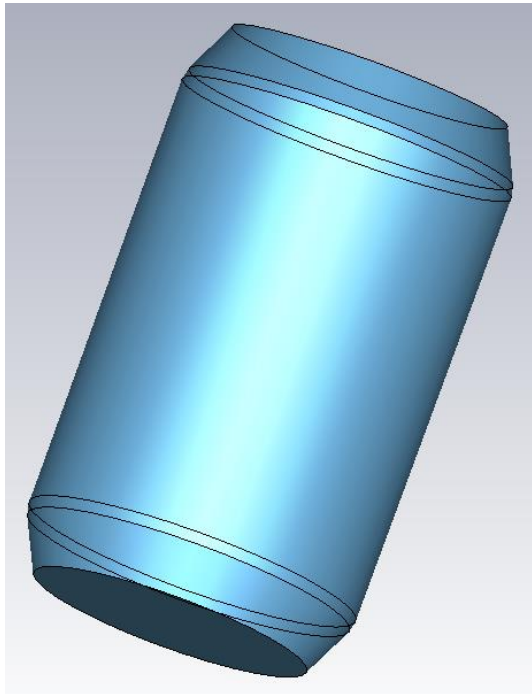

Mesh

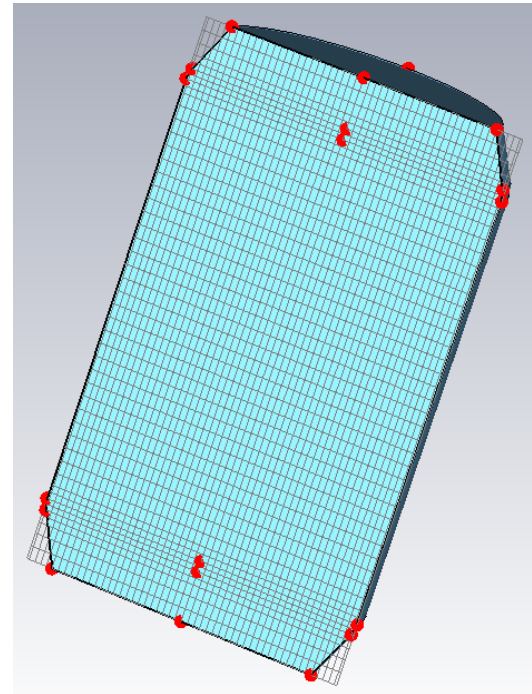

# 3D Model

- Model B
- CST MicroWave Studio

$f \approx 3.549$  GHz

Electric Field

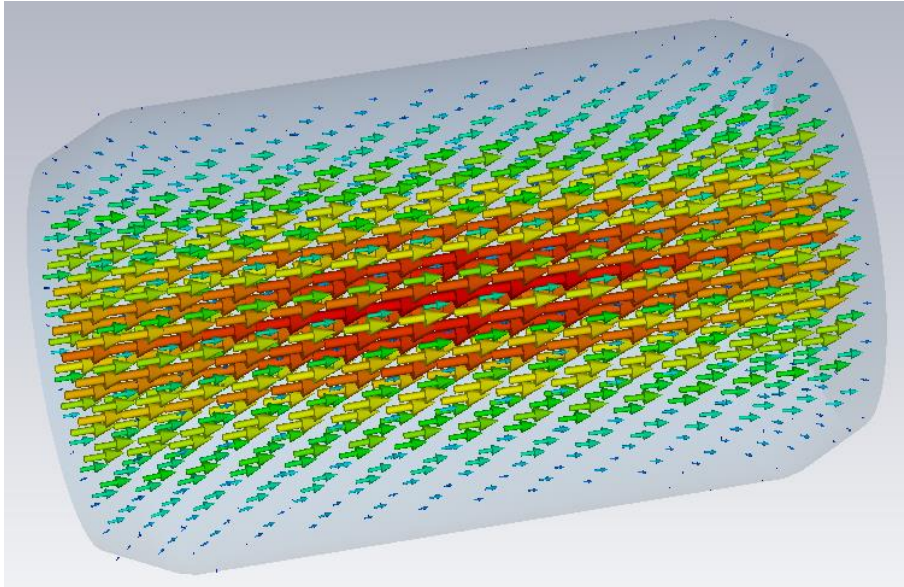

Magnetic Field

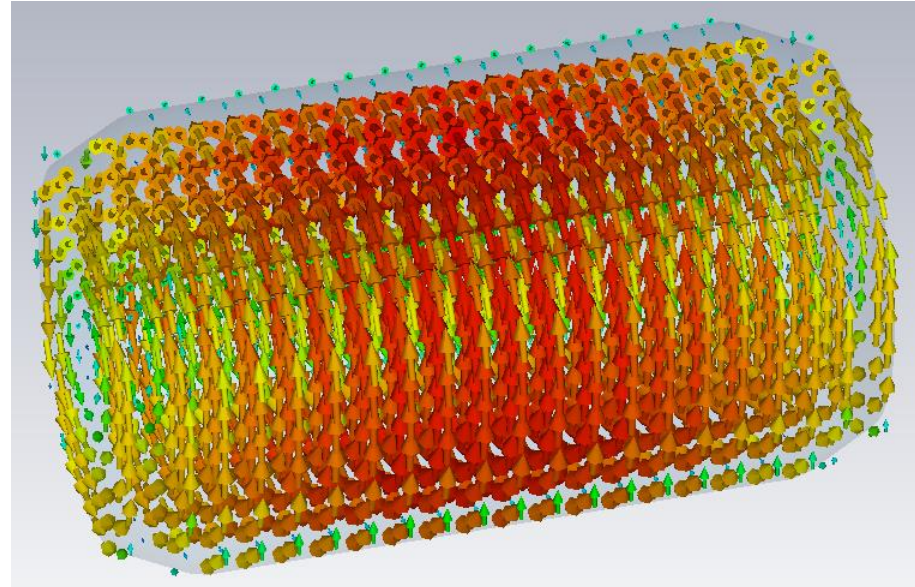

# 3D Model

- Model B
- CST MicroWave Studio
  - Field Normalisation: 1J stored energy/cavity

1D Field Map (Ez on axis)

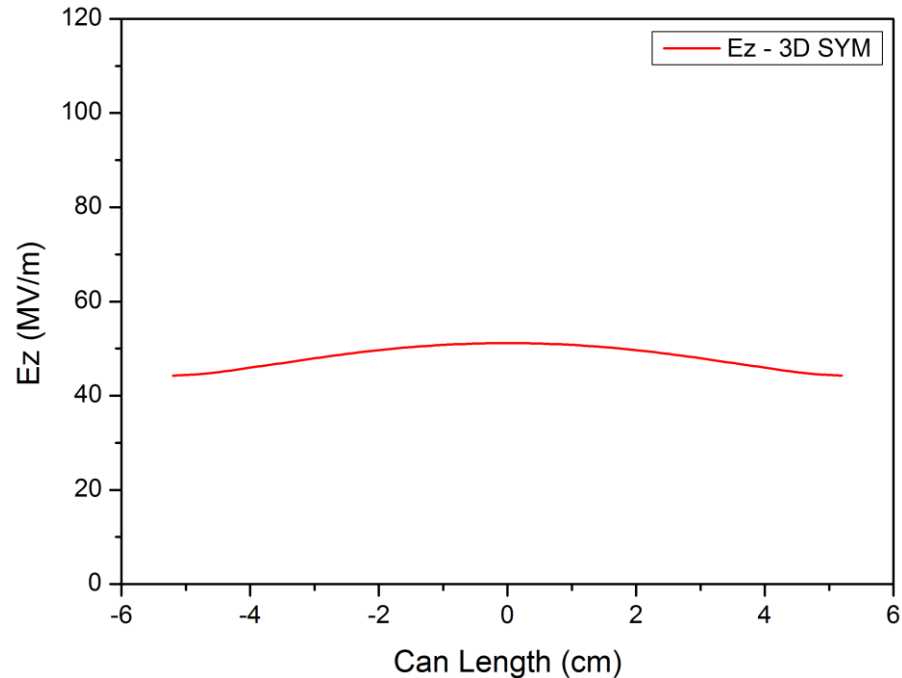

Comparison with the 2D Superfish result

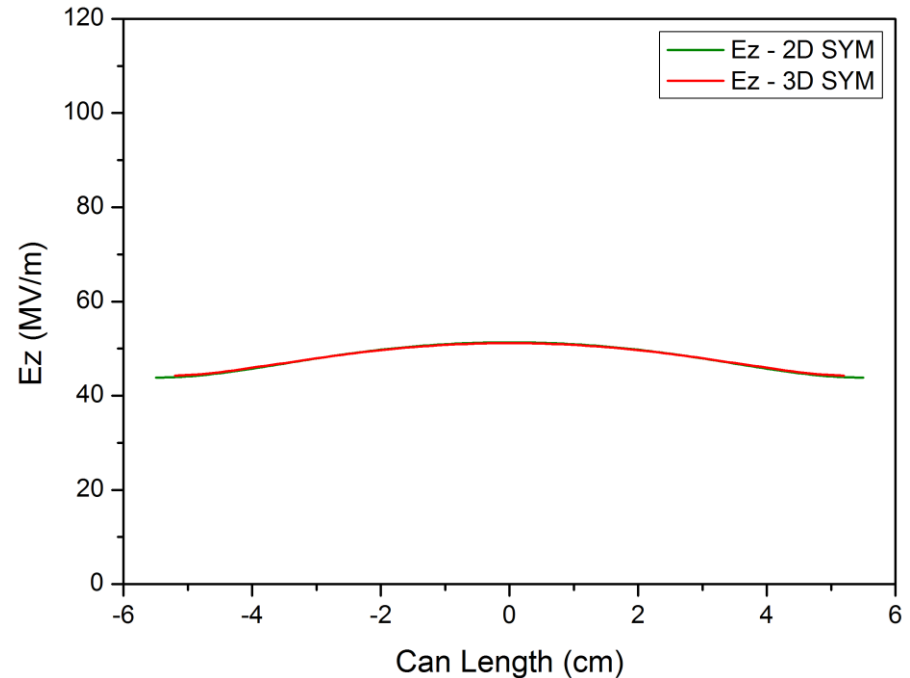

# 3D Model

- Model C
- CST MicroWave Studio
- Asymmetric (closer to an actual coke can geometry)

Geometry

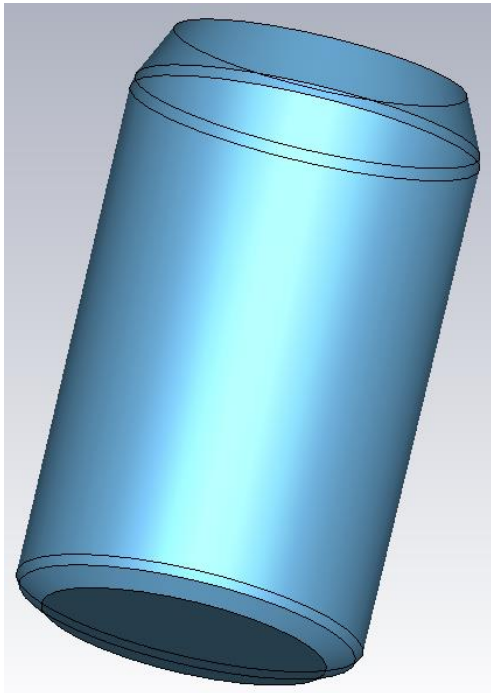

Mesh

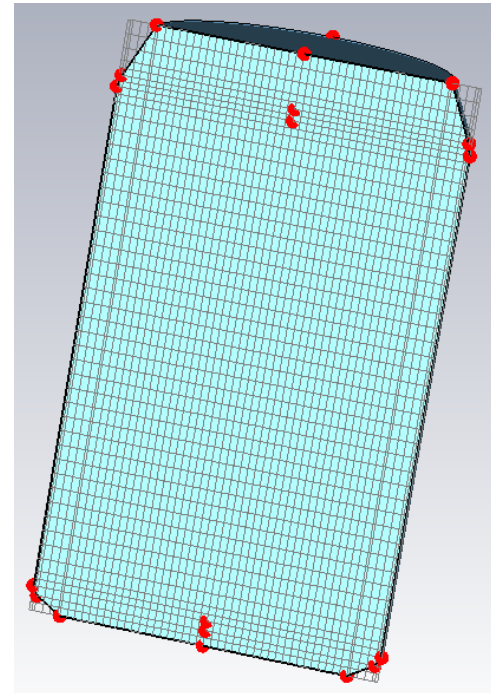



# 3D Model

- Model C
- CST MicroWave Studio
  - Different scaling

$f \approx 3.531$  GHz

Electric Field

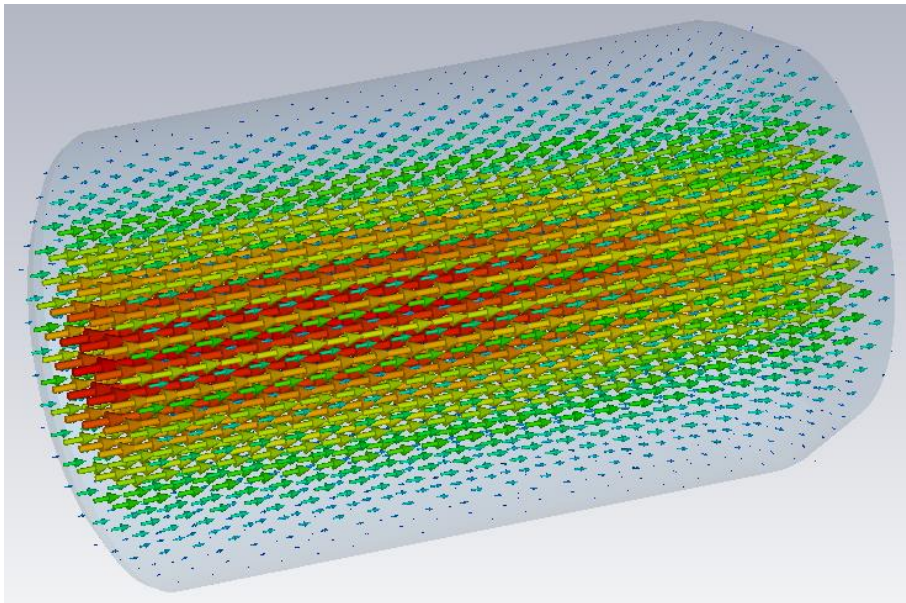

Magnetic Field

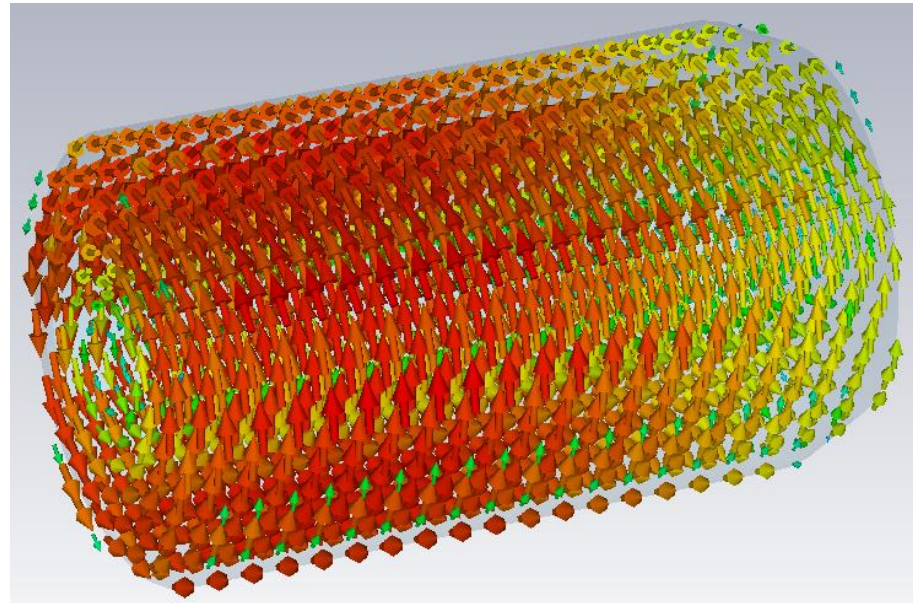

# 3D Model

- Model C
- CST MicroWave Studio
  - Field Normalisation: 1J stored energy/cavity

1D Field Map (Ez on axis)

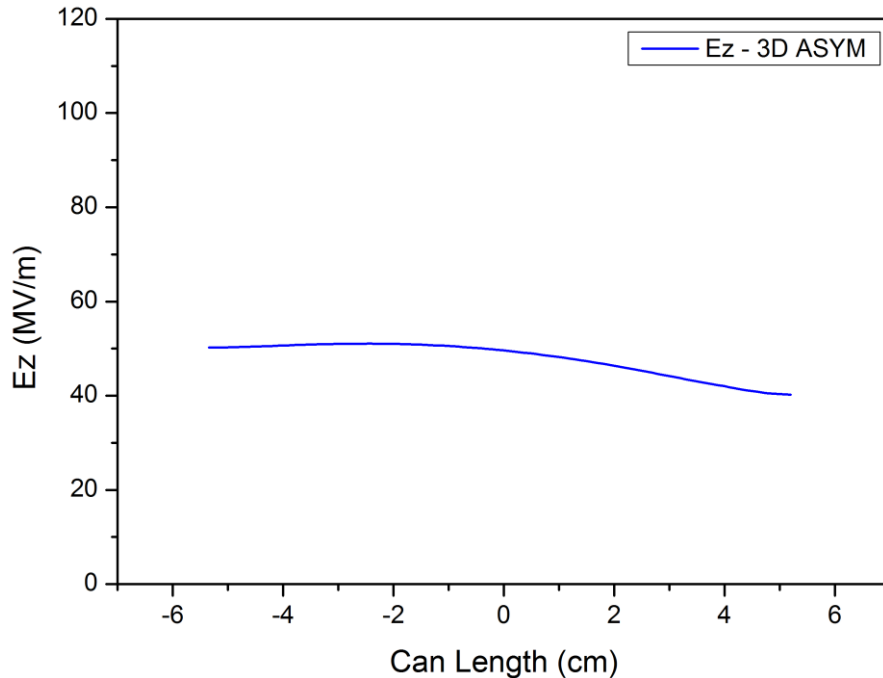

Comparisons...

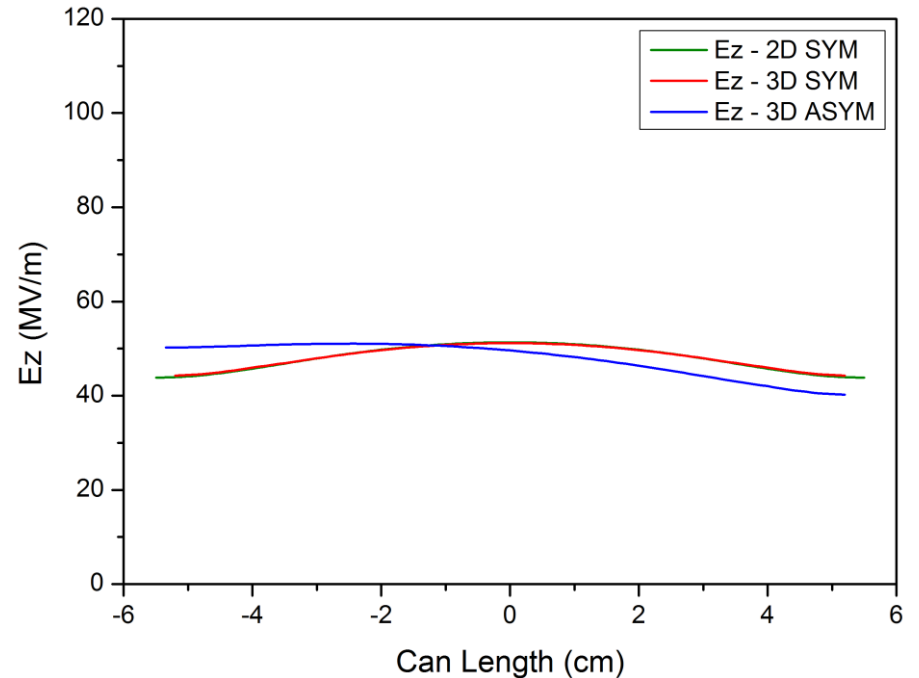

# 3D Model

- Model D
- CST MicroWave Studio
- Most Details (curves, corners, etc)

Geometry

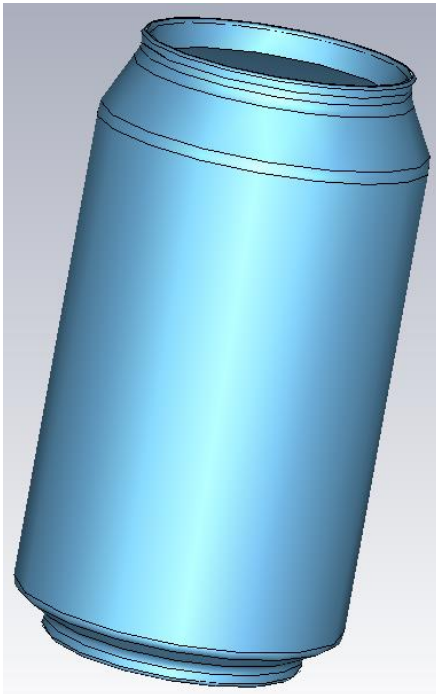

Mesh

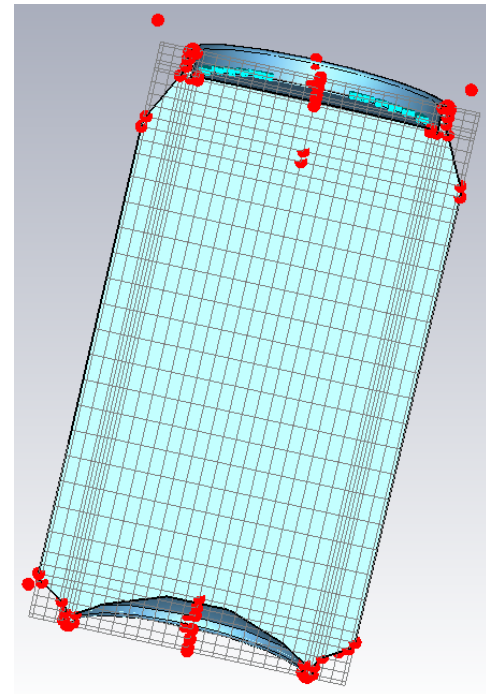

# 3D Model

- Model D
- CST MicroWave Studio
  - Different scaling

$f \sim 3.398$  GHz

Electric Field

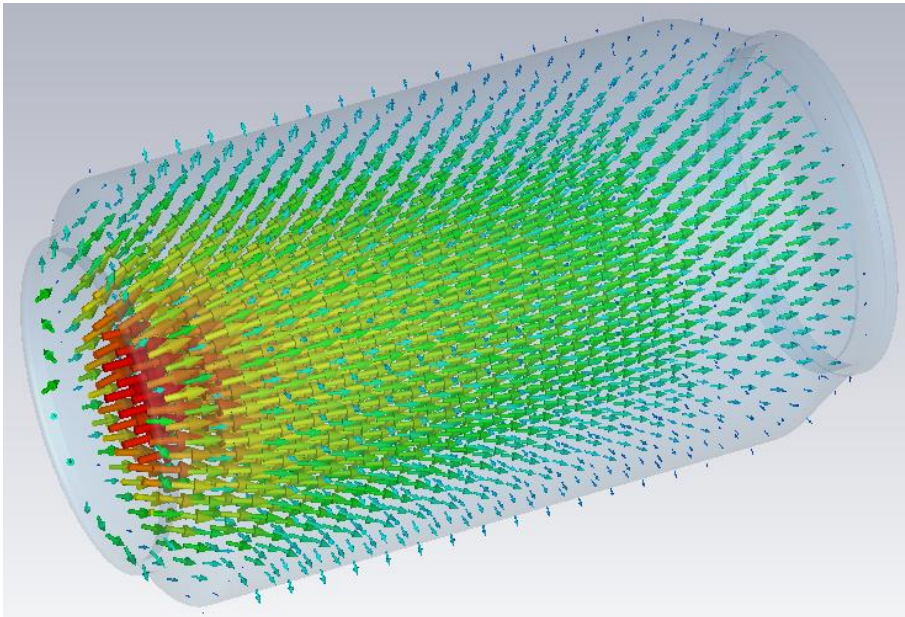

Magnetic Field

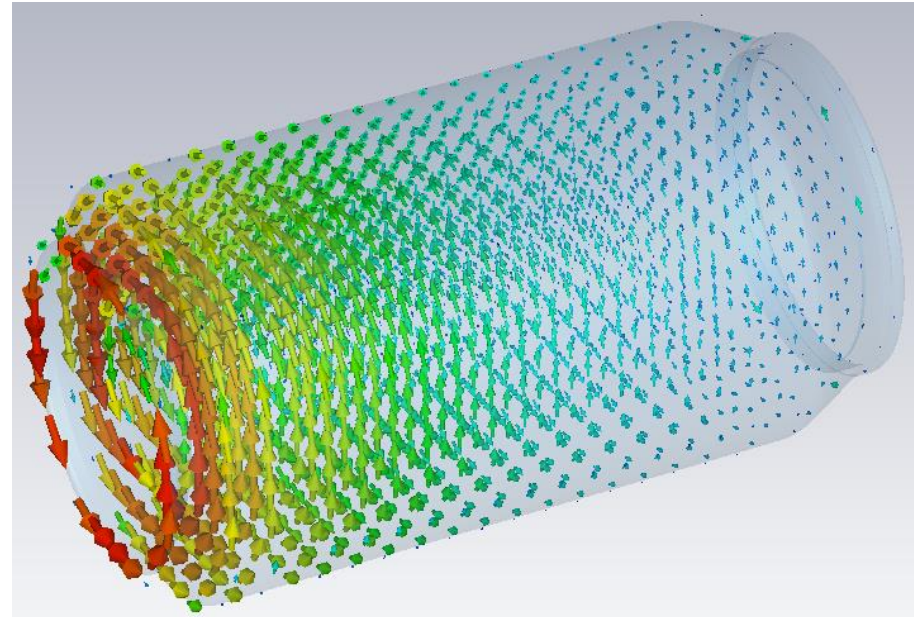

# 3D Model

- Model D
- CST MicroWave Studio
  - Field Normalisation: 1J stored energy/cavity

1D Field Map (Ez on axis)

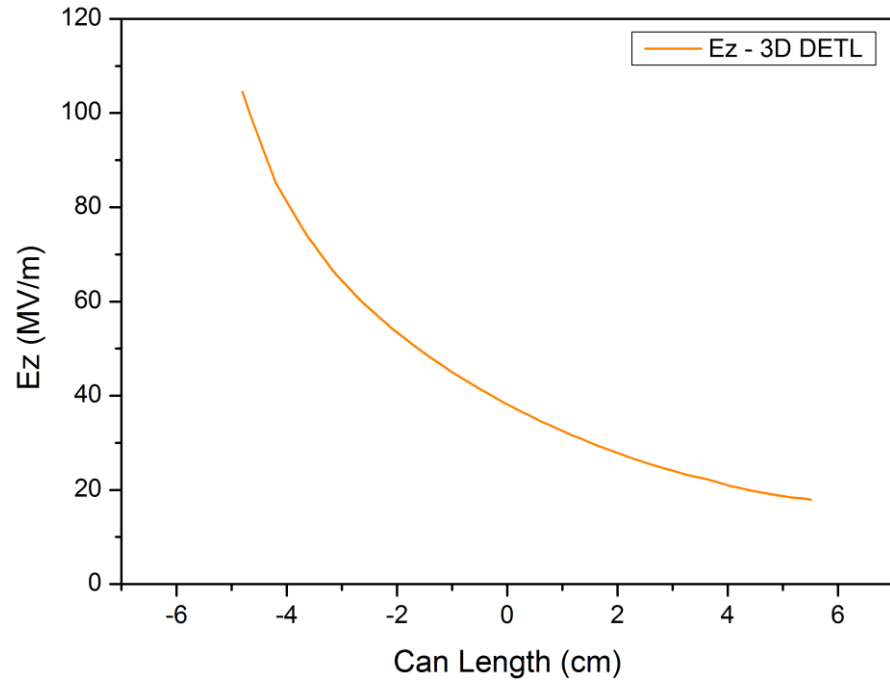

Comparisons...

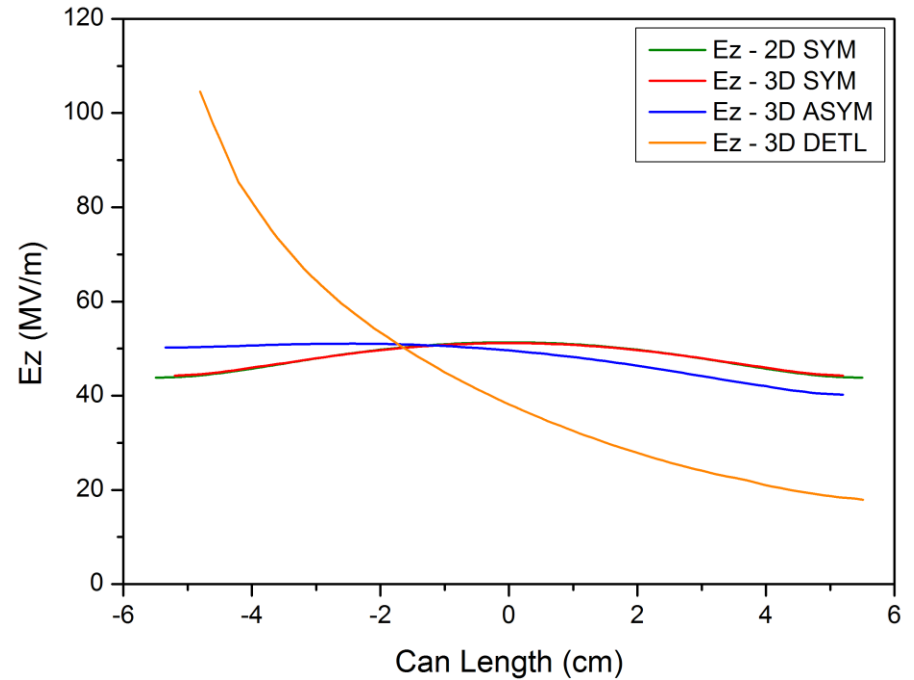

# 3D Model

- Model E
- CST MicroWave Studio
- Full Details Imported CAD Model ([www.grabcad.com](http://www.grabcad.com))

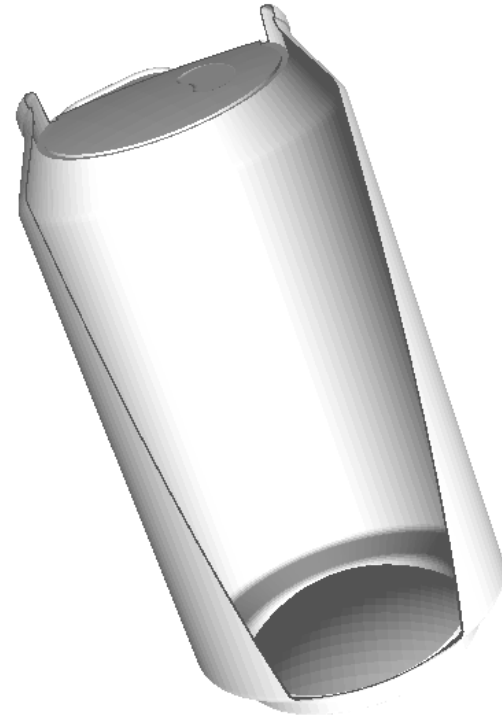
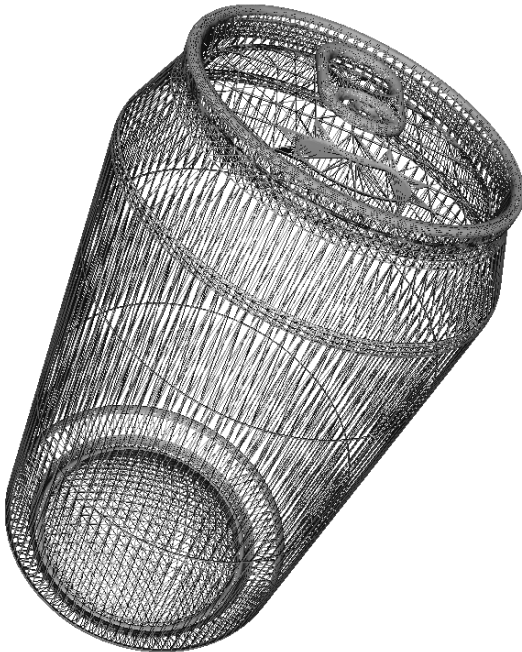

# 3D Model

- Model E
- CST MicroWave Studio

Geometry



Mesh

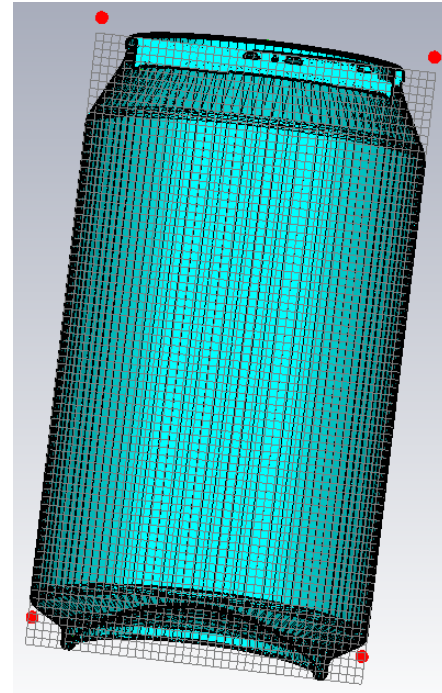

# 3D Model

- Model E
- CST MicroWave Studio
  - Different scaling

$f \approx 3.371$  GHz

Electric Field

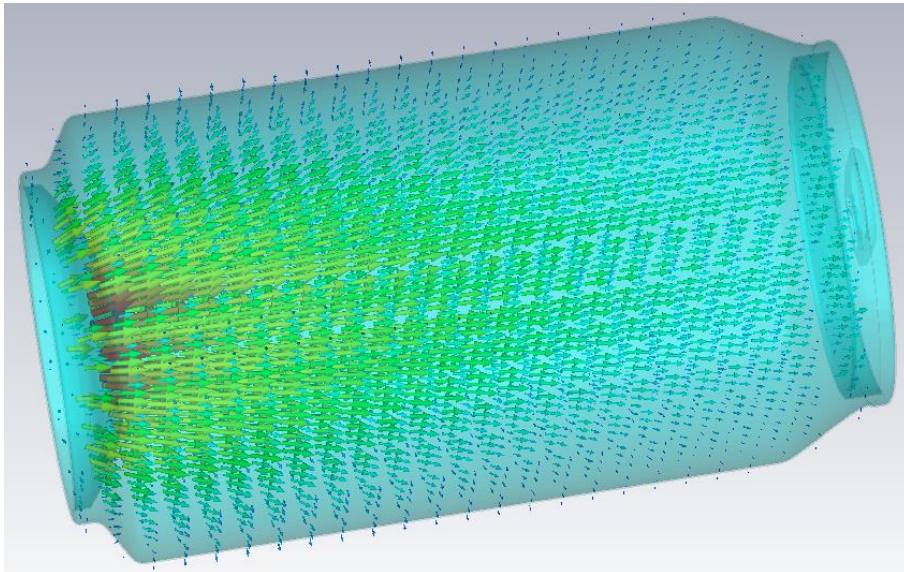

Magnetic Field

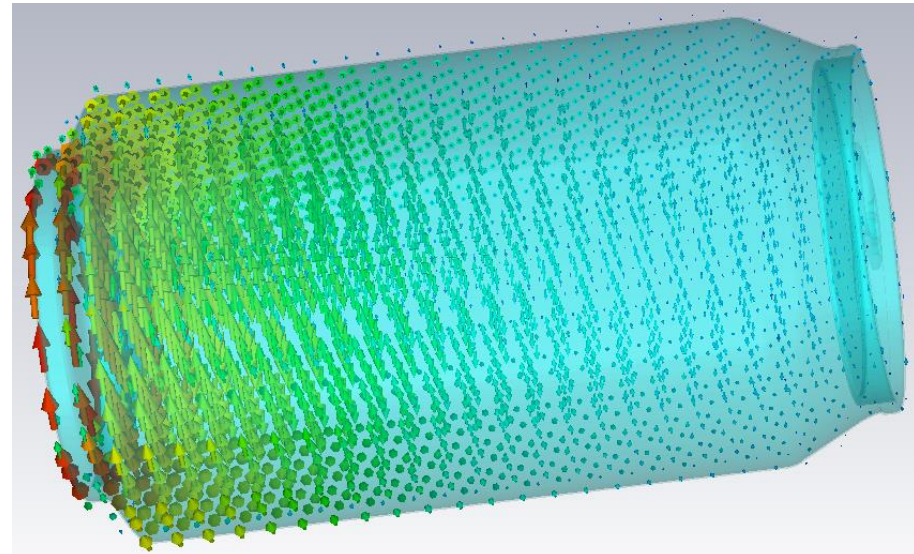



# 3D Model

- Model E
- CST MicroWave Studio
  - Field Normalisation: 1J stored energy/cavity

1D Field Map (Ez on axis)

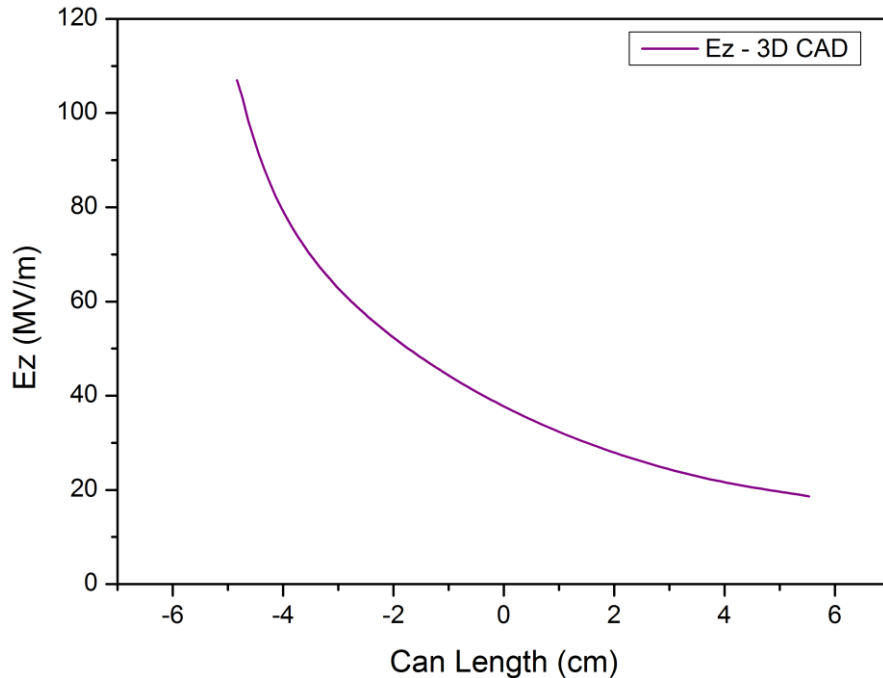

Comparisons...

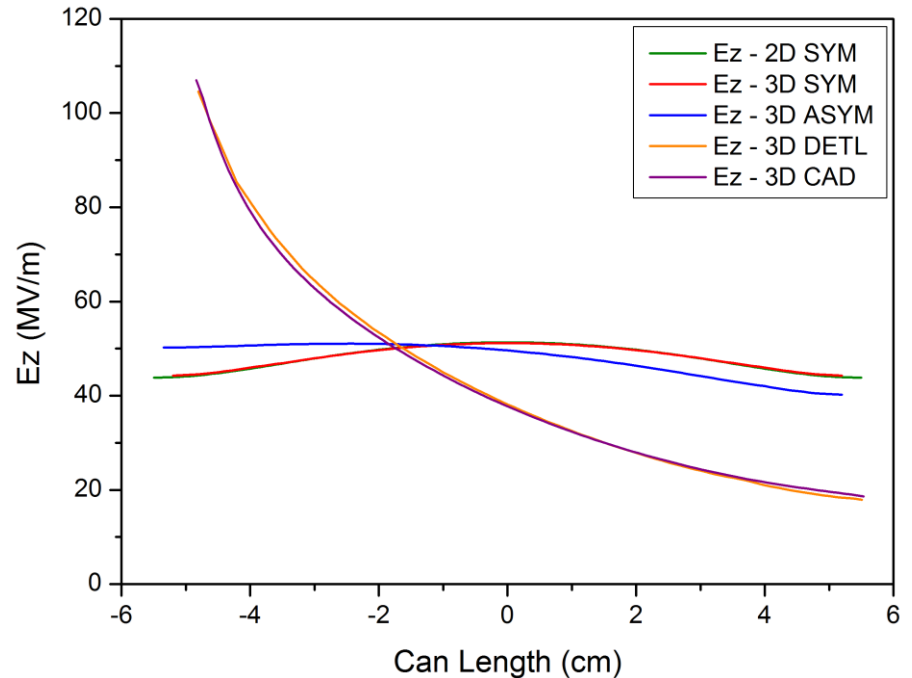

# Experimental Measurement

- Network Analyser: Rohde & Schwarz ZNB8
  - Frequency
  - Q-factor

