

Powering of the Superconducting Circuits: Procedures and Strategies for Circuit Validation

Antonio Vergara
on behalf of the Hardware Commissioning Coordination Team
& SACEC

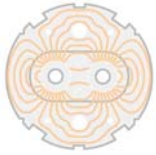

The LHC SC Circuits

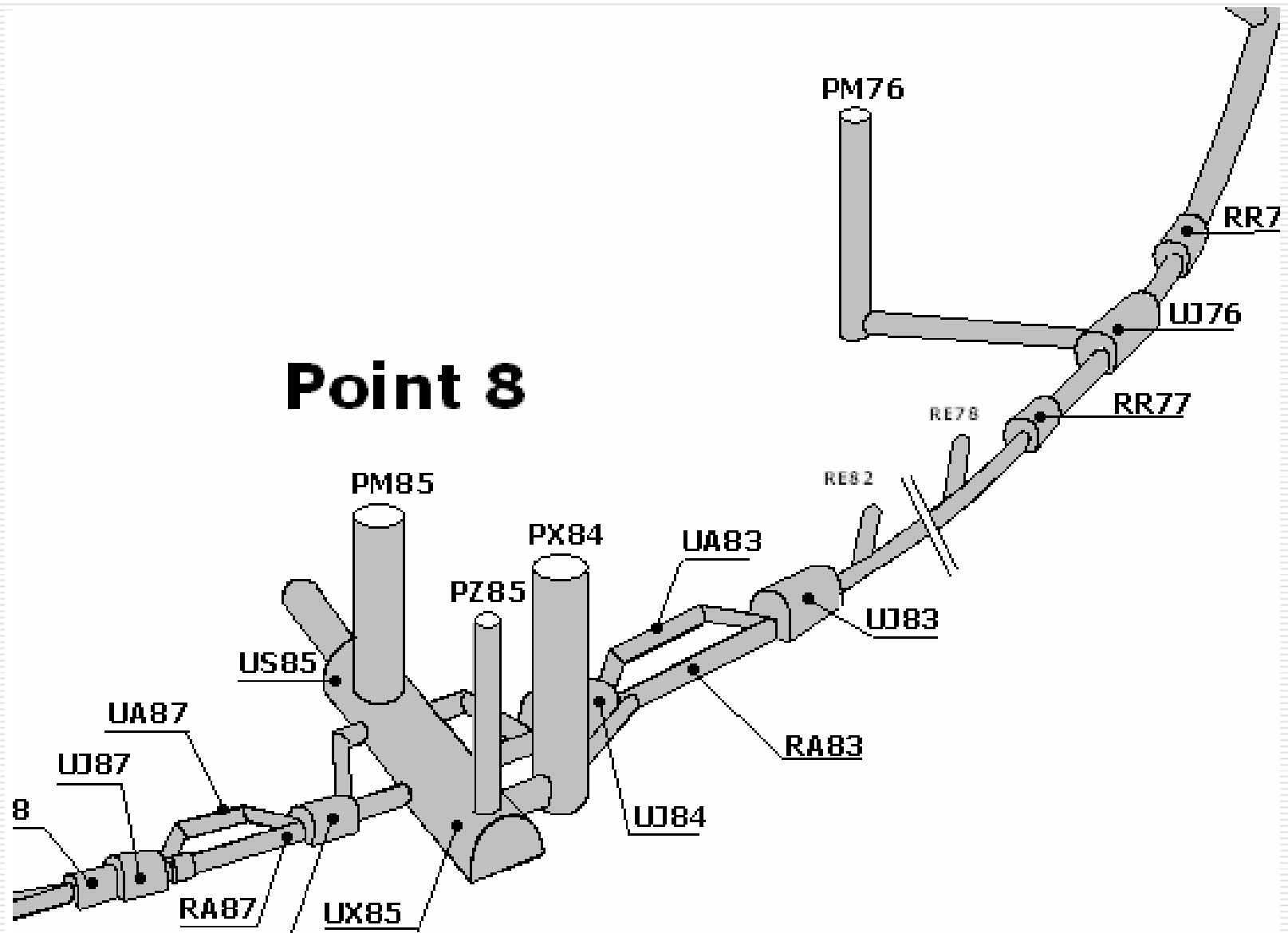



The LHC SC Circuits





Commissioning of a SC Circuit

1. Individual System Tests
2. Short-Circuit Tests

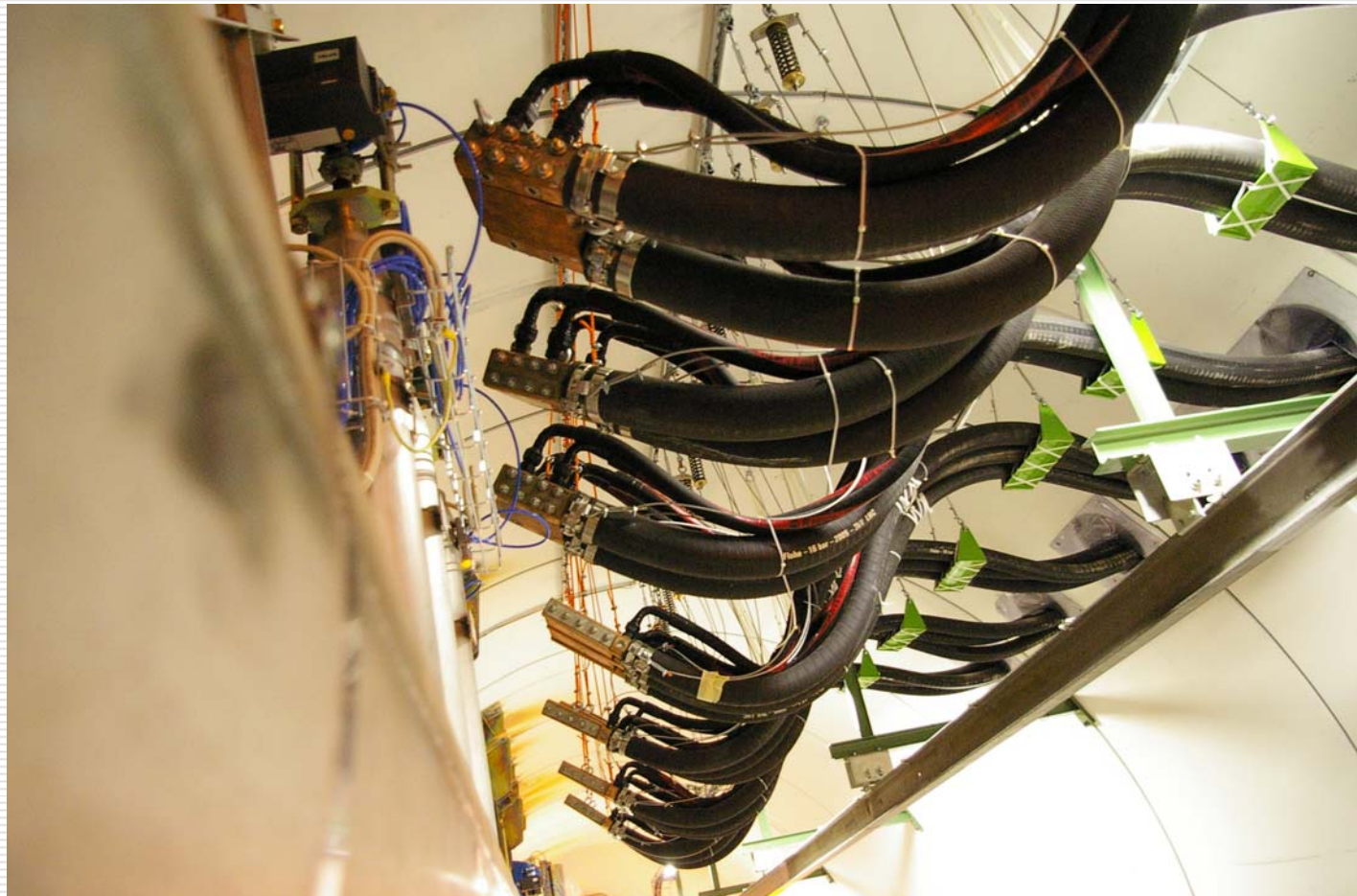



Commissioning of a SC Circuit

1. Individual System Tests
2. Short-Circuit Tests
3. Software Control Tests
 - Control software (Sequencer) debugging
 - PIC – Power converter – QPS Communication
 - Post-Mortem data transmission and analysis
 - Study of parallelisms and interferences between tests
 - Validation of the estimated testing times



Commissioning of a SC Circuit

1.
2.
3.

CERN
CH-1211 Geneva 23
Switzerland

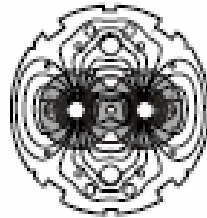

the
**Large
Hadron
Collider**
project

LHC Project Document No.

LHC-D-HCP-0003 rev 1.3

CERN Div./Group or Supplier/Contractor Document No.

AB/AT/TS

EDHS Document No.

519716

Date: 2006-12-11

4.

5.

Hardware Commissioning Procedure

THE COMMISSIONING OF THE HARDWARE IN THE LHC SECTORS

POWERING OF THE SUPERCONDUCTING CIRCUITS OF A SECTOR UP TO NOMINAL CURRENT

Abstract

This document describes the sequence of the steps which lead to the powering of the superconducting circuits of a sector to nominal current. It covers the phases after the electrical connection of the power cables to the current leads up to the powering in unison of all the circuits of a sector to nominal current.



Single Circuit Powering Test

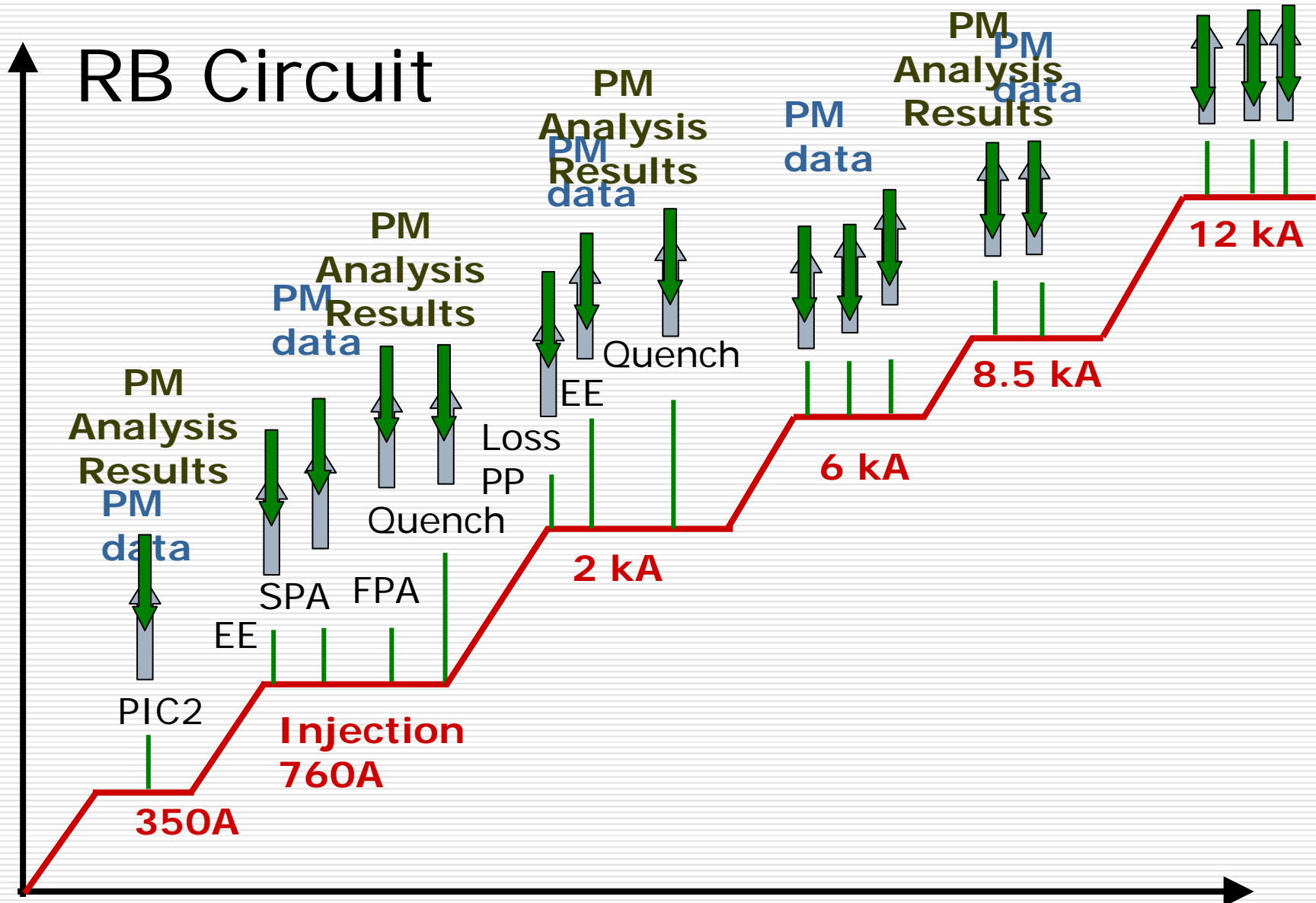



Circuit Types and Circuit Tests

		PIC2	PCS	PL1							PL2						PL3				PL4		PNO							PSQ	PAC
				1	2	3	4	5	6	7	1	2	3	4	5	6	1	2	3	4	1	2	1	2	3	4	5	6	7		
13kA Main																															
IP Q&D																															
IT	RTQX2																														
	RTQX1																														
	RTQXA																														
	RTQXM																														
	RQX																														
600A EE																															
600A no EE CR																															
600A no EE																															
80-120A																															
60A																															



The Commissioning Scenario: Schedule

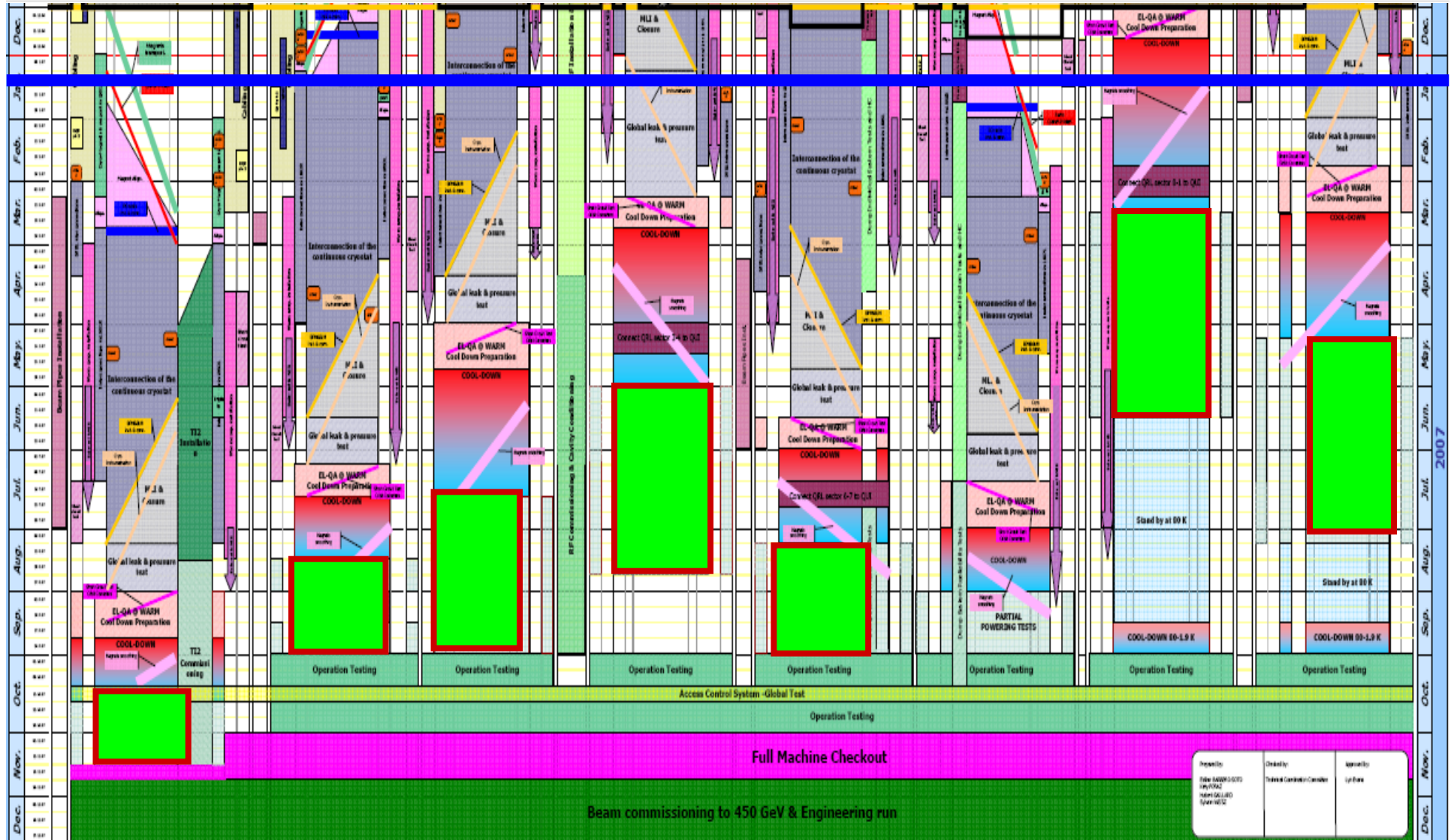



The Commissioning Scenario: Schedule

SECTOR 7-8

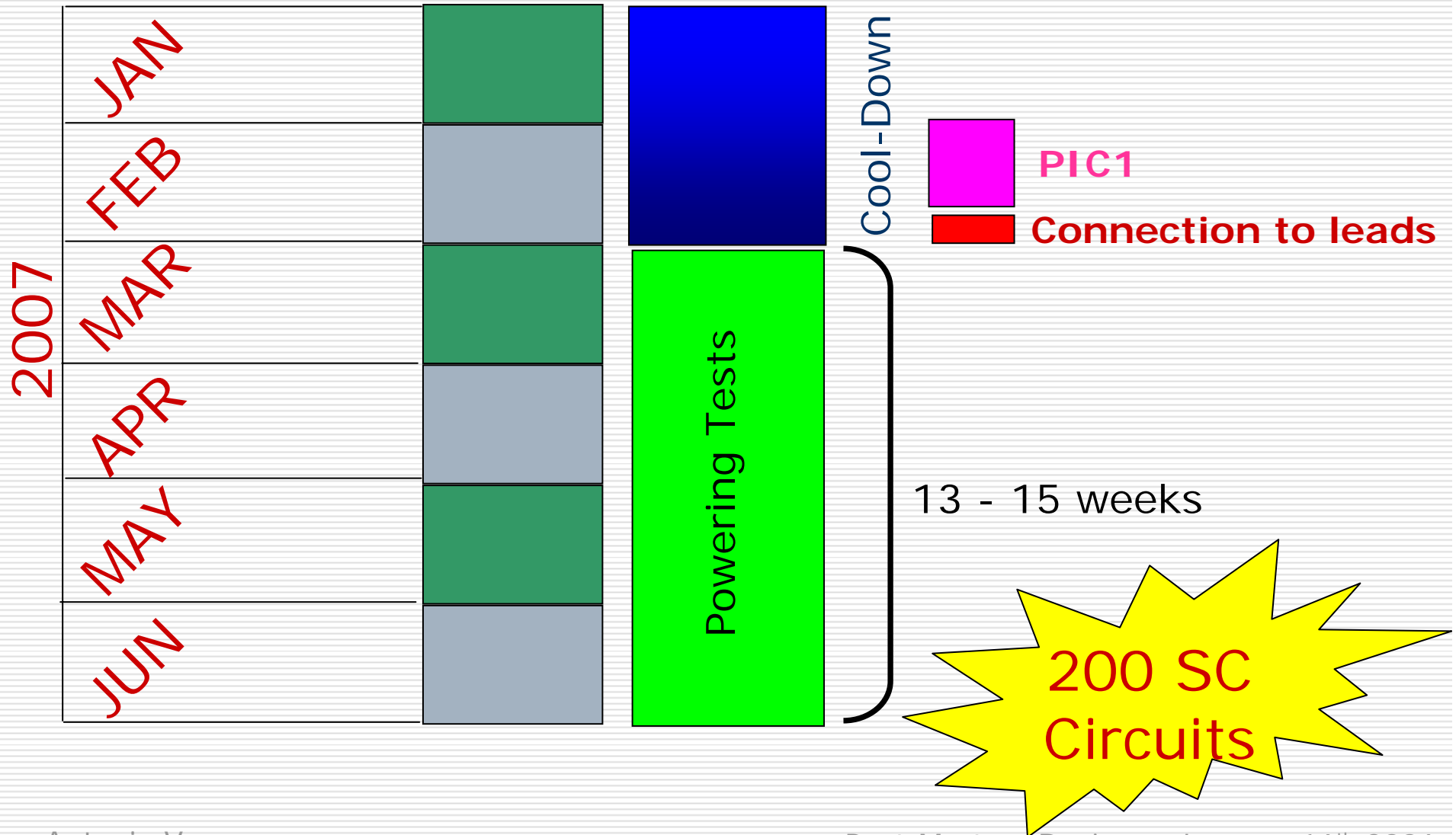



The Commissioning Scenario

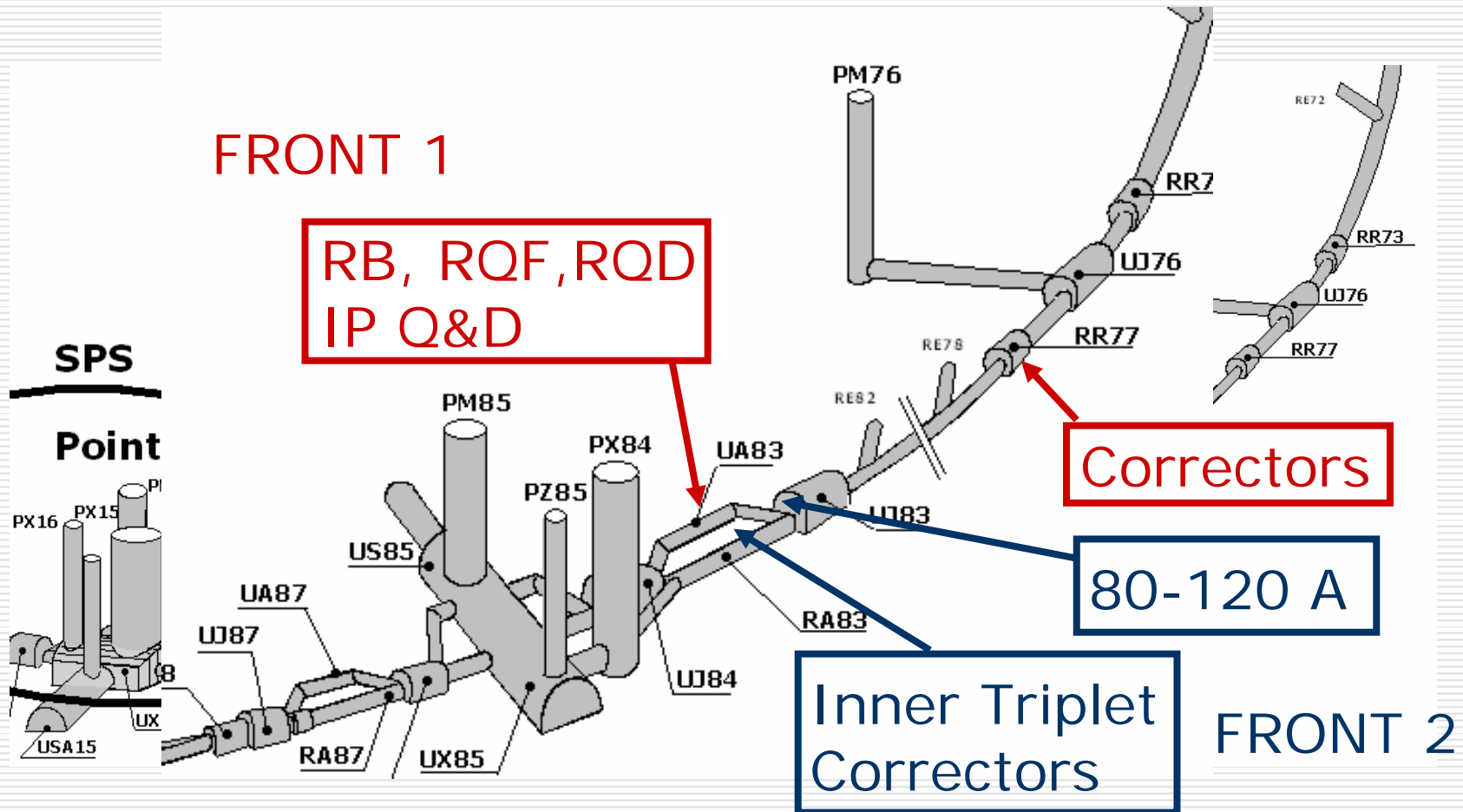



Parallelisms and Constraints

- The 3 types of parallelisms:
 - Parallelisms between sectors
 - Parallelisms between fronts
 - Parallelisms between circuits – SOC

SOC: Set Of Circuits.
Battery of circuits
commissioned in parallel
by the same front



- The 3 types of parallelisms:
 - Parallelisms between sectors
 - Parallelisms between fronts
 - Parallelisms between circuits – Battery

- General Constraints:
 - One Front can commission only one circuit or one battery at a time
 - Tests carried out by one Front should be transparent to the other ones



Constraints on Parallel Commissioning

1. Two **sectors** cannot test simultaneously
 - i. Two or more 13kA circuits
2. Two **fronts** cannot test simultaneously
 - i. Circuits in the same powering subsector
 - ii. Circuits in the same DFB
3. A **SOC (battery)** cannot
 - i. Include circuits above 600A
 - ii. Imply more than one DFB
 - iii. Imply more than two DFB chimenys
 - iv. Include circuits sharing the same QPS controller
 - v. Include circuits from different circuit type (?)
 - vi. Include circuits from different powering subsectors



Developed Tools

- ❑ The Sequencer
- ❑ Reference and LSA Databases
- ❑ Individual Supervision Systems
- ❑ Alarms – Laser, Logging
- ❑ Test Management Software: SOC Editor
- ❑ Post-Mortem Local Analysis Tools
- ❑ Post-Mortem Global Analysis Tool
- ❑ MTF



What do we need from the Post-Mortem?

- The Post-Mortem data analysis tools should provide to the different experts (MPP, individual equipment experts, Mr Circuit, HCC, etc.):
 - Fast and reliable tools to analyse the behaviour of the different equipment after each commissioning step
 - Information automatically extracted from the Post-Mortem data after each provoked or natural event
 - Both a local and global overview of the systems under test reliable and clear enough to allow the go / no go for the next commissioning step.



The Post-Mortem analysis is an essential tool, not only for a reliable and safe operation of the LHC, but also for achieving proper commissioning of the LHC super-conducting circuits respecting the current LHC project milestones.

...thank you