

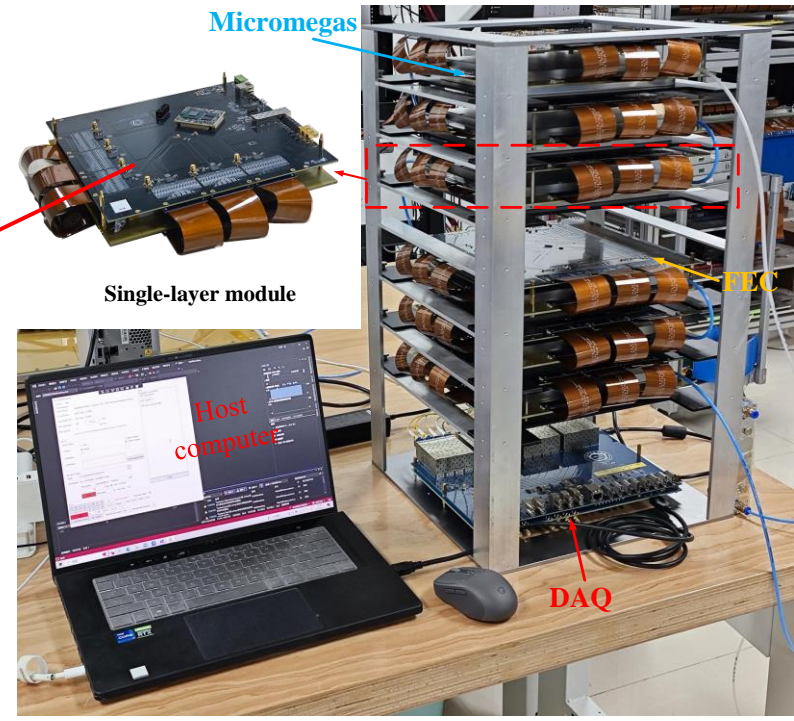

Electronics Design

➤ Front-End Electronics (FEC) based on ADAS1128

- Dynamic range: $-660 \text{ fC} \sim 543.1 \text{ pC}$
- 128-channel integrated analog-to-digital conversion
- Noise(single channel): less than 0.4 fC
- Each FEC board integrates 6 ASICs
- Readout unit with 768 channels
- Integrated with a 15 cm x 15 cm Micromegas as a single module
- Scalable electronics system
- FEC + DAQ
- Custom protocol optical fiber communication

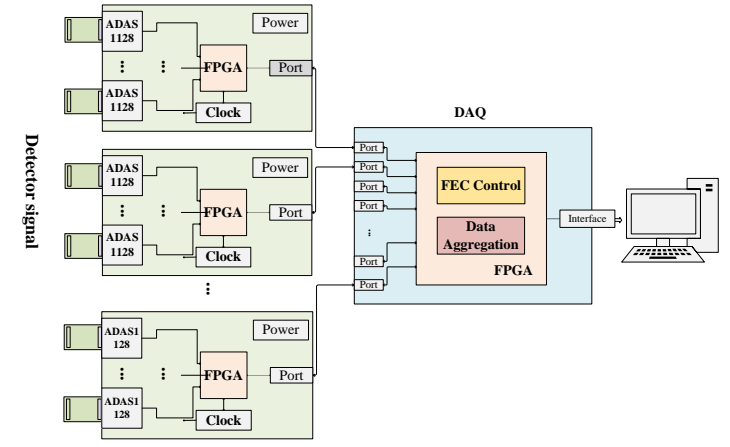
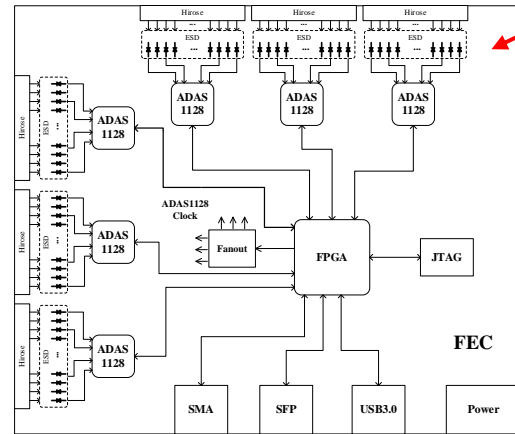
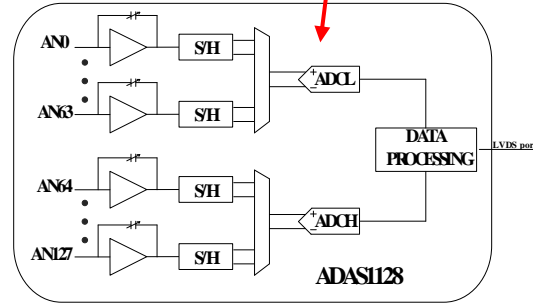

ID: #86 A Compact Readout Electronics based on Current Amplifier for Micromegas Detector

Ting Wang, Yu Wang, Zhihang Yao, et al



Test and Result

➤ Performance Test

- Noise: less than **0.68 fC** (95% of Channels)
- Calibration: $\text{Code} = 213.6 * \text{Charge (fC)} + 16365$.

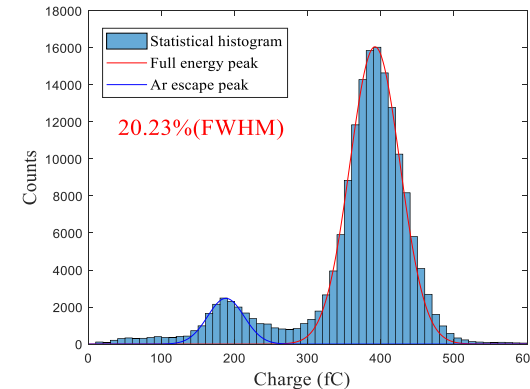
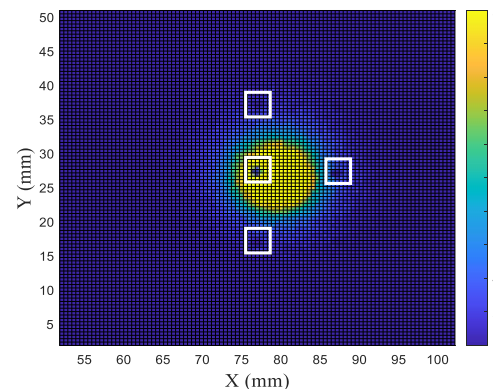
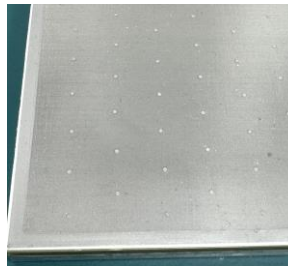

➤ X-Ray Source Test

- The full energy peak is 389.3 fC, with energy resolution of **20.23% @ 5.9keV (FWHM)**.
- The thermal adhesive pads of detector can be observed.

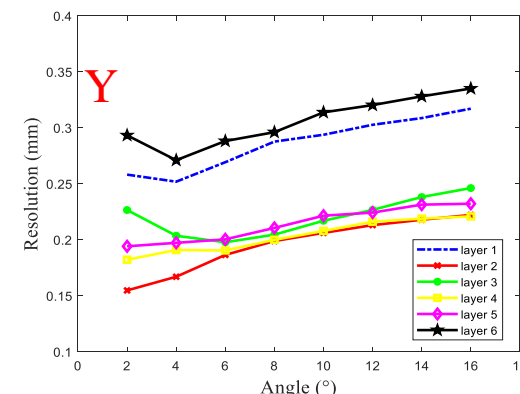
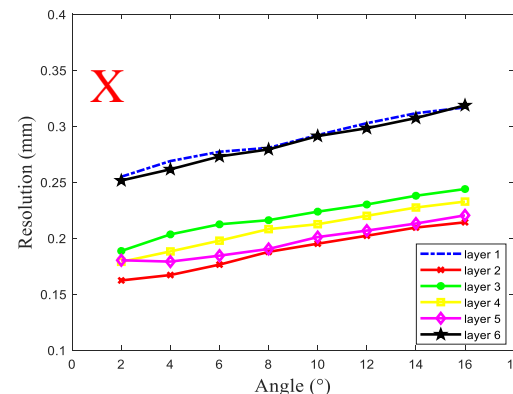

➤ Cosmic Ray Muon Test

- The main distribution of muon deposited energy satisfies the **Landau-Gaussian distribution**.
- For small-angle muon incidence, the spatial resolution of the 6-layer Micromegas detector is **less than 200 μm**.
- Most of the 6-layer Micromegas detector' s efficiency is **over 95%**.

