



**AND THE
FORWARD PHYSICS FACILITY**

Light Dark World International Forum 2020

Jonathan Feng, UC Irvine, 15 December 2020



SIMONS
FOUNDATION



HEISING-SIMONS
FOUNDATION



UC
IRVINE

OUTLINE

INTRODUCTION AND MOTIVATION

FASER AND FASER_v

FORWARD PHYSICS FACILITY

INTRODUCTION AND MOTIVATION

INTRODUCTION

- We are living in interesting times: the Higgs boson has been discovered, but many of the grand motivations for new physics, although still interesting, are not as compelling as they once were.
 - Gauge hierarchy problem
 - Supersymmetry
 - WIMP dark matter
- In terms of major experiments and projects, we are also at a crossroads.
 - In Asia, we are waiting for a decision about the ILC
 - In Europe, the European Strategy Update for Particle Physics pushed definitive decisions to the future
 - In North America, the Snowmass process is underway, but its conclusion may be postponed to 2022, given COVID-19 delays
- For all these reasons, perhaps it's a good time to go back to the drawing board and re-evaluate where we've been and where we are.

Particle
Colliders

THE PARTICLE PHYSICS LANDSCAPE

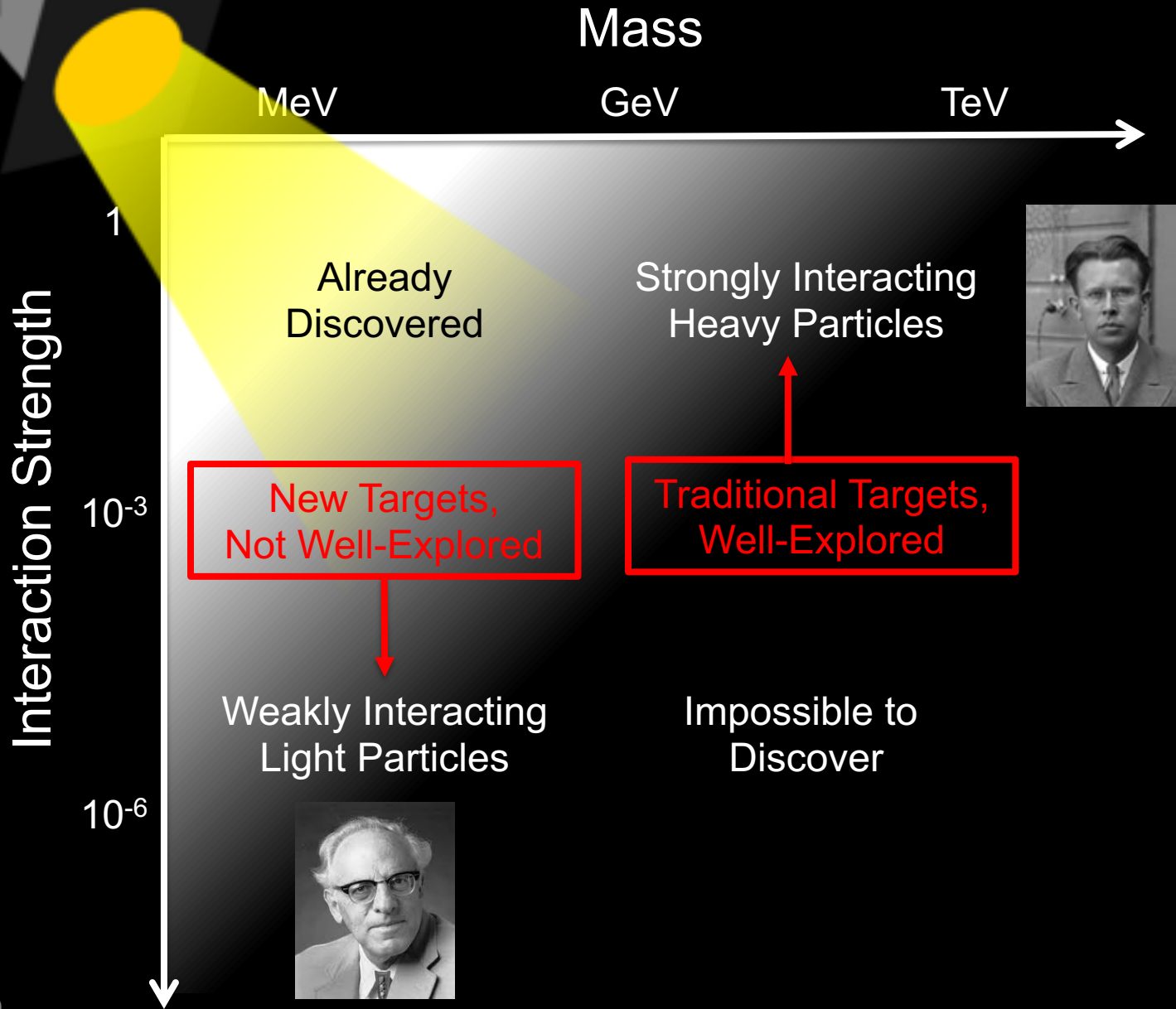

THE THERMAL RELIC LANDSCAPE

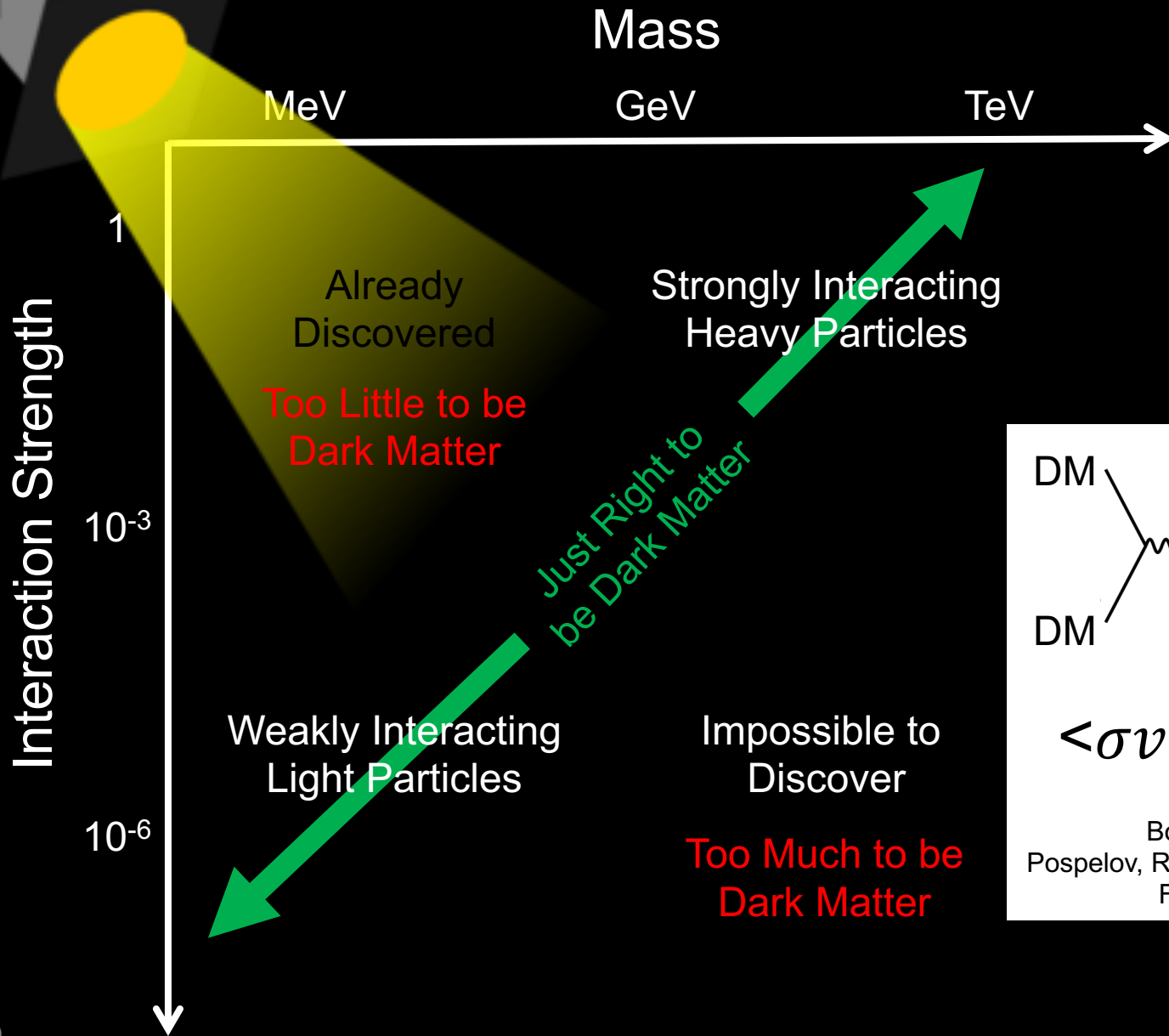

$$\langle \sigma v \rangle \sim \frac{\epsilon^2}{m_{A'}^2}$$

Boehm, Fayet (2003)
 Pospelov, Ritz, Voloshin (2007)
 Feng, Kumar (2008)

LIGHT, WEAKLY-INTERACTING PARTICLES

- To search for light and very weakly-interacting particles, we need very large event rates.
- The traditional place for this is the (low-energy) intensity frontier.
- But this is not the only possibility: there is a enormous event rate of $\sigma_{\text{tot}} \sim 100 \text{ mb}$ at high energy colliders.
- Most of this goes down the beam pipe in the forward direction, where existing detectors are blind.
- **We are missing half of the LHC's discovery potential if we don't bother to look!**

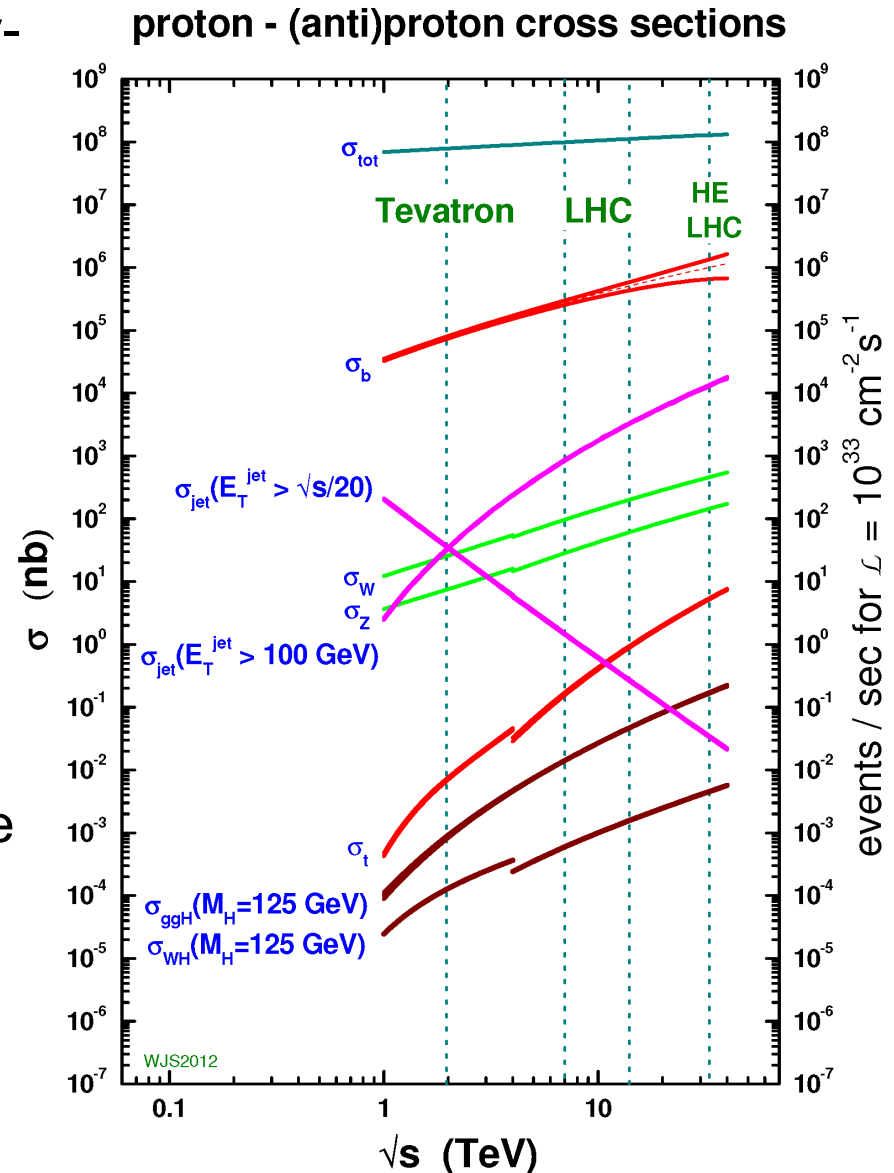

MOTIVATIONS FOR NEW EXPERIMENTS

- It is now becoming clear that the forward region at the LHC contains a rich physics program that has been completely untapped to date.
- BSM: New particles may be light and weakly interacting.
 - They typically escape along the beampipe, may also decay far away.
 - Rich BSM physics program: $\pi \rightarrow$ dark photon, $B \rightarrow$ dark Higgs, $\gamma \rightarrow$ ALP, etc.
 - This motivates FASER.

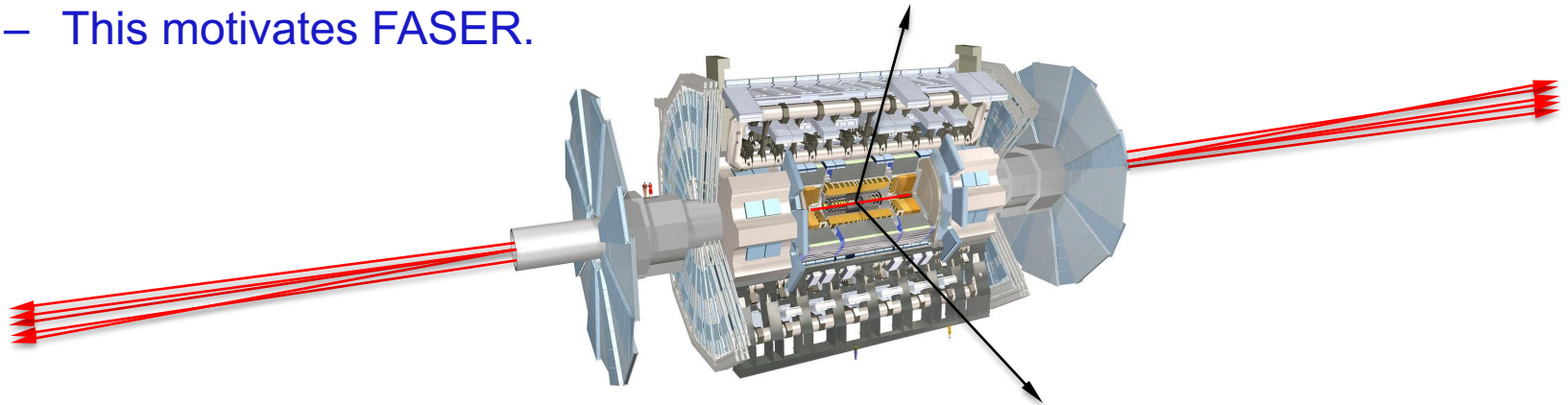

- SM: Known particles may also be light and weakly interacting: neutrinos!
 - To date no collider neutrino has ever been detected: low-energy ν s have small cross sections, and high-energy (TeV) ν s escape along the beampipe.
 - This means that the far-forward region also has a rich SM physics program: can initiate a brand new opportunity of neutrino physics at the LHC.
 - This motivates FASER ν .

FASER AND FASER_v

THE BASIC IDEA

- For decades, new physics searches have focused on high p_T , “low cross section physics” (fb, pb, nb).
- But new particles may be light and very weakly interacting.
 - Weakly-interacting \rightarrow need large SM event rate to see them
 - Light \rightarrow we can produce them in π , K , D , B decays
- Conclusion: look where the pions (and kaons and D and B mesons) are.
 - For 13-14 TeV pp collisions, $\sigma_{\text{tot}} \sim 100$ mb
 - For the upcoming Run 3 from 2022-24, expect 150 fb^{-1} . The LHC will produce an enormous number of pions ($N_\pi \sim 10^{17}$), and most of them are at low p_T .

Feng, Galon, Kling, Trojanowski (2017)

THE BASIC IDEA

- Of course, we can't put a reasonably-sized detector on the beamline near the IP – it would block the proton beams.
- However, weakly-interacting particles also typically travel a long distance before interacting or decaying, so we can place the detector ~ 500 m away, after the beam curves away.
- Consider TeV-energy particles produced in pion decay.
 - Typical p_T : m_π (or Λ_{QCD})
 - Typical angle relative to the beam axis: $\Lambda_{\text{QCD}} / \text{TeV} \sim 0.2$ mrad.
 - Typical spread in transverse plane after 500 m: $500 \text{ m} (0.2 \text{ mrad}) \sim 10 \text{ cm} !$

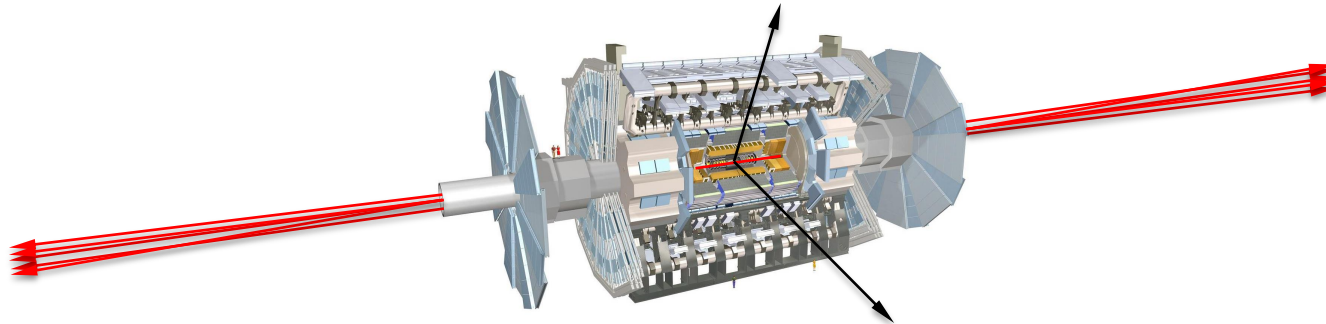

- These general considerations motivate a small, fast, inexpensive experiment placed ~ 500 m downstream of an interaction point: FASER, the Forward Search Experiment at the LHC.

FASER LOCATION

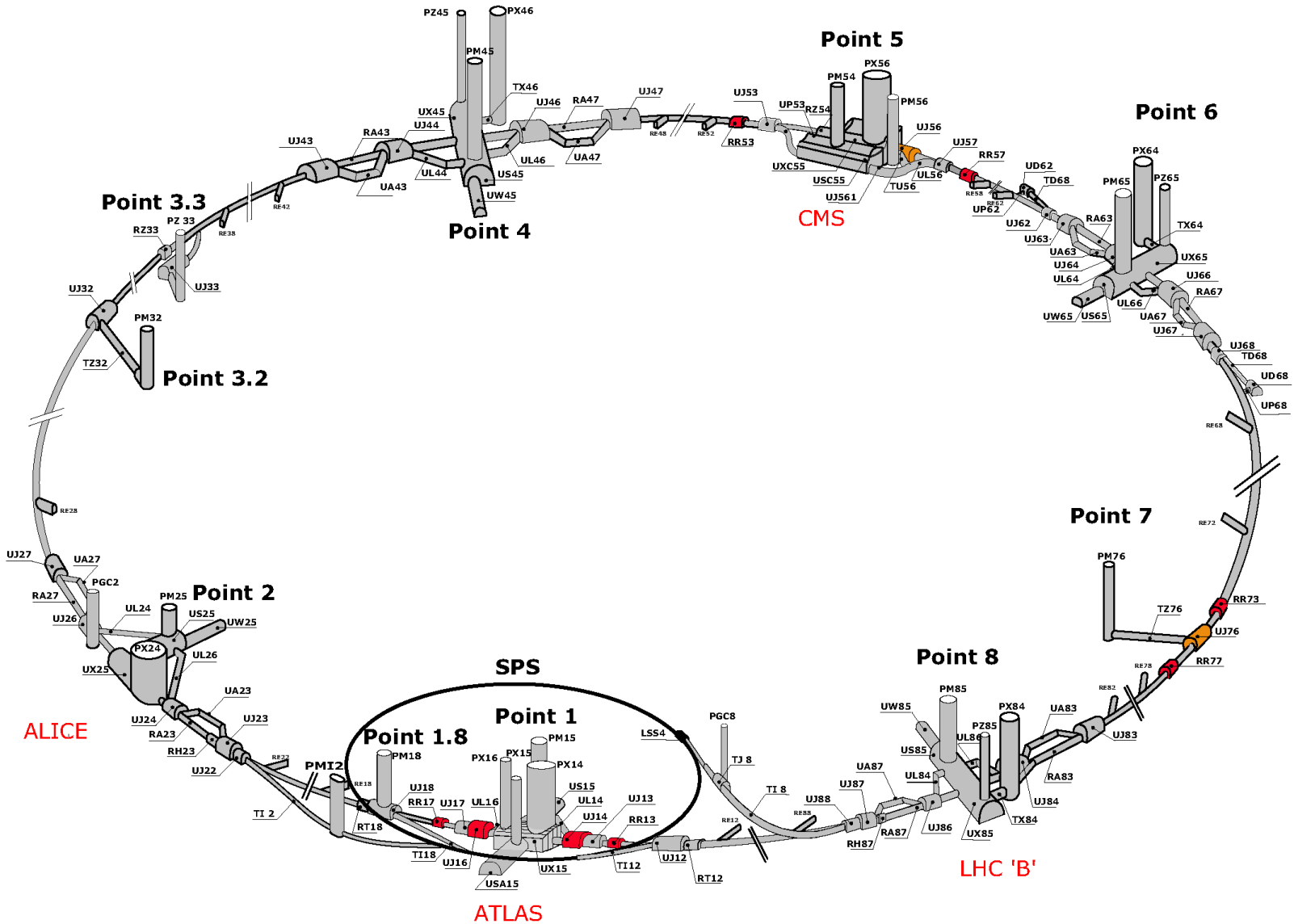

FASER LOCATION

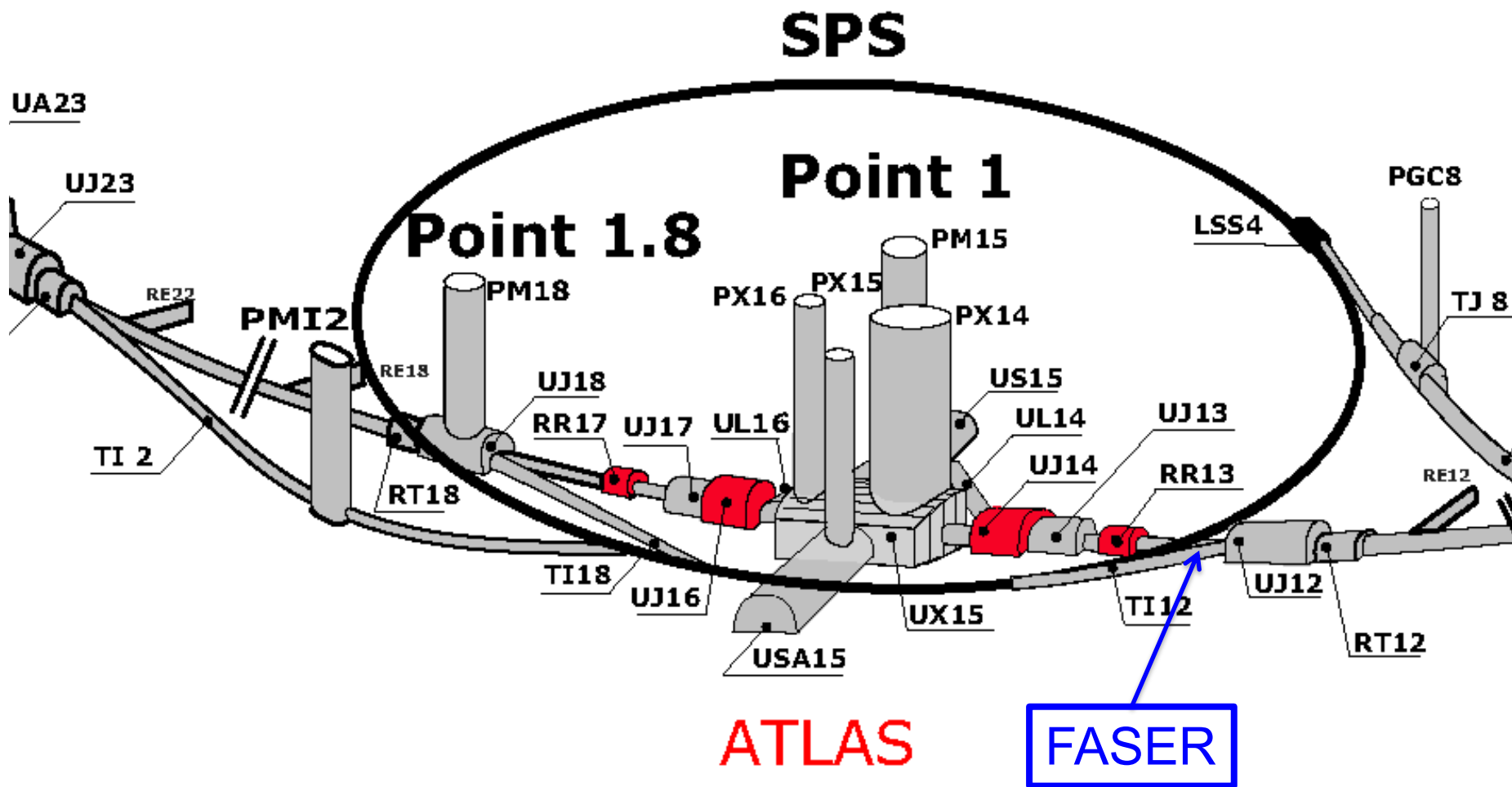

LOCATION OF FASER

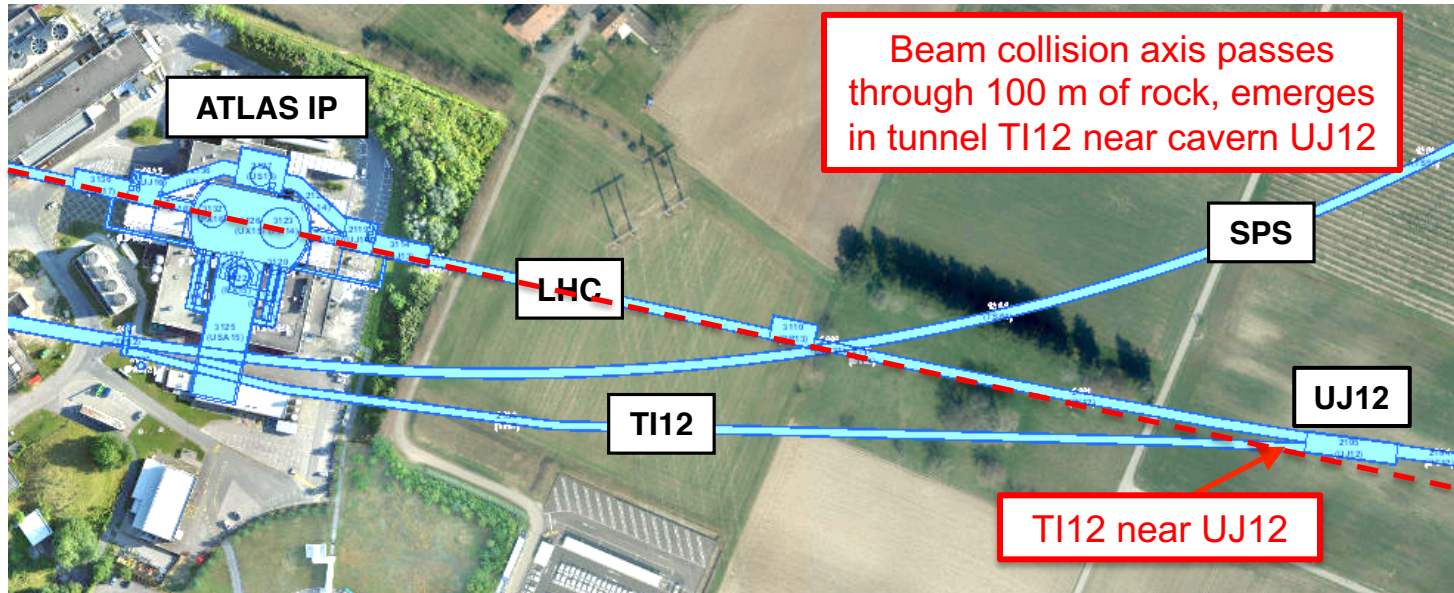

PARTICLE PATH FROM ATLAS TO FASER

Dougherty, CERN Integration (2019)



AN EXAMPLE: DARK PHOTONS AT FASER

- The dark photon
 - is massive, with a mass $m_{A'}$
 - has couplings to SM particles suppressed by a small parameter ϵ
- It can be produced, for example, in pion decay:
- It can decay to particle/anti-particle pairs:

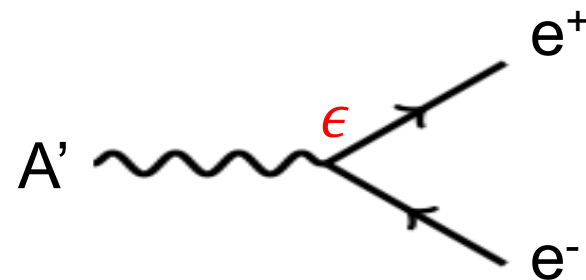
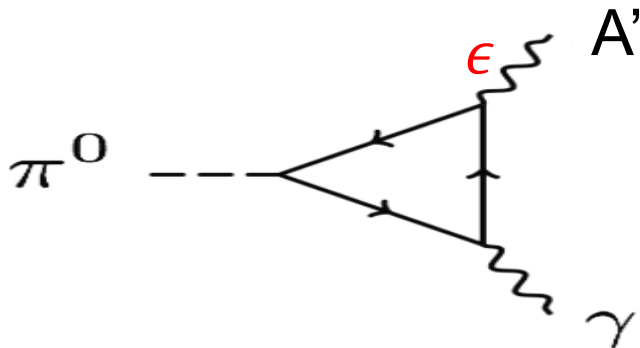

$$B(\pi^0 \rightarrow A' \gamma) = 2\epsilon^2 \left(1 - \frac{m_{A'}^2}{m_{\pi^0}^2}\right)^3$$

$$L = v\tau\gamma \sim (100 \text{ m}) \left[\frac{10^{-5}}{\epsilon}\right]^2 \left[\frac{100 \text{ MeV}}{m}\right]^2 \left[\frac{E}{\text{TeV}}\right]$$

AN EXAMPLE: DARK PHOTONS AT FASER

Pions at the IP

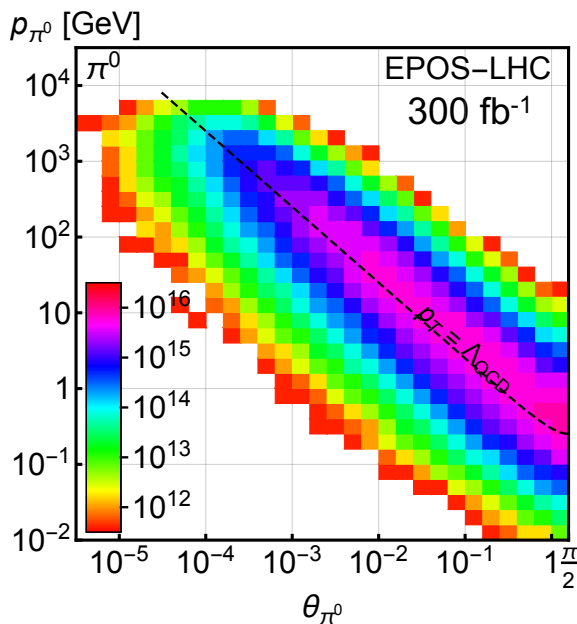

A's at the IP

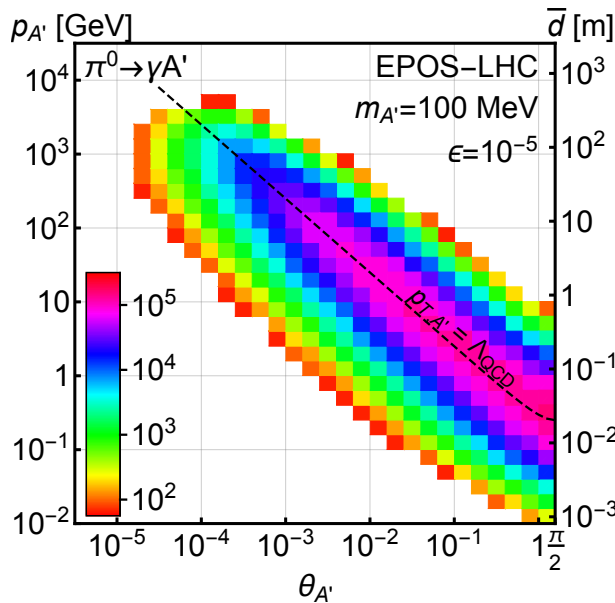

A's decay in [480m, 483m]

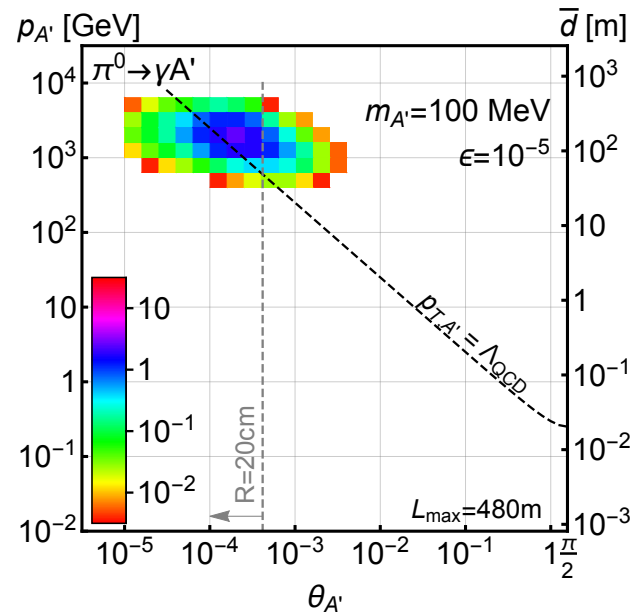

- Production is peaked at $p_T \sim \Lambda_{QCD} \sim 250$ MeV
- Enormous event rates: $N_\pi \sim 10^{15}$ per bin
- Simulations greatly refined by LHC data

- Production is peaked at $p_T \sim \Lambda_{QCD} \sim 250$ MeV
- Rates highly suppressed by $\epsilon^2 \sim 10^{-10}$
- But still $N_{A'} \sim 10^5$ per bin

- Only highly boosted \sim TeV A's decay in FASER
- Rates again suppressed by decay requirement
- But still $N_{A'} \sim 100$ signal events, and almost all are within ~ 10 cm of “on axis”

FASER'S DISCOVERY POTENTIAL

- The signal is spectacular: 2 opposite-sign \sim TeV charged tracks emerging from 100 m of rock, pointing back to the ATLAS IP.
- In Run 3, FASER will start probing new dark photon parameter space with the first fb^{-1} , and extend its sensitivity in the 10 – 100 MeV mass range.

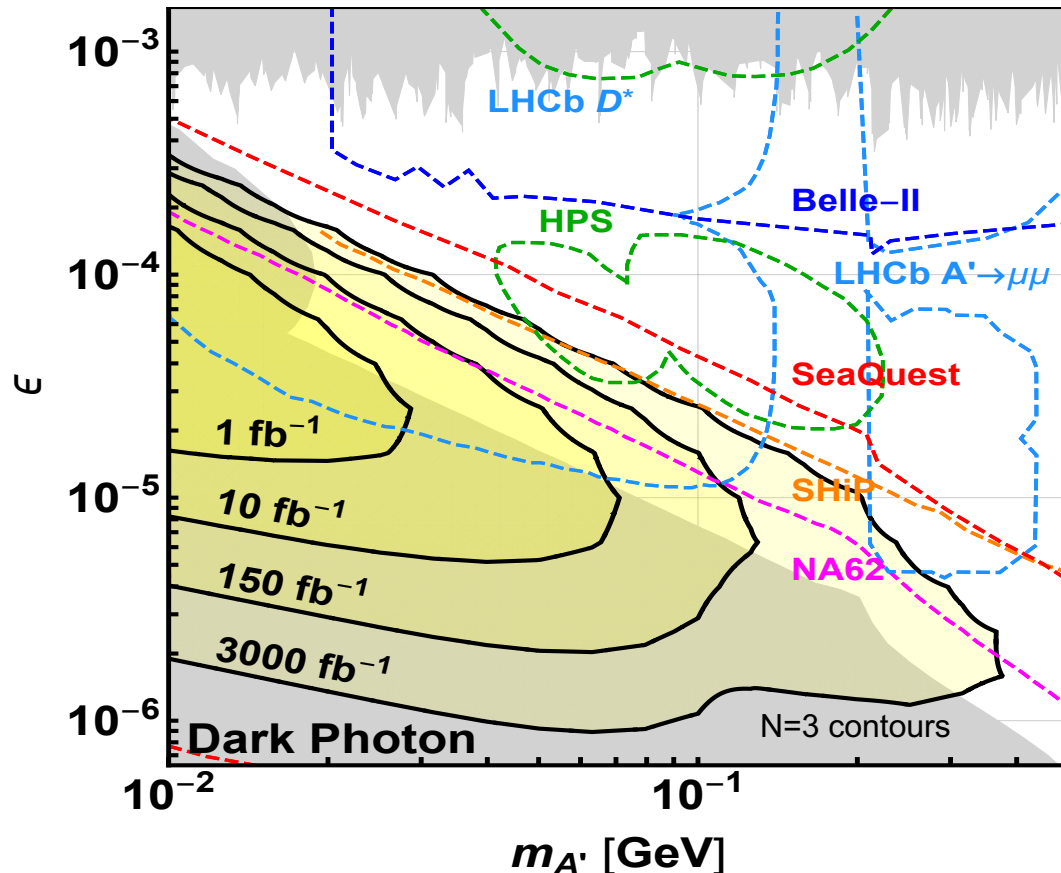

TARGETS IN DARK PHOTON PARAMETER SPACE

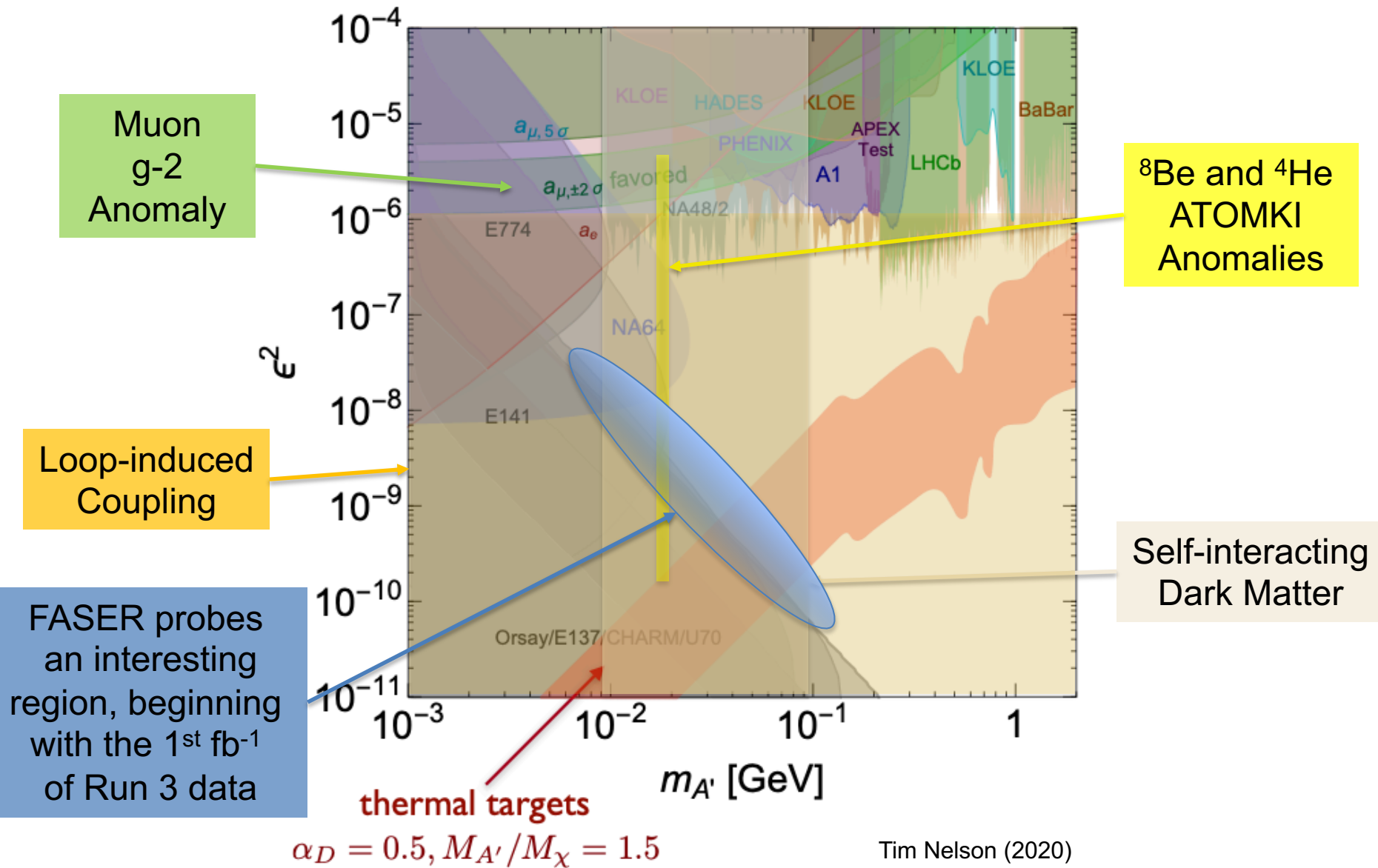

ANOTHER EXAMPLE: AXION-LIKE PARTICLES

- FASER is sensitive to many other LLP signals.
- For example, ALPs coupled to photons
 - \sim TeV photon from IP travels 130 m, collides with the TAN
 - Creates ALP through Primakoff process
 - ALP decays through $a \rightarrow \gamma\gamma$ in FASER: a “light shining through (100 m) wall experiment.”

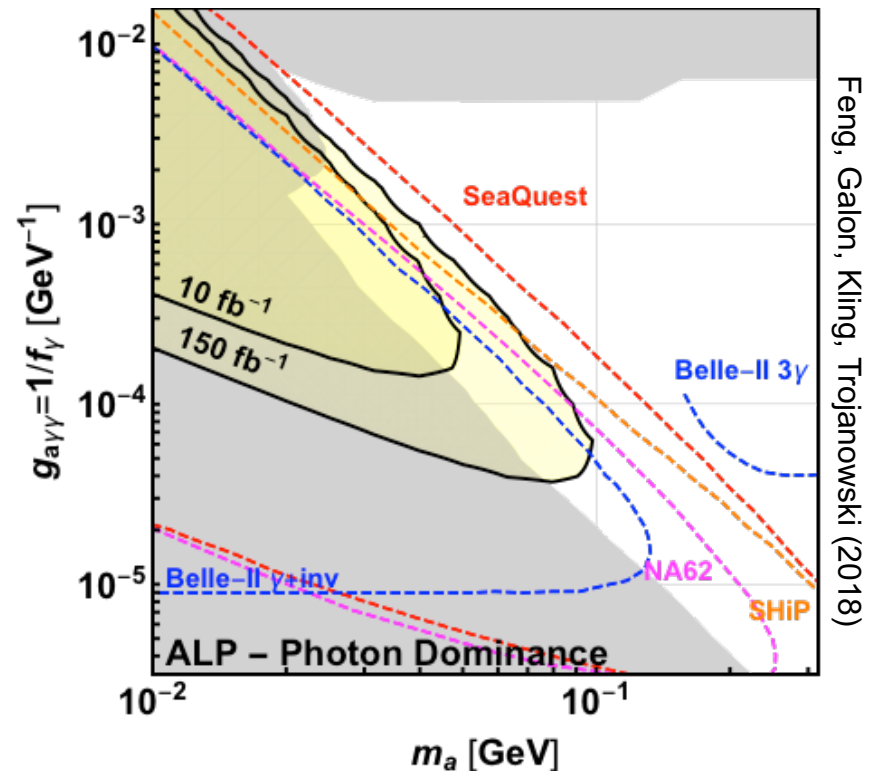
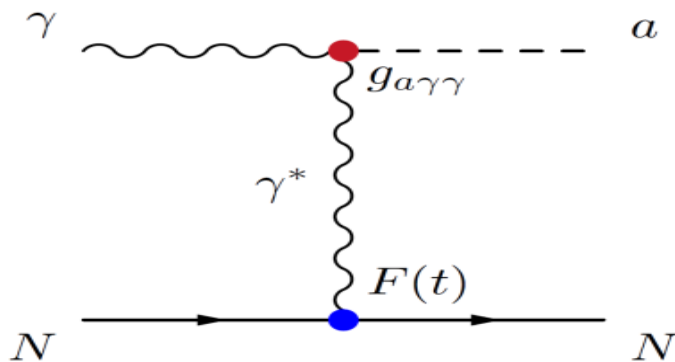
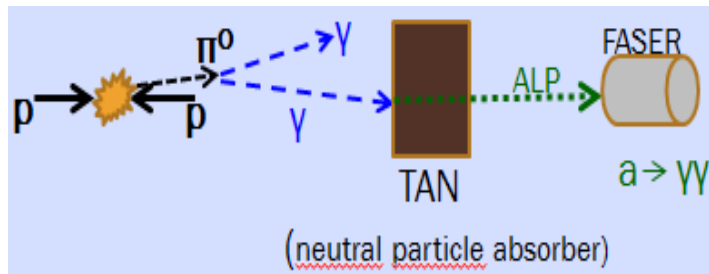

SM PHYSICS: FAR-FORWARD NEUTRINOS

- In addition to the possibility of hypothetical new light, weakly-interacting particles, there are also known light, weakly-interacting particles: neutrinos.
- But the high-energy ones, which interact most strongly, are overwhelmingly produced in the far forward direction, travel down the beampipe, and escape all existing detectors. **No collider neutrino has ever been detected.**
 - If they can be detected, there is a rich SM physics program: all flavors are produced ($\pi \rightarrow \nu_\mu$, $K \rightarrow \nu_e$, $D \rightarrow \nu_\tau$) and both neutrinos and anti-neutrinos.

De Rujula, Ruckl (1984); Winter (1990)

- Currently two experiments targeting this opportunity: FASER ν , to be located just in front of FASER in TI12, and SND, proposed for the opposite side of ATLAS in TI18.

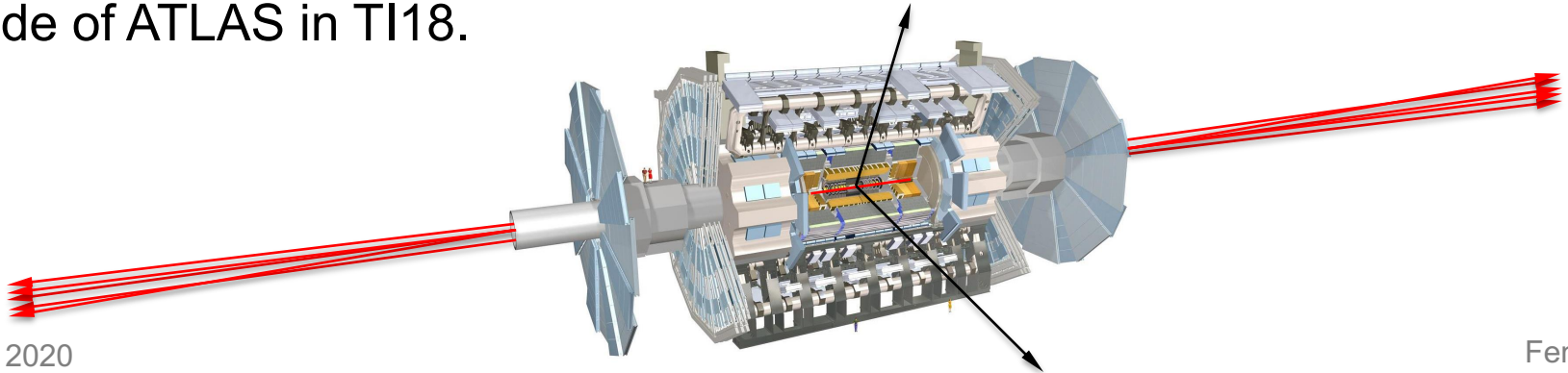

NEUTRINO FLUXES

- In fact, we have probably already seen our first TeV collider neutrino.
- 2018: FASER pilot ~ 30 kg emulsion detectors collected 12.5 fb^{-1} on the beam collision axis (installed and removed during Technical Stops).
- Expect ~ 10 neutrino interactions. Several neutral vertices identified, likely to be neutrinos. Analysis ongoing.

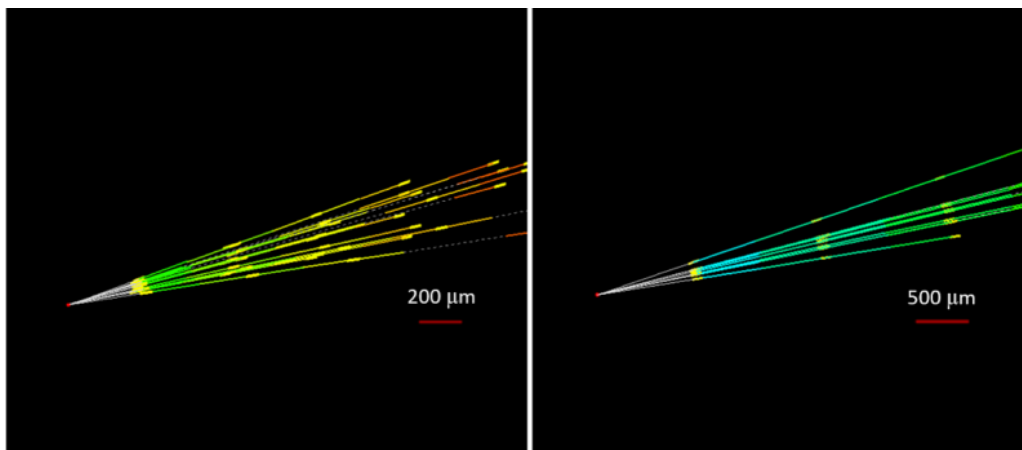

NEUTRINO PHYSICS

- 2022-24: FASER ν will collect data with 1.1-tonne detector in Run 3
 - Will detect the first collider neutrino.
 - Will record ~ 1000 ν_e , $\sim 10,000$ ν_μ , and ~ 10 ν_τ interactions at TeV energies, the first direct exploration of this energy range for all 3 flavors.
 - Will double the world's supply of tau neutrinos.
 - Will be able to distinguish muon neutrinos from anti-neutrinos by combining FASER and FASER ν data, and so measure their cross sections independently.

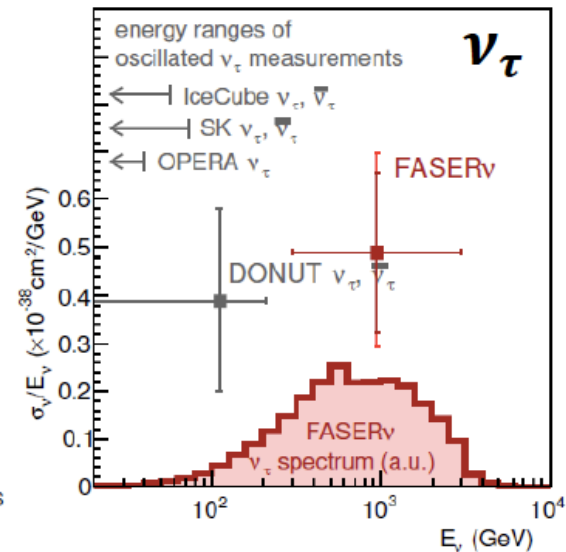
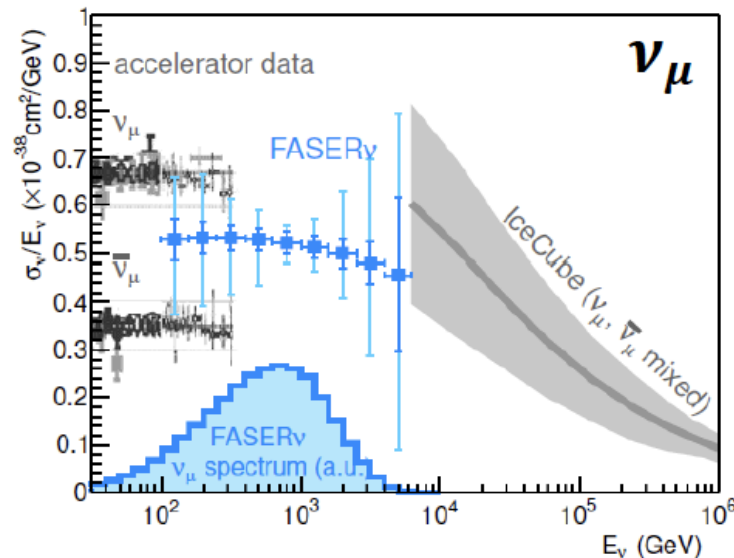
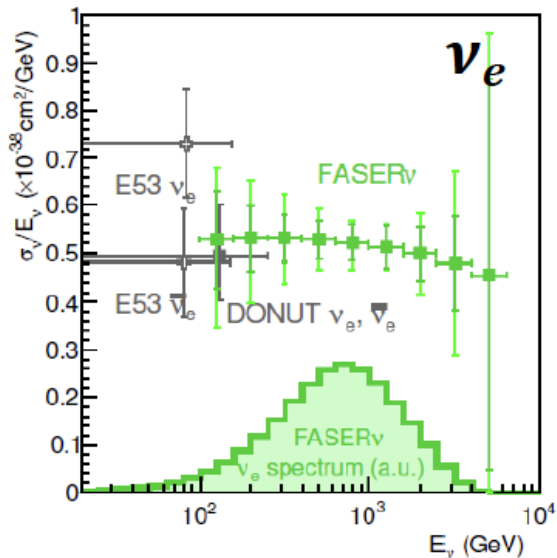

FASER Collaboration 1908.02310 (2019)

QCD PHYSICS

- The forward production of hadrons is currently subject to large uncertainties. Far-forward neutrino experiments will provide useful insights.
 - On-axis and off-axis neutrino detectors will provide complementary information ($\pi \rightarrow \nu_\mu$, $K \rightarrow \nu_e$, $D \rightarrow \nu_\tau$)
 - Interactions with target nuclei (lead, tungsten) probe nuclear pdfs
 - Strange quark pdf through $\nu s \rightarrow lc$
 - Refine simulations that currently vary greatly (EPOS-LHC, QGSJET, DPMJET, SIBYLL, PYTHIA...)
 - Forward charm production, intrinsic charm
 - Essential input to astroparticle experiments; e.g., distinguish galactic neutrino signal from atmospheric neutrino background at IceCube

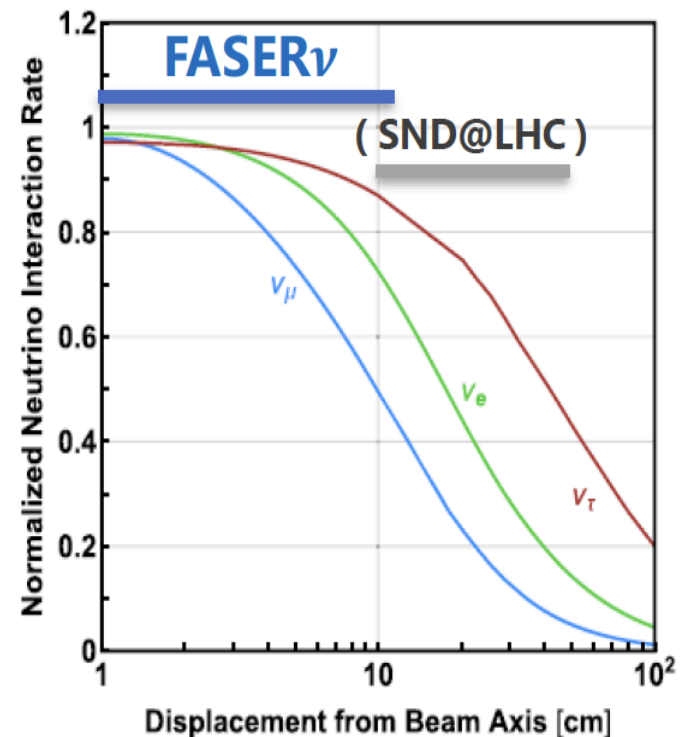

FASER TIMELINE AND ACKNOWLEDGEMENTS

- September 2017: First theory paper.
- July 2018: FASER LOI submitted to LHCC.
- October 2018: **ATLAS SCT** and **LHCb Collaborations** generously agree to let FASER use spare detector tracker and calorimeter modules, respectively.
- November 2018: FASER Technical Proposal submitted to LHCC.
- December 2018: FASER construction fully funded by the **Heising-Simons** and **Simons Foundations**.
- March 2019: FASER approved by **CERN** along with host lab costs.
- December 2019: FASER_v approved by **CERN** along with host lab costs.
- September 2020: FASER_v construction fully funded by **Heising-Simons Foundation**.
- November 2020: FASER installation underground 1st phase completed.
- March 2021: FASER installation underground 2nd phase scheduled.
- Fall 2021: FASER_v installation underground expected.
- Early 2022: FASER and FASER_v begin collecting data with the start of LHC Run 3.

THE FASER COLLABORATION

66 collaborators, 19 institutions, 8 countries

Henso Abreu (Technion), Yoav Afik (Technion), Claire Antel (Geneva), Akitaka Ariga (Bern), Tomoko Ariga (Kyushu/Bern), Florian Bernlochner (Bonn), Tobias Boeckh (Bonn), Jamie Boyd (CERN), Lydia Brenner (CERN), Franck Cadoux (Geneva), Dave Casper (UC Irvine), Charlotte Cavanagh (Liverpool), Xin Chen (Tsinghua), Andrea Coccaro (INFN), Monica D'Onofrio (Liverpool), Candan Dozen (Tsinghua), Yannick Favre (Geneva), Deion Fellers (Oregon), Jonathan Feng (UC Irvine), Didier Ferrere (Geneva), Stephen Gibson (Royal Holloway), Sergio Gonzalez-Sevilla (Geneva), Carl Gwilliam (Liverpool), Shih-Chieh Hsu (Washington), Zhen Hu (Tsinghua), Peppe Iacobucci (Geneva), Sune Jakobsen (CERN), Enrique Kajomovitz (Technion), Felix Kling (SLAC), Umut Kose (CERN), Susanne Kuehn (CERN), Helena Lefebvre (Royal Holloway), Lorne Levinson (Weizmann), Ke Li (Washington), Jinfeng Liu (Tsinghua), Chiara Magliocca (Geneva), Josh McFayden (Sussex), Sam Meehan (CERN), Dimitar Mladenov (CERN), Mitsuhiro Nakamura (Nagoya), Toshiyuki Nakano (Nagoya), Marzio Nessi (CERN), Friedemann Neuhaus (Mainz), Laurie Nevay (Royal Holloway), Hidetoshi Otono (Kyushu), Carlo Pandini (Geneva), Hao Pang (Tsinghua), Brian Petersen (CERN), Francesco Pietropaolo (CERN), Markus Prim (Bonn), Michaela Queitsch-Maitland (CERN), Filippo Resnati (CERN), Jakob Salfeld-Nebgen (CERN), Osamu Sato (Nagoya), Paola Scampoli (Bern), Kristof Schmieden (Mainz), Matthias Schott (Mainz), Anna Sfyrla (Geneva), Savannah Shively (UC Irvine), John Spencer (Washington), Yosuke Takubo (KEK), Ondrej Theiner (Geneva), Eric Torrence (Oregon), Serhan Tufanli (CERN), Benedikt Vormvald (CERN), Di Wang (Tsinghua), Gang Zhang (Tsinghua)



FASER AND FASER_ν DETECTORS

- FASER and FASER_ν are designed to detect charged tracks and neutrinos.
 - 50cm deep trench puts the detectors on axis. Coverage: $\eta > 9$, total length: 6 m.
 - FASER: tracker and calorimeter, detects LLP decay to pair of TeV charged tracks. Background negligible (FLUKA simulations validated by prototype detector in 2018).
 - FASER_ν: emulsion detector, detects CC and NC neutrino interactions.

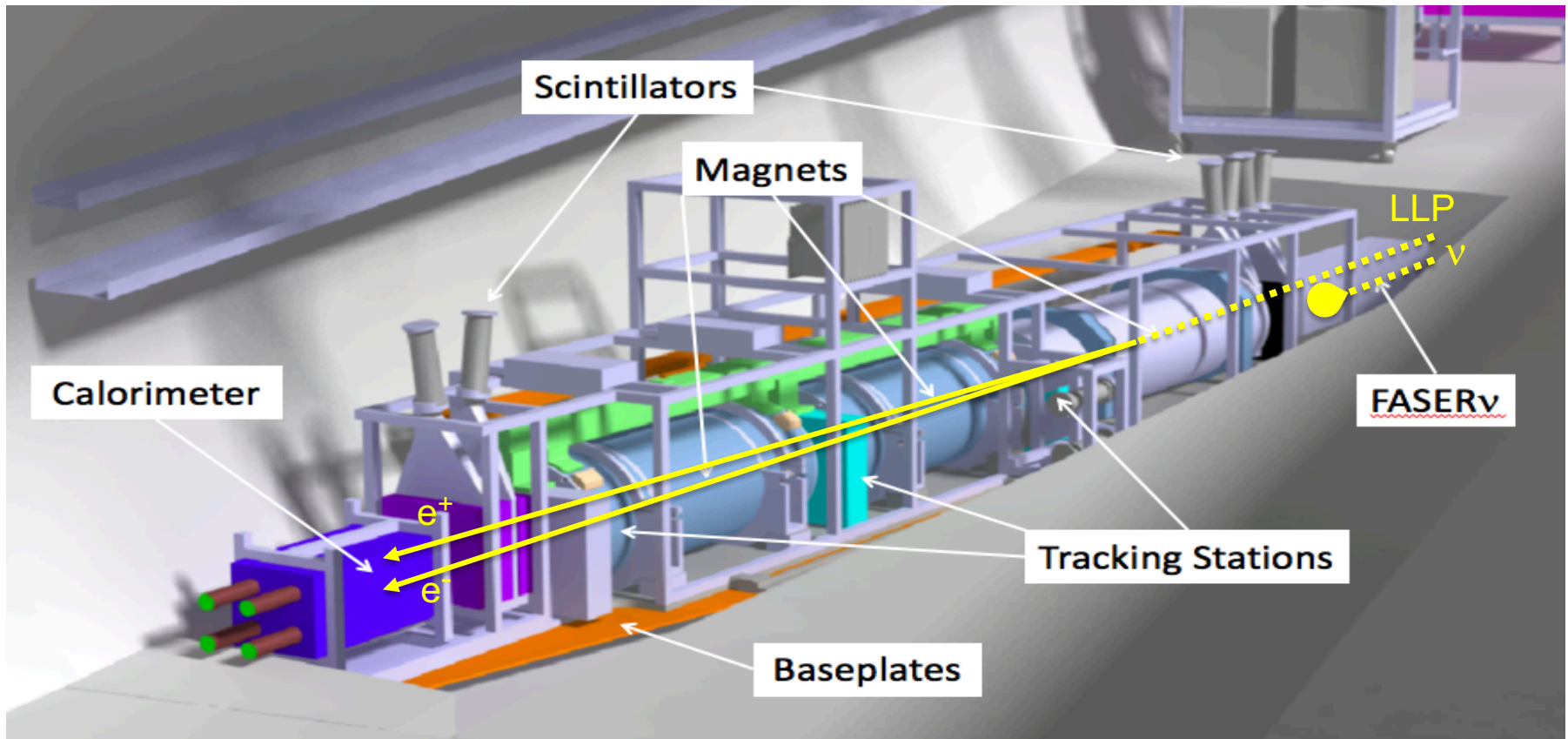

MAGNETS

- FASER includes 3 magnets: 1.5 m, 1 m, and 1m long.
- These magnets have an inner diameter of 20cm, are 0.57 T permanent dipoles, separate oppositely-charged tracks, require little maintenance.
- Constructed by the CERN magnet group.

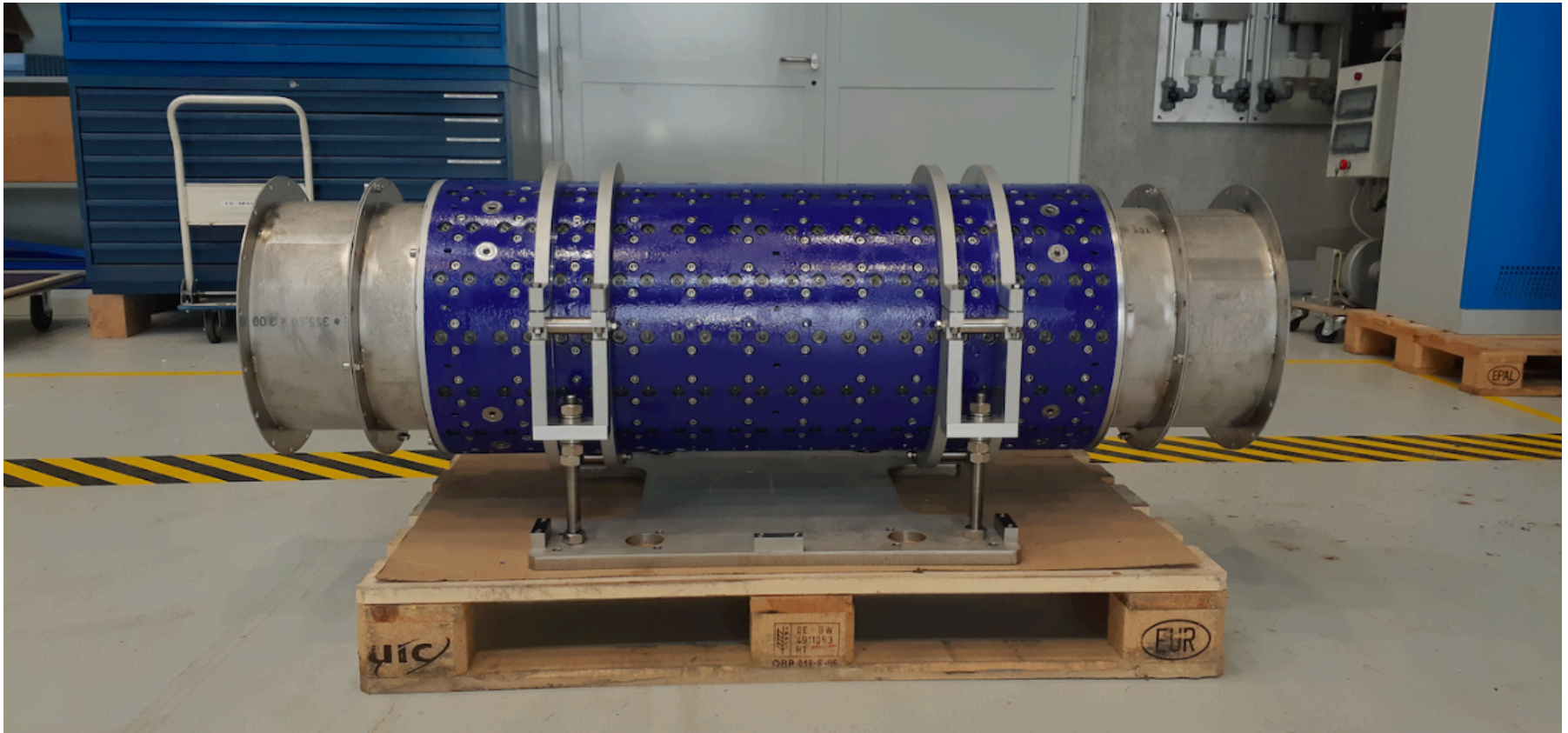

TRACKERS

- 8 ATLAS SCT modules per tracking plane, 3 tracking planes per tracking station, 3 tracking stations at FASER.

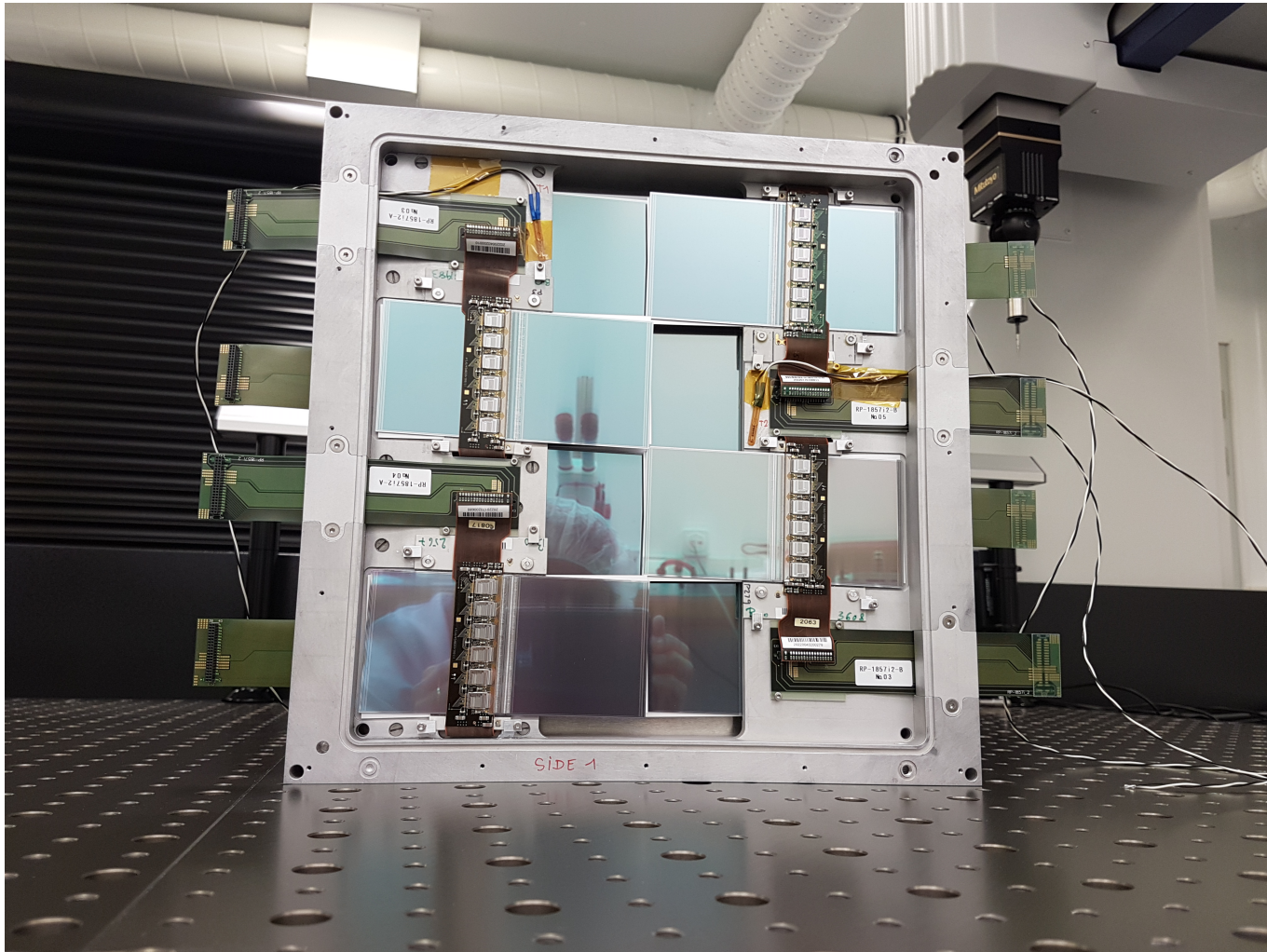

FASER CONSTRUCTION STATUS



FASER INSTALLATION

Dougherty, CERN Integration (2019)

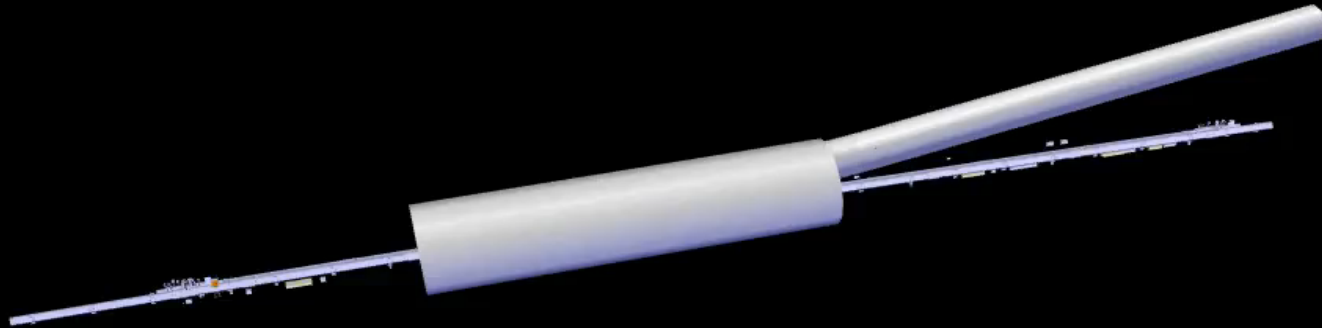

FASER INSTALLATION



FASER INSTALLATION



FASER INSTALLATION



FASER INSTALLATION

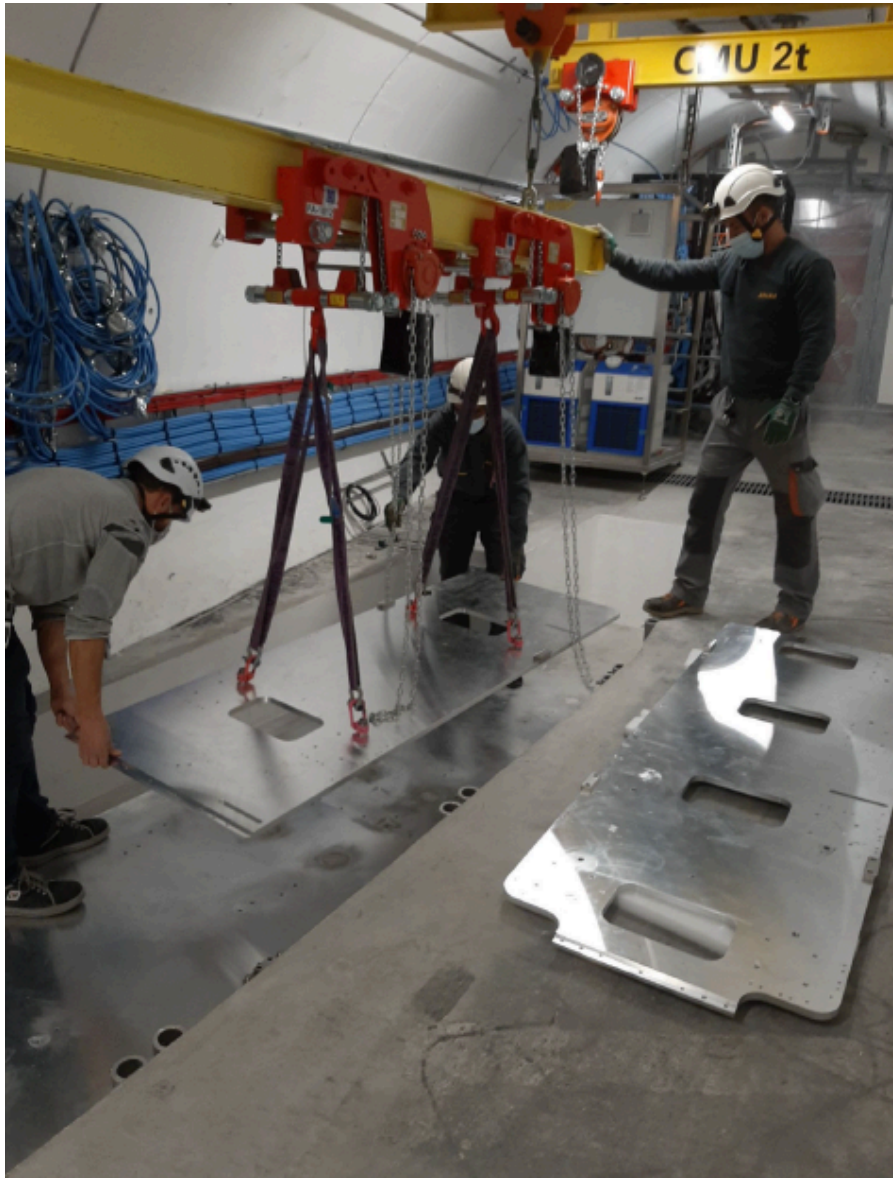

FASER INSTALLATION

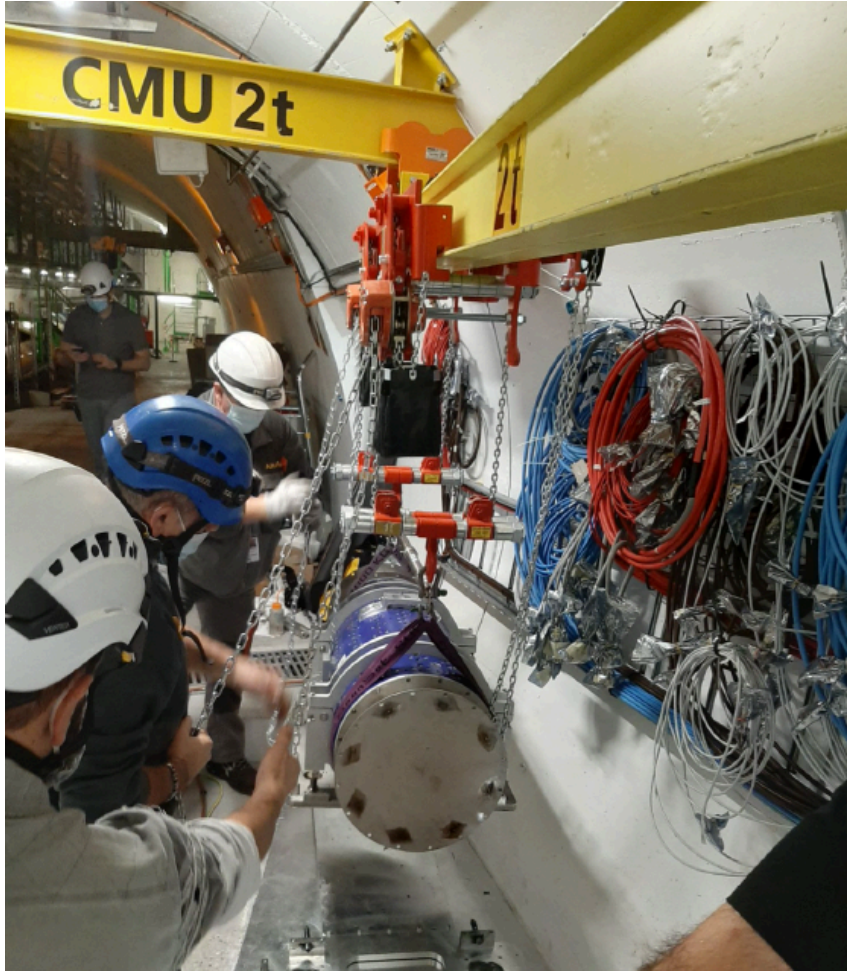

FASER CURRENT STATUS

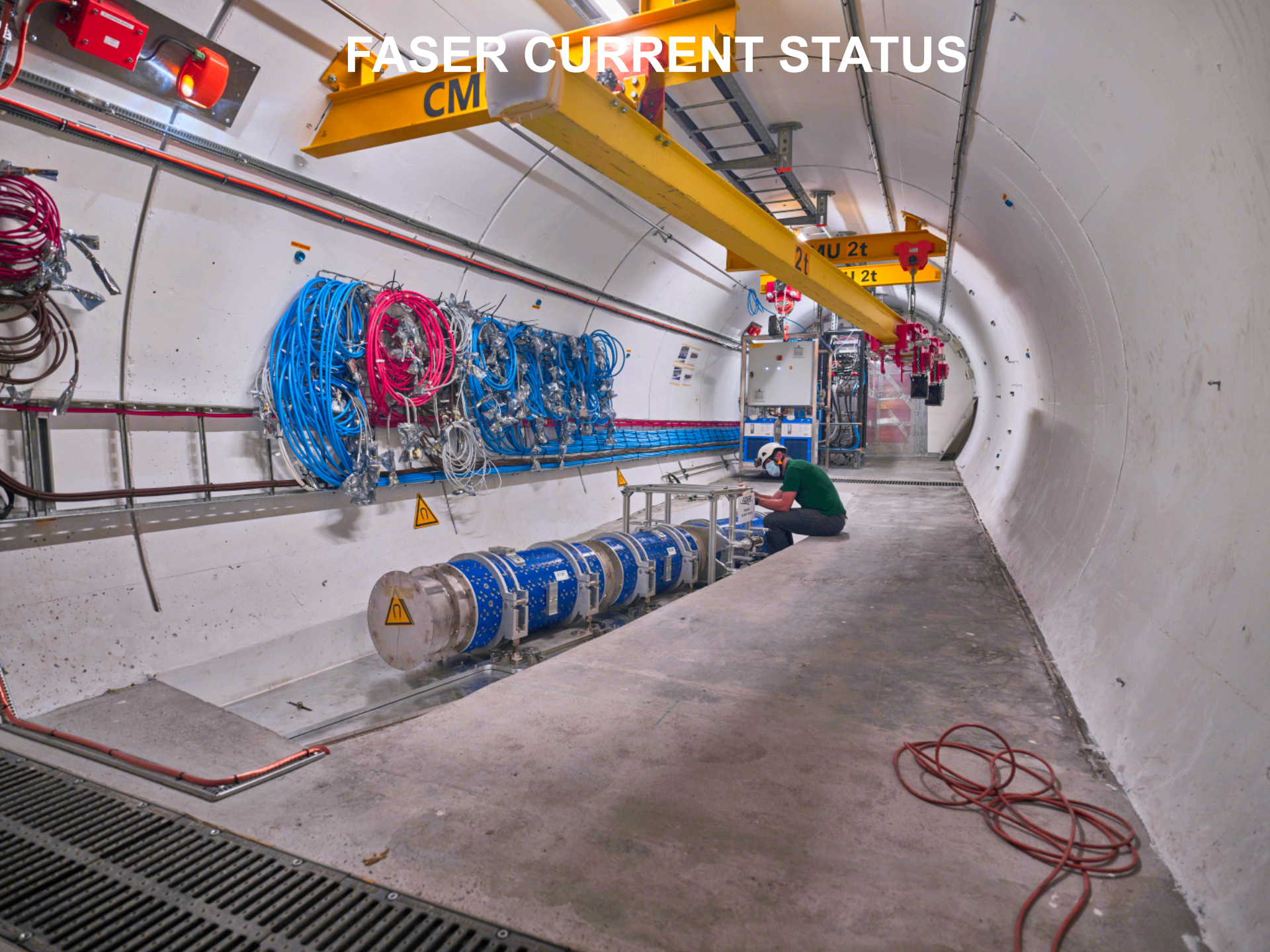

FASER CURRENT STATUS

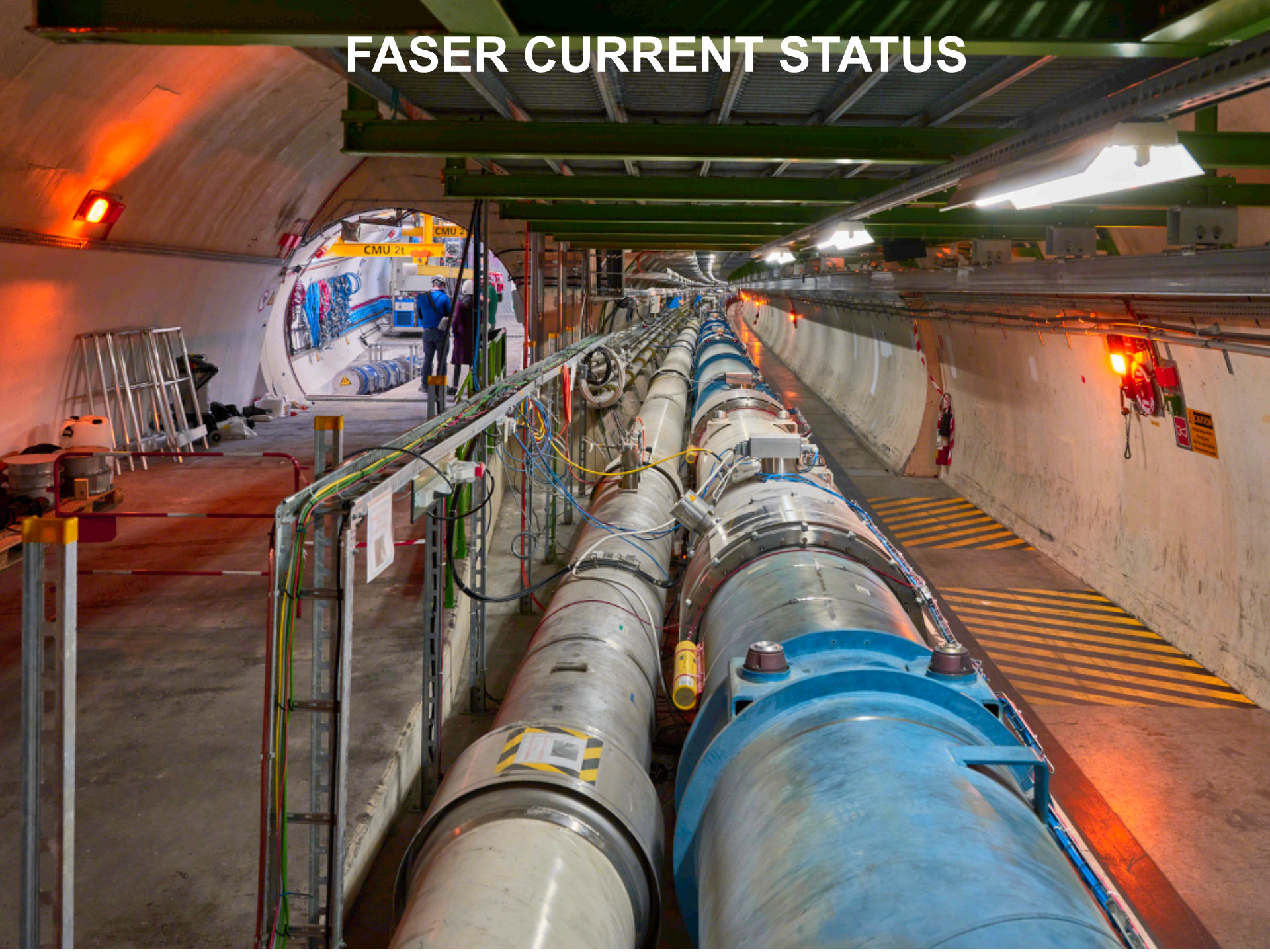

FORWARD PHYSICS FACILITY

FORWARD PHYSICS FACILITY

- FASER, FASER _{ν} , and other proposed detectors are currently highly constrained by tunnels and infrastructure that was never designed to support experiments.
- At the same time, it is becoming clear that there is a rich physics program in the far-forward region, spanning long-lived particle searches, neutrinos, QCD, dark matter, dark sector, cosmic rays, and cosmic neutrinos.
- Strongly motivates enlarging UJ12 (or UJ18) to create a dedicated facility to house several far-forward experiments.

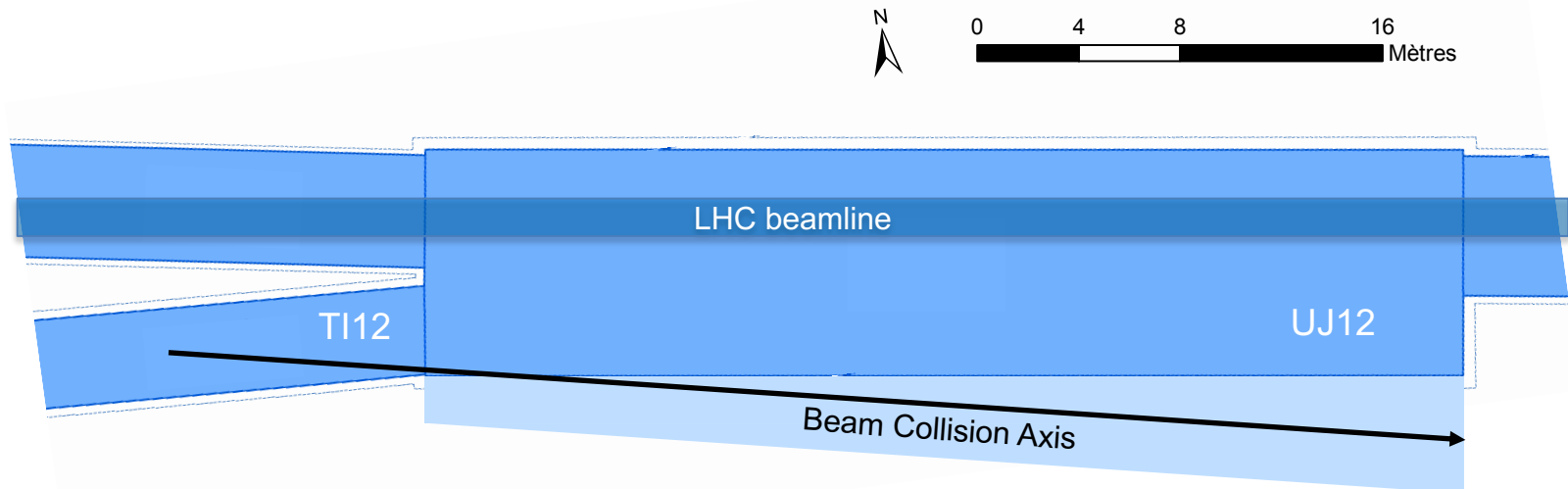

FORWARD PHYSICS FACILITY: SNOWMASS LOI

SNOWMASS 2021 LETTER OF INTEREST

FORWARD PHYSICS FACILITY

- One of 1578 Snowmass LOIs

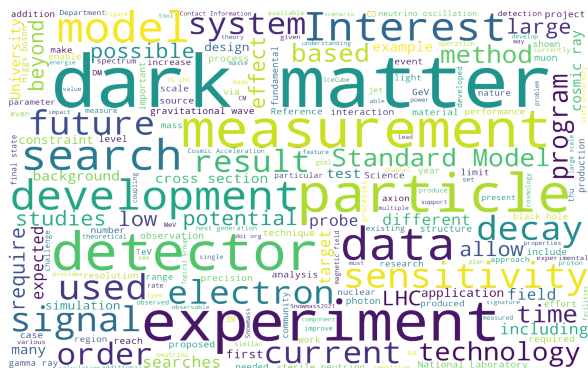

- 240 authors with interest from many communities.

THEMATIC AREAS

- (EF05) QCD and Strong Interactions: Precision QCD
- (EF06) QCD and Strong Interactions: Hadronic Structure and Forward QCD
- (EF09) BSM: More General Explorations
- (EF10) BSM: Dark Matter at Colliders
- (NF03) BSM
- (NF06) Neutrino Interaction Cross Sections
- (NF10) Neutrino Detectors
- (RF06) Dark Sector Studies at High Intensities
- (CF07) Cosmic Probes of Fundamental Physics
- (AF05) Accelerators for PBC and Rare Processes
- (UF01) Underground Facilities for Neutrinos
- (UF02) Underground Facilities for Cosmic Frontier

Roshan M. Abraham,¹ Hensu Abreu,² Yoav Afik,² Sanjib K. Agarwalla,³ Juliette Alimena,⁴ Luis Anchordoqui,⁵ Claire Antel,⁶ Akitaka Ariga,⁷ Tomoko Ariga,⁸ Carlos A. Argüelles,⁹ Kento Asai,¹⁰ Pouya Bakhti,¹¹ Akif B. Balantekin,¹² Victor Baules,¹³ Brian Batell,¹⁴ James Beacham,¹⁵ John F. Beacom,^{4,16,17} Nicole F. Bell,¹⁸ Florian Bernlochner,¹⁹ Atri Bhattacharya,²⁰ Tobias Boeckh,¹⁹ Jamie Boyd,²¹ Lydia Brenner,²¹ Mauricio Bustamante,²² Franck Cadoux,⁶ Mario Campanelli,²³ David W. Casper,²⁴ Grigorios Chachamis,²⁵ Spencer Chang,²⁶ Xin Chen,²⁷ Michael L. Cherry,²⁸ James M. Cline,²⁹ Ruben Conceição,³⁰ Andreas Crivellin,²¹ Matthew Citron,³¹ Andrea Coccaro,³² Yanou Cui,³³ Mohamed R. Darwish,³⁴ Carlos P. de los Heros,³⁵ Patrick deNiverville,³⁶ Peter B. Denton,³⁷ Albert De Roeck,²¹ Frank F. Deppisch,²³ Jordy de Vries,³⁸ Claudio Dib,³⁹ Caterina Doglioni,⁴⁰ Monica D'Onofrio,⁴¹ Liam Dougherty,²¹ Candan Dozen,²⁷ Marco Drewes,⁴² Bhaskar Dutta,⁴³ Tamer Elkafray,⁴⁴ Sebastian A. R. Ellis,⁴⁵ Rouven Essig,⁴⁶ Glennys R. Farrar,⁴⁷ Yasaman Farzan,¹¹ Yannick Favre,⁶ Anatoli Fedynitch,⁴⁸ Deion Fellers,²⁶ Jonathan L. Feng,^{a,24} Didier Ferrere,⁶ Patrick Foldenauer,⁴⁹ Saeid Foroughi-Abari,⁵⁰ Jonathan Gall,²¹ Iftah Galon,⁵¹ Maria V. Garzelli,⁵² Stefano Giagu,⁵³ Stephen Gibson,⁵⁴ Francesco Giuliani,⁵⁵ Bhawna Gomber,⁵⁶ Victor P. Goncalves,⁵⁷ Sergio Gonzalez-Sevilla,⁶ Yury Gornushkin,⁵⁸ Sumit Ghosh,⁴³ Claire Gwenlan,⁵⁹ Carl Gwilliam,⁴¹ Jan Hajer,⁴² Francis Halzen,^{12,60} Juan Carlos Helo,⁶¹ Christopher S. Hill,⁴ Martin Hirsch,⁶² Samuel D. Homiller,⁴⁶ Matheus Hostert,^{63,64} Shih-Chieh Hsu,⁶⁵ Zhen Hu,²⁷ Pham Q. Hung,⁶⁶ Giuseppe Iacobucci,⁶ Philip Ilten,⁶⁷ Tomohiro Inada,⁴⁸ Hiroyuki Ishida,⁶⁸ Aya Ishihara,⁶⁹ Ahmed Ismail,¹ Ameen Ismail,⁷⁰ Sune Jakobsen,²¹ Yu Seon Jeong,²¹ Yongsoo Jho,⁷¹ Krzysztof Jodkowski,⁷² Enrique Kajomovitz,² Kevin J. Kelly,⁷³ Maxim Yu. Khlopov,^{74,75,76} Valery A. Khoze,⁴⁹ Jongkuk Kim,⁴³ Jongkuk Kim,⁷⁷ Teppi Kitahara,⁷⁸ Felix Kling,^{a,45} Joachim Kopp,^{21,79} Umut Kose,²¹ Piotr Kotko,⁸⁰ John Krizmanic,⁸¹ Susanne Kuehn,²¹ Suchita Kulkarni,⁸² Jason Kumar,⁸³ Alexander Kusenko,⁸⁴ Krzysztof Kutak,⁸⁵ Greg Landsberg,⁸⁶ Luca Lavezzo,⁴ Rebecca K. Leane,⁴⁵ Hye-Sung Lee,⁸⁷ Helena Lefebvre,⁵⁴ Benjamin V. Lehmann,⁸⁸ Lorne Levinson,⁸⁹ Ke Li,⁶⁵ Shirley W. Li,⁴⁵ Shuailong Li,⁹⁰ Benjamin Lillard,⁹¹ Jinfeng Liu,²⁷ Wei Liu,⁹² Zhen Liu,⁹³ Steven Lowette,⁹⁴ Chiara Magliocca,⁶ Brandon Manley,⁴ Danny Marfatia,⁸³ Ioana Maris,⁹⁵ Josh McFayden,²¹ Sam Meehan,²¹ Sascha Mehlhase,⁹⁶ David W. Miller,⁹⁷ Dimitar Mladenov,²¹ Vasiliki A. Mitsou,⁶² Rabindra N. Mohapatra,⁹³ Mitsuhiro Nakamura,⁹⁸ Toshiyuki Nakano,⁹⁸ Marzio Nessi,²¹ Friedemann Neuhaus,⁷⁹ Kenny C. Y. Ng,⁹⁹ Koji Noda,⁴⁸ Satsuki Oda,¹⁰⁰ Nobuchika Okada,¹³ Satomi Okada,¹³ Yasar Onel,¹⁰¹ John Osborne,²¹ Hidetoshi Otono,⁸ Carlo Pandini,⁶ Vishvas Pandey,¹⁰² Hao Pang,²⁷ Silvia Pascoli,⁴⁹ Seong Chan Park,⁷¹ Brian Petersen,²¹ Alexey A. Petrov,¹⁰³ Tanguy Pierog,¹⁰⁴ Francesco Pietropaolo,²¹ James L. Pinfold,¹⁰⁵ Markus Prim,¹⁹ Michaela Queitsch-Maitland,²¹ Meshkat Rajae,¹¹ Digesh Raut,¹⁰⁶ Federico L. Redi,¹⁰⁷ Peter Reimtz,¹⁰⁸ Mary Hall Reno,¹⁰¹ Filippo Resnati,²¹ Adam Ritz,⁵⁰ Thomas Rizzo,⁴⁵ Tania Robens,¹⁰⁹ Christophe Royon,¹¹⁰ Jakob Salfeld-Nebgen,²¹ Osamu Sato,⁹⁸ Paola Scamporrì,^{7,111} Kristof Schmieden,²¹ Matthias Schott,⁷⁹ Pedro Schwaller,⁷⁹ Manibrata Sen,¹¹² Dipan Sengupta,¹¹³ Anna Sfyrlla,⁶ Qaisar Shafi,¹⁰⁶ Takashi Shimomura,¹¹⁴ Seodong Shin,¹¹⁵ Savannah Shively,²⁴ Ian M. Shoemaker,¹¹⁶ Carlos V. Sierra,¹¹⁷ Torbjörn Sjöstrand,¹¹⁸ Yotam Soreq,² Huayang Song,⁹⁰ Jordan Smolinsky,¹⁰² John Spencer,⁶⁵ David Stuart,³¹ Shufang Su,⁹⁰ Wei Su,¹¹⁹ Antoni Szczurek,^{120,121} Dai-suke Takahashi,¹⁰⁰ Yosuke Takubo,¹²² Ondřej Theiner,⁶ Serap Tilav,¹⁰⁶ Charles Timmermans,^{117,123} Eric Torrence,²⁶ Sebastian Trojanowski,¹²⁴ Yu-Dai Tsai,⁷³ Serhan Tufanli,²¹ Paolo Valente,¹²⁵ Benedikt Vormwald,²¹ Carlos E. M. Wagner,^{97,126} Di Wang,²⁷ Zeren S. Wang,¹²⁷ Tao Xu,¹²⁸ Tianlu Yuan,^{12,60} Tevong You,²¹ Shigeru Yoshida,⁶⁹ Dengfeng Zhang,²⁷ Gang Zhang,²⁷ Yue Zhang,¹²⁹ and Yi-Ming Zhong,¹³⁰

^a Contact Information: Jonathan L. Feng (jlf@uci.edu), Felix Kling (felixk@slac.stanford.edu)

FPF KICKOFF MEETING

- The FPF Kickoff Meeting was held on 9-10 November 2020.
- 40 talks, lots of fascinating discussion, brought together people studying dark matter, dark sectors, LLPs, milli-charged particles, MC event generators, QCD, neutrinos, and cosmic ray and cosmic neutrino physics.
- For talk slides and Zoom recordings, see <https://indico.cern.ch/event/955956>.

The screenshot shows the Indico event page for the "Forward Physics Facility - Kickoff Meeting" held on 9-10 November 2020. The page features a navigation menu on the left with options like Overview, Scientific Programme, Call for Abstracts, Timetable (selected), Contribution List, Registration, Book of Abstracts, Participant List, and Author List. Below the menu, the names and contact information of the organizers (Jonathan Lee Feng, Maria Vittoria Garzelli, and Felix Kling) are listed. The main content area displays the "Timetable" for Monday, 9/11, with a search bar and navigation controls. The schedule includes sessions such as "FPF Overview" by Jonathan Lee Feng (16:00-16:15), "FPF Civil Engineering: Initial Study" by Jonathan Gall (16:20-16:40), and "Infrastructure Requirements and Particle Fluxes and Environment" by Jamie Boyd (16:45-17:05), followed by a "Discussion / Coffee Break" (17:10-17:20).

Forward Physics Facility - Kickoff Meeting

9-10 November 2020
Europe/Zurich timezone

Search...

Overview
Scientific Programme
Call for Abstracts
Timetable
Contribution List
Registration
Book of Abstracts
Participant List
Author List

Jonathan Lee Feng, Maria Vittoria Garzelli, Felix Kling

jlf@uci.edu
maria.vittoria.garzelli@d...
fixkling@gmail.com

Timetable

< Mon 09/11 Tue 10/11 All days >

Print PDF Full screen Detailed view Filter
Session legend

Mon 9/11

16:00	FPF Overview	Jonathan Lee Feng	16:00 - 16:15
	FPF Civil Engineering: Initial Study	Jonathan Gall	16:20 - 16:40
	Infrastructure Requirements and Particle Fluxes and Environment	Jamie Boyd	16:45 - 17:05
17:00	Discussion / Coffee Break		17:10 - 17:20

NEW PHYSICS SEARCHES AT THE FPF

- FASER 2, an upgraded FASER with $R = 1$ m, $L = 10$ m, can discover all candidates with renormalizable couplings (dark photon, dark Higgs, HNL); ALPs with all types of couplings (γ , f , g); and many other particles.
- Among the PBC benchmark scenarios, FASER2's discovery potential extends to all benchmark scenarios, except BC2 and BC3.

Benchmark Model	FASER	FASER 2
BC1: Dark Photon	√	√
BC1': $U(1)_{B-L}$ Gauge Boson	√	√
BC2: Invisible Dark Photon	–	–
BC3: Milli-Charged Particle	–	–
BC4: Dark Higgs Boson	–	√
BC5: Dark Higgs with hSS	–	√
BC6: HNL with e	–	√
BC7: HNL with μ	–	√
BC8: HNL with τ	√	√
BC9: ALP with photon	√	√
BC10: ALP with fermion	√	√
BC11: ALP with gluon	√	√

BC2: INVISIBLE DARK PHOTONS AT THE FPF

- If $m_{\text{LLP}} > 2m_{\text{DM}}$, the LLP will typically decay in the dark sector to dark matter, leading to invisible decays.
- Can look for the resulting DM to scatter off electrons at FASERv 2 or in a LArTPC. Dominant background from neutrinos reduced for $1 < E_e < 20$ GeV.

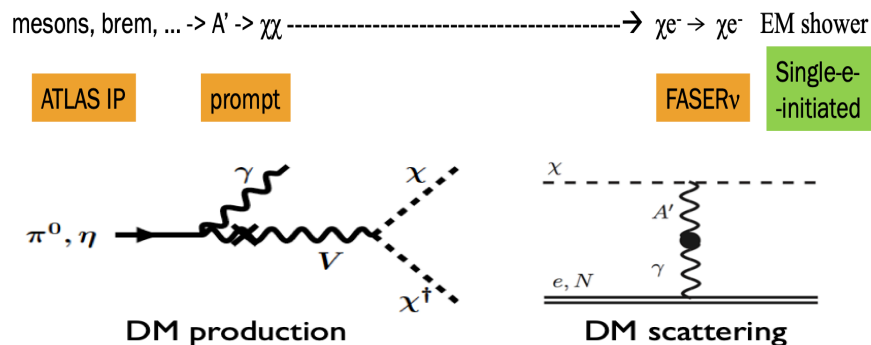

- FASERv2 will probe relic target region. Complementary to dedicated missing energy experiments (e.g., LDMX), which are more sensitive (probe farther into the “too large $\Omega_\chi h^2$ ” region), but don’t detect DM scattering.

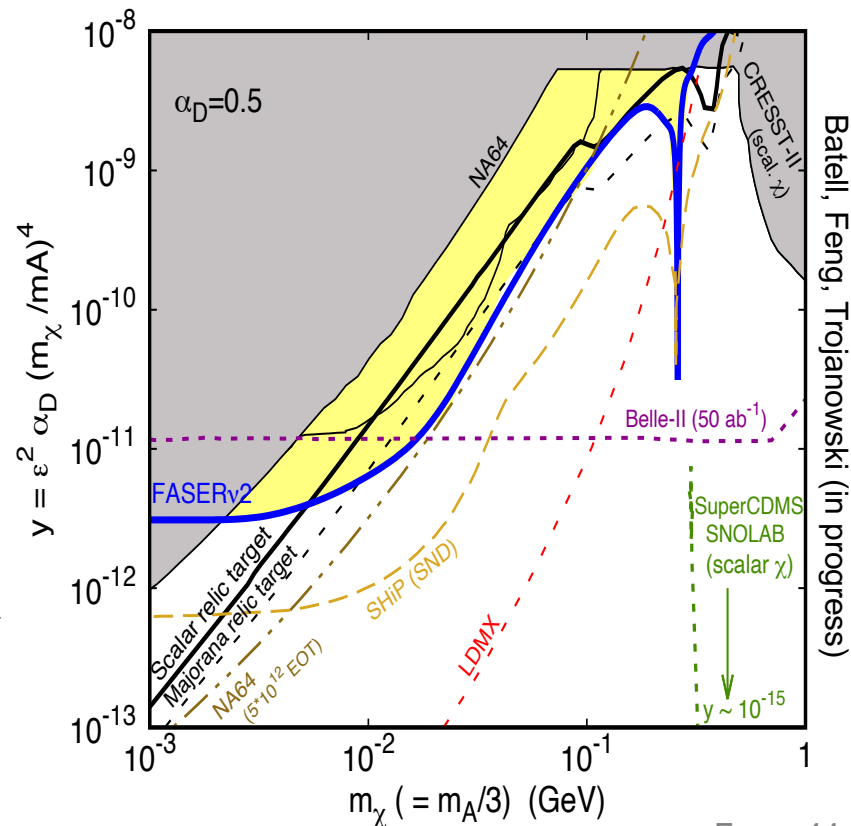

BC3: MILLICHARGED PARTICLES AT THE FPF

- Currently the target of the MilliQan experiment near the CMS IP.
- MilliQan Demonstrator (Proto-MilliQan) already probes new region. Full MilliQan planned to run in this location at HL-LHC, but the sensitivity can be improved greatly by moving it to the FPF (FORMOSA).

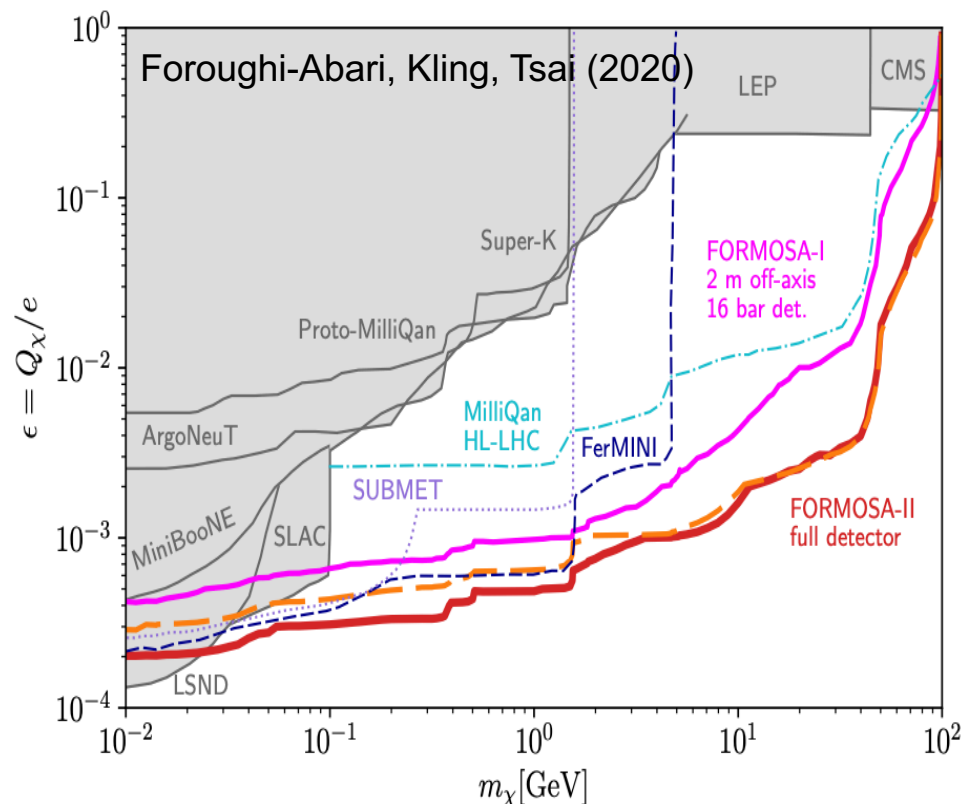

FORWARD PHYSICS FACILITY

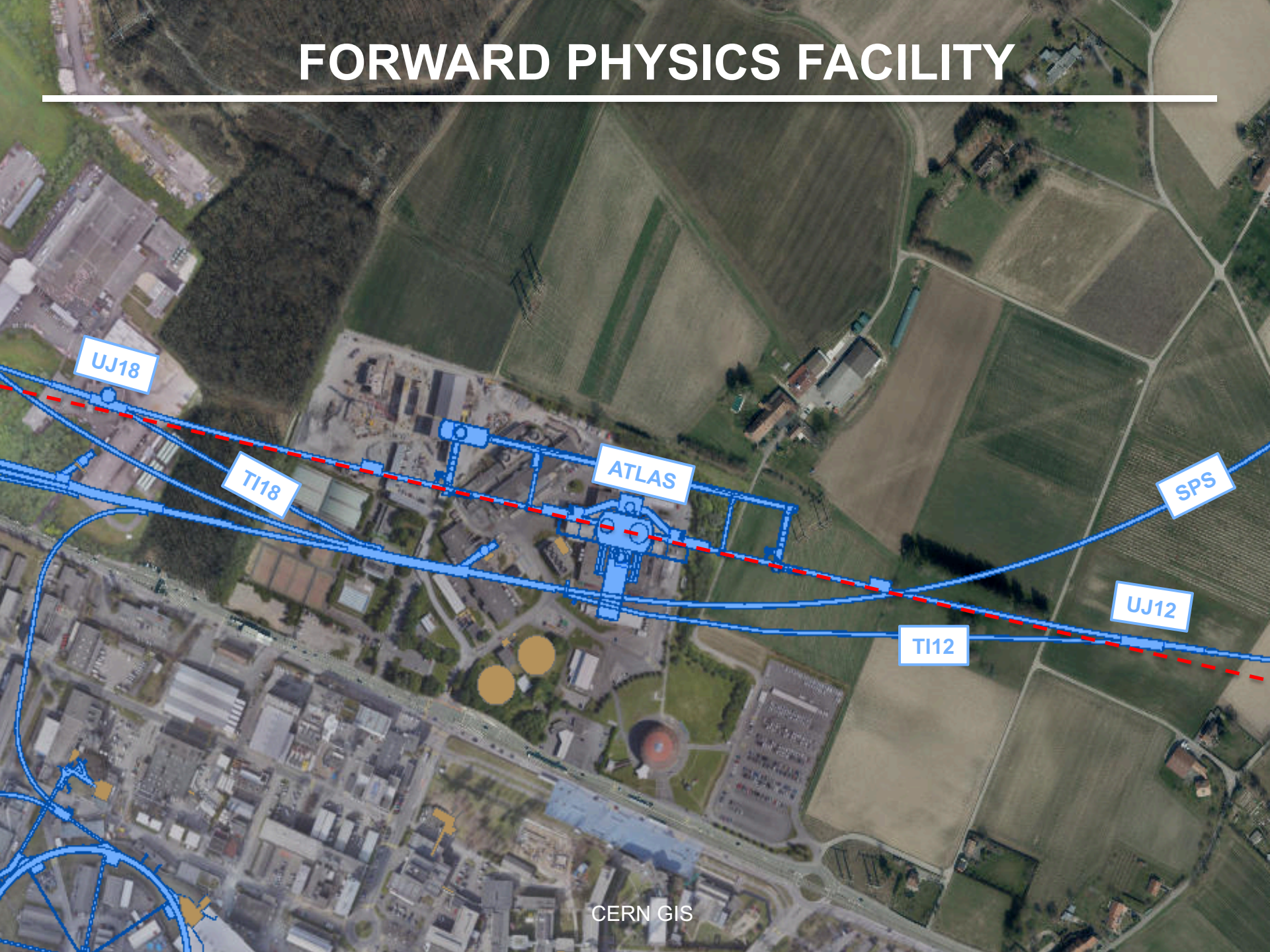

UJ12: POSSIBLE SITE OF THE FPF

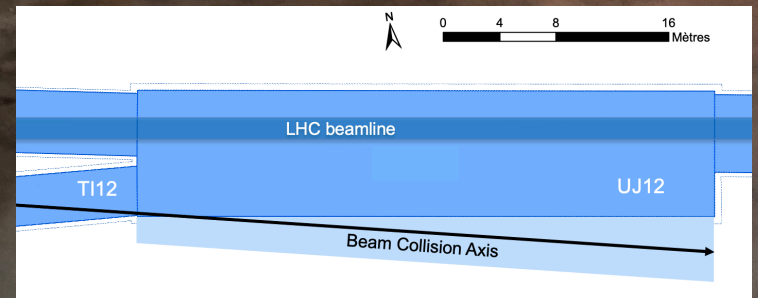
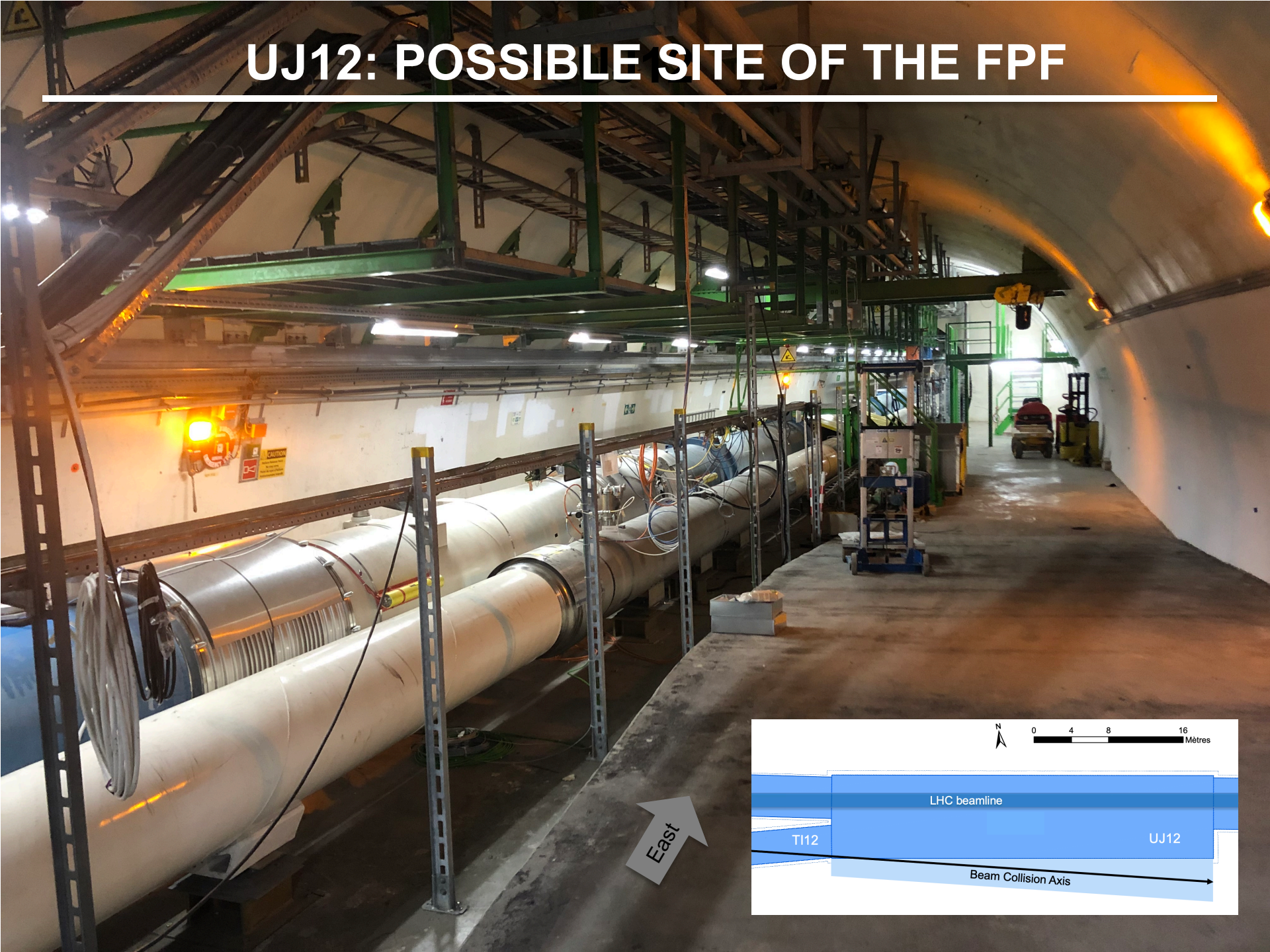

Option 1.1

Demolition/ widening

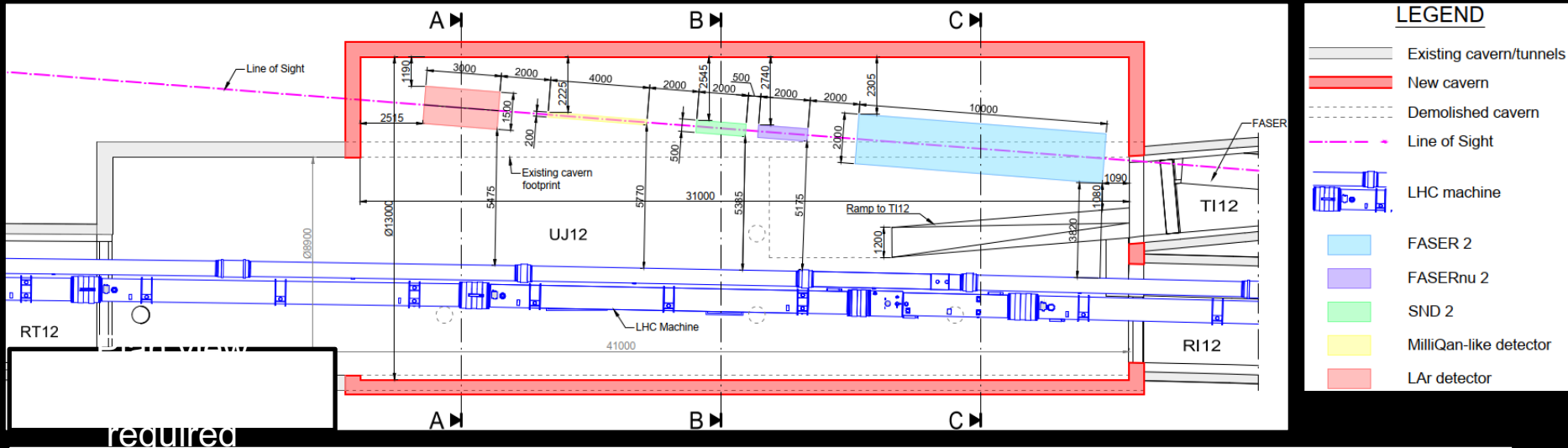

LEGEND

- Existing cavern/tunnels
- New cavern
- Demolished cavern
- Line of Sight
- LHC machine
- FASER 2
- FASERnu 2
- SND 2
- MilliQan-like detector
- LAr detector

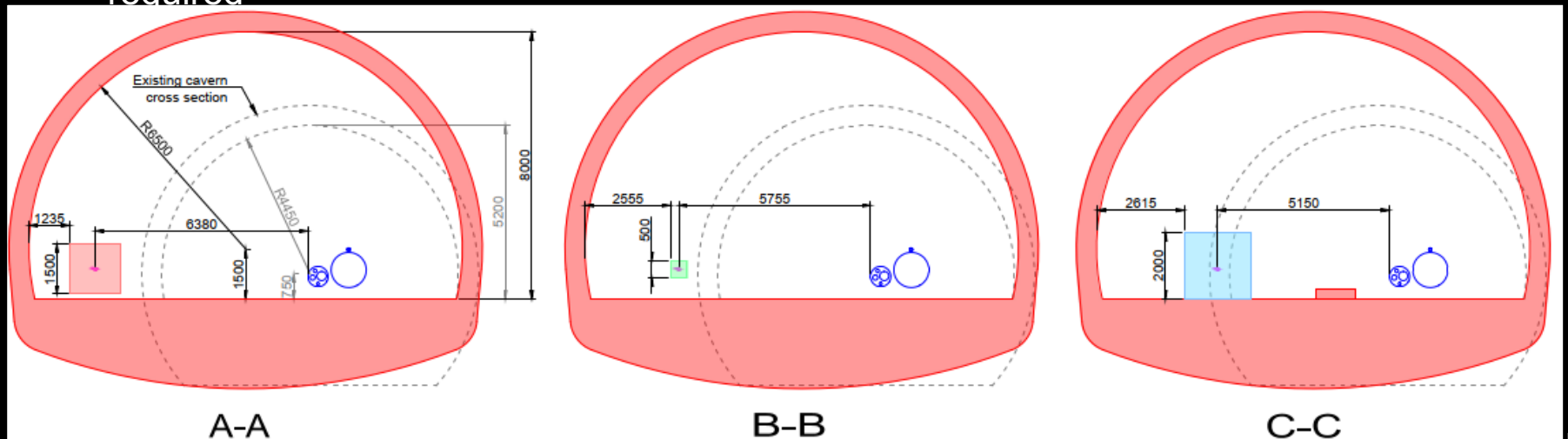



Option 1.2

Widening plus alcoves

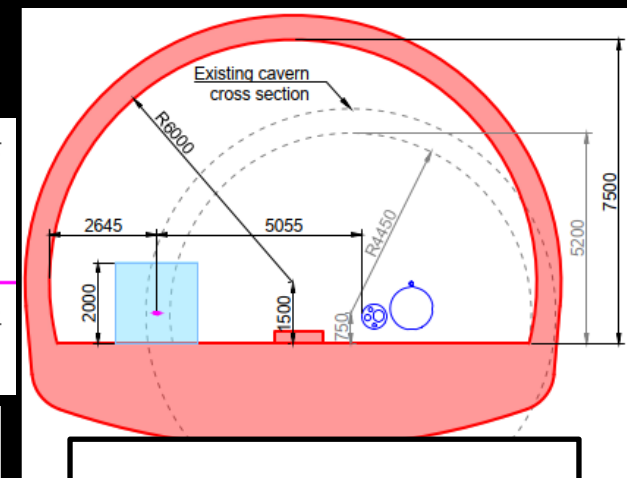
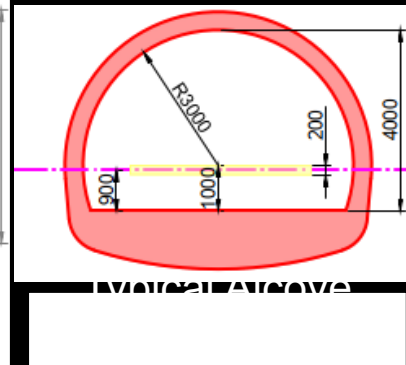
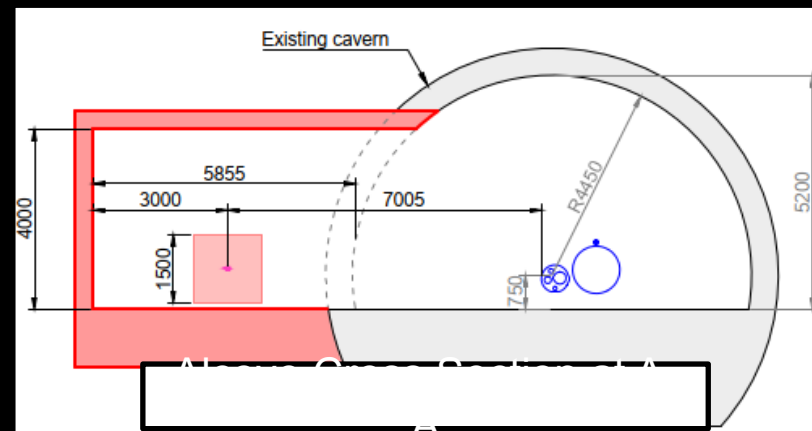
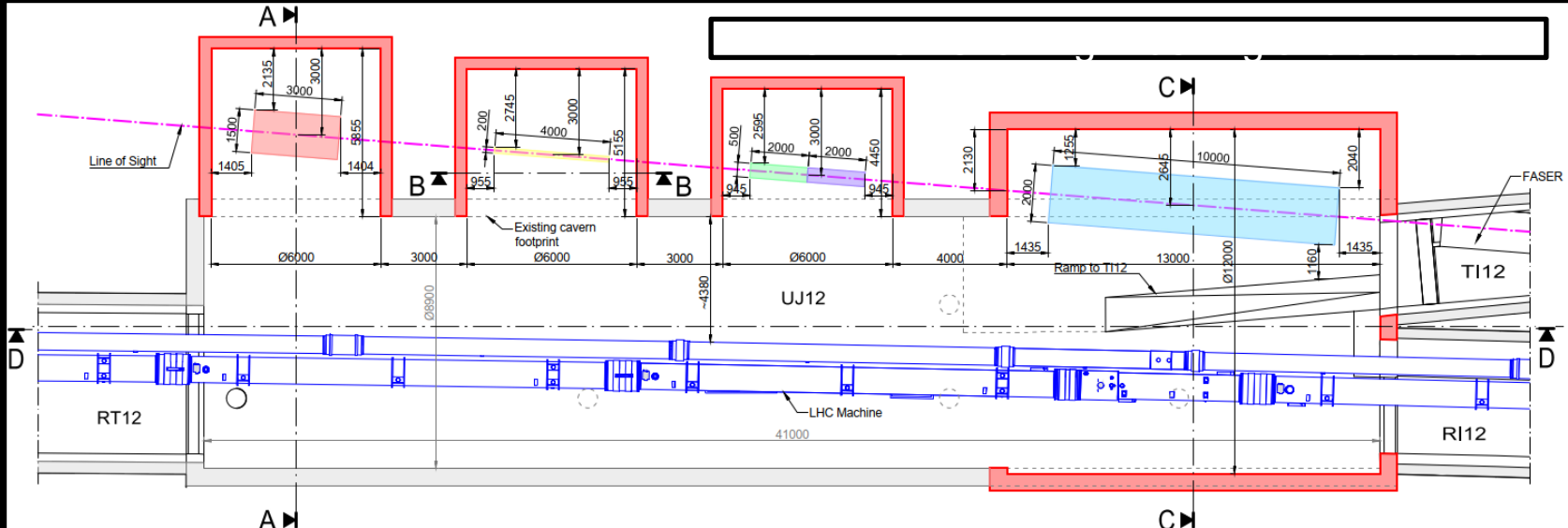



New shaft to consider

Siting for new shaft to consider

- Distance from LoS and LHC
- Land ownership
- Switzerland/ France
- Geology

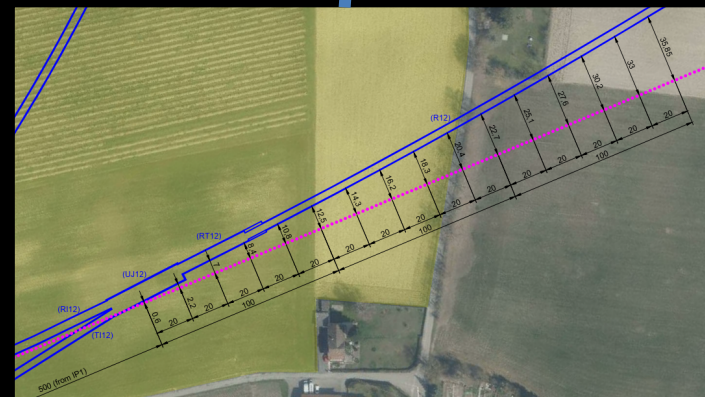
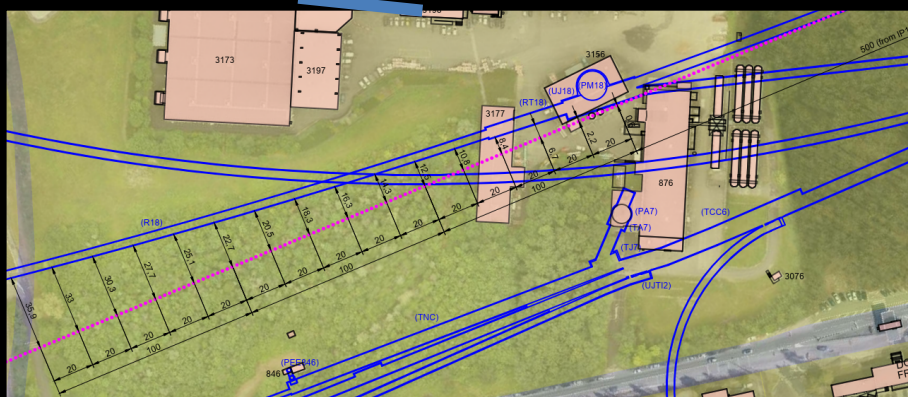
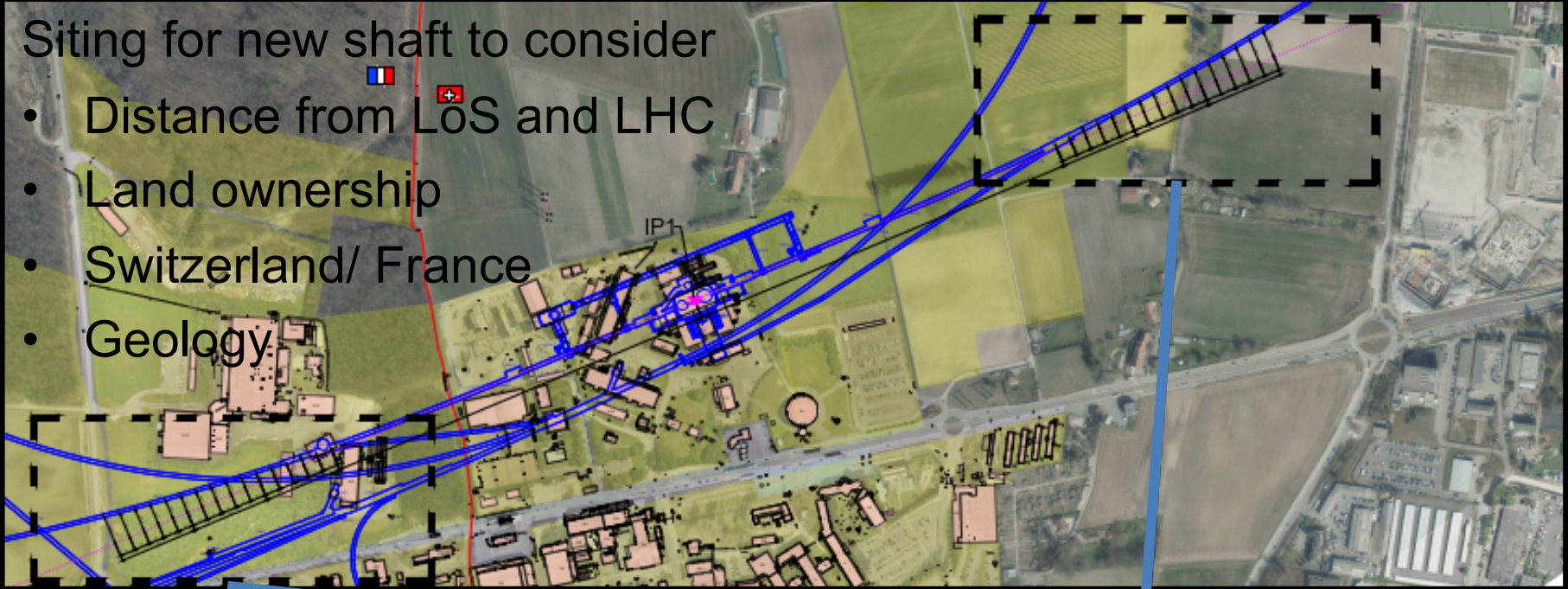

SUMMARY

- The far forward region at the LHC contains a rich physics program that has been underappreciated for decades.
 - BSM: searches for dark matter, dark photons, dark Higgs bosons, HNLs, ALPs, milli-charged particles, new gauge bosons, ...
 - SM: guaranteed discovery of the first collider neutrino, $\sim 1000 \nu_e$, $\sim 10,000 \nu_\mu$, $\sim 10 \nu_\tau$ at TeV energies where there are no or little existing measurements. Implications for BSM neutrino properties, forward hadron production, cosmic ray and cosmic neutrino physics.
- New experiments and facilities
 - Current experiments: FASER and FASER ν are under construction, SND proposed, to collect data in LHC Run 3 from 2022-24.
 - Future initiative: the Forward Physics Facility is proposed to house a suite of far-forward experiments for the HL-LHC era from 2027-36.