



Fermilab Accelerator Technology and EIC

Sergey Belomestnykh

EIC Workshop – Promoting Collaboration on the Electron-Ion Collider

7 October 2020

Talk outline

In this talk I would like to briefly describe **three Accelerator Technology areas** where Fermilab can contribute to **Electron-Ion Collider**

- **Superconducting Radio-Frequency** technology
- **Magnet** technology
- **Cryogenic** technology

In each area I will show some **recent R&D achievements** at Fermilab, **contributions to projects** demonstrating our capabilities and try to highlight **relevance to EIC**

Several facilities at Fermilab will become available in coming years

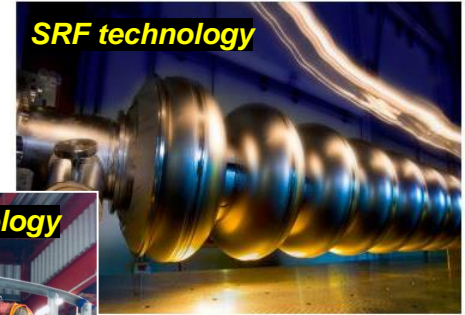

Superconducting RF

SRF at Fermilab: Brief summary

- Fermilab capabilities in SRF include a **complete technological cycle**:

- **RF design** of various cavity shapes (spoke resonators, elliptical cavities, compact crab cavities, SRF guns)
- Developing **innovative cavity treatment** recipes to increase cavity Q and/or gradient specific to project demands
- **Design of cryomodules** and auxiliary components
- Testing for **design verification**, e.g. horizontal teste of fully-dressed cavities
- **Procurement and fabrication** of components
- **Component preparation**, e.g. cavity treatment (EP/BCP, HPR at FNAL and joint ANL/FNAL facility; doping/baking at FNAL), **and testing**, e.g. vertical cavity testing, FPC testing
- **Cryomodule assembly**: two large clean room for cavity string assembly, two high-bay cryomodule assembly areas
- **Shipping** cryomodules to final destination

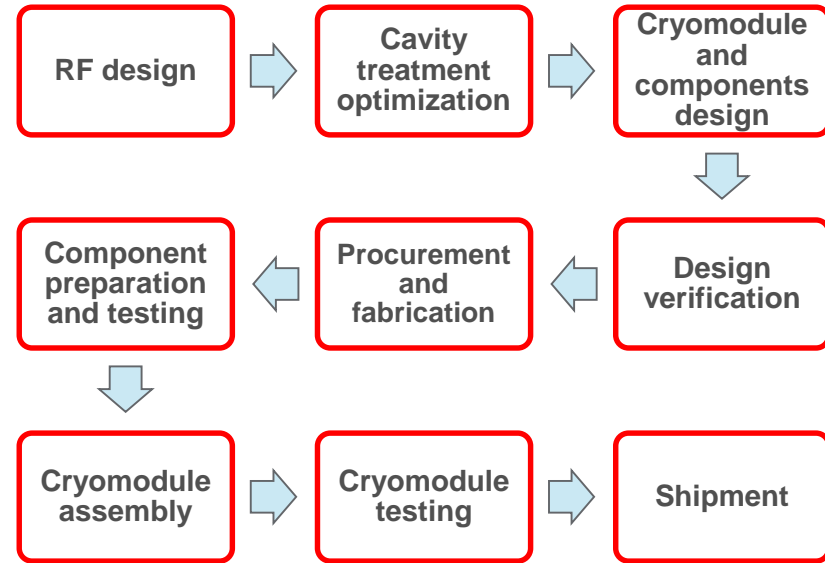

- Current Frontier projects which build upon our SRF facilities + experience include the following:

PIP-II, LCLS-II, LCLS-II-HE, HL-LHC AUP

SRF cavity R&D

- Highlights from **SRF cavity R&D**:
 - Original nitrogen doping recipe – applied to LCLS-II – high Q at ~16 MV/m, 1.3 GHz
 - Modified nitrogen doping for LCLS-II-HE – high Q at ~21 MV/m
 - Nitrogen doping for PIP-II 650 MHz cavities – R&D in progress
 - Breakthrough in understanding oxygen diffusion mechanism for reaching very high gradients – impact to all high gradient cavity applications
 - Medium temperature baking at ~300 C to dissolve oxide and enhance performance of SRF cavities wrt nitrogen doping

Research towards ILC and pulsed SRF linacs

- Present **ILC** spec 31.5 MV/m (per TDR)
- Many new advances in SRF technology since ILC TDR. **New treatments** may **enable significant reduction** in ILC cost: flux expulsion, two-step bake (75/120), cold EP
- This year with ILC Cost Reduction R&D funds from DOE, Fermilab plans to assemble a cryomodule with cavities with new treatments. We would like this to be a collaborative effort (JLAB, Cornell, KEK, ...)
- Goal is to reach higher gradient than has ever been demonstrated in CM test
- Aim will be 38 MV/m average gradient with $Q_0 > 1.0 \times 10^{10}$ and a stretch goal of 40 MV/m
- Achieving this would be a key demonstration of the potential for cost reduction for ILC
- Will reuse CM1, the first SRF cryomodule assembled at Fermilab in 2007



New life of CM1

- The cavities will be replaced by high performing cavities that had achieved ILC specifications and been set aside ~10 years ago for future modules. The cavity will be subjected to the new treatment plan
- Improved magnetic shielding to minimize trapped flux. Encapsulated piezo tuner designs will be used for improved reliability
- Four cavities have been re-treated and tested with max fields:
 - TB9AES011 – 41.3 MV/m (x-rays at max field ~1000 mR/hr)
 - TB9ACC011 – 45.5 MV/m (x-rays at max field ~background)
 - TB9ACC012 – 36.9 MV/m (x-rays at max field ~1 mR/hr)
 - TB9ACC013 – 40.4 MV/m (x-rays at max field ~100 mR/hr)
- Average of 41.0 MV/m

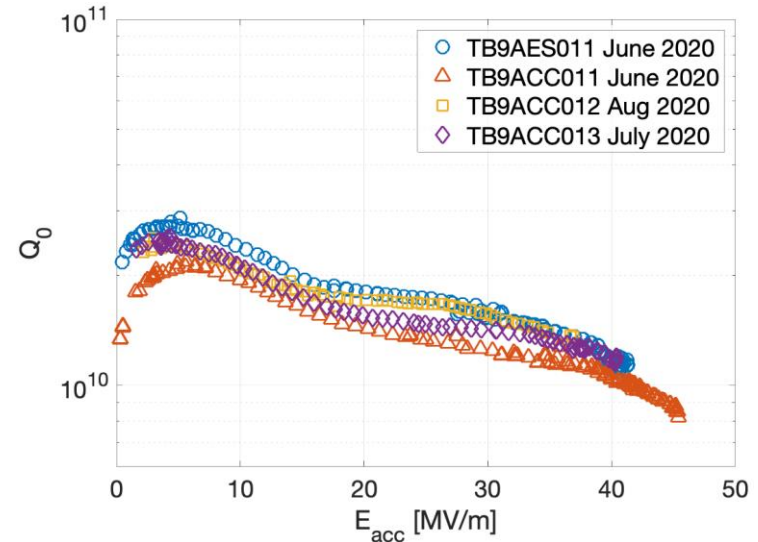

Resonance control of SRF cavities: Frequency tuners

Frequency tuners:

- Developing reliable, inexpensive, simple in installation and maintenance tuner systems
- Collaboration with industry experts to develop (and deploy) extremely reliable active tuner components: stepper motors & piezo actuators

LCLS-II

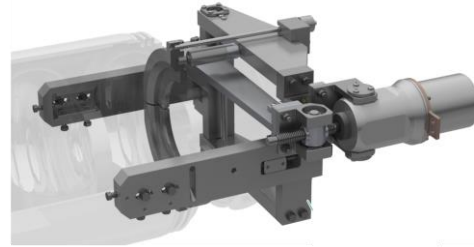

1.3 GHz cavity tuner

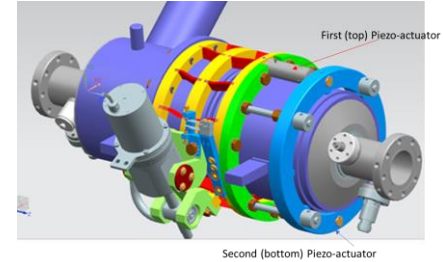

3.9 GHz cavity tuner

PIP-II

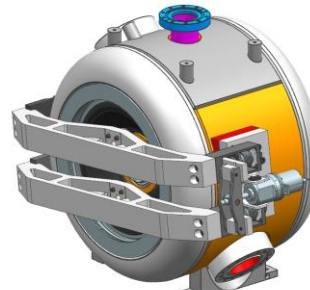

325 MHz SSR1 cavity tuner

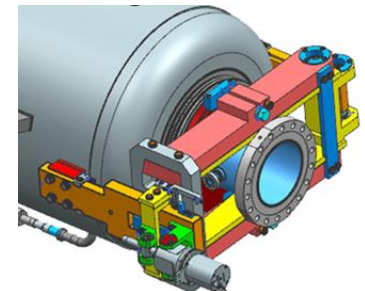

650 MHz cavity tuner



Piezo actuator

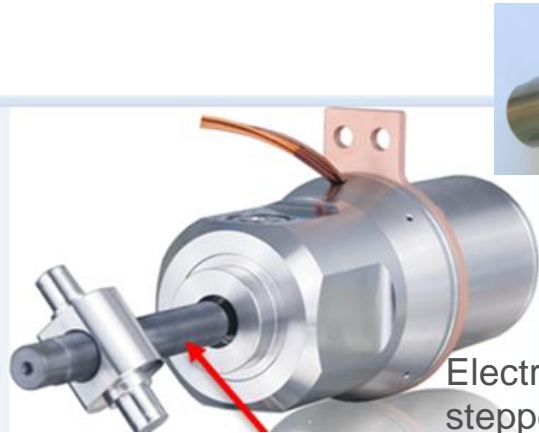

Electromechanical stepper motor actuator

Resonance control of SRF cavities: Active compensation

Active LFD and microphonics compensation:

- Feed-forward Adaptive Least Square algorithm (for pulsed mode of operation), developed during ILC R&D program
- System deployed at FNAL (FAST cryomodules) and during S1Global collaboration
- Microphonics compensation for cavities operating in CW-mode: feedback algorithms for LCLS II Project

1.3 GHz ILC/XFEL pulsed operation

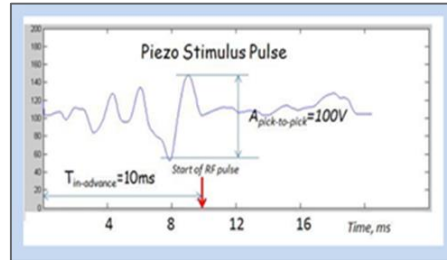
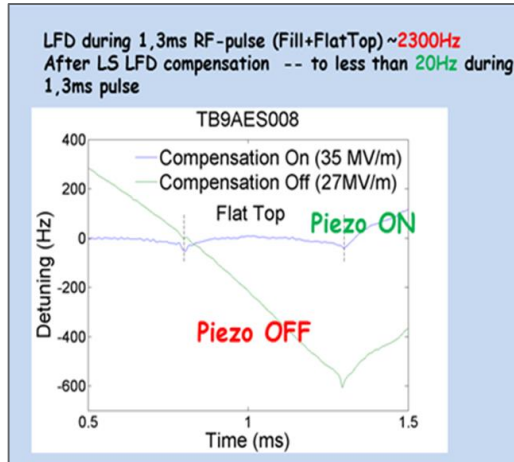

1.3 GHz LCLS-II microphonics suppression

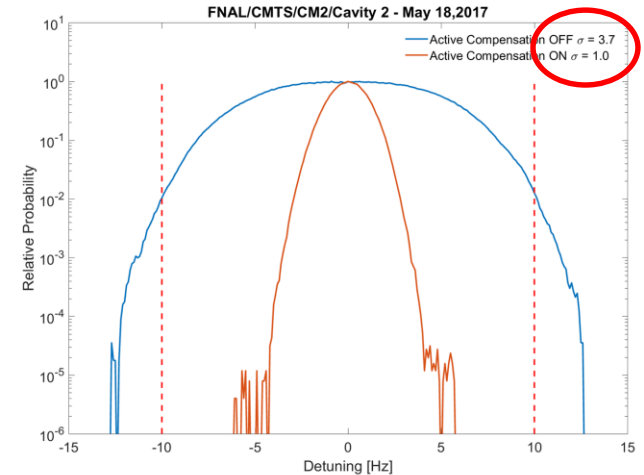

Fundamental power couplers for SRF cavities

Two examples of coaxial FPCs for PIP-II

- for 325 MHz Single Spoke Resonators (**SSR2**): **12 kW CW**, ± 5 kV DC bias, single ceramic disc RF window, 50 K and 5 K heat intercepts, dry-air-cooled antenna

SSR2 FPC assembly

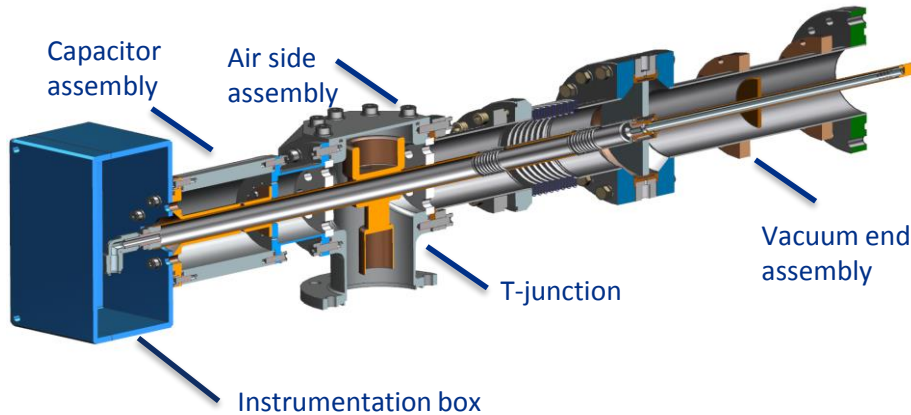

HB650 FPC assembly

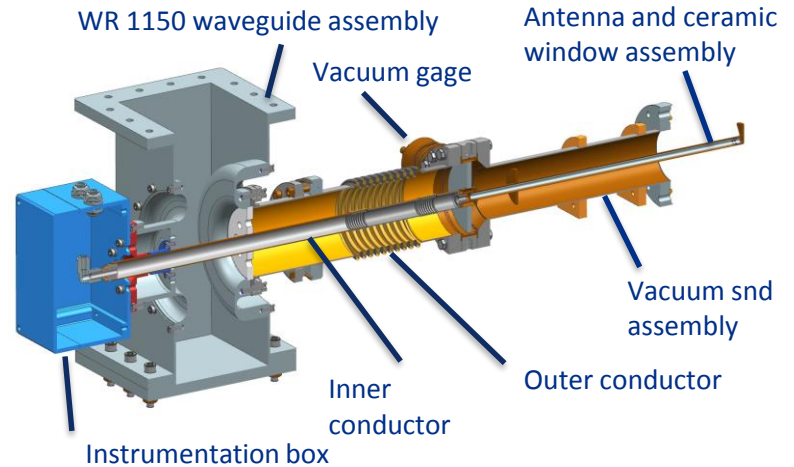

- for High-beta 650 MHz cavities (**HB650**): **50 kW CW**, ± 5 kV DC bias, single ceramic disc RF window, 50 K and 5 K heat intercepts, dry-air-cooled antenna

RFD crab cavities for HL-LHC

- The scope of US HL-LHC Accelerator Upgrade Project (AUP) includes **RF crab cavity design (RF Dipole), fabrication, and qualification**. FNAL is the lead lab with contributions from **SLAC, JLAB, ODU, BNL**
- In particular, this effort includes cavity procurement and processing + cold magnetic shield + helium vessel + HOM couplers + antennas + cold tests
- The dressed cavities will be shipped to **TRIUMF (Canada)** for assembly of 5 cryomodules (with some components coming from CERN) and then cold validation test at **CERN**



Trim-tuning at Zanon
(2020)

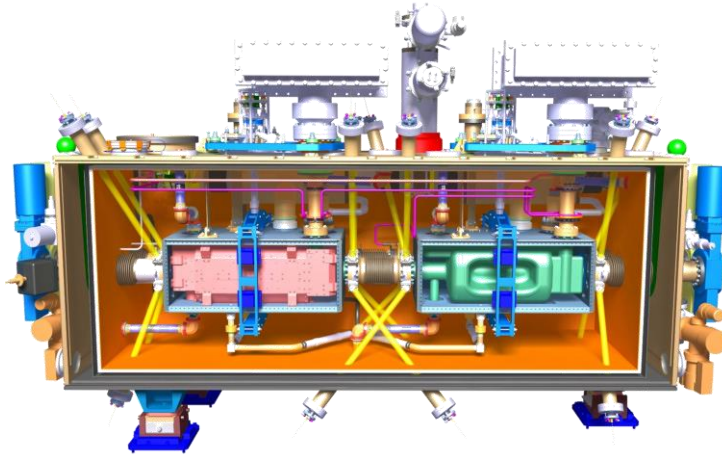

Cryomodule Design (CERN)



Bead-pull measurements at FNAL on
AUP Prototype #1 (Sept 2020)

Facilities for RFD and tests

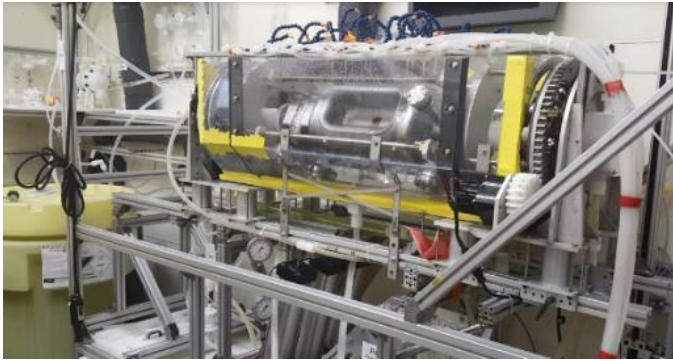

Rotational BCP tool for RFD cavity (ANL/FNAL facility)

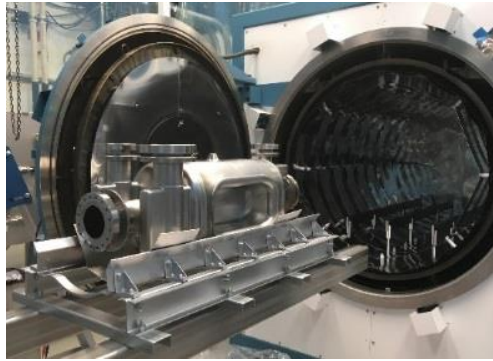

600°C Heat Treatment (FNAL)



120°C Bake (FNAL)



VTS preparation (FNAL)

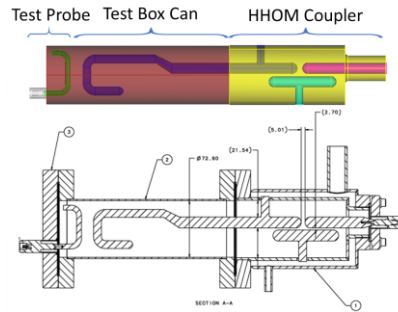
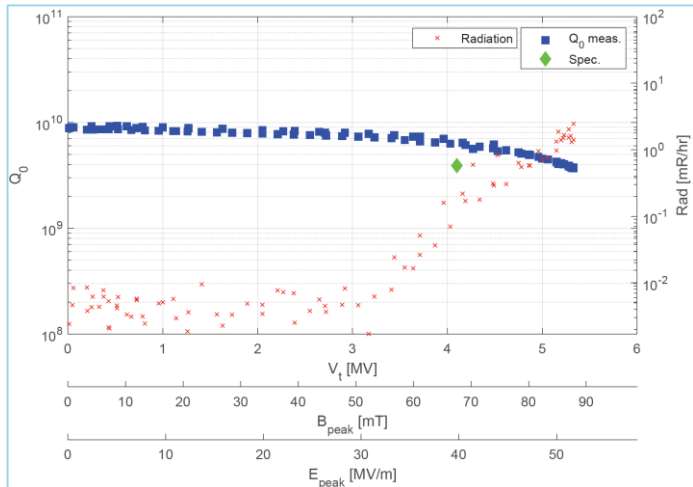

- RFD-LARP-001 exceeded requirements for HL-LHC after processing at **FNAL/ANL**
- AUP successfully qualified RFD crab cavities with both HOM dampers installed

LCLS-II

- LCLS-II was the **first large-scale SRF CM production for Fermilab**
- The scope was to design, build, test and deliver **(17) 1.3 GHz** and **(3) 3.9 GHz CMs**. JLAB is delivering the other ~50% of CMs
- XFEL-like CMs, but operating in CW mode, nitrogen-doped cavities (1.3 GHz)
- **Results exceed specifications**
 - 1.3 GHz energy gain/CM = 158 MV (spec 128 MV), average $Q_0 = 3 \times 10^{10}$ (spec 2.7×10^{10})
 - 3.9 GHz energy gain/CM = 46.5 MV (spec 41 MV), average $Q_0 = 3.45 \times 10^9$ (spec 1.5×10^9)
- Final cryomodule ships to SLAC in February 2021
- Many lessons learned and incorporated during the product run
- **For future projects**
 - When pushing the state of the art for SRF performance, ensure adequate time for R&D, prototyping, qualification of vendors and feedback of initial test results into production
 - When adopting a previous design, pay strict attention to design changes even if deemed to be minor
 - Incorporate transportation requirements into the design process



LCLS-II-HE

- For High-energy upgrade of LCLS-II, LCLS-II-HE, Fermilab will build **one verification CM** and **10+ 1.3 GHz CMs**
 - Same CM design with **minor changes** based on lessons learned
 - New cavity treatment** (2N0 nitrogen doping + cold EP) to reach higher gradient at the same Q_0
 - Successful transfer of protocols to industry**
 - Performance of 10 cavities exceeded specification with average $Q_0 = 3.6 \times 10^{10}$ and $E_{\text{acc}} = 25.6$ MV/m
 - 8 fully dressed cavities are ready for vCM

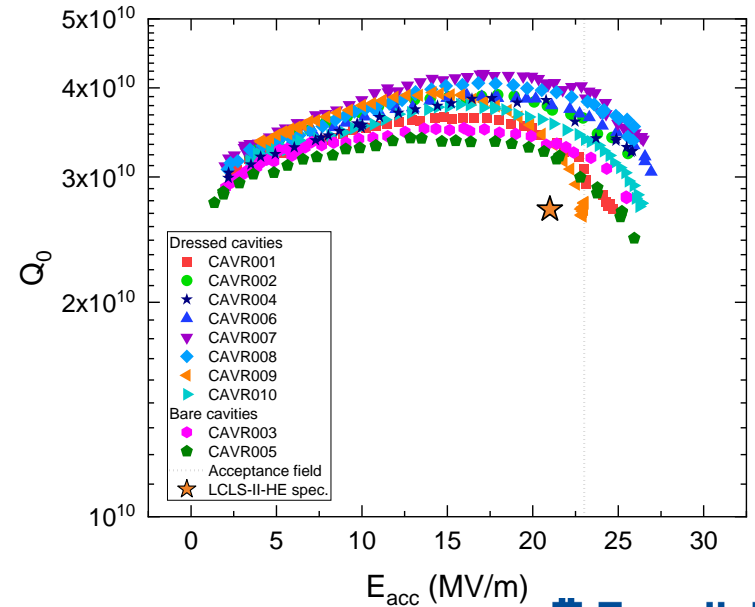

Cryomodule assembly at Fermilab

- The throughput is **one cryomodule per month** (single production line for LCLS-II, limited by cavity availability and CM testing, not assembly)
- After adding **second production line** (already funded), two cryomodule production per month can be achieved
- Some production capacity will be available after CM production for LCLS-II-HE is complete

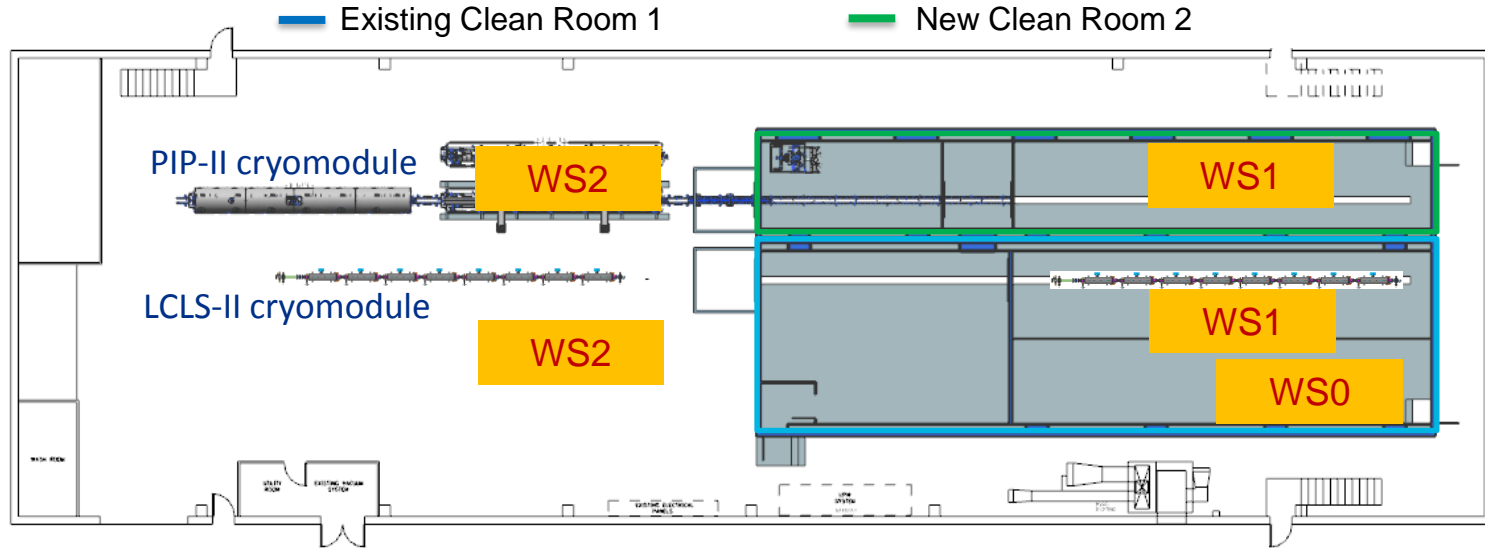

PIP-II superconducting CW linac

- PIP-II linac is technically complex, state of the art superconducting RF accelerator

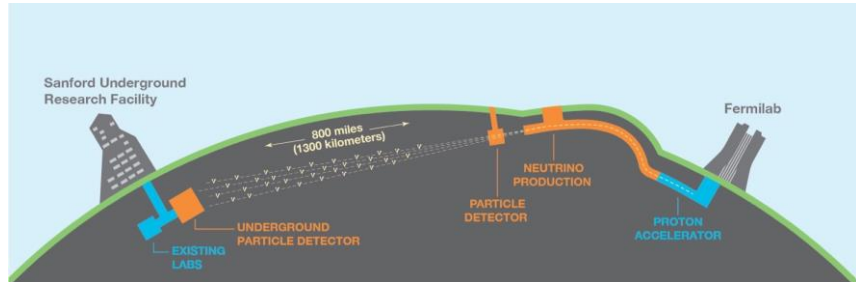
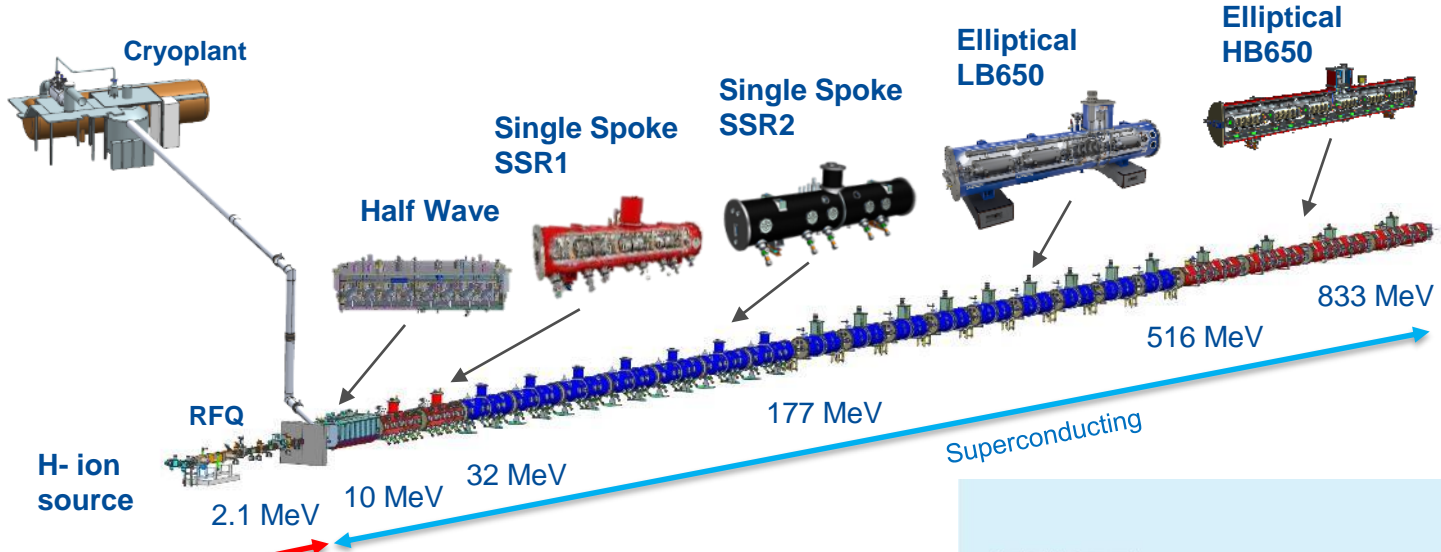

PIP-II cryomodules

- All PIP-II cryomodules are of a strongback type

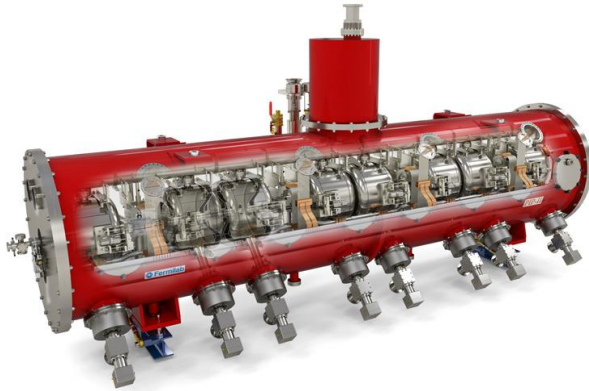

Single Spoke Resonator (SSR1)

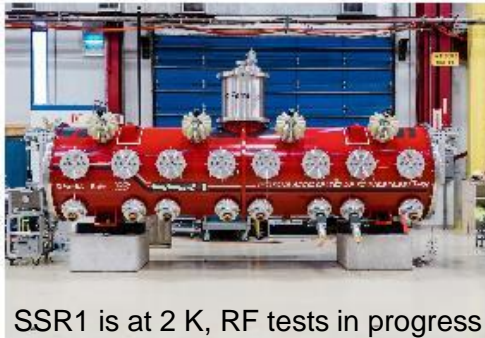

SSR1 is at 2 K, RF tests in progress

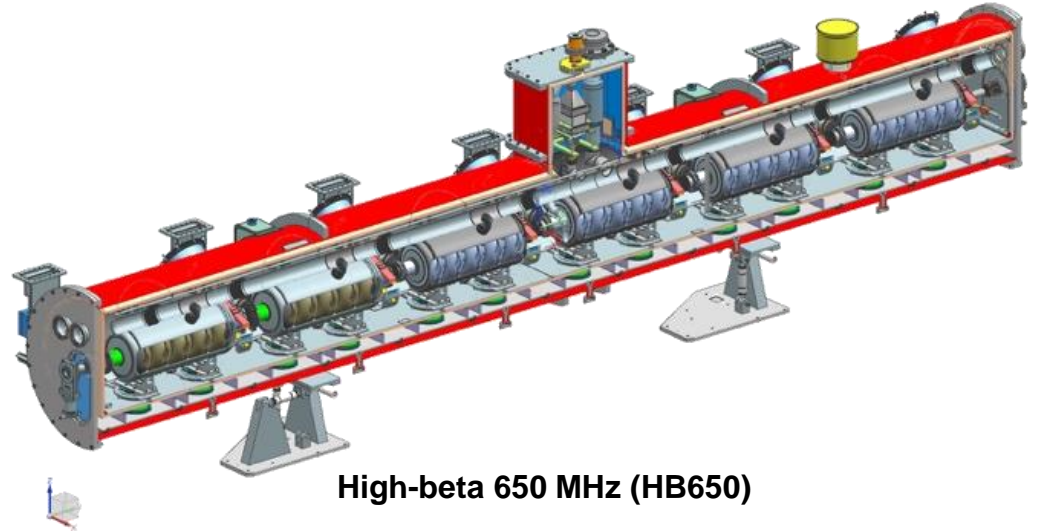

High-beta 650 MHz (HB650)

Summary for SRF

A number of ways Fermilab can potentially contribute to **EIC** in the area of SRF:

- Complete SRF systems for a particular accelerator (pulsed or CW) from design to testing
- Smaller systems, e.g. crab cavities
- Cryomodule procurement and FE-free assembly, experience with different types of cryomodules: ILC/XFEL type (long string of interconnected cryomodules) and segmented cryomodules (strongback design for PIP-II)
- Developing customized cavity treatments
- Developing sub-systems and components, e.g. resonance control and frequency tuners, fundamental power couplers

Magnets

SC magnets at Fermilab

- Fermilab has capability to perform **electromagnetic and mechanical design, manufacture and test** SC magnets for projects and R&D
- **NbTi** (since Tevatron times) and **Nb₃Sn technologies** are readily available, developing **HTS** capabilities
- Examples
 - Projects
 - Q1/Q3 IR quadrupoles for **Hi-Lumi LHC / US HL-LHC Accelerator Upgrade Project (AUP)**
 - **LCLS-II / LCLS-II-HE** SC magnet package (combined quadrupole and two dipole correctors)
 - Solenoids for **Mu2e** experiment
 - **CLAS12** toroidal coils
 - R&D
 - **LARP** quadrupoles
 - **US Magnet Development Program** dipoles
 - **Small conduction-cooled SC HTS magnet magnets** for linacs

US HL-LHC AUP

- US contribution to HL-LHC includes **Q1/Q3 IR quadrupole magnets** (10 cryoassemblies with 2 Nb₃Sn magnets in each)
- **Multi-lab collaborative effort:**
 - Cable fabrication at **LBNL**
 - Coil production at **FNAL and BNL**
 - Magnets are assembled at **LBNL** and vertically tested at **BNL**
 - Cold mass and cryoassembly at **FNAL**
 - Cryoassembly horizontal test at **FNAL**

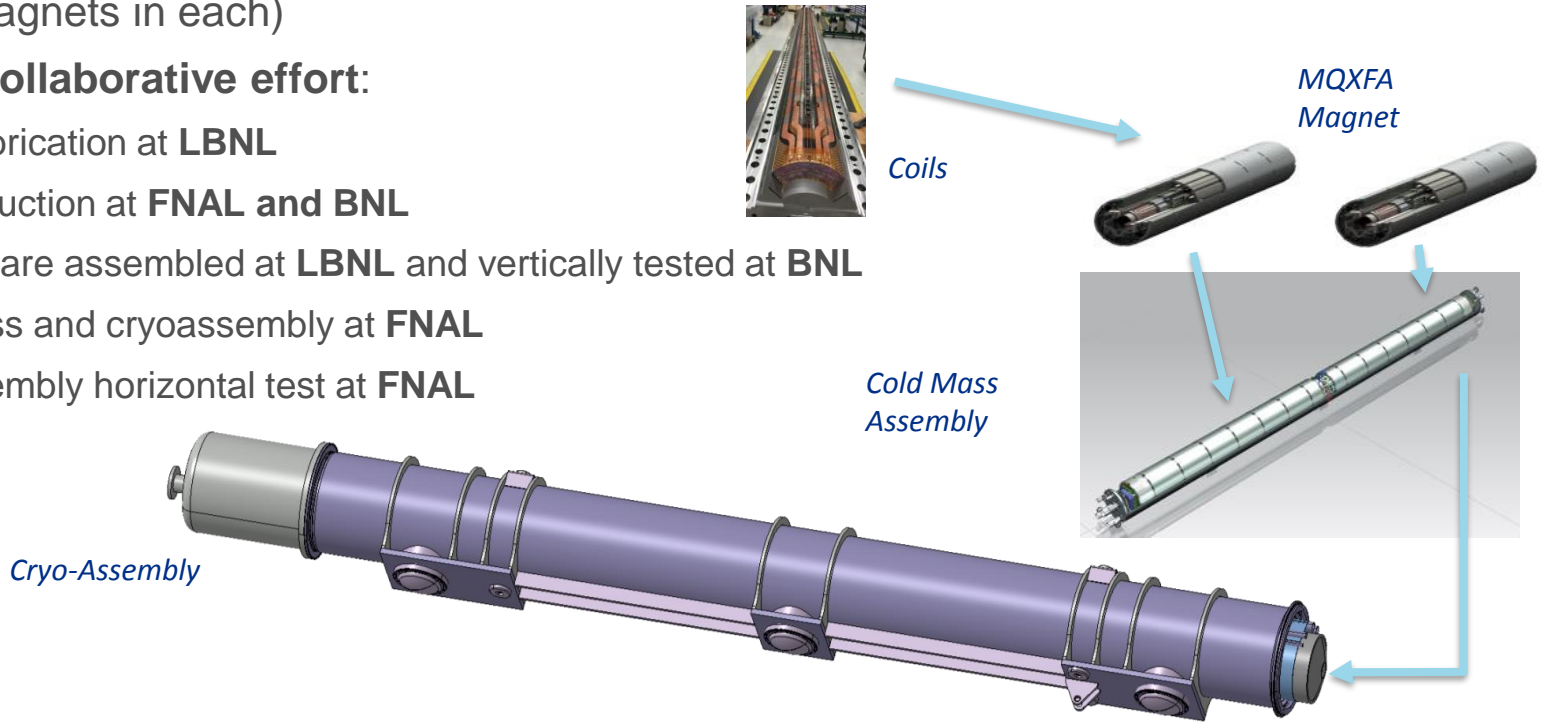

US HL-LHC AUP facilities

- New assembly facility
- Upgraded cryostat horizontal test stand – the only commissioned test location for cryostatted magnets



SC NbTi magnet package for LCLS-II / LCLS-II-HE

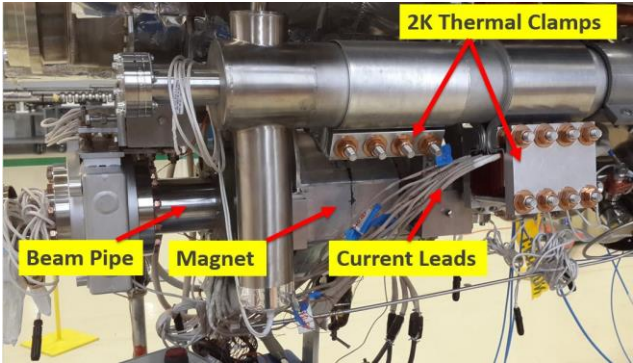
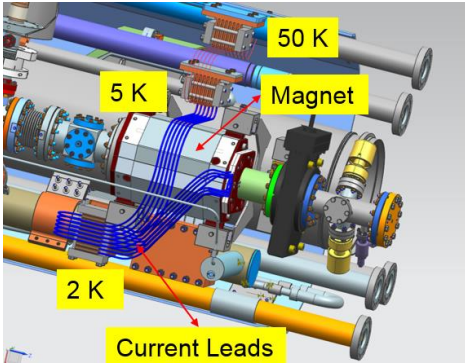

Splittable conduction-cooled quadrupole magnet combined with 2 dipole correctors

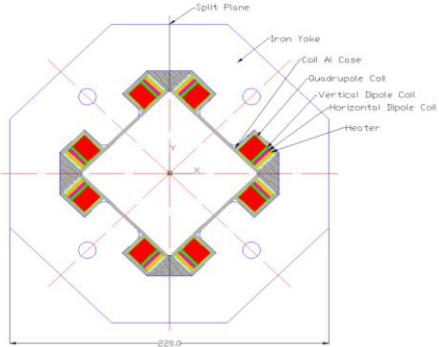

Magnet cross-section

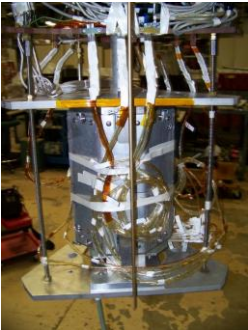

LHe bath test



Conduction cooling test

Mu2e solenoids

- Mu2e detector is embedded in a **series of SC solenoids**
- The magnets are designed to create a low-energy muon beam that can be stopped in a thin aluminum stopping target and provide a constant magnetic field for accurate measurement of momentum of electrons
- **Large NbTi magnets**
 - Production Solenoid (PS): 12 ft long, 4.5 T
 - Transport Solenoid (TS): (2 magnets): 40 ft long, 2 T
 - Detector Solenoid (DS): 30 ft long, 1 T

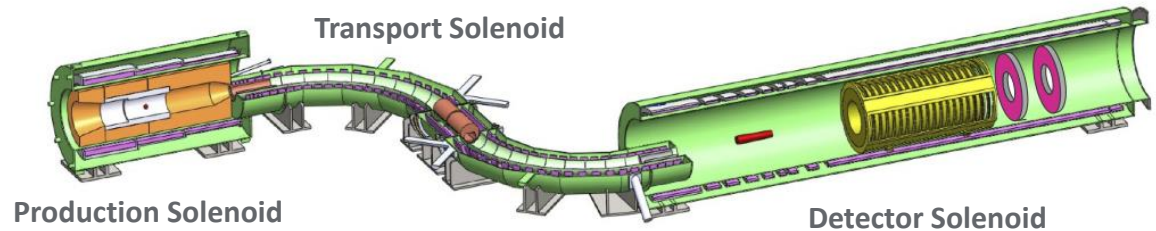

Mu2e TS testing and assembly area

Dedicated area for Transport Solenoids

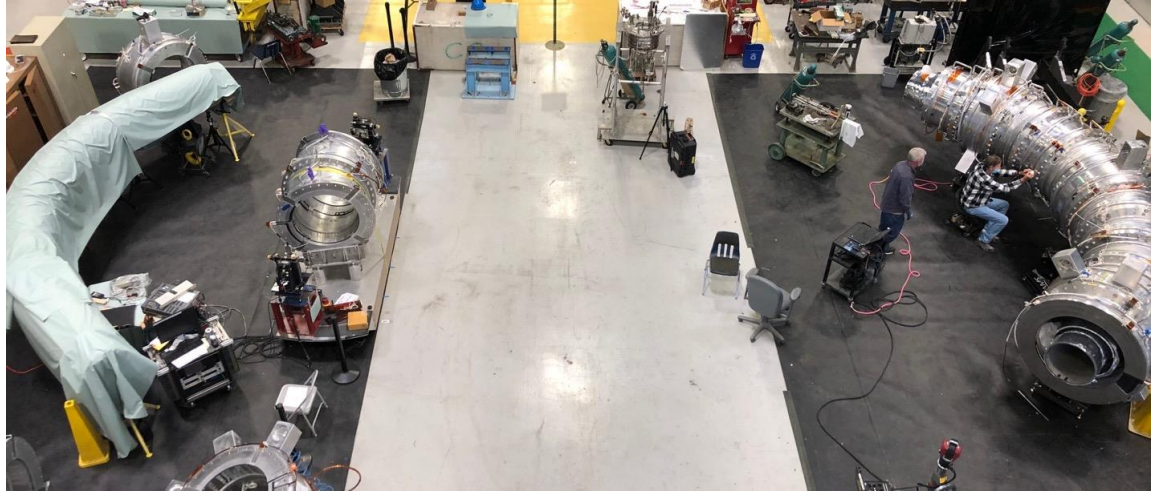
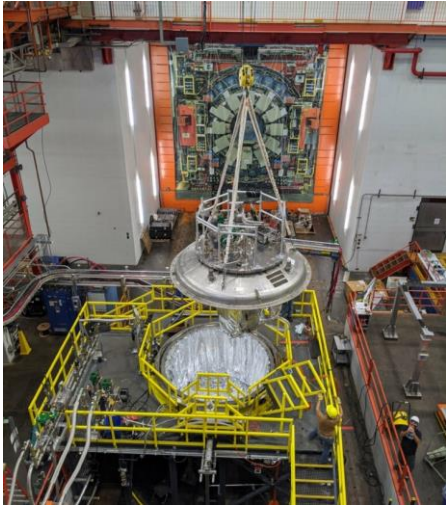

- Cryogenic vacuum vessel for testing conduction-cooled superconducting magnets
- Tevatron satellite LHe refrigerator providing 600 W @ 4.5 K
- 2,500 A power supply
- Quench detection and energy extraction system
- Nano-ohm splice resistance measurement system

- 50 T crane coverage
- Air bearing system for handling
- Magnetic measurement system: vibrating stretched wire
- Building metrology network
- Ultrasonic welding machine
- Bespoke lifting fixture and tooling

CLAS12 toroidal coils

- The **toroidal magnet coils (8)** for CLAS12 experiment were **fabricated at Fermilab** and delivered to **JLAB**
- Reached the operating current of 3,770 A – never quenched



Torus coil

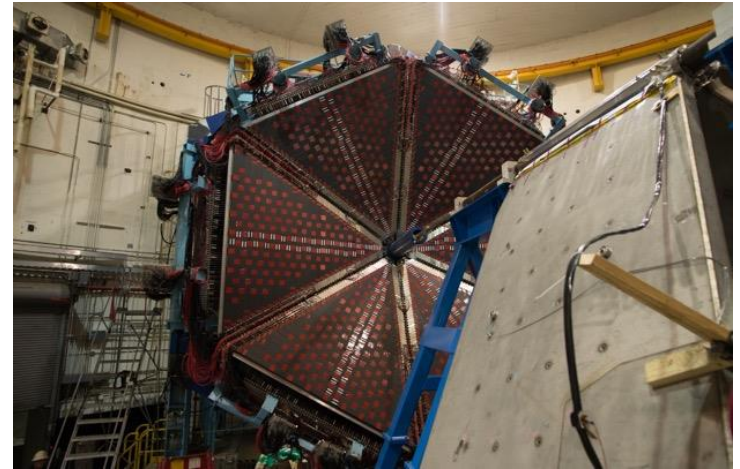

JLAB CLAS12 torus

Nigel, George, Dave,

Today the CLAS12 TORUS magnet at Jefferson Lab, the coils of which you fabricated for us, reached its full operating current of 3770 amps. This last step was uneventful, but as you are surely aware, all the steps along the way to fabricating a "one-of-a-kind" superconducting magnets is a challenge. We had to work to pump all the water out of the magnet, then paused several times during the cooldown to be sure the competing forces were under control, and then, finally during power up, we proceeded cautiously with a significant pause at 2000 amps to make presentations for an OPA review and then at 3000 amps before the final push, which was completed at 2pm today.

We very much appreciate the efforts of George and his team from Tech Division.

I enclose a recent picture of the magnet installed in Hall B.

Thanks a lot for all your efforts on our behalf.

With Best Regards,
Mont

US MDP R&D: 15 T dipole demonstrator

- 1 m long, 60 mm bore diameter Nb_3Sn dipole magnet



Magnet assembly

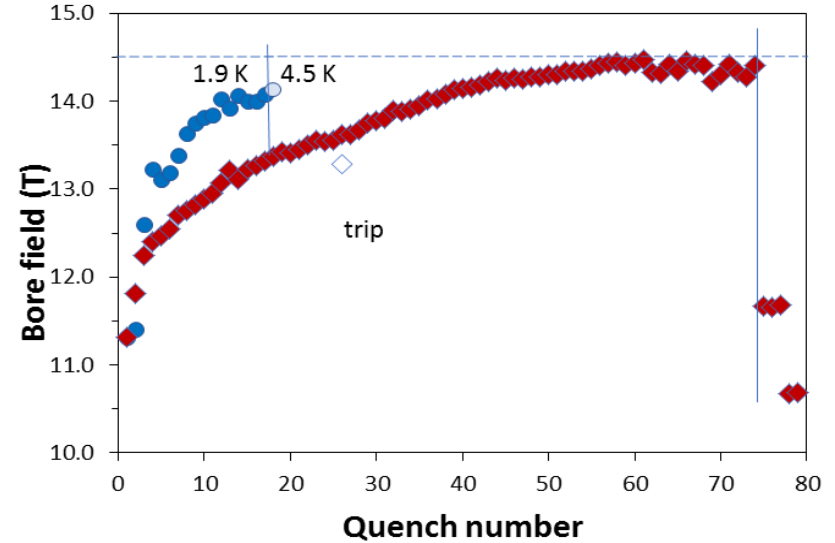

- The magnet achieved **record fields for accelerator type dipole**: 14.5 T at 1.9 K and 14.1 T at 4.5 K
- Paving way toward 16-17 T magnet

Novel SC HTS magnets for linacs

- The main goal of this R&D is to design, fabricate, and test the novel configuration of **HTS multipole magnets with circular coils**
- Advantages:
 - Round coils make possible to use HTS react and wind technology, **one coil could generate multipole field**
 - Magnet could operate at elevated **temperatures up to 77 K**

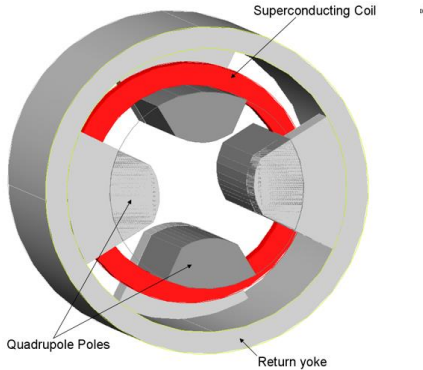

Single coil quadrupole

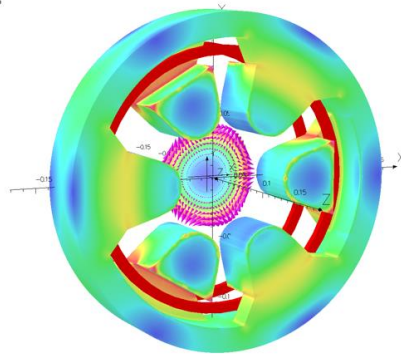

Double Coil Sextupole

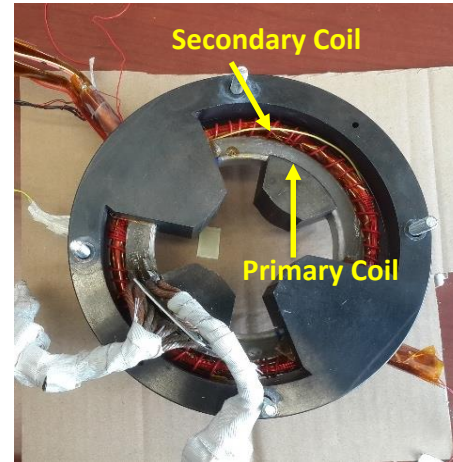

HTS quadrupole test setup

High Field Vertical Magnet Test Facility (HFVMTF)

- New HFVMTF is under construction at Fermilab
- Cable testing:
 - Dipole background magnetic field – 15 T at 1.9 K
 - Samples will be placed in an anti-cryostat providing variable temperature between 4.5 K and 55 K
- Testing high field superconducting magnets, including hybrid magnets, produced by the U.S. MDP
- Jointly funded by DOE offices of HEP and FES.

High Field Vertical Magnet Test Facility

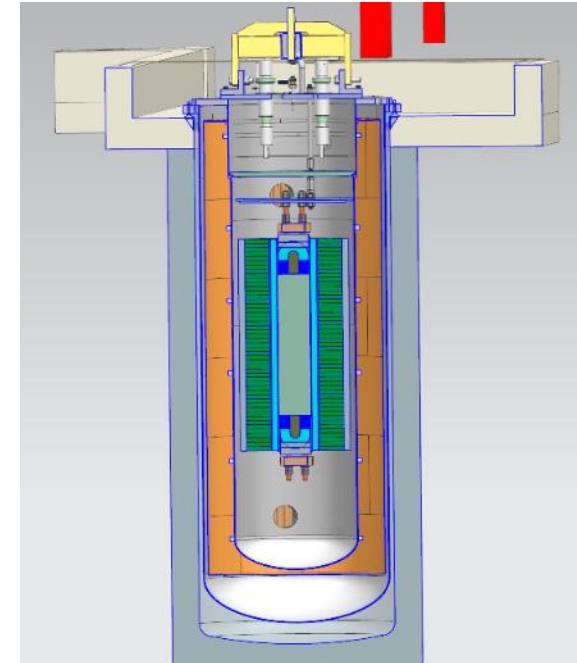

Room temperature magnets

- **Design and manufacture of room temperature magnets** for Fermilab accelerator complex and other DOE Labs (recent examples: **ANL, ORNL**). A large variety, from permanent magnets to injection/extraction kicker magnets with fall/rise time of 50-100 ns, to dipoles running CW at 5 MHz for the Mu2e extinction system.
- We develop **specialized magnets**, such as
 - Gradient magnets
 - Pulsed septum magnets
 - Injection and extraction Lambertsons
 - Complex corrector packages
- **Magnetic measurement** analysis and development of **hardware and software tools and systems** for magnetic measurements

Magnets for Argonne APS-U

Longitudinal gradient magnet prototype



Injection Lambertson

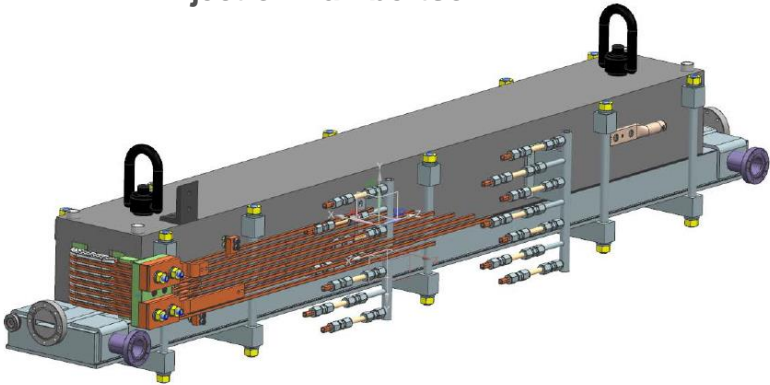

Examples of Fermilab magnets

Pulsed septum magnet for muon delivery ring

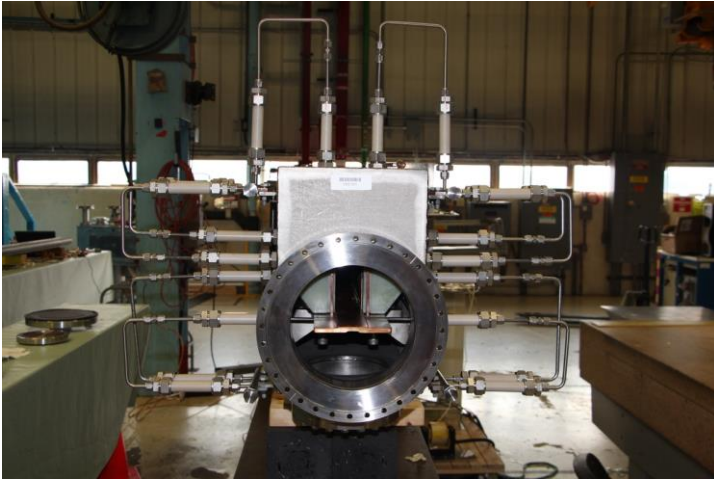

Booster ring corrector package

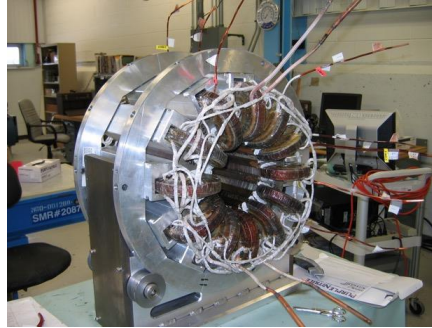

Six magnets in one package

- Normal and skew dipole (3.24 T-m/s)
- Normal quadrupole (88 T-m/m/s)
- Skew quadrupole (0.8 T-m/m/s)
- Normal and skew sextupole (2350 T-m/m²/s)

Magnetic measurements & Quench protection

- **Probe development** – printed circuit boards are routinely used for rotating coil probes, featuring
 - micron level placement of wires; multi-layer designs with high sensitivity
 - geometries which allow high levels of suppression of effects from main fields (“bucking”)
 - cost effective way of building probes
 - Designed and built probes for **ANL and LBNL**, have a contract with **BNL**
- Newly-built **rotating coil** and **Single Stretched Wire Systems (SSW)** for alignment and harmonics measurements. A SSW system was built for **KEK**
- New **Quench Protection and Monitoring system** was designed and assembled for the cryo-assembly horizontal test
 - Three-tier design: Tier 1 – primary QD, Tier 2 – secondary QD, and Tier 3 – System Monitoring and Data Management



Next Generation of Digital Quench Protection and Monitoring System.
Chassis with 32 Isolated Analog Channels and Digital Controller.

Summary for Magnets

Potential Fermilab contributions to **EIC** in the area of Magnets:

- SC NbTi or Nb₃Sn magnets: design, fabrication and testing (vertical and horizontal)
- Small conduction-cooled HTS magnets
- Specialized normal conducting magnets
- Probes for magnetic measurements
- Quench protection systems

Cryogenics

Cryogenic distribution systems development at Fermilab

- Fermilab has extensive experience in **developing CDS for projects**
- Scope of work includes
 - Developing **reference model designs**
 - Used as input for project tunnel space allocation
 - Used as input for final design and build to specification procurements
 - Developing **procurement specification** and managing **procurements**
 - **Fabrication** of multi-channel cryolines
 - **Installation**
- Recent project experience
 - **Mu2e Experiment** at Fermilab (2012 – 2021)
 - **LCLS-II** at SLAC (2013 – 2018)
 - **LCLS-II High Energy** at SLAC (2020 – 2024)
 - **PIP-II** at Fermilab (2018 – 2025)

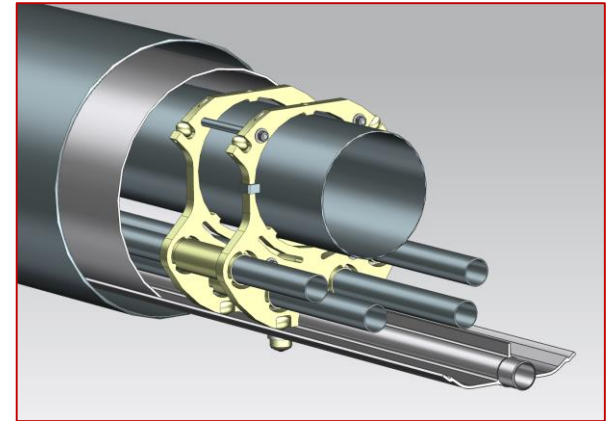

Mu2e cryogenic distribution

■ Features

- **Four superconducting solenoids** refrigerated by two repurposed Tevatron Satellite Refrigerators (1,200 W @ 4.5 K)
- **One Distribution** and **four Feed** cryogenic **valve boxes** allow for independent solenoid cooldown and warmup
- **Unique cryogenic superconducting transfer lines** route both cryogen and power to the solenoids
- Solenoid commissioning in 2022

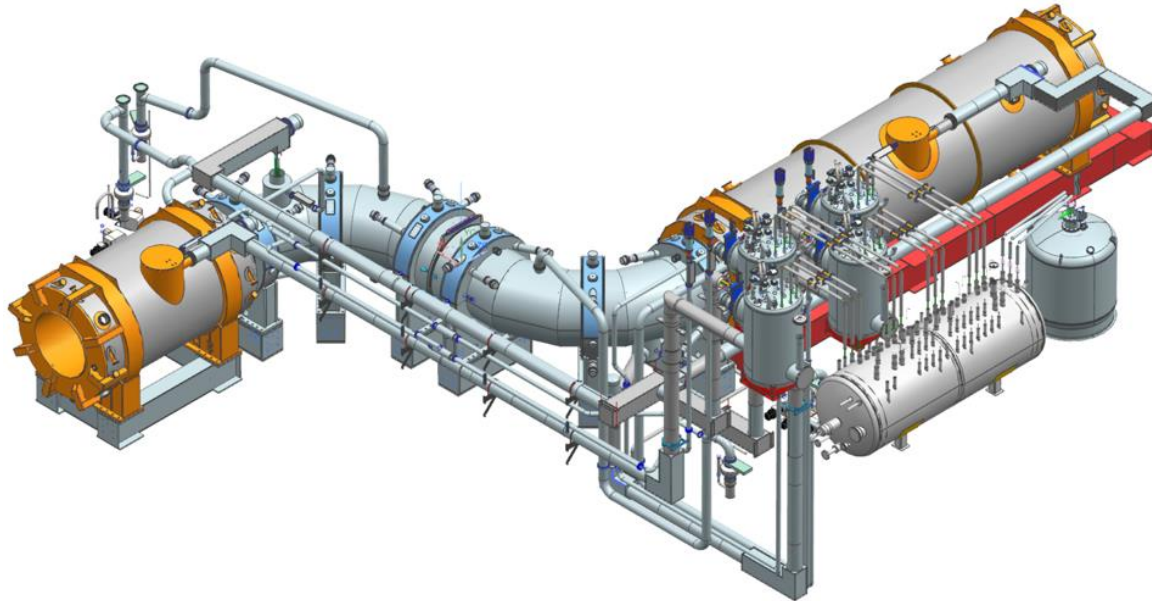

LCLS-II tunnel cryogenic distribution system

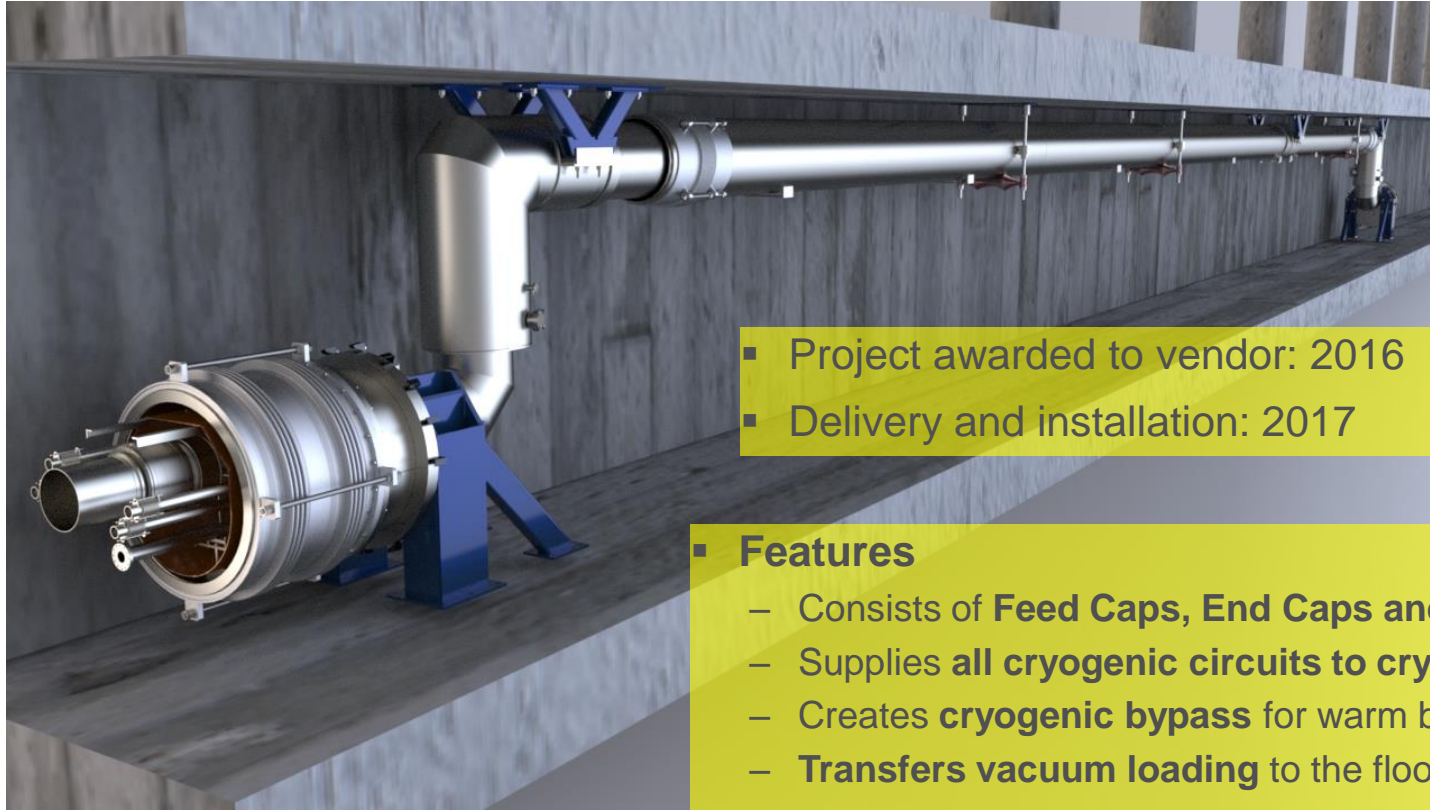

- Project awarded to vendor: 2016
- Delivery and installation: 2017

▪ Features

- Consists of **Feed Caps, End Caps and Transfer Lines**
- Supplies **all cryogenic circuits to cryomodules**
- Creates **cryogenic bypass** for warm beamline components
- **Transfers vacuum loading** to the floor

LCLS-II Distribution Box

- Project awarded to vendor: 2016
- Delivery and installation: 2018



- **Features**

- Connects cryomodules in the linac tunnel with surface portion of cryogenic distribution
- Provides pressure relieving for all process lines for linac cryomodules and cryogenic distribution system
- Contains central 4 K to 2 K heat exchanger for flow to cryomodules

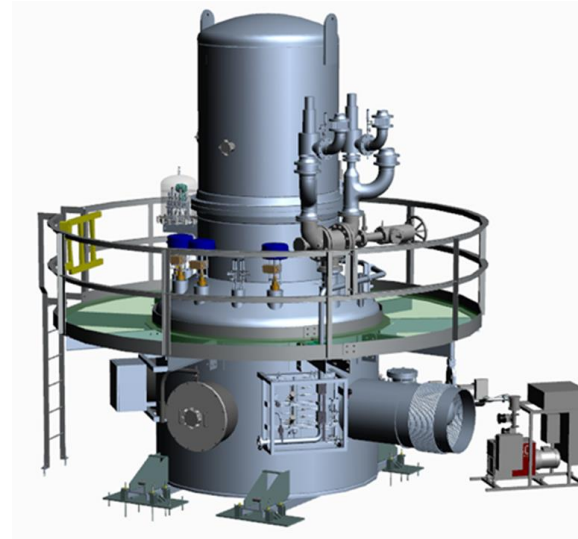

PIP-II cryogenic distribution

■ Features

- Contains **200 m of transfer line** containing six cryogenic pipes
- **Distribution valve box** for flow control and relieving of each cryogenic circuit
- **25 bayonet cans** to connect cryomodules using U-tubes

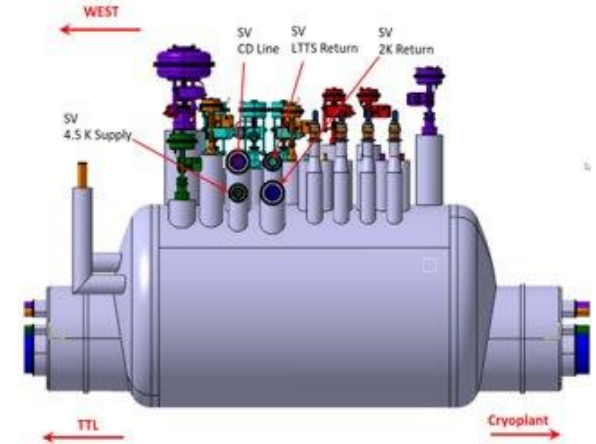
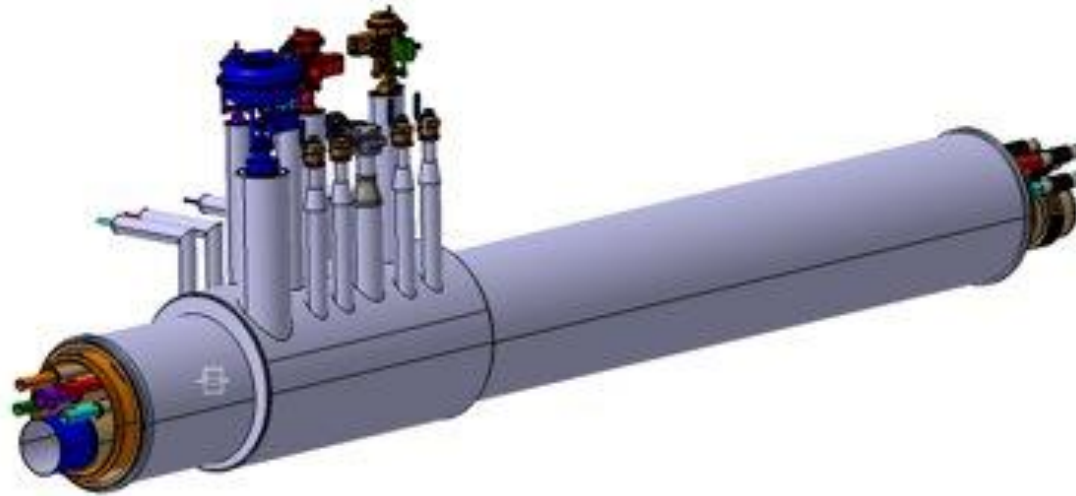

Summary for Cryogenics

- Fermilab has expertise and recent experience in developing cryogenic distribution systems (CDS) for internal and external projects (SRF accelerators and detectors)
- This might be a contribution to **EIC**

Thank you!

