



# Introduction to FLUKA

# A particle interaction and transport Monte Carlo code

- Born in the 60's at **CERN** with Johannes Ranft
- Further developed in the 70s and 80s in a collaboration between **Leipzig University**, **CERN** and **Helsinki University** for applications, e.g., at CERN's high energy accelerators, and in the 90s with **INFN**, among others for the design of SSC and LHC
- From 2003 until August 2019 maintained and developed under a **CERN & INFN** agreement
- From December 2019, new **CERN** distribution aiming to ensure FLUKA's long-term sustainability and capability to meet the evolving requirements of its user community, welcoming contributions by both established FLUKA contributors as well as new partners.
- Presently a joint development & management team including CERN Engineering Department and Radiation Protection Group and ELI-Beamlines (Prague) is in place

<https://fluka.cern>

<https://cern.ch/fluka-forum>



Release of FLUKA 4-0.1  
2020-08-24 [Release](#)

FLUKA online training for beginners (Sept/Oct 2020)  
2020-08-01 [Event](#)

Release of FLUKA 4.0 and Flair 3.1  
2020-06-30 [Release](#)

FLUKA online training in autumn 2020  
2020-06-29 [Event](#)

more

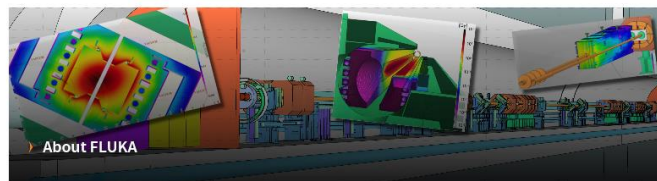

[Installing, Running and Runtime Errors](#)  
Category for questions related to installing and running FLUKA and Flair

[Flair](#)  
Category for questions related to the graphical user interface Flair.

[Source Definition](#)  
Category for questions concerning built-in source options, like particle beams, hadron-hadron collisions or isotropic sources.

[Geometry and Materials](#)  
Category for material and geometry-related questions including topics like transformations and lattices.

[Scoring and Biasing](#)  
Category for questions related to built-in scoring and biasing options.

[Physics, Transport and Magnetic Fields](#)  
Category for physics-related questions, as well as questions of transport and magnetic field options.

[Advanced Features and User Routines](#)  
Category for questions related to advanced features and user routines.

[Applications](#)  
Category for questions related to specific applications.

[User Forum](#)

[Download](#)

[Documentation](#)

[Flair Graphical User Interface](#)

[Courses and events](#)

FLUKA 4-0.1, 2020-08-24

Flair 3.1-2st, 2020-07-10

Registration problems? Enquiry about a commercial license? Enquiry about an institutional license for accessing the source code? Feedback to the website? Use the [contact form](#).

FLUKA User Forum

Discussion forum for users of the FLUKA Monte Carlo code and its graphical user interface Flair distributed by CERN on [fluka.cern](https://fluka.cern) and [cern.ch/flair](https://cern.ch/flair).

all categories Categories Latest Unread (37) + New Topic

Category	Topics	Latest
<b>Announcements</b> As of December 2019, this discussion list represents the official forum for users of the FLUKA Monte Carlo code and its graphical user interface Flair, distributed by the European Organization for Nuclear Research (CERN).	7	
<b>Installing, Running and Runtime Errors</b> Category for questions related to installing and running FLUKA and Flair.	26	2 unread
<b>Flair</b> Category for questions related to the graphical user interface Flair.	27	1 unread
<b>Source Definition</b> Category for questions concerning built-in source options, like particle beams, hadron-hadron collisions or isotropic sources.	2	3 unread
<b>Geometry and Materials</b> Category for material and geometry-related questions including topics like transformations and lattices.	8	7 unread
<b>Scoring and Biasing</b> Category for questions related to built-in scoring and biasing options.	10	3 unread
<b>Physics, Transport and Magnetic Fields</b> Category for physics-related questions, as well as questions on	12	11 unread

Recent posts:

- No Random file available - 1  
Installing, Running and Runtime Errors - 10h
- Software requirements of FLUKA and Flair - 3  
Installing, Running and Runtime Errors - 1d
- Bugs in FLAIR 3.0-8a - 6  
Staff - 1d
- Nothing provides python3-imaging-tk issue while installing geoviewer on centos 8 - 6  
Flair - 1d
- Number of processed DETECT cards - 2  
Scoring and Biasing - 3d
- Gnuplot errors or warnings found - 5  
Flair - 5d
- Make: /usr/local/fluka/ffl/ffl: Command not found - 4  
Advanced Features and User Routines - 5d
- Installation of FLAIR and the geoviewer on Mac OS Catalina with Home-brew - 2  
Mac OS Catalina with Home-brew - 6d

(an independent one time registration is requested to post)

# New licensing scheme

## Registration options

FLUKA *Single User License Agreement*

Affiliates of institutes with a FLUKA *Institutional License Agreement*

CERN Staff members and Fellows

Affiliates of institutes which signed the FLUKA *Memorandum of Understanding*

Companies which purchased a FLUKA *Commercial License Agreement*

*including access to the source code*

*including access to the development version*

- Licenses are free except for commercial use
- They are granted for non-military purposes only

# Microscopic process modeling for macroscopic quantity assessment

A (hadronic) shower implies a lot of different physics processes, touching a very broad energy [time-space] scale

Its description relies on the organic integration of diverse **theories and models**, and requires as essential pieces of **information**:

- reaction cross sections
- exclusive fragment production
- nuclide structure and decay data
- evaluated quantities of neutron induced reactions

Monte Carlo simulation is an effective way to calculate **macroscopic quantities** (such as **energy deposition**, dpa, particle fluence, activation and residual dose rate) with an accuracy reflecting the quality of the critical processes implementation

Multipurpose widespread codes are available: FLUKA, GEANT4, MARS, MCNP, PHITS, ...

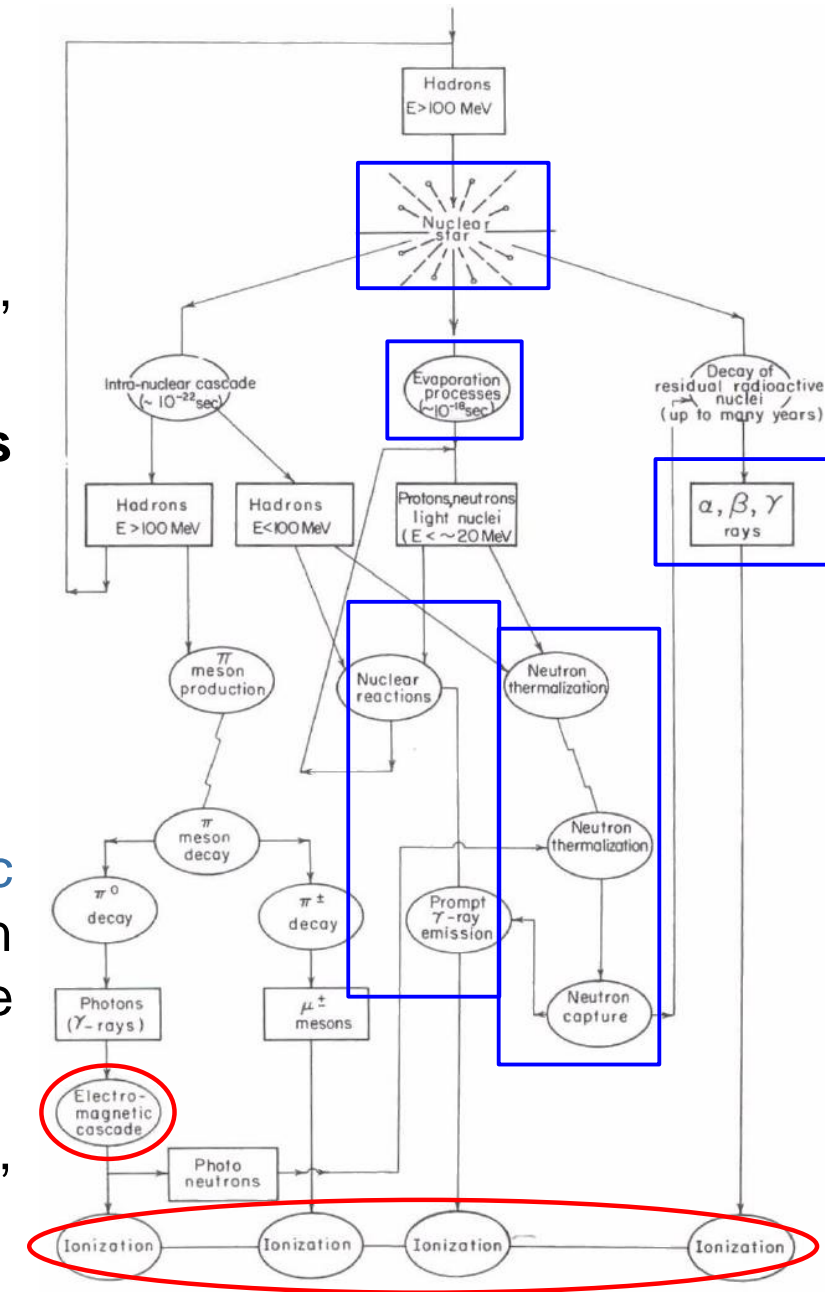

# Radiation consequences

Heating

Thermal shock

Quenching

Deterioration

Oxidation, radiolysis, ozone production

Gas production

Single event effects in electronic devices

Shielding requirements

Access limitations, radioactive waste, air activation

Beam Loss Monitors (BLM)

Radiation Monitors (RadMon)

Tumor cell destruction

## relevant macroscopic quantity

energy deposition (integral power)

energy deposition (power density)

energy deposition (power density)

energy deposition (dose), particle fluence, DPA

energy deposition

residual nuclei production

high energy hadron fluence

[+ neutron fluence, energy deposition (dose)]

particle fluence (*prompt* dose equivalent)

*residual* dose rate and activity

energy deposition

thermal neutron and high energy hadron fluence

energy deposition (dose, biological dose)

# FLUKA capabilities

- hadron-hadron and hadron-nucleus interactions
- nucleus-nucleus interactions
- photon interactions (>100 eV)
- electron interactions (> 1 keV; including electronuclear)
- muon interactions (including photonuclear)
- neutrino interactions
- particle decay
- low energy (<20 MeV) neutron library
- ionization and multiple (single) scattering (including all ions down to 250 eV/u)
- combinatorial geometry and lattice capabilities
- voxel geometry and DICOM importing
- magnetic field, and electric field in vacuum
- analogue or biased treatment
- on-line buildup and evolution of induced radioactivity and dose

built-in scoring of several quantities (including DPA and dose equivalent)

- |   |                    |                                    |
|---|--------------------|------------------------------------|
| ✓ Accelerator design  | ✓ Shielding design | ✓ Radiation protection             |
| ✓ Dosimetry   | ✓ Radiation damage | ✓ Radiation to electronics effects |
| ✓ Particle physics (calorimetry, tracking and detector simulation, ...) |                    |                                    |
| ✓ Cosmic ray physics  | ✓ Neutrino physics | ✓ ADS systems, waste transmutation |
| ✓ Medical applications, hadrontherapy                                   |                    | ✓ Neutronics                       |



# Some examples



# Accelerator geometries

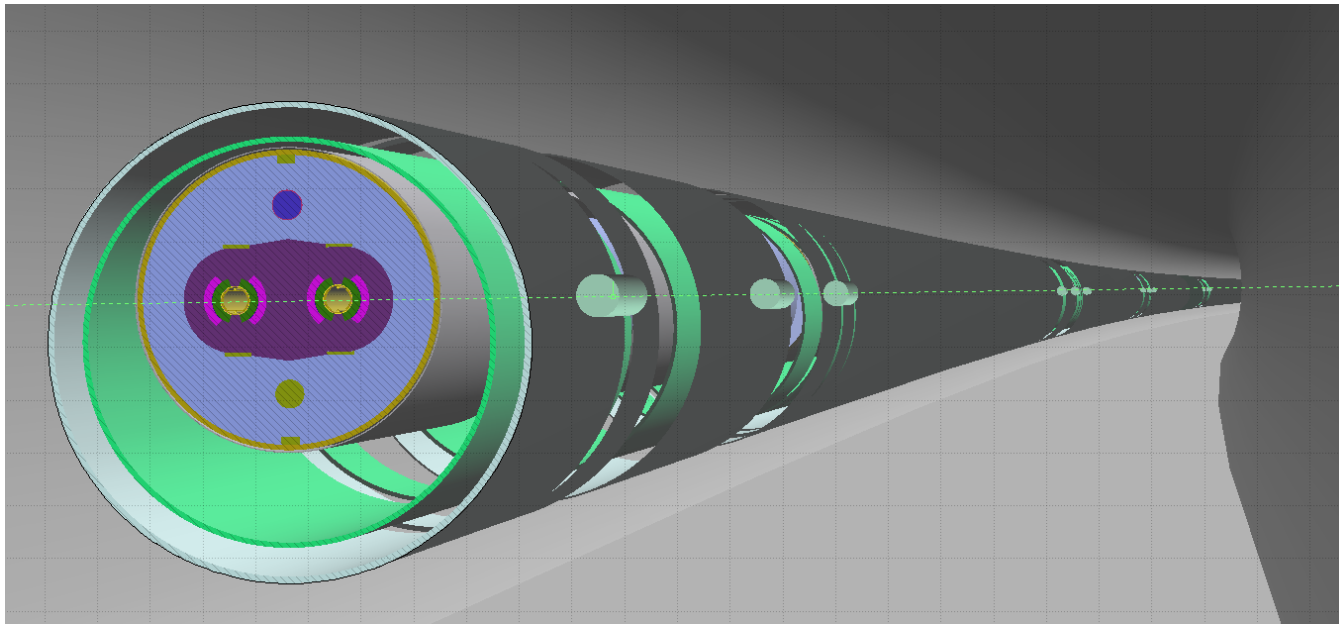
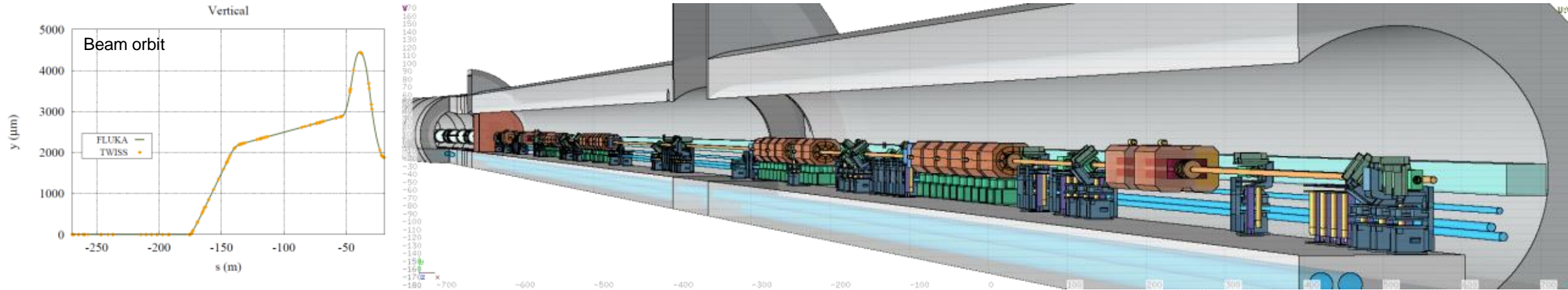

From DETAILED MODELS OF ACCELERATOR COMPONENTS WITH ASSOCIATED SCORING and the ELEMENT SEQUENCE AND RESPECTIVE MAGNETIC STRENGTHS, as given IN THE MACHINE OPTICS (TWISS) FILES, the **AUTOMATIC CONSTRUCTION OF COMPLEX BEAM LINES**, including collimator settings and element displacement (BLMs), is achievable, profiting from roto-translation directives and replication (lattice) capabilities.

## LINE BUILDER

[A. Mereghetti et al.,  
IPAC2012, WEPPD071, 2687]



# Beam loss description at the LHC

[A. Lechner et al.,  
Phys. Rev. AB 22 (2019) 071003]

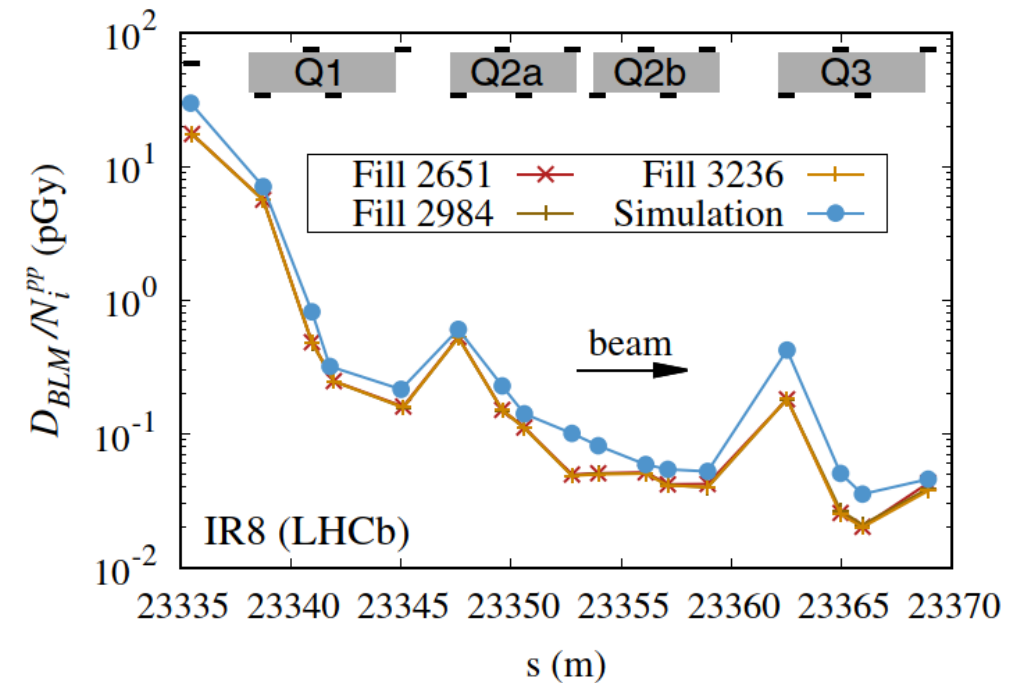
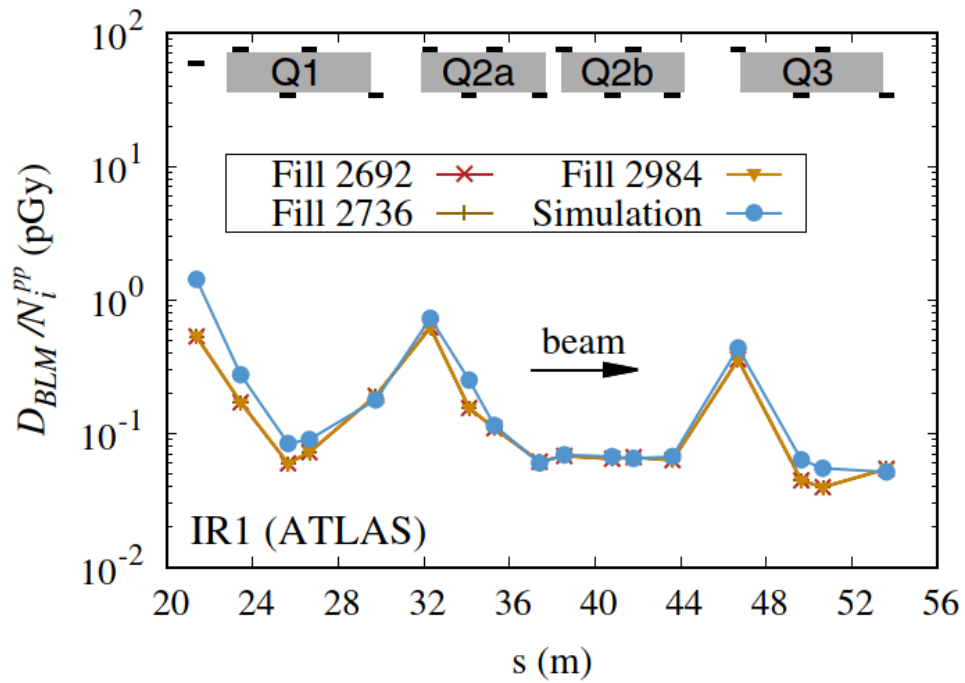
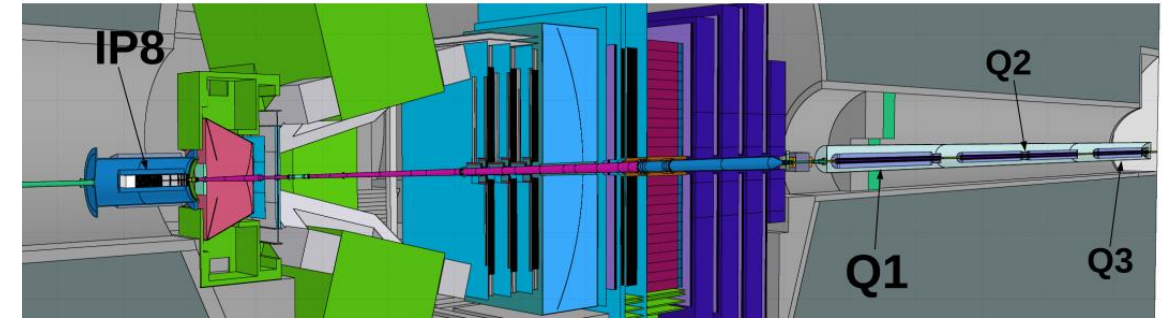
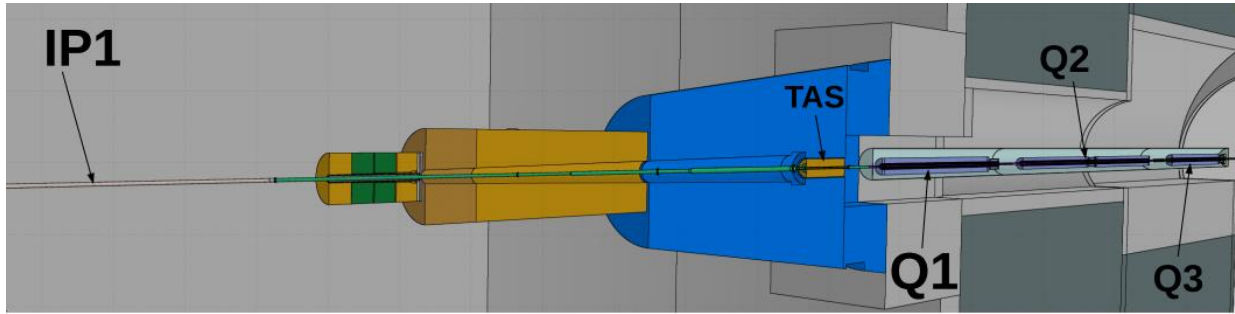

# Activation benchmarking

@ CERN SHIELDING BENCHMARK FACILITY (24 GeV/c p)

[E. Iliopoulou and R. Froeschl]

Situated laterally above the CHARM target

for deep shielding penetration studies (Detector calibration, Detector inter-comparison, Activation)

360cm of concrete and barite concrete  
plus 80cm of cast iron

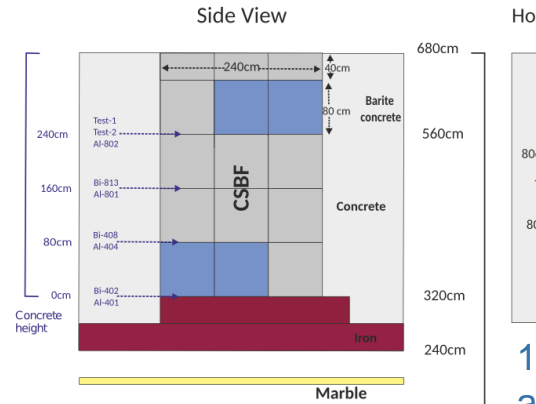

Horizontal cut at 560cm height

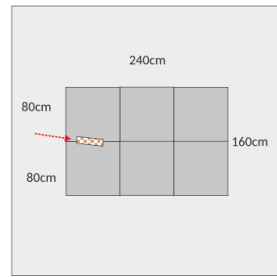

11 Bismuth and Aluminum samples  
at different heights in CSBF and also  
inside CHARM (@ -80cm)

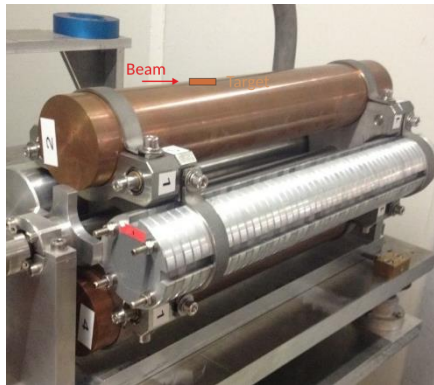

@ CHARM (CERN High energy AcceleRator Mixed field facility,

to study radiation effects on electronic components)

$5 \times 10^{11}$  protons/pulse, 350ms pulse length, max. average beam intensity  $6.6 \times 10^{10}$  p/s

three 50cm long 8cm diameter targets: Copper, Aluminum, Aluminum with holes

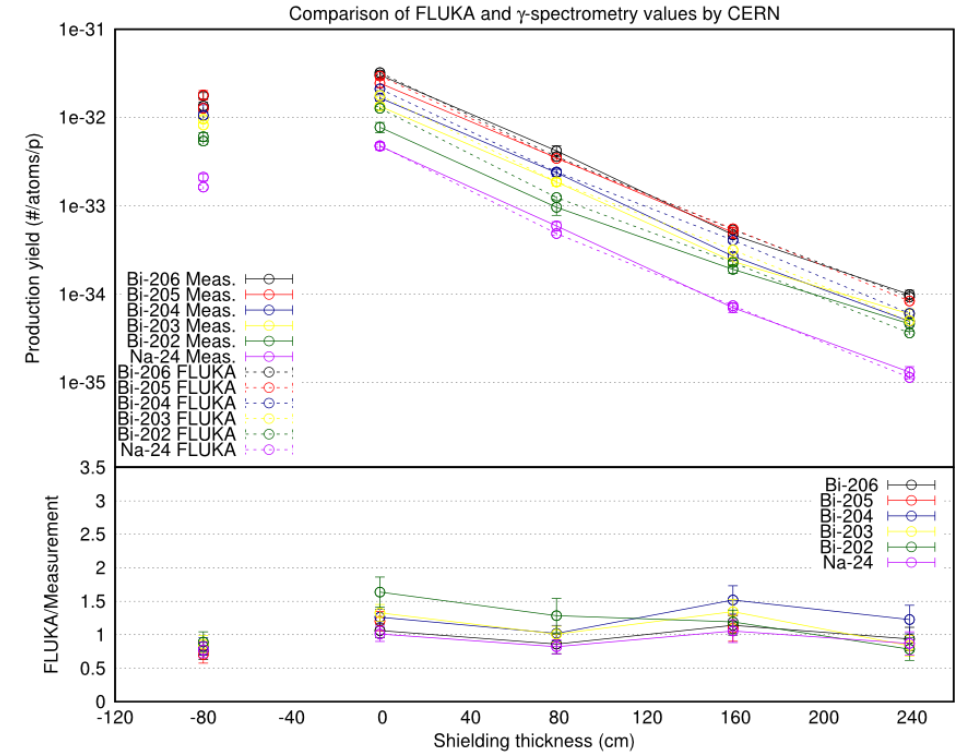

# Medical physics: radiotherapy

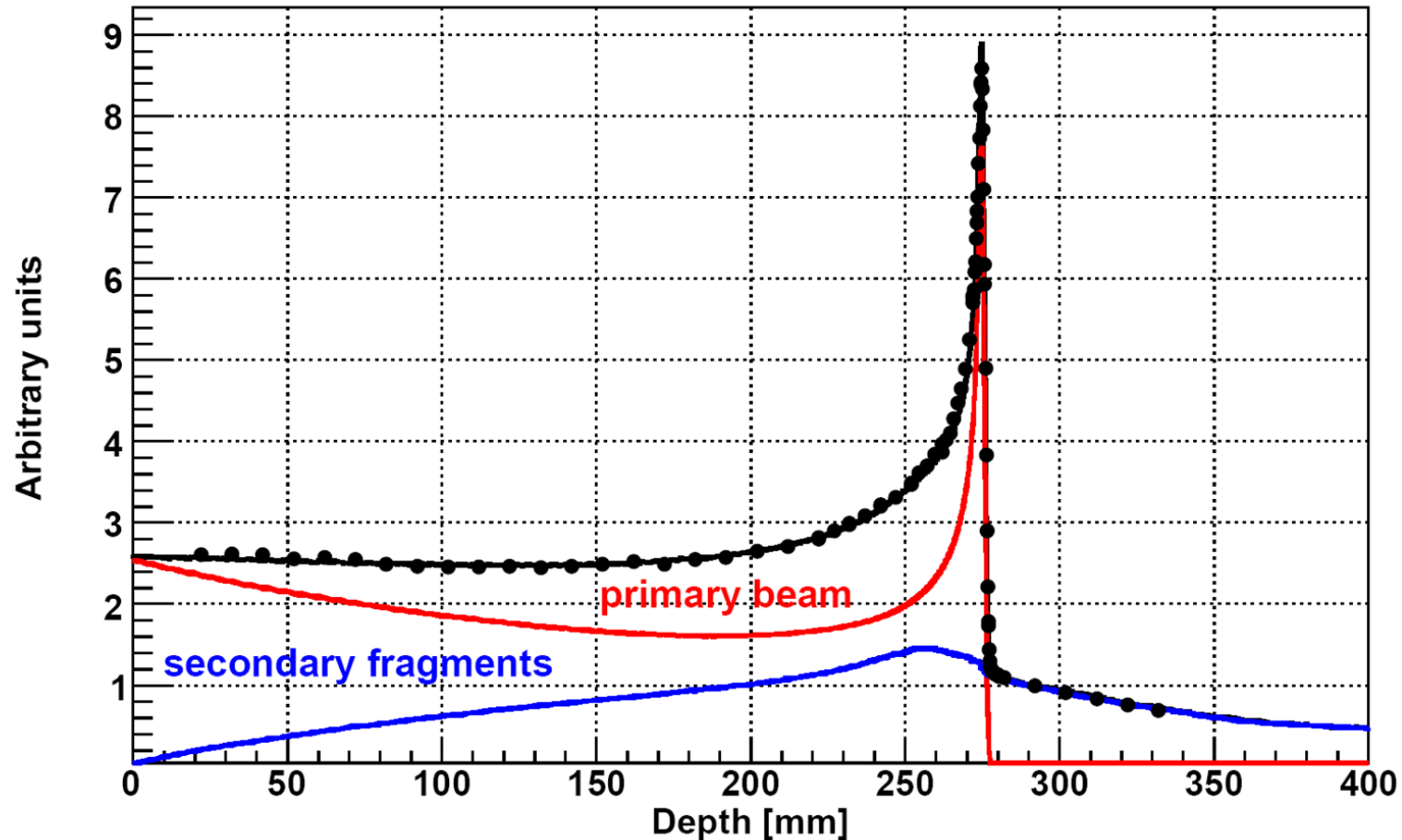

Bragg peak in a water phantom  
400 MeV/A C beam:  
The importance of fragmentation

[Exp. Data (points) from Haettner et al, Rad. Prot. Dos. 2006  
Simulation: A. Mairani PhD Thesis, 2007, Nuovo Cimento C, 31, 2008]

# Dosimetry and cosmic rays

- Complete simulation of cosmic rays interactions in the atmosphere, by means of a dedicated CR package available to users
- Model of airplane geometry
- Response of dosimeters

Ambient dose equivalent from neutrons at solar maximum on commercial flights from Seattle to Hamburg and from Frankfurt to Johannesburg

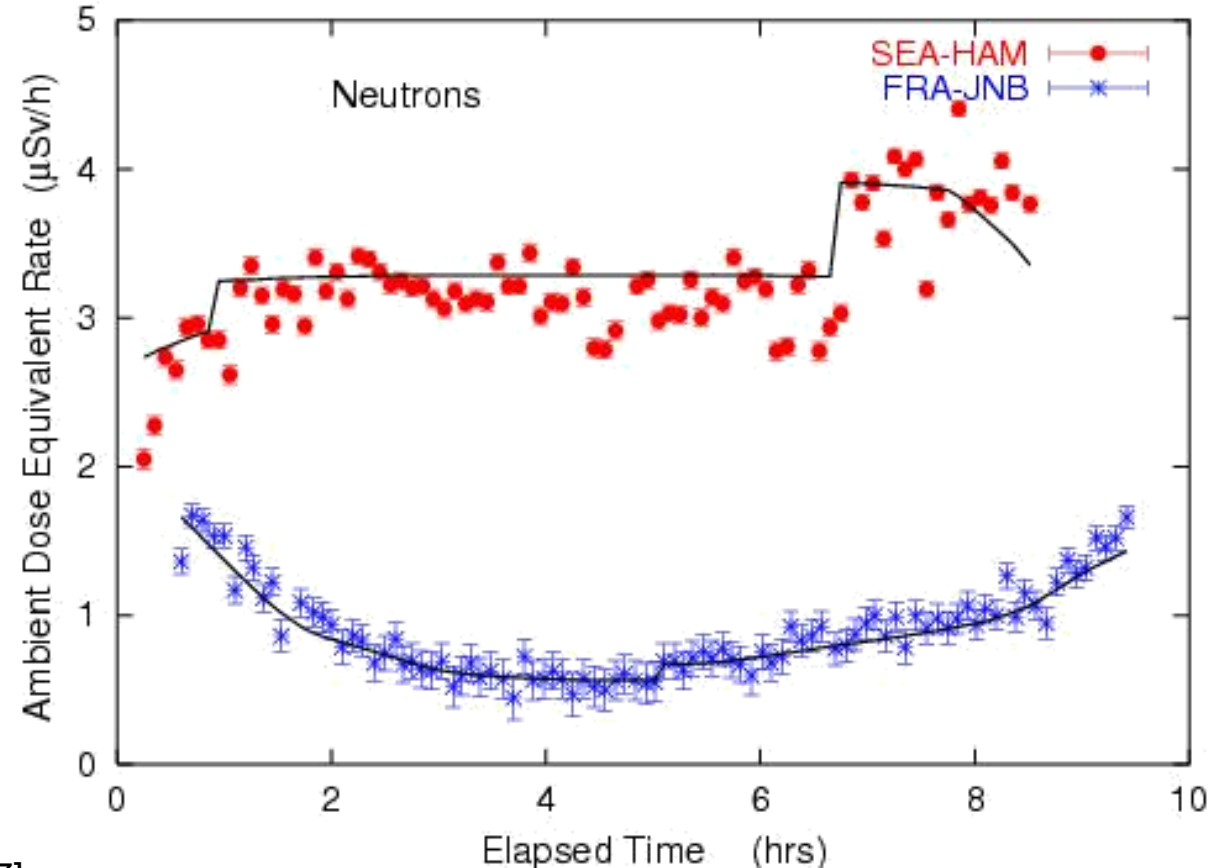

[Solid lines: FLUKA simulation  
S. Roesler et al.,  
Rad. Prot. Dosim. 98 (2002) 367]

# Program of this course

9 AM– 1 PM CEST every day:

featuring lectures, demos, on-line exercises, and multiple-choice questionnaires

Day 1	Welcome	Introduction to FLUKA	Monte Carlo basics	BREAK	Basic input & Flair introduction	Hands-on	
Day 2	Geometry - Basic	Exercise		BREAK	Materials	Exercise	
Day 3	Geometry editor	Exercise		BREAK	Simple sources/ Preprocessor	Exercise	
Day 4	Scoring: intro & USRBIN	Exercise		BREAK	EM & thresholds + AUXSCORE	Exercise	
Day 5	Scoring: USRTRACK, USRBDX, USRYIELD & R2E	Exercise		BREAK	Magnetic & electric fields	Exercise	
Day 6	Geometry - Advanced	Exercise		BREAK	Flair - Advanced	Hands-on	
Day 7	Biasing	Exercise		BREAK	Activation	Exercise	
Day 8	Source routine	Hands-on		BREAK	Standard output	Common errors/mistakes	
Day 9	Advanced sources	Medical applications		BREAK	Hands-on	Physics	
Day 10	Secondary beam exercise			BREAK	Advanced topics	Course evaluation	Conclusion



