

CRP and mechanical structure design for Vertical Drift

B.Aimard, G.Deleglise, D.Duchesneau, N.Geffroy, H.Meringolo

- Overview and general characteristics
 - Layout and dimensions
 - Thermal contraction aspects
- Preliminary mechanical calculations
 - Anode attachment points
 - Supporting PCB frame
 - Super CRP structures
- Summary

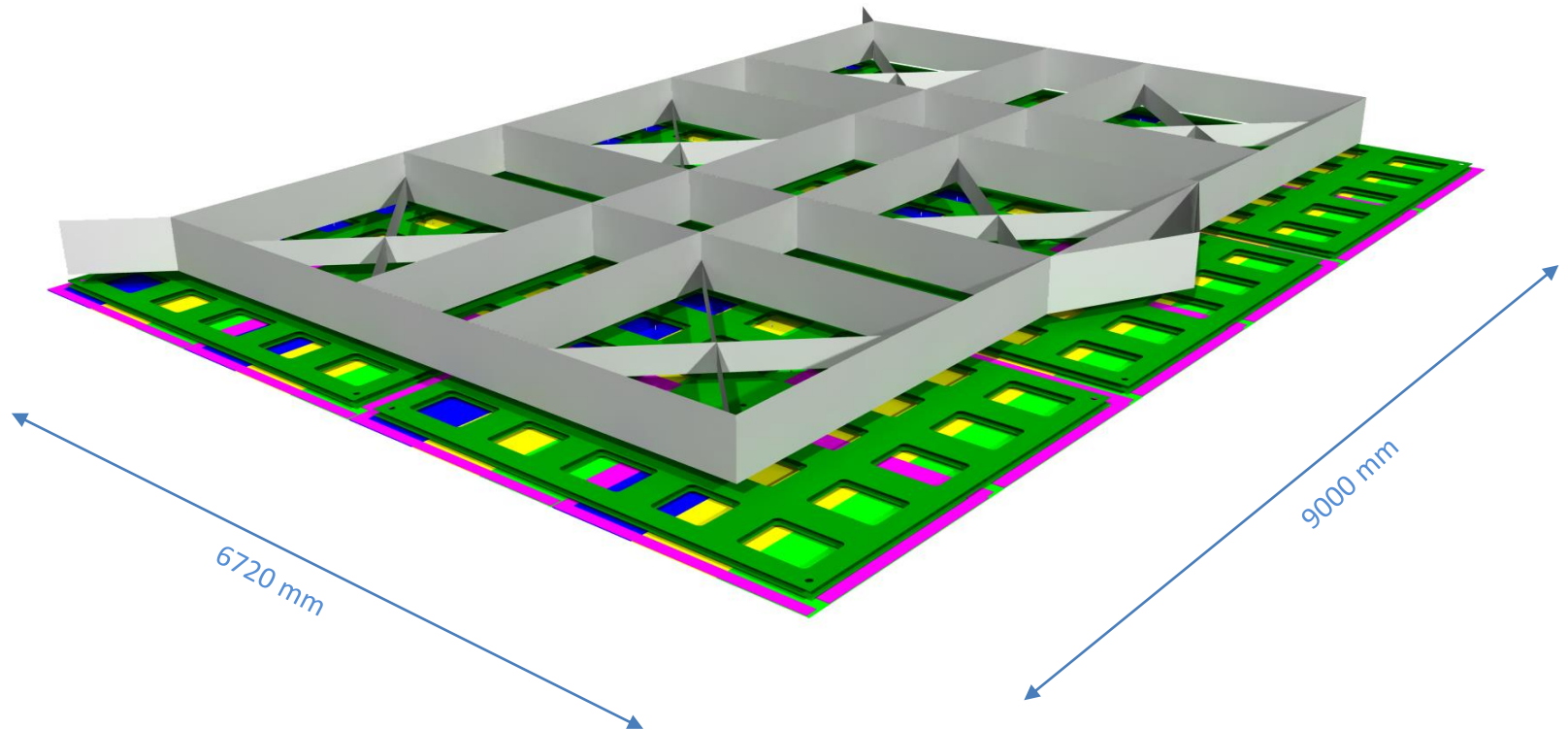

Super-structure

- Invar
- About 1600 kg (before diet)
- 3 anchoring points

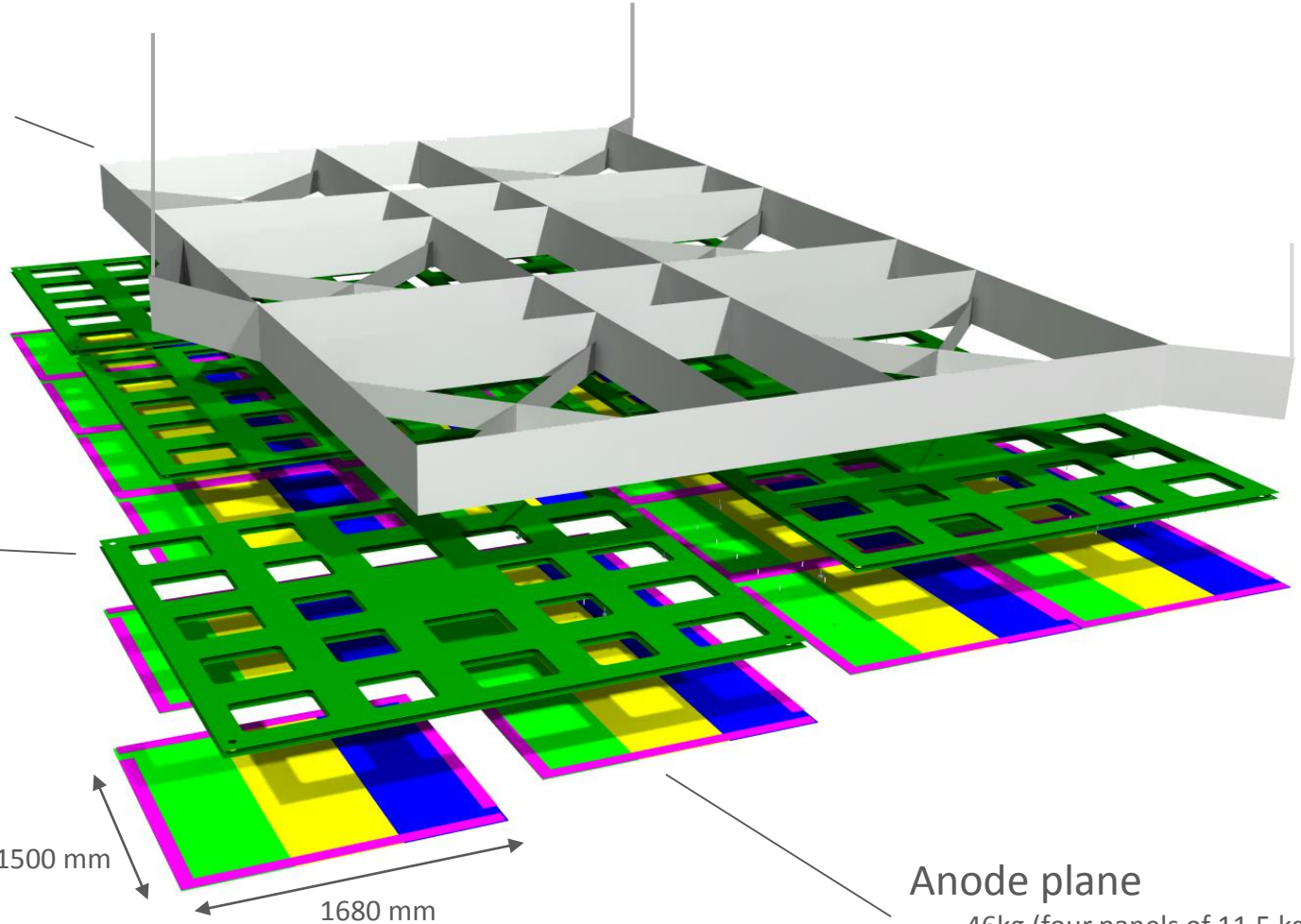

Structural PCB Sandwich

- less than 200 kg (to be refined)

Anode plane

- 46kg (four panels of 11,5 kg)
- 3000 x 3375 mm

Total Super-CRP mass : 2800 kg
 Cathode mass estimation : 600 kg
Mass/suspension cable : 1200kg

Anode planarity specification : +/-2,5mm @ cold

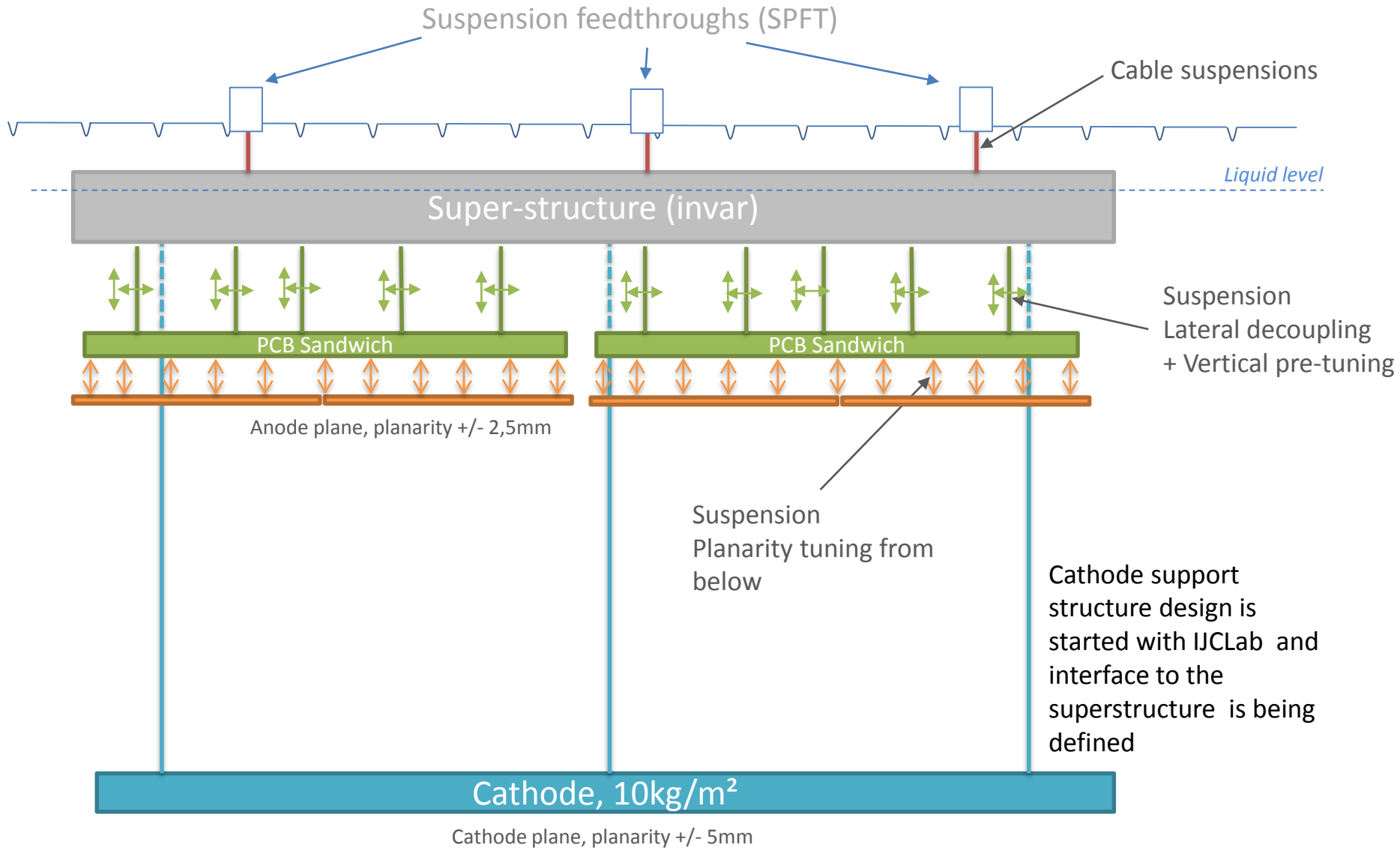

- Easy connection
- Lateral sliding
- Vertical adjustment
- > 5 pieces / CRP

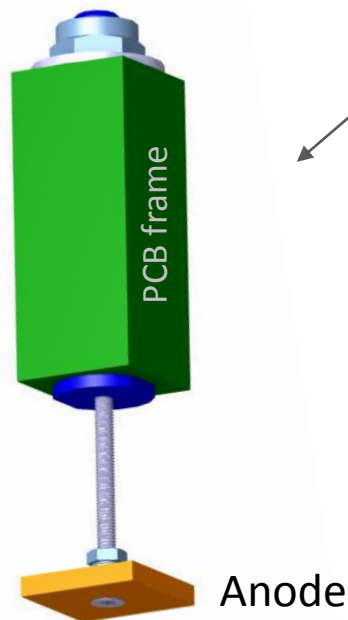
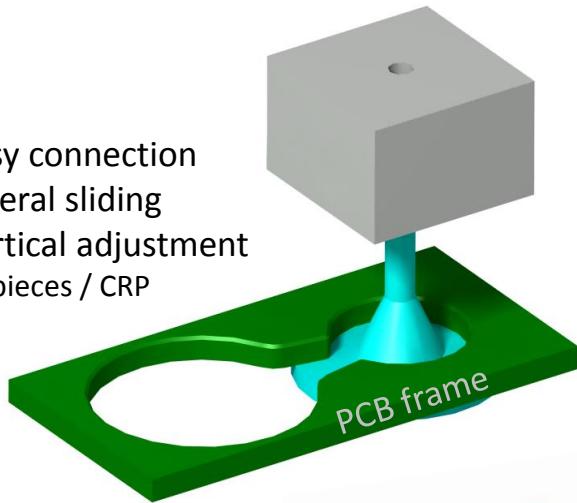

- Vertical adjustment
- Compacity
- Electrical insulation (non-metallic screw)
- > 36 pieces / Anode plane

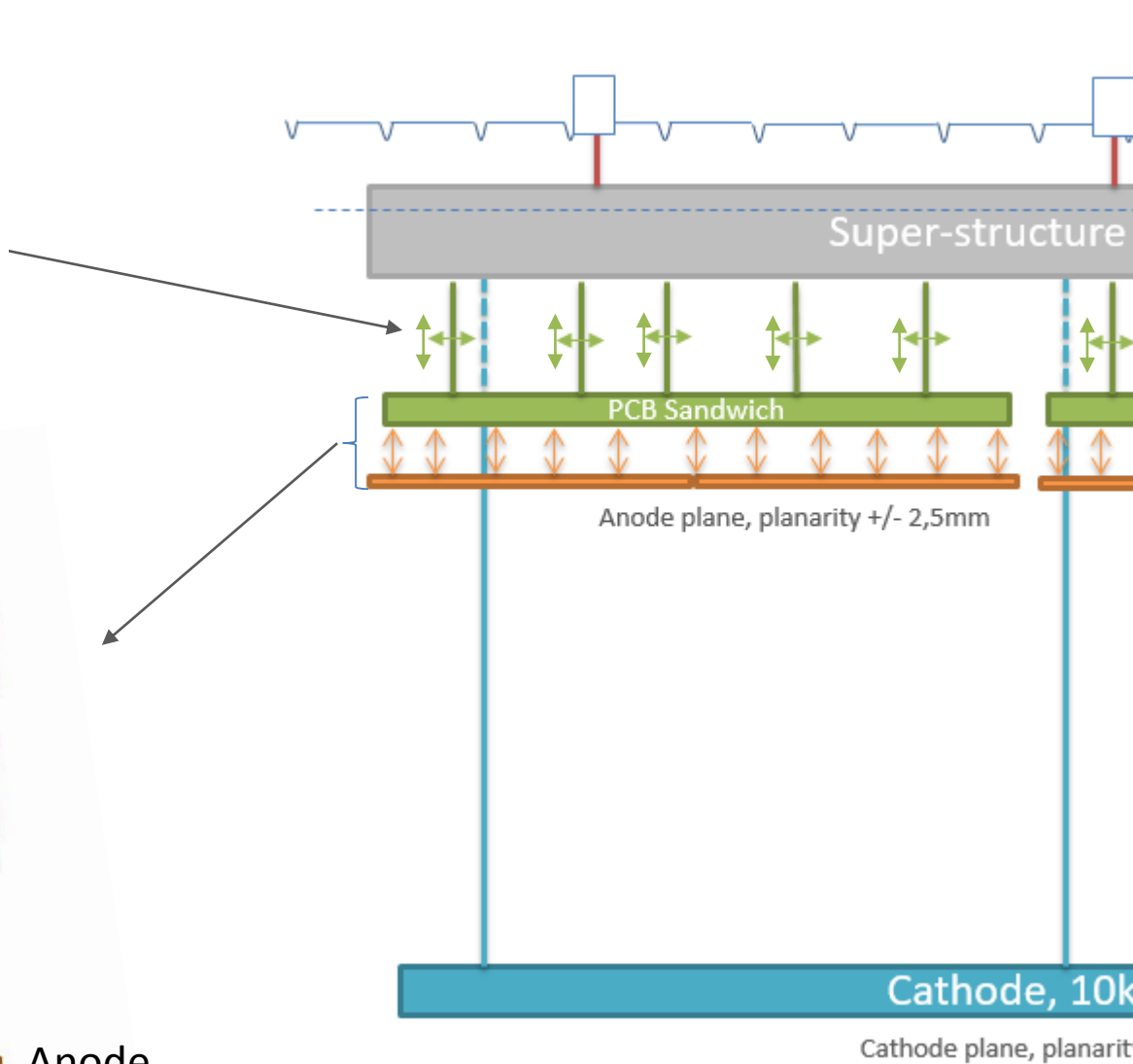

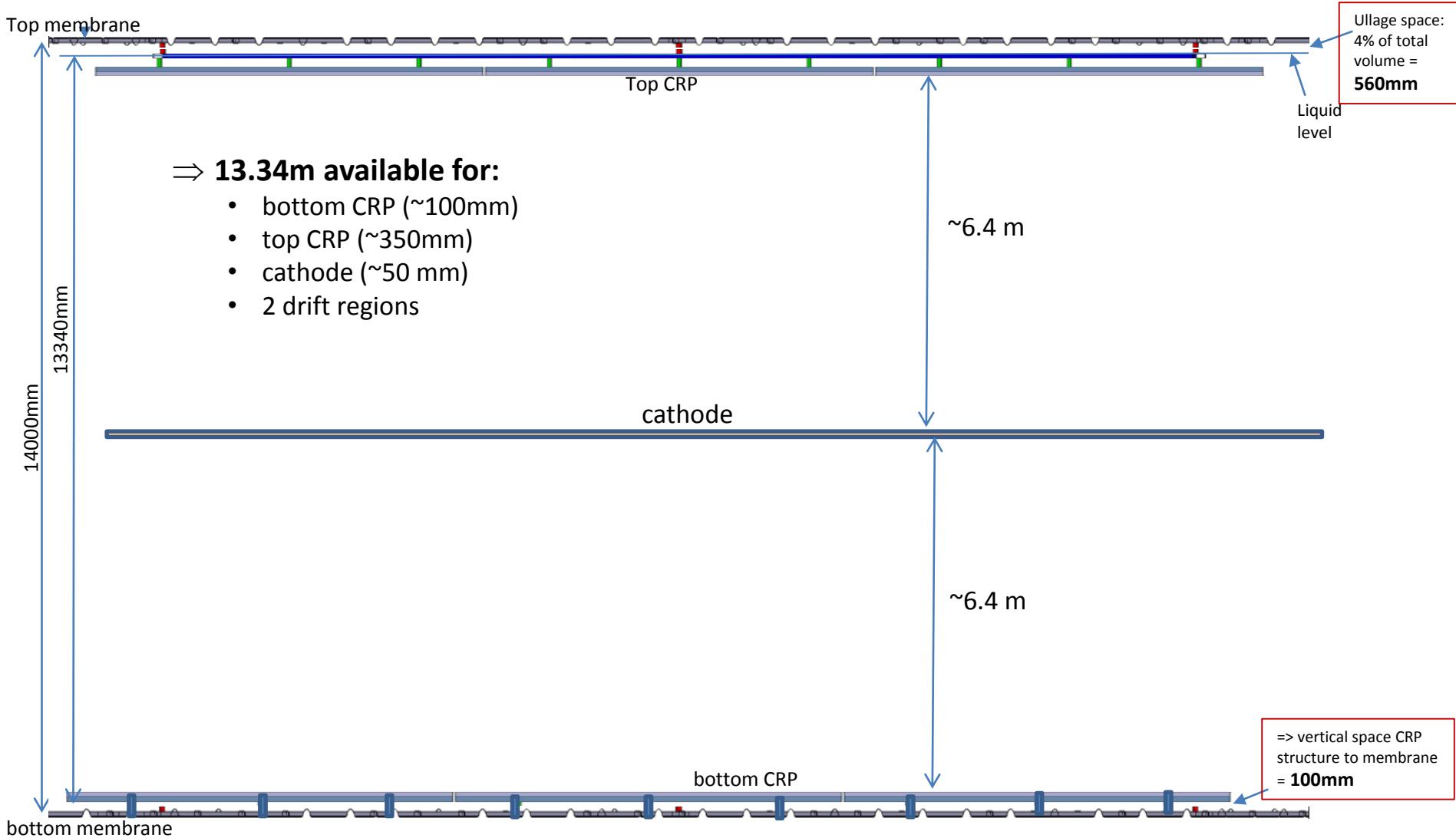

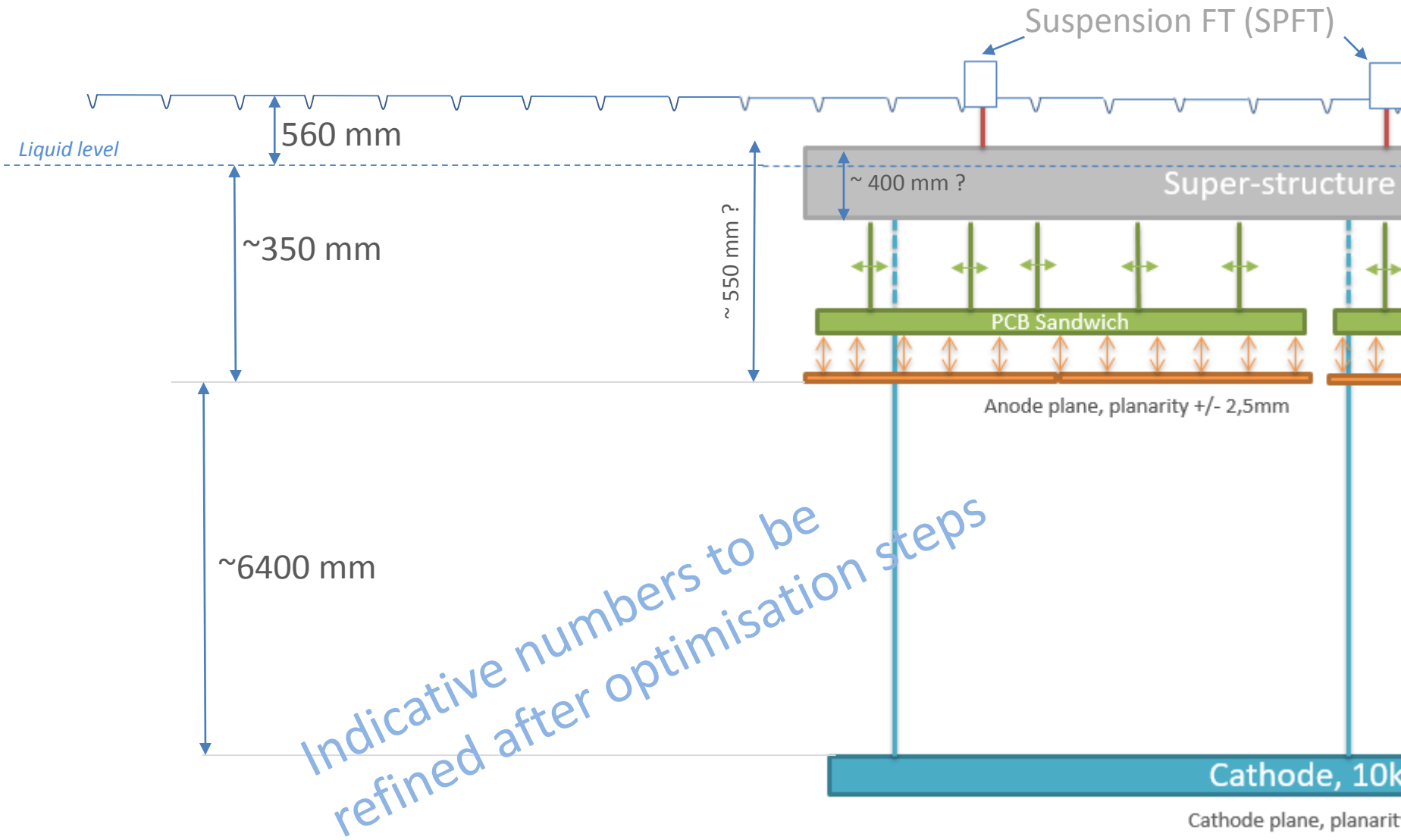

Total detector max length at warm should be 60200mm and a maximal width of 13700mm (to stay within the Field Cage area) => even less to have some clearance with FC

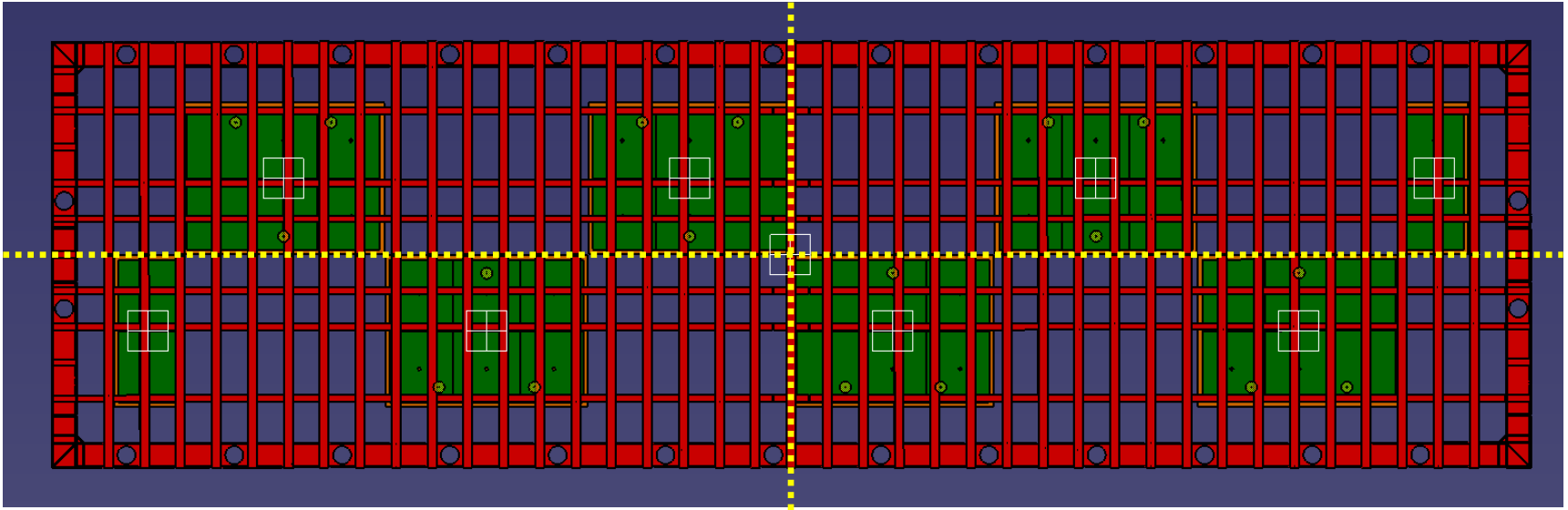

SuperStructure type 1 (x12)

SuperStructure type 2 (x4)
(proposal)

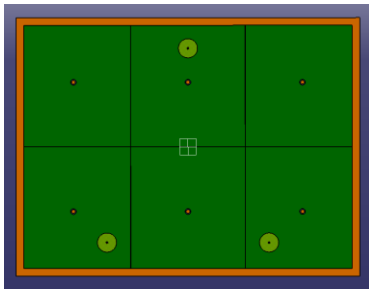

6 CRPs

Functional clearances used for this work:

Inside Super-structure : **2mm** between CRPs

Inter super-structure: **20-40 mm (for the moment)**

=> it adds +140mm along beam direction

=> it adds +24mm along transverse direction

L = 60140 mm (clearance to be studied)

W = 13530 mm ✓

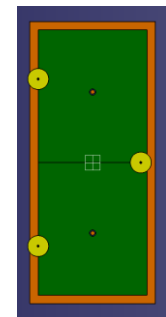

2 CRPs instead of 4

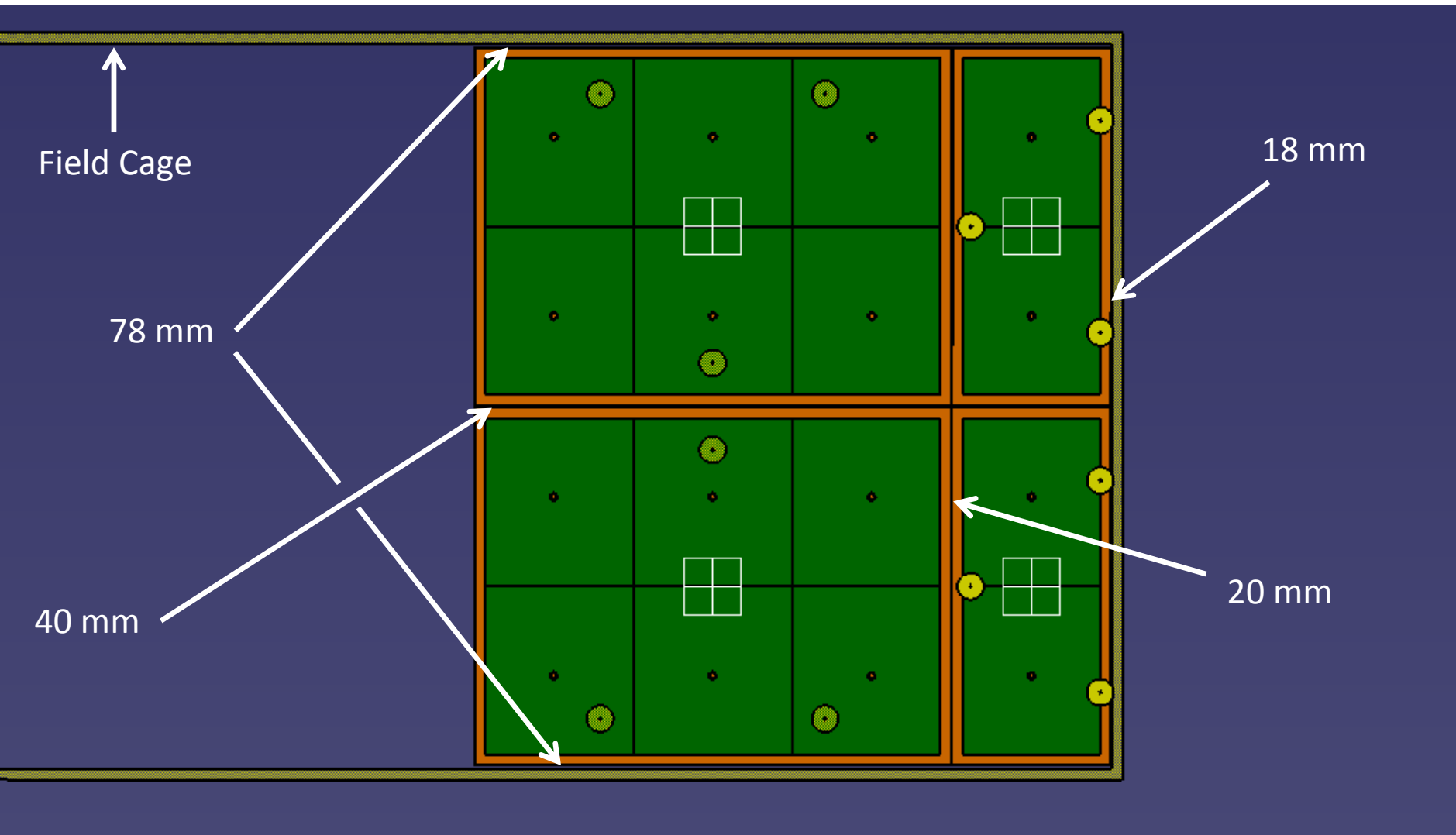

Clearance between SuperStructure and Field Cage is small along longitudinal axis

Superstructure: Invar

CRP: PCB material

(comparison with Stainless steel Superstructure material under progress)

Gaps due to thermal shrinkage are uniformly distributed if functional clearances between Superstructures are kept minimal

Sketch of the complete VD area

WARM

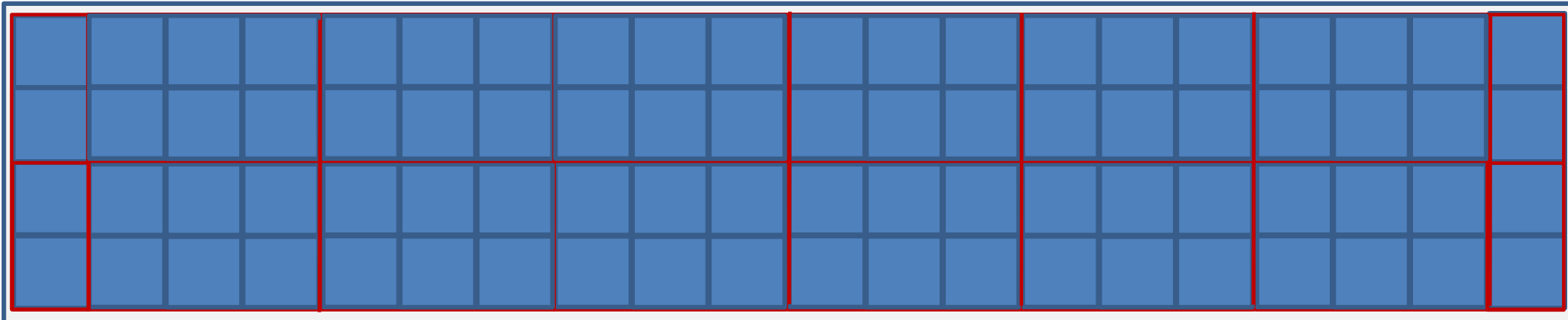

COLD

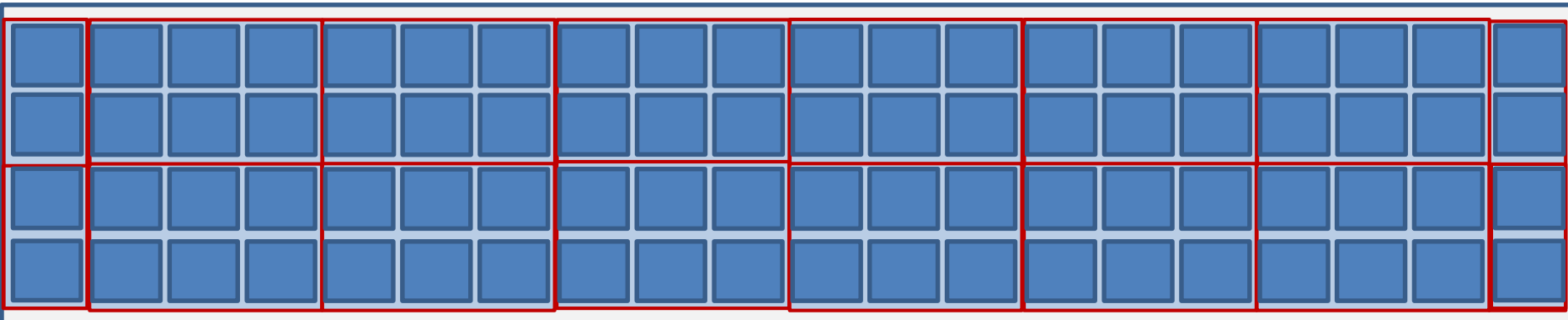

Each interCRP gap increases by about 4mm inside a superstructure and by 7 mm inter Superstructure

– More details in following slides

WARM

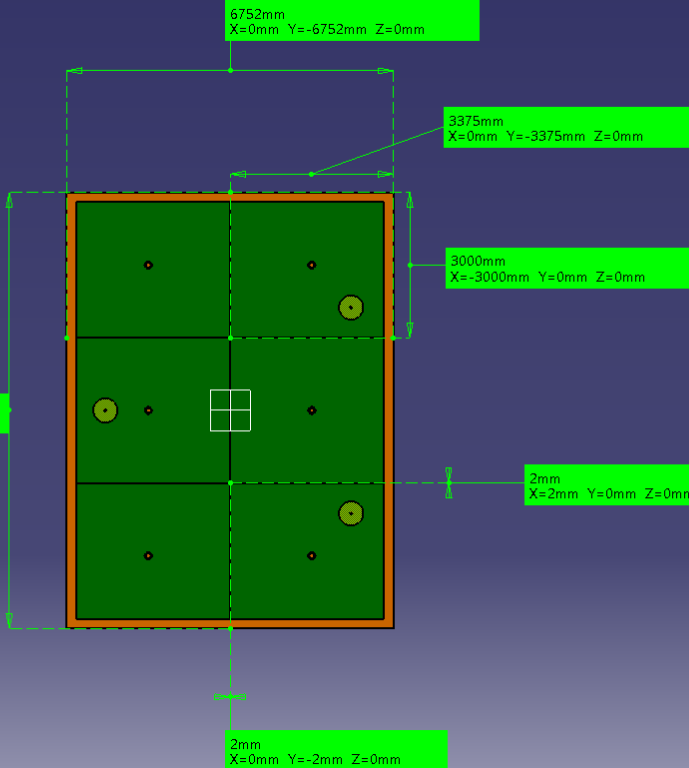

- Each **individual CRP** shrinks by about 5-6 mm
- Inter CRP gaps increase from 2mm to 6mm within a superstructure

COLD

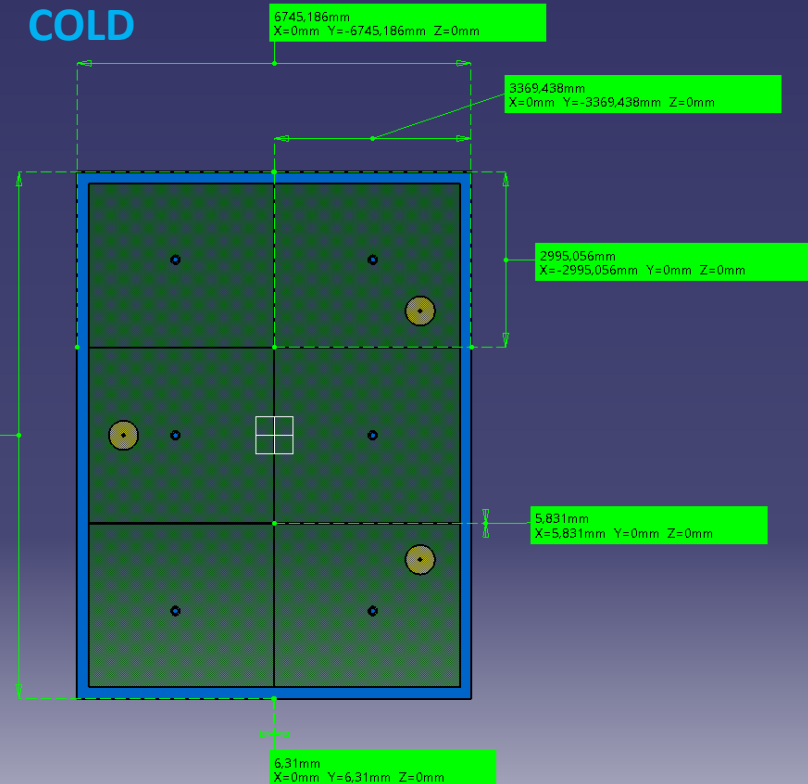

Thermal shrinkage (**external anode plane dimensions** of a full superstructure) :

$$\Delta(\text{length}) = 7,17 \text{ mm}$$

$$\Delta(\text{width}) = 6,81 \text{ mm}$$

Illustrated gaps are distances between anodes of 2 consecutive SuperStructures

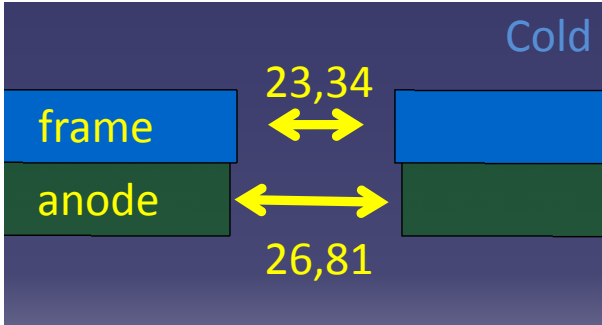
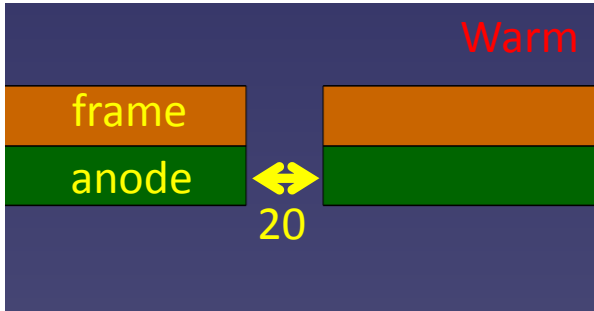

The 20mm functional clearance needs to be fine tuned to allow enough for installation and cope with the field cage area

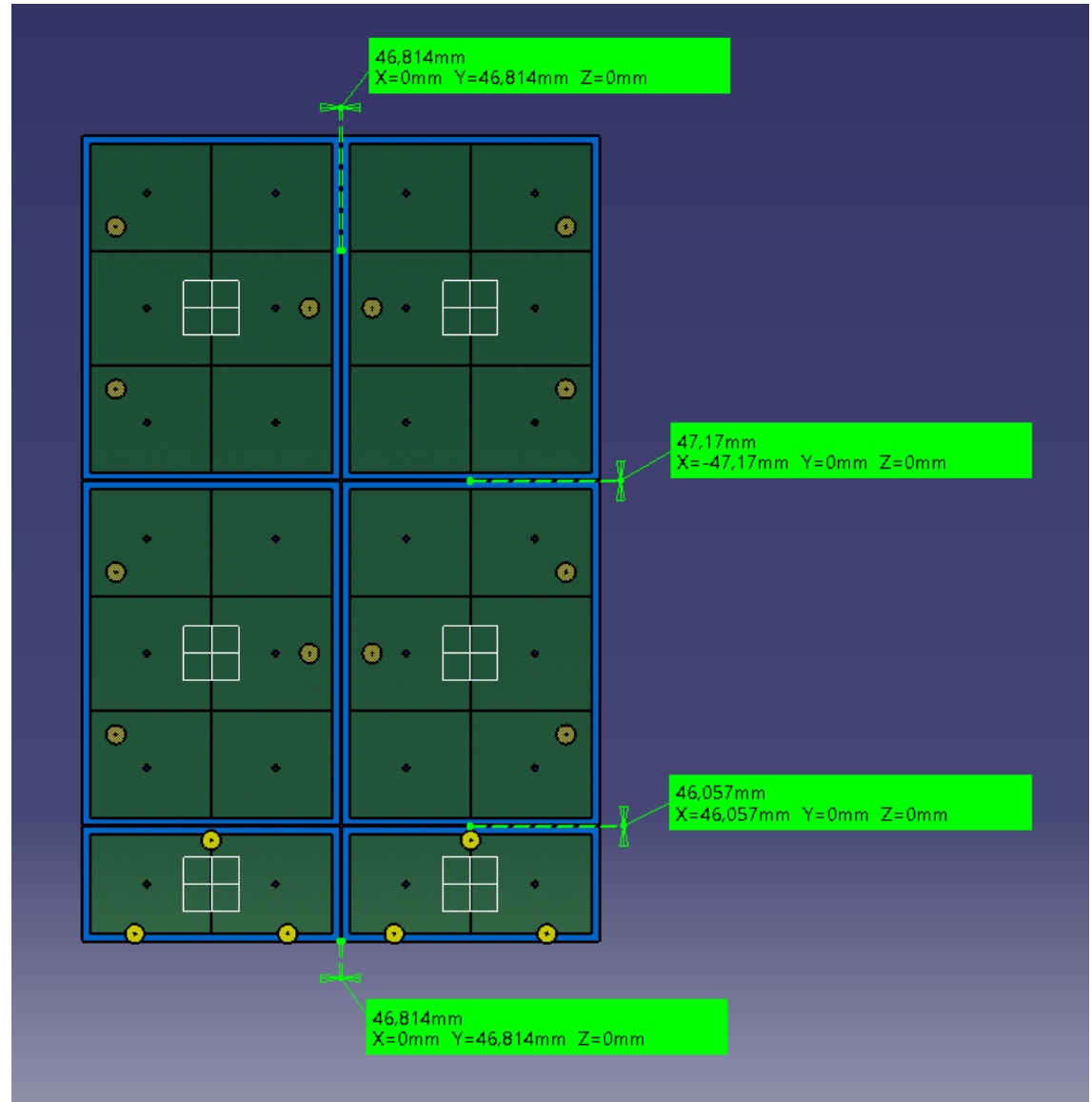

Possible positions of SPFT – Fonctionnal clearance defines SPFT positions
(yellow circles diameters are arbitrary - just for eye guidance)



In order to **avoid interference with cryostat structure**, the position of suspension cables will have to be adjusted
 (the optimal would have been to **have the triangle centered wrt SSt**) but not possible with actual cryostat layout

- If the displacement is unavoidable => to be optimised in the calculations for the 3 suspensions to allow enough space between the SPFT and the cryostat structure.
- The superstructure asymmetric deformation will be treated at installation in that case

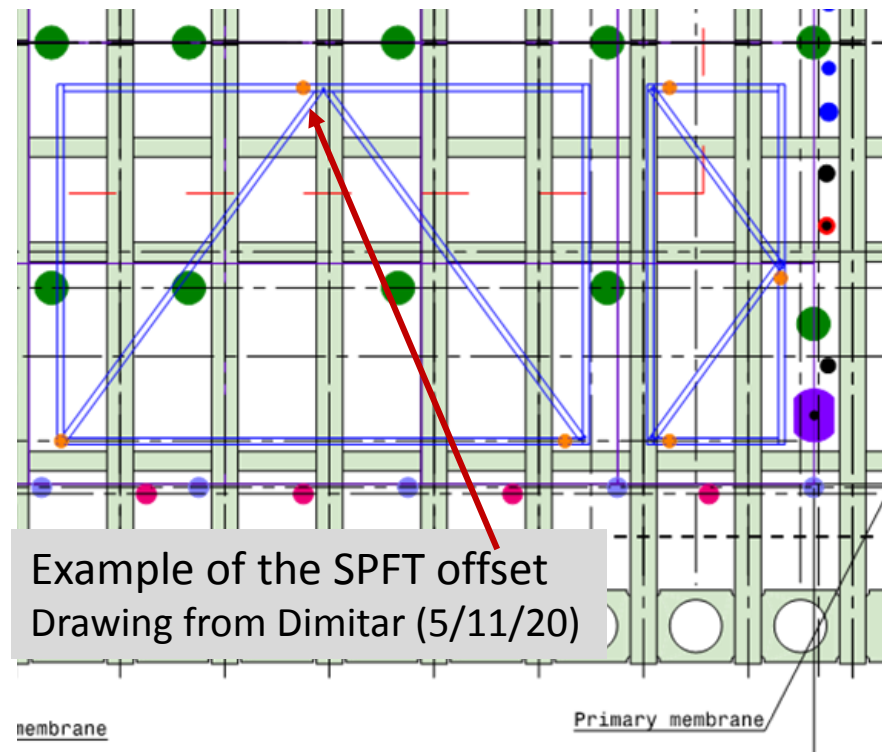
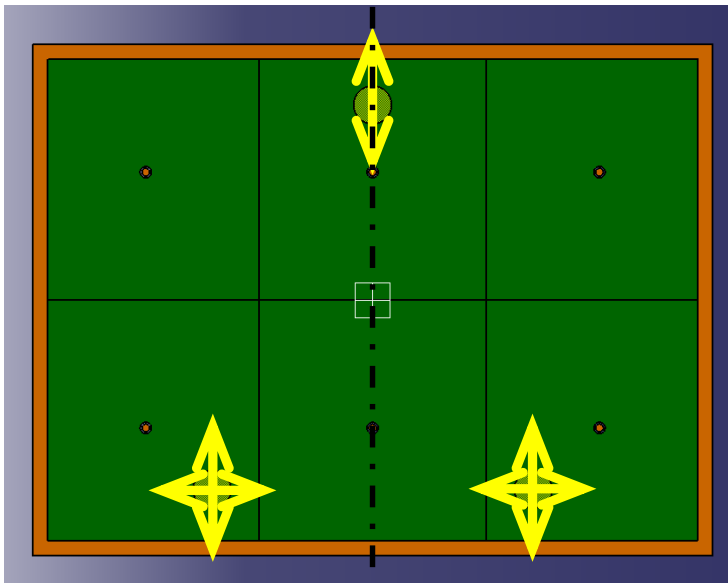

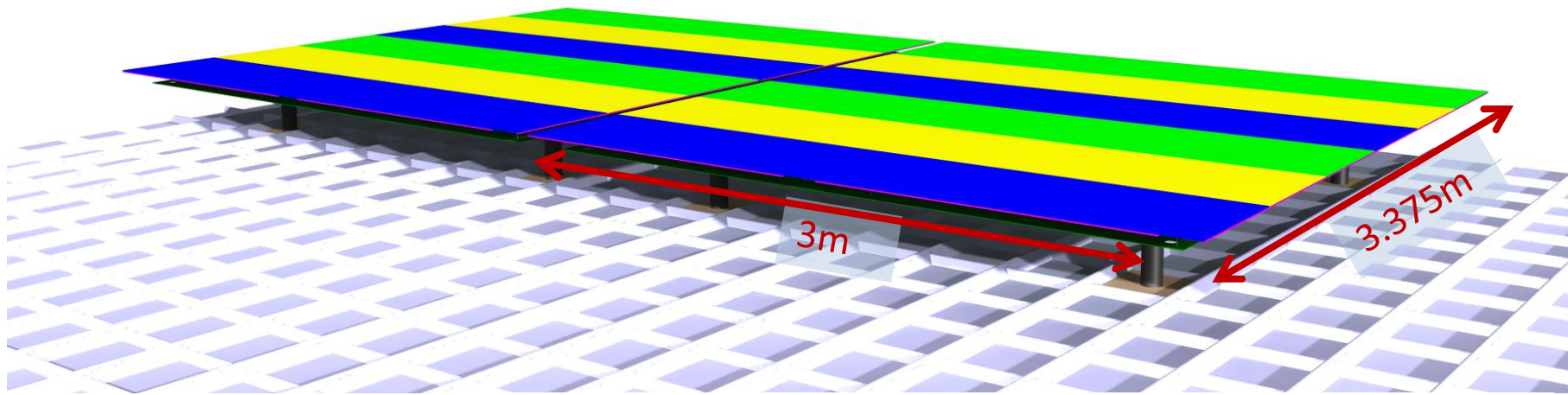

**Individual CRPs structure
is identical to Top-plane**

- Consists of 4 anodes planes
- 3000 x 3375 mm
- Supporting PCB sandwich frame

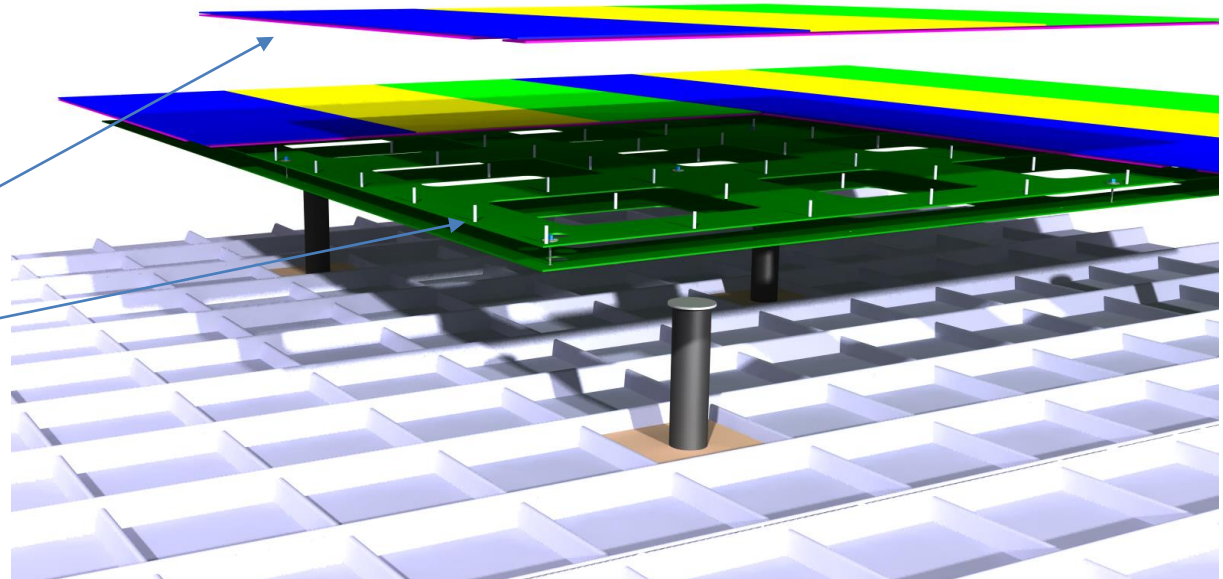

Lateral decoupling
(PTFE, bearing, ...)

Vertical adjustment

Only laid on the membrane
No fixation, no sliding on the membrane

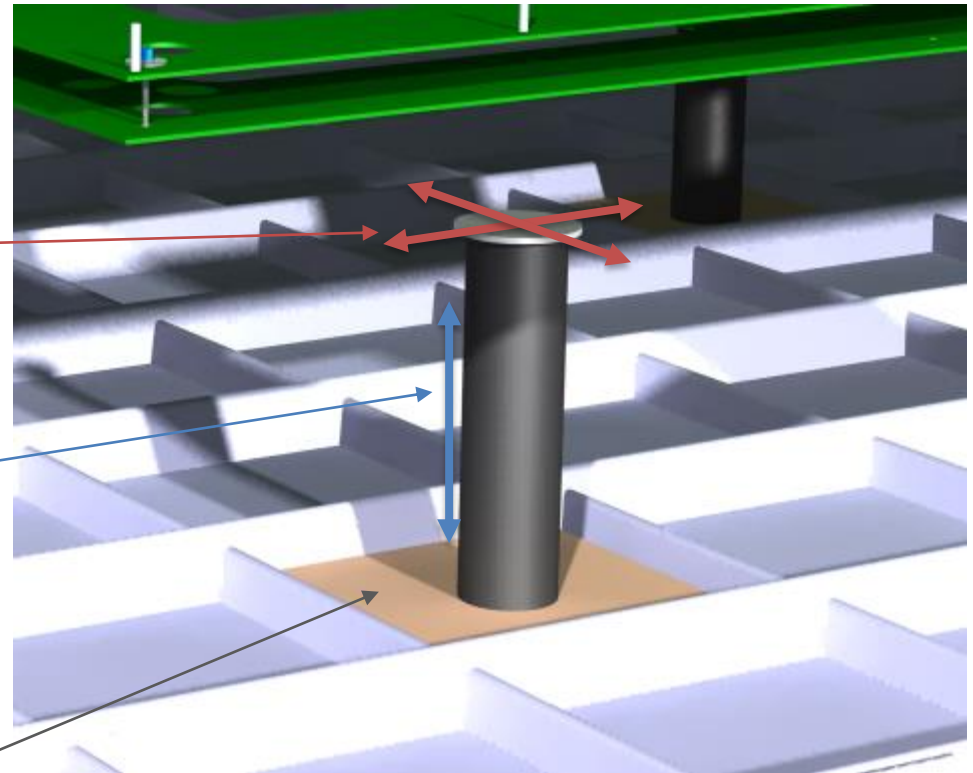

Thermal contraction pattern is identical to Top-Plane, based on the membrane

« Squares » of the membrane are contracting around their own center

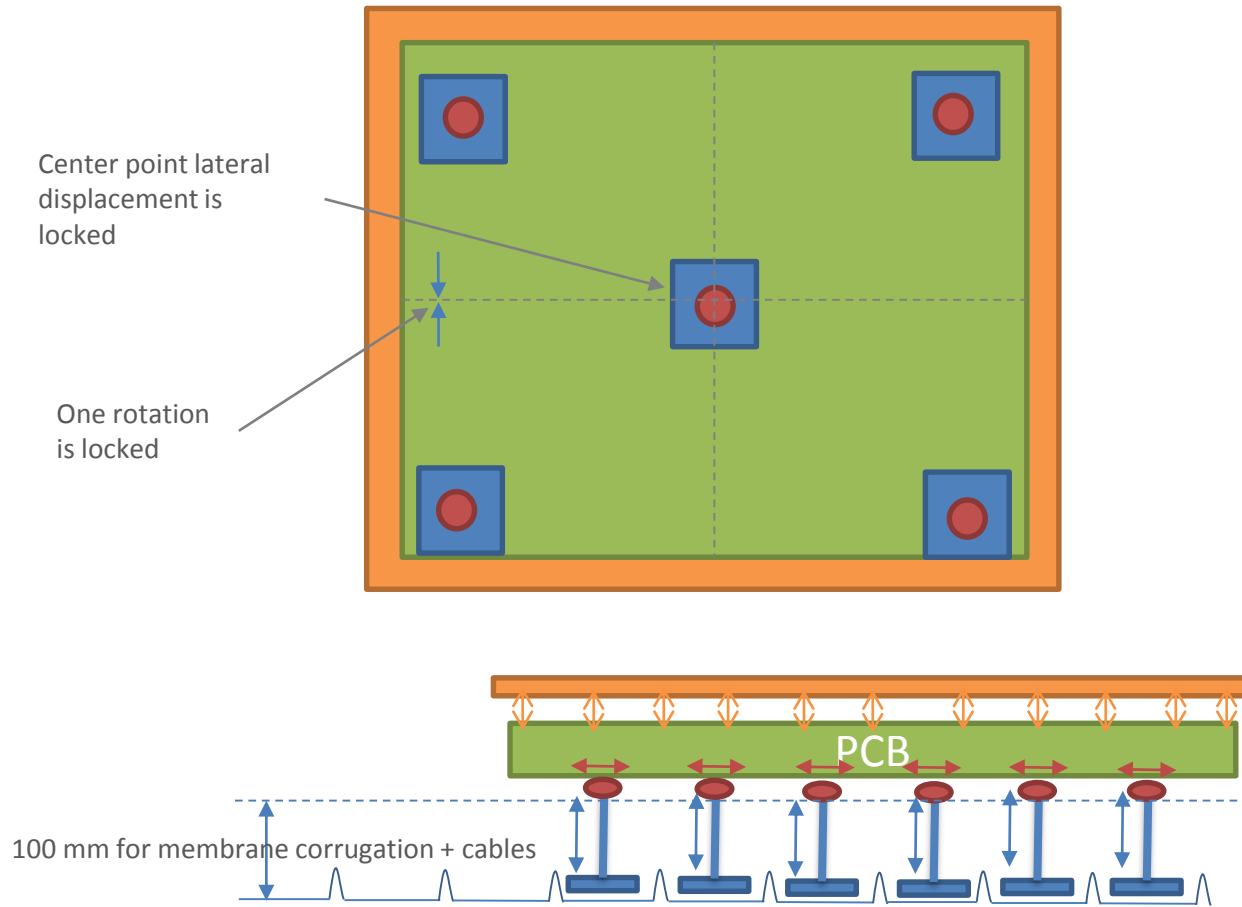

Mechanical simulations

1. Anode attachment points
2. PCB support frame
3. Super-CRP structure

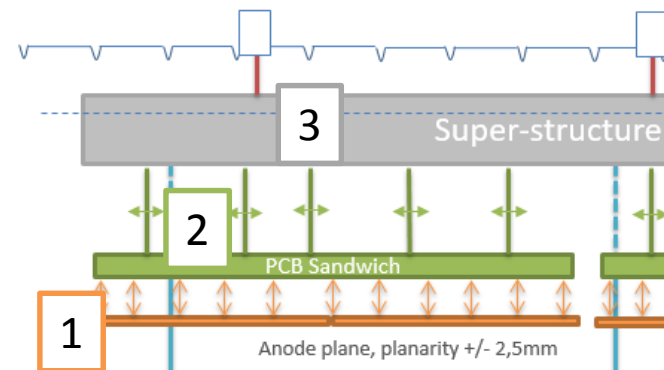

- Young Modulus adaptation : **3390 MPa** (26400 MPa for initial material in Ansys library)
- To be confirmed and validated with real tests (to discuss with PCB suppliers)

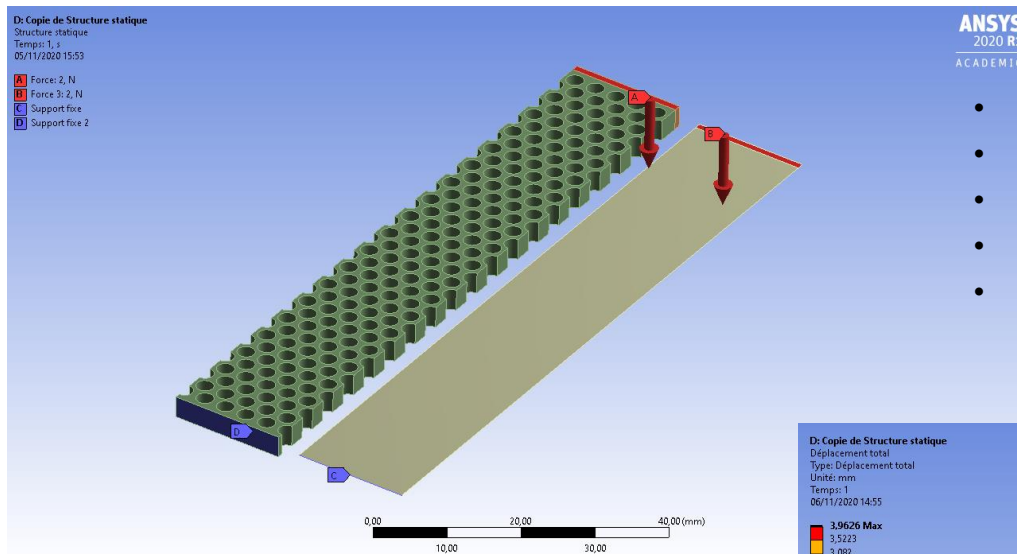

- Dimensions : 1500 x 1680 (=3x0,56) x 3,2 mm
- PCB initial density : 1850 kg/m³
- PCB corrected density for anode simulation : 1424,32 kg/m³
- Corrected Young Modulus : **3390 MPa** (26400 for initial material)
- Anode Mass for a 3000 x 3375 mm plane : **46 kg**

Hole pattern as tested on small scale proto at CERN

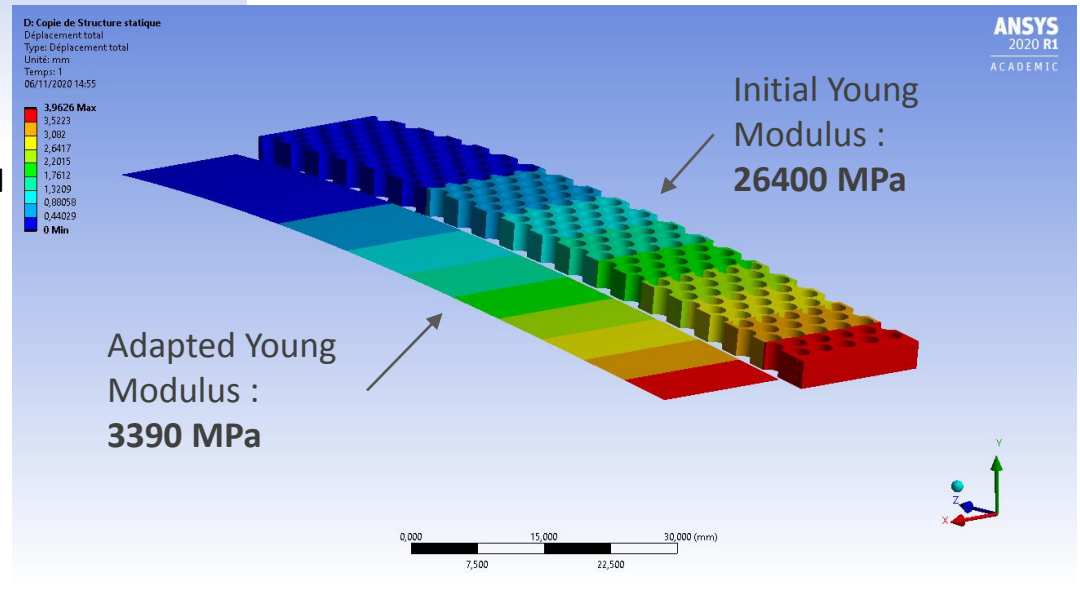
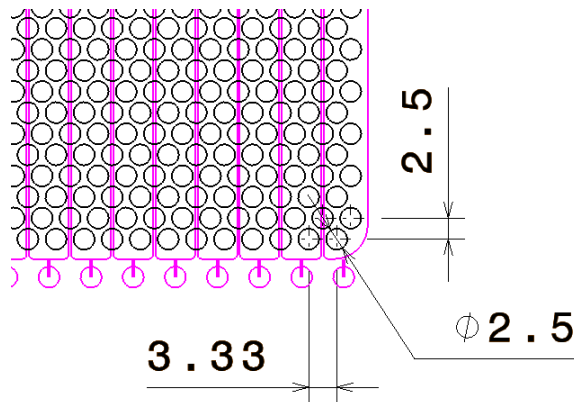

Initial configuration :

-> 1,5m x 1,68m anode plane, supported by 36 uniformly distributed screws

- Max displacement : 0,3 mm
- Average displacement : 0,15 mm (similar along borders)

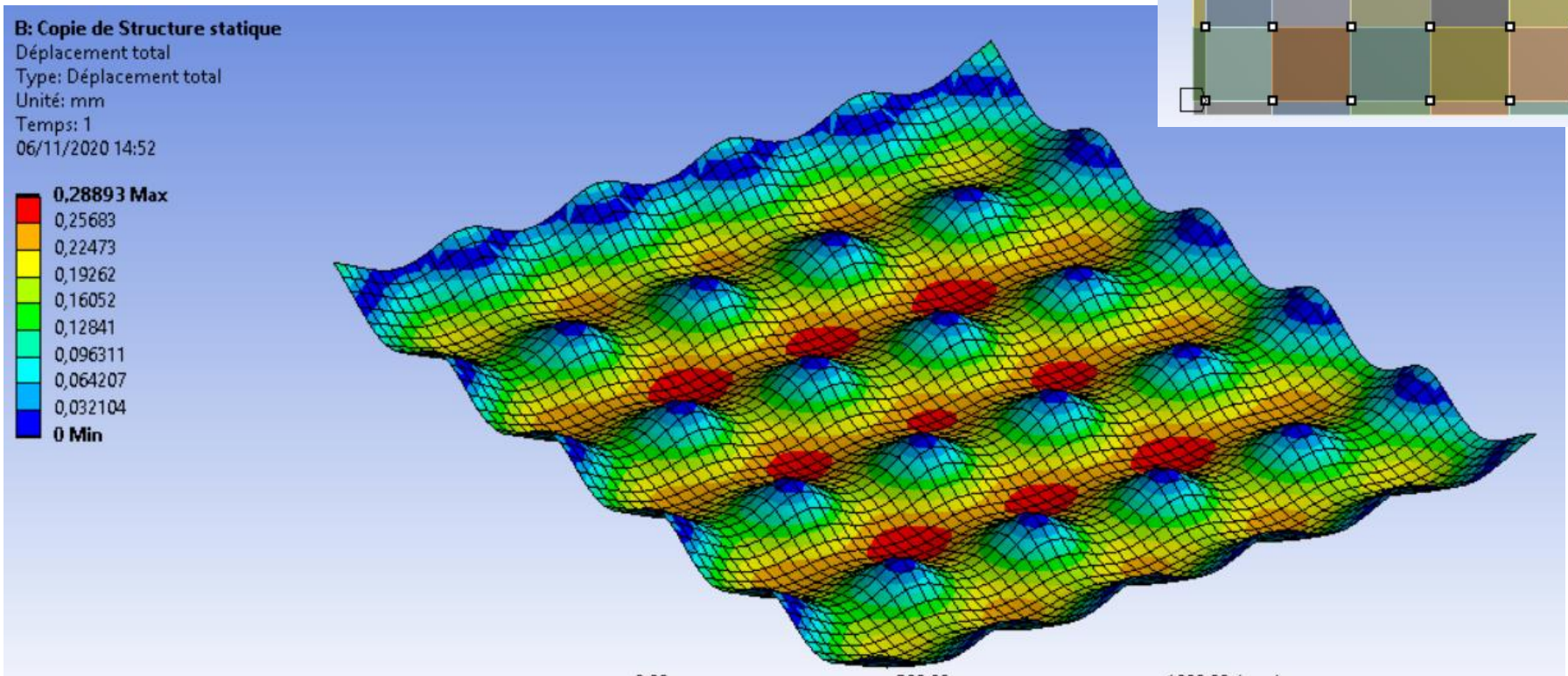
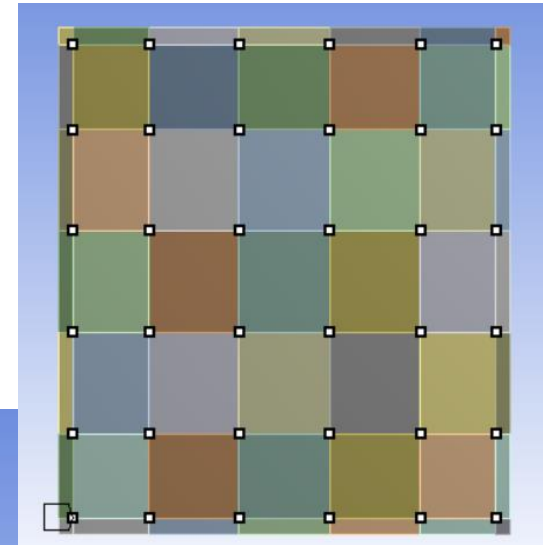

Bo suggestion from 9/11/2020 : 37 suspension points, higher density along borders

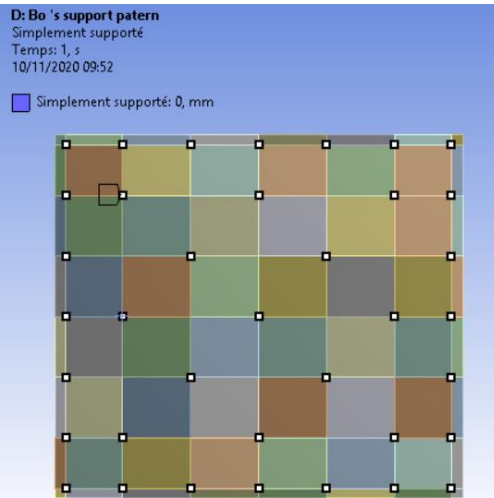
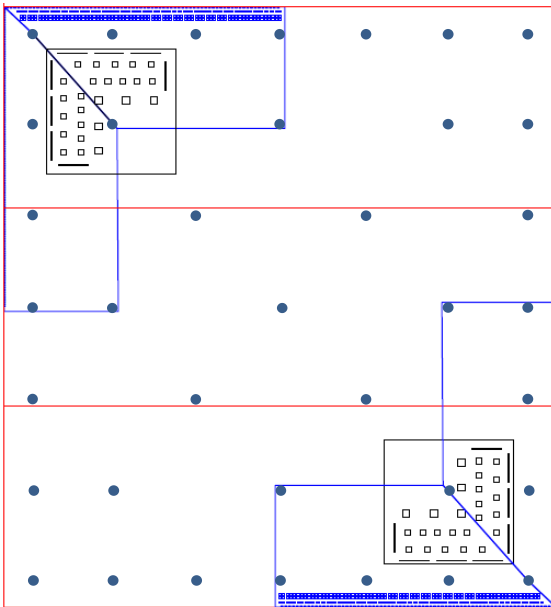

D: Bo 's support patern
 Déplacement directionnel
 Type: Déplacement directionnel(Axe Z)
 Unité: mm
 Système de coordonnées global
 Temps: 1
 10/11/2020 09:50

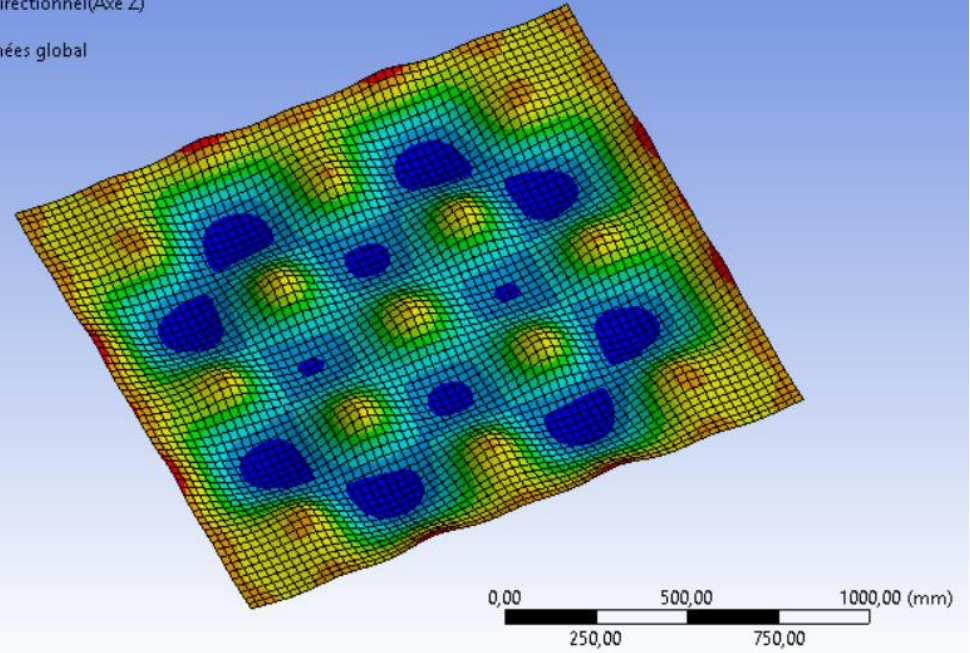
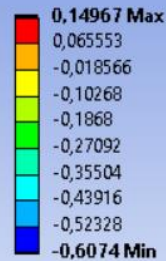

Results :

- Max displacement (planarity deviation) : 0,75 mm
- Less than 0.2mm on the borders

Has to be refined with exact screws positions

Pattern to be discussed to conciliate electronics and deformations

the electronic adapter boards to be included in a next step

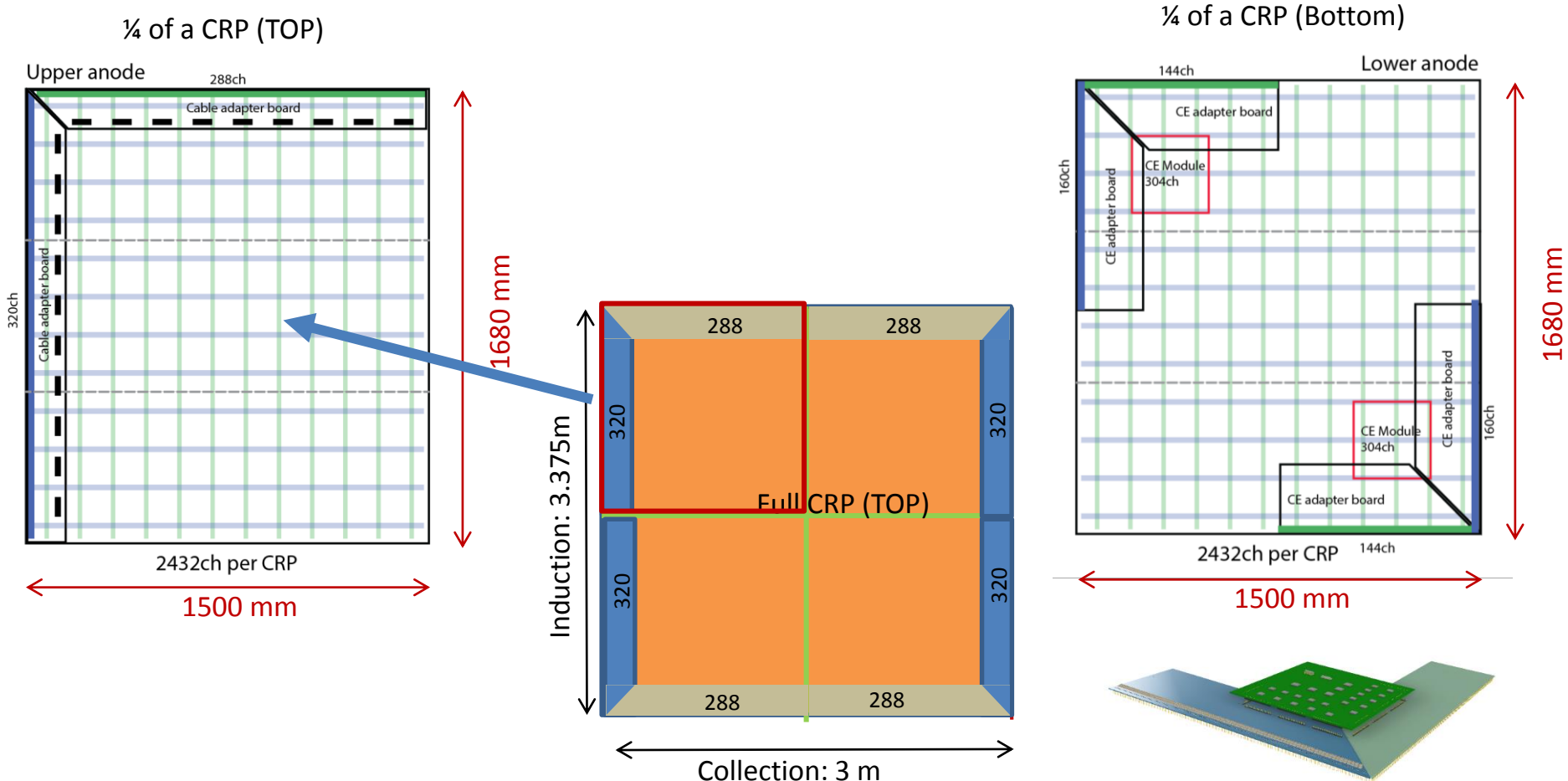

In contact with Bo to integrate the design

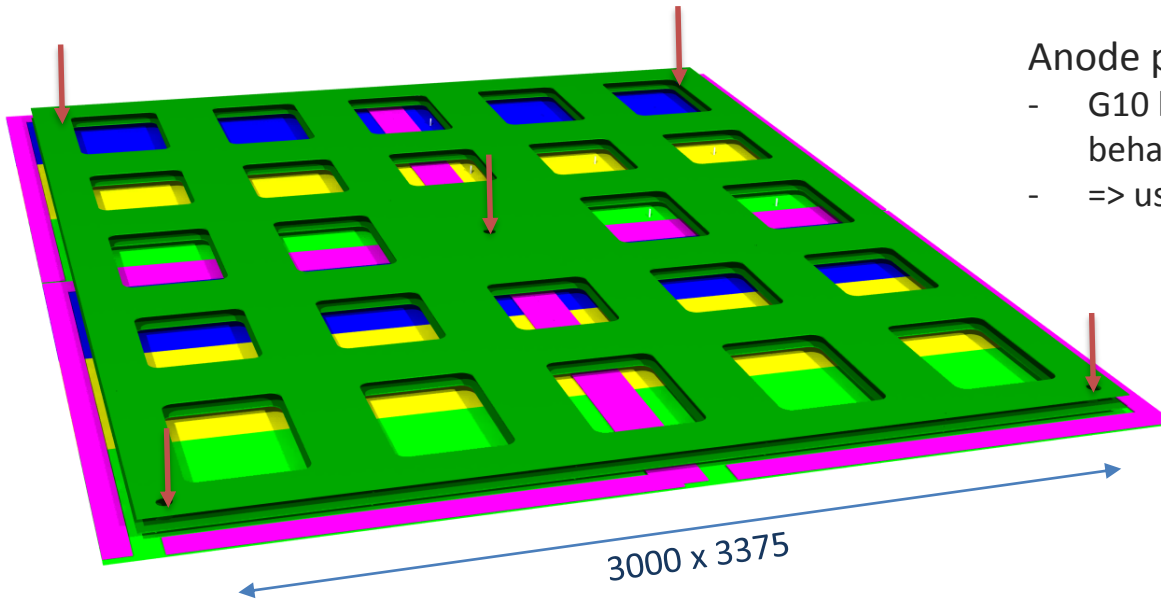

Anode plane suspended to PCB sandwich

- G10 has different thermo-mechanical behaviour than PCB
- => use PCB to support PCB instead of G10

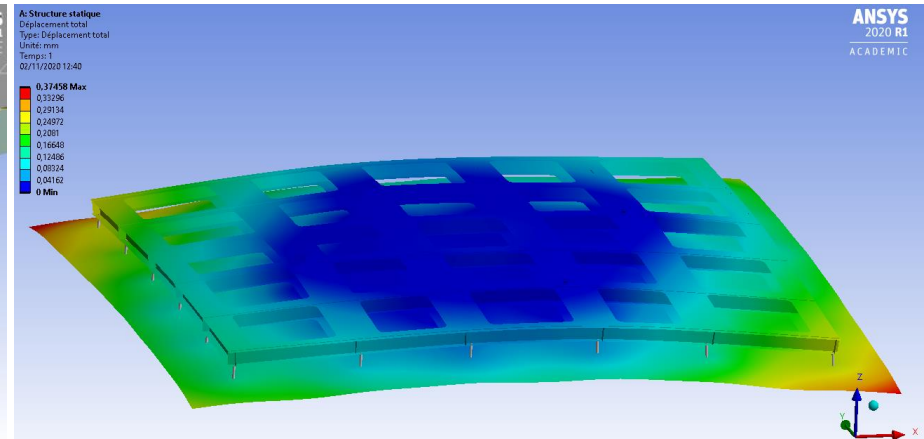
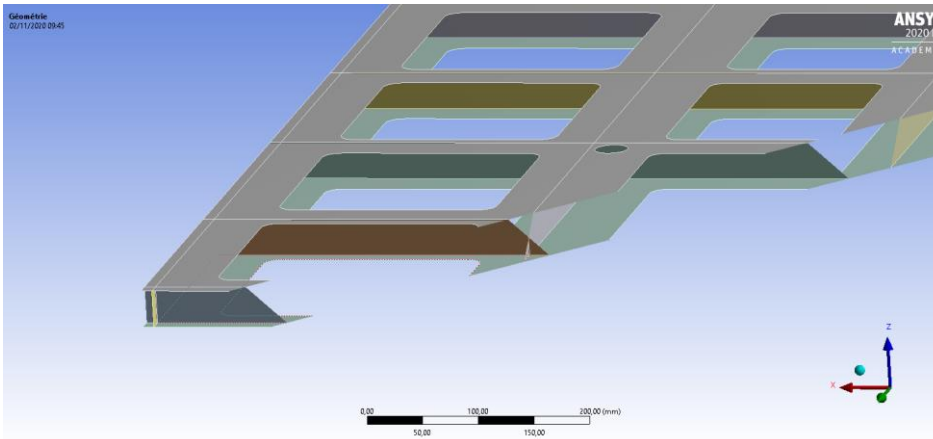

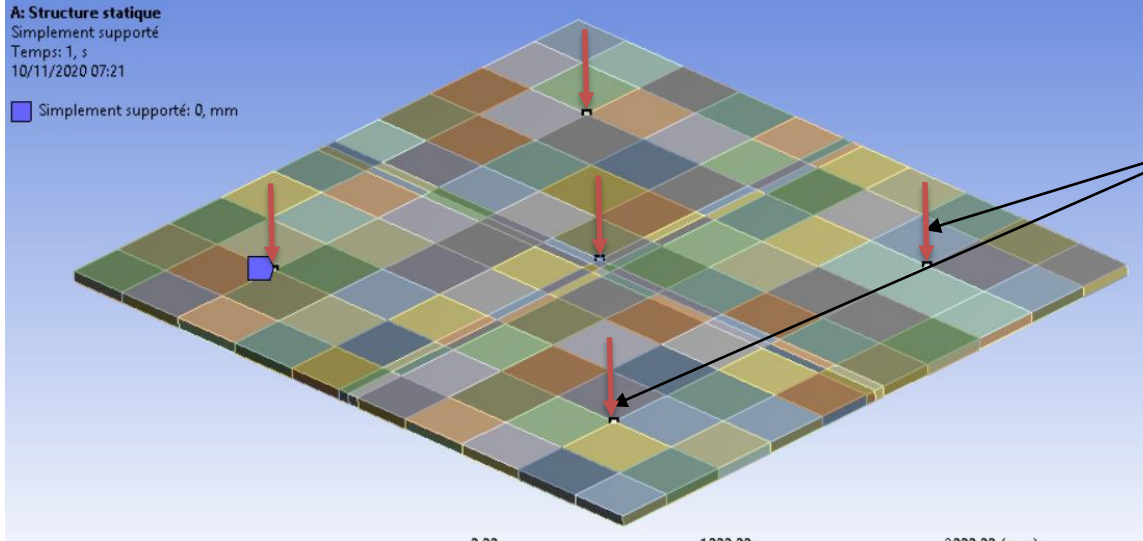

5 Anchoring points to super structure

Considered PCB 's material properties :

- $E = 26400 \text{ Mpa}$
- $\rho = 1850 \text{ kg/m}^3$

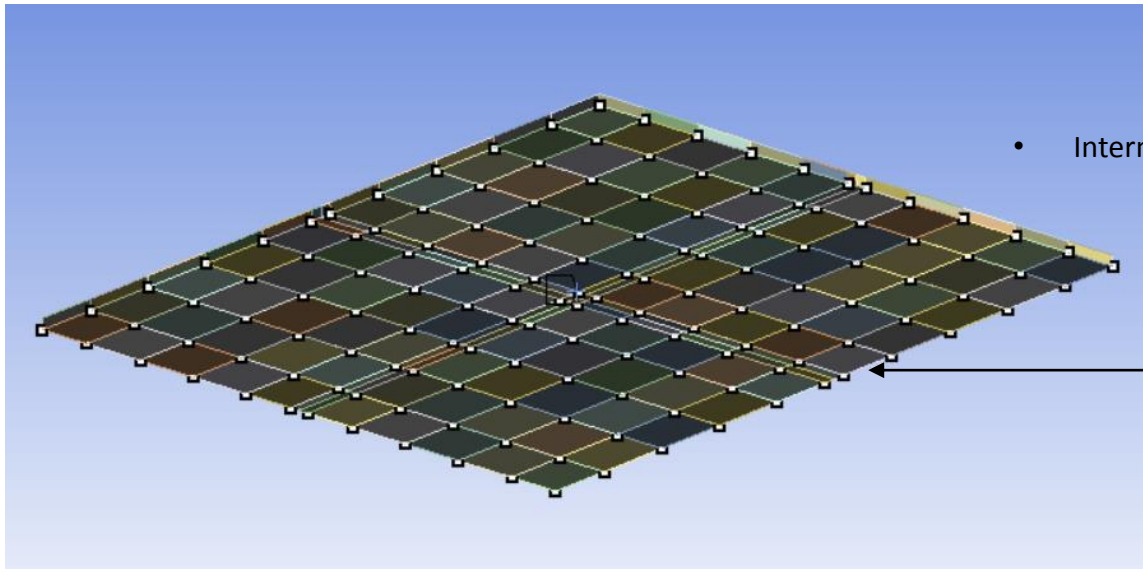
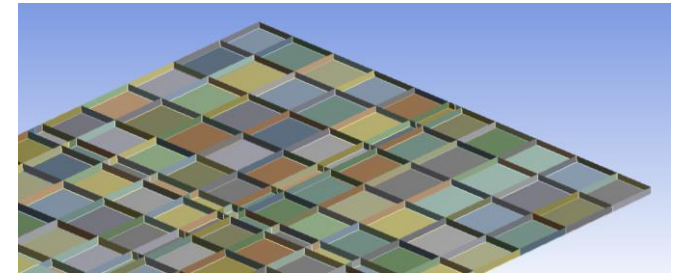

- Internal sandwich structure :
 - 50 mm high vertical stiffeners
 - Pitch corresponding to anode fixation ($\sim 300\text{mm}$)

Loading :

- Gravity
- 451 N Force spread over 144
 (36 x 4) anode suspension points to stand for anode weight

3m x 3,375m PCB supporting structure :

- Max displacement : ~ 0,15 mm
- Weight of the structure : ~120kg, optimisation in progress

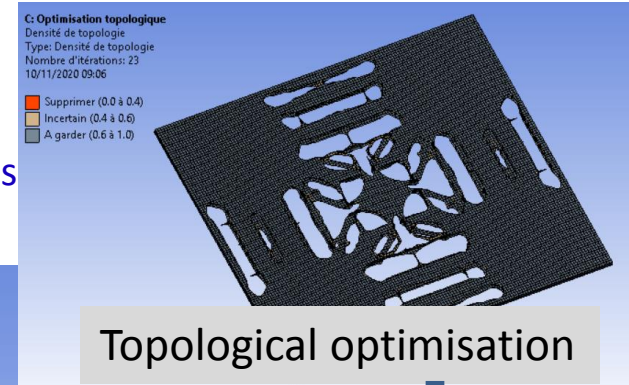
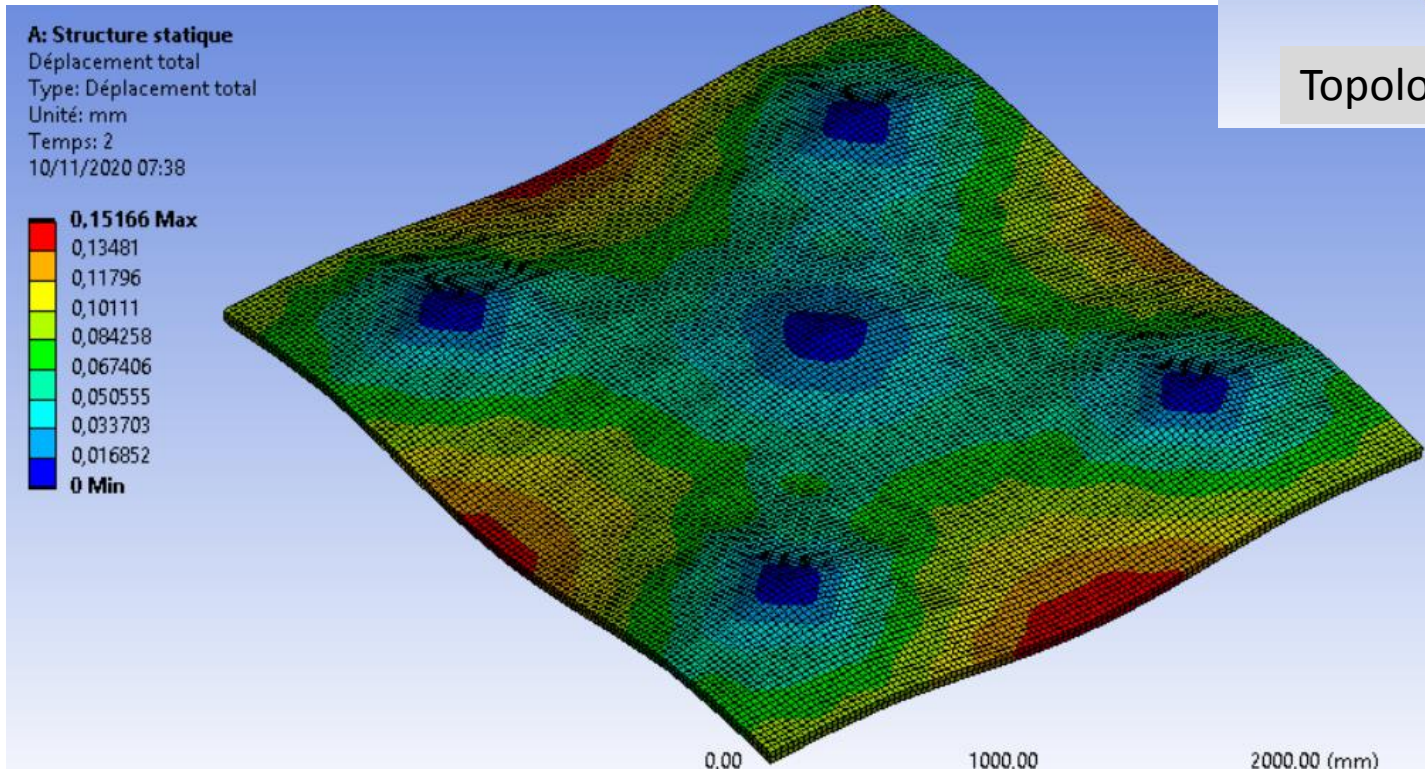

- Can be done to save mass but increases complexity of structure
- Can “drive” location of holes that will be necessary to pass signal cables

Superstructure supporting 6 CRPs

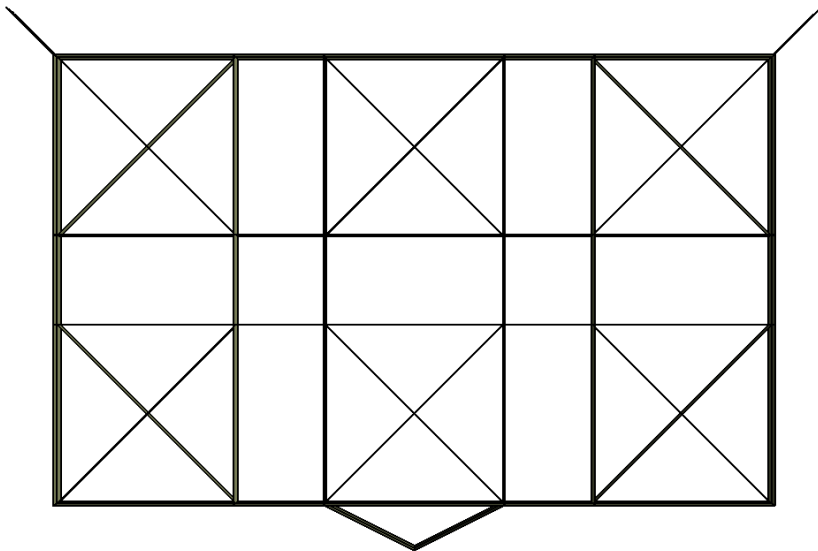
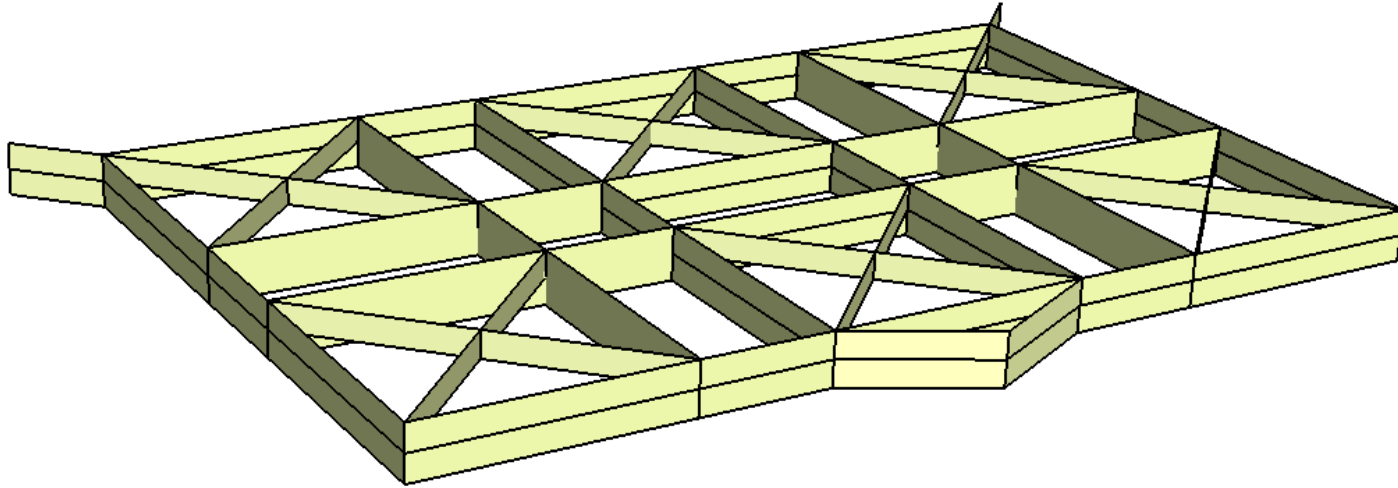

- Dimensions : 8m x 5m
- 2 Heights : 400mm and 200mm (crosses)
- Plates thickness = 6,35mm
- Weight : 1,6 tons

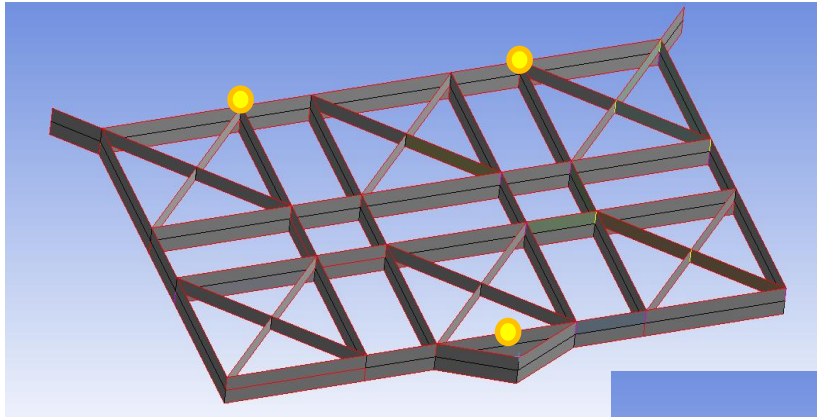

3 suspension points

Cathode is directly connected to the « summit » point

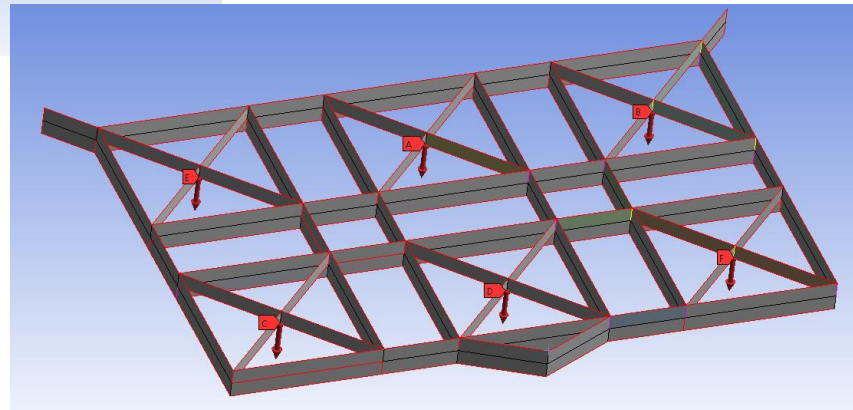
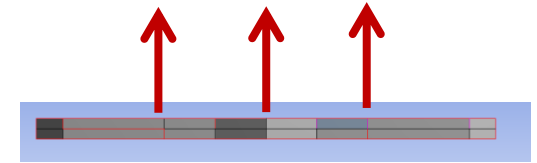

Step 1 : gravity (1,6 tons)

Step 2 : CRPs masses (200kg chaque)

Step 3 : Cathode mass (200kg x3)

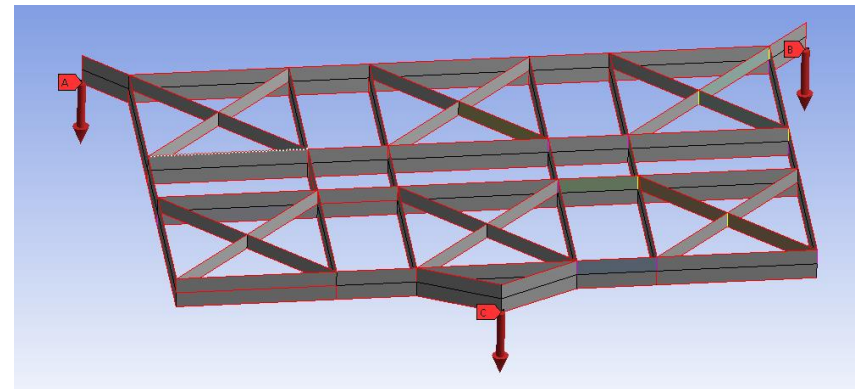

Thickness = 6.35mm

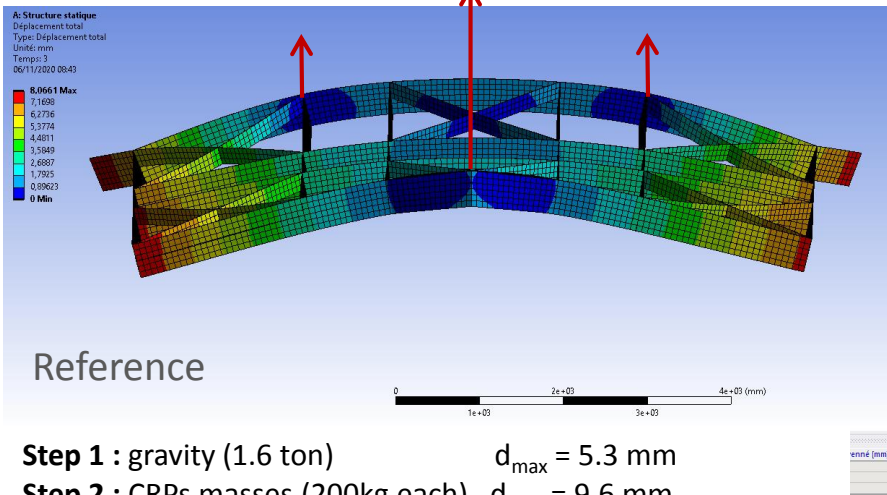

Reference

- Step 1** : gravity (1.6 ton) $d_{max} = 5.3 \text{ mm}$
- Step 2** : CRPs masses (200kg each) $d_{max} = 9.6 \text{ mm}$
- Step 3** : Cathode mass (200kg x3) $d_{max} = 8.1 \text{ mm}$

Thickness = 4mm

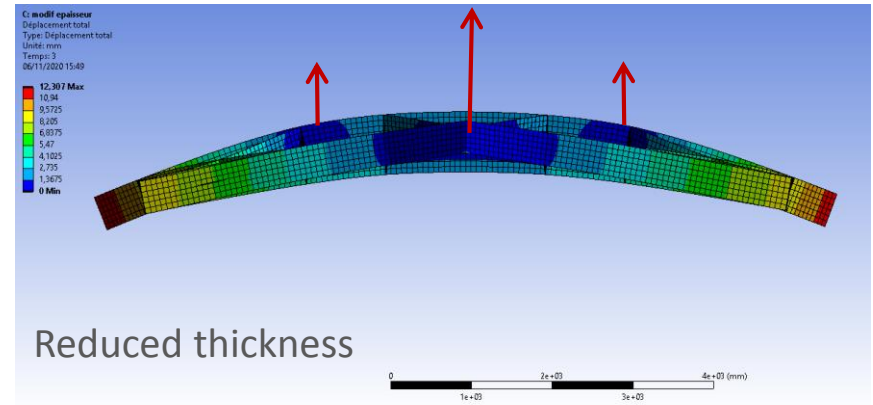

Reduced thickness

- Step 1** : gravity (1ton) $d_{max} = 5.3 \text{ mm}$
- Step 2** : CRPs masses (200kg each) $d_{max} = 12.2 \text{ mm}$
- Step 3** : Cathode mass (200kg x3) $d_{max} = 12.3 \text{ mm}$

Thickness = 6.35mm and Top triangle suspension shifted by 100mm

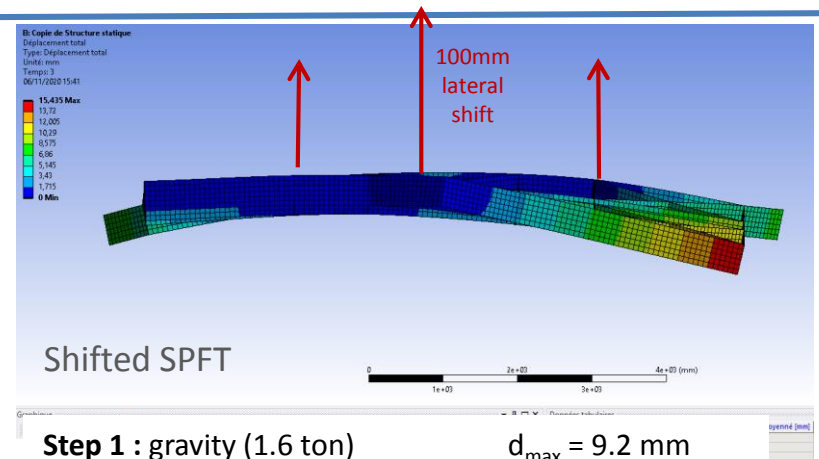
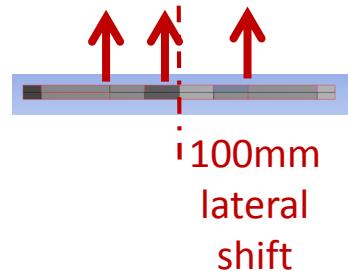
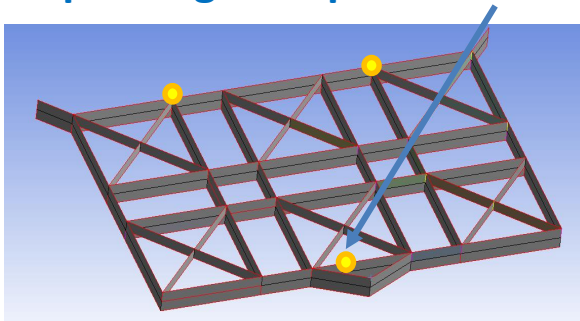

Shifted SPFT

- Step 1** : gravity (1.6 ton) $d_{max} = 9.2 \text{ mm}$
- Step 2** : CRPs masses (200kg each) $d_{max} = 16.2 \text{ mm}$
- Step 3** : Cathode mass (200kg x3) $d_{max} = 15.4 \text{ mm}$

	Reference	Reduced thickness	Shifted anchoring
Gravity:	$d_{\max} = 5.3 \text{ mm}$	$d_{\max} = 5.3 \text{ mm}$	$d_{\max} = 9.2 \text{ mm}$
CRP masses:	$d_{\max} = 9.6 \text{ mm}$	$d_{\max} = 12.2 \text{ mm}$	$d_{\max} = 16.2 \text{ mm}$
Cathode masses :	$d_{\max} = 8.1 \text{ mm}$	$d_{\max} = 12.3 \text{ mm}$	$d_{\max} = 15.4 \text{ mm}$

- Immersion effects (Archimède) have to be estimated
- More optimisation will be performed on this structure
- Other design with stainless steel on going: first calculations performed

This is a first design work on the CRP structures for VD detector:

- Preliminary optimisation and calculations on anode, PCB frames and superstructures have shown results matching the defined criteria (at least for the symmetric suspended SuperStructure design)
- CRP mechanical structures are identical between bottom and top
- More optimisation and refinements needed and on going
- Alternative structure material options are also considered and studied for the superstructure (SS)
- Detailed definition of the CRP suspension points with cryostat feedthroughs positions in progress
- Work on interface with cathode mechanical structure has started for the cathode frame suspension

Critical aspects to work on:

- Overall anode and superstructure dimensions in the cryostat to fit the area of the field cage
- Given the large SuperStructure dimensions and weights: important to asses reasonable functional clearances especially for installation => it cannot be only a few mm!
- Gaps needed for the cathode suspension to consider

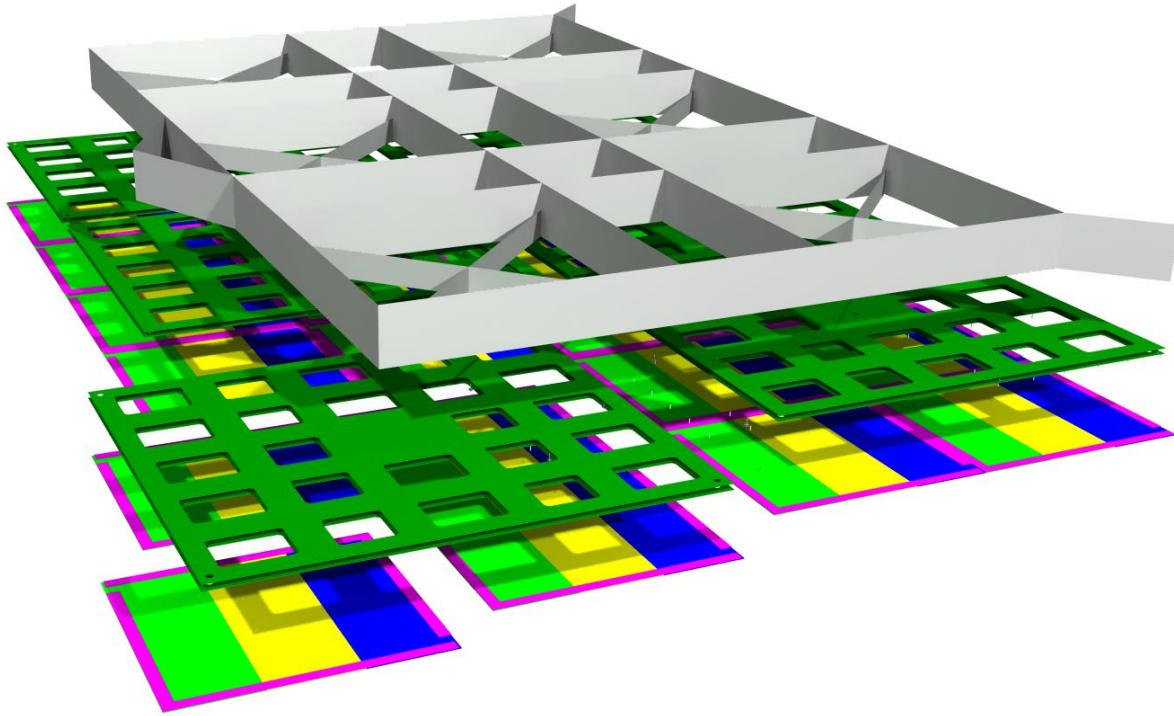

End

Superstructure: Invar CRP: PCB

Scénario A:

Locked points on the structure

WARM

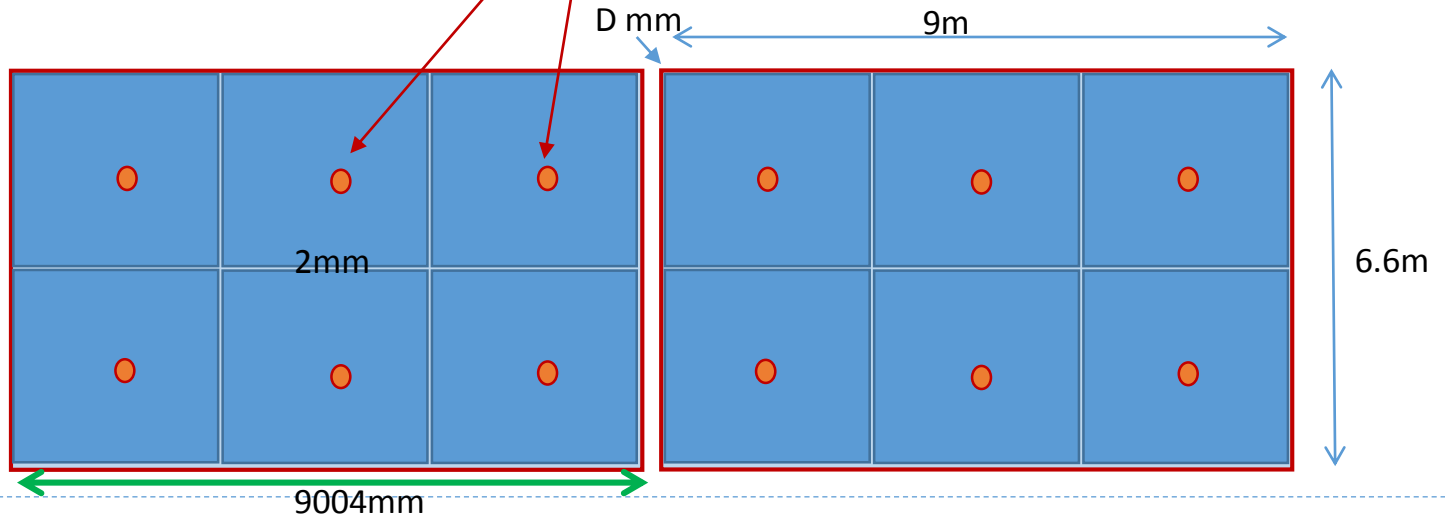

COLD

Each interCRP gap increases by about 6mm

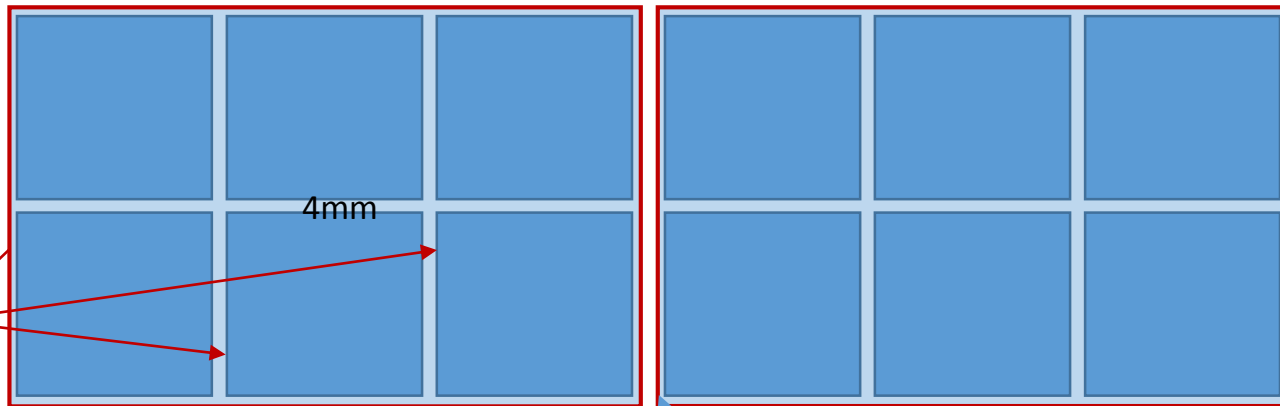

Sketch of 2 neighbouring superstructure

D+7 mm

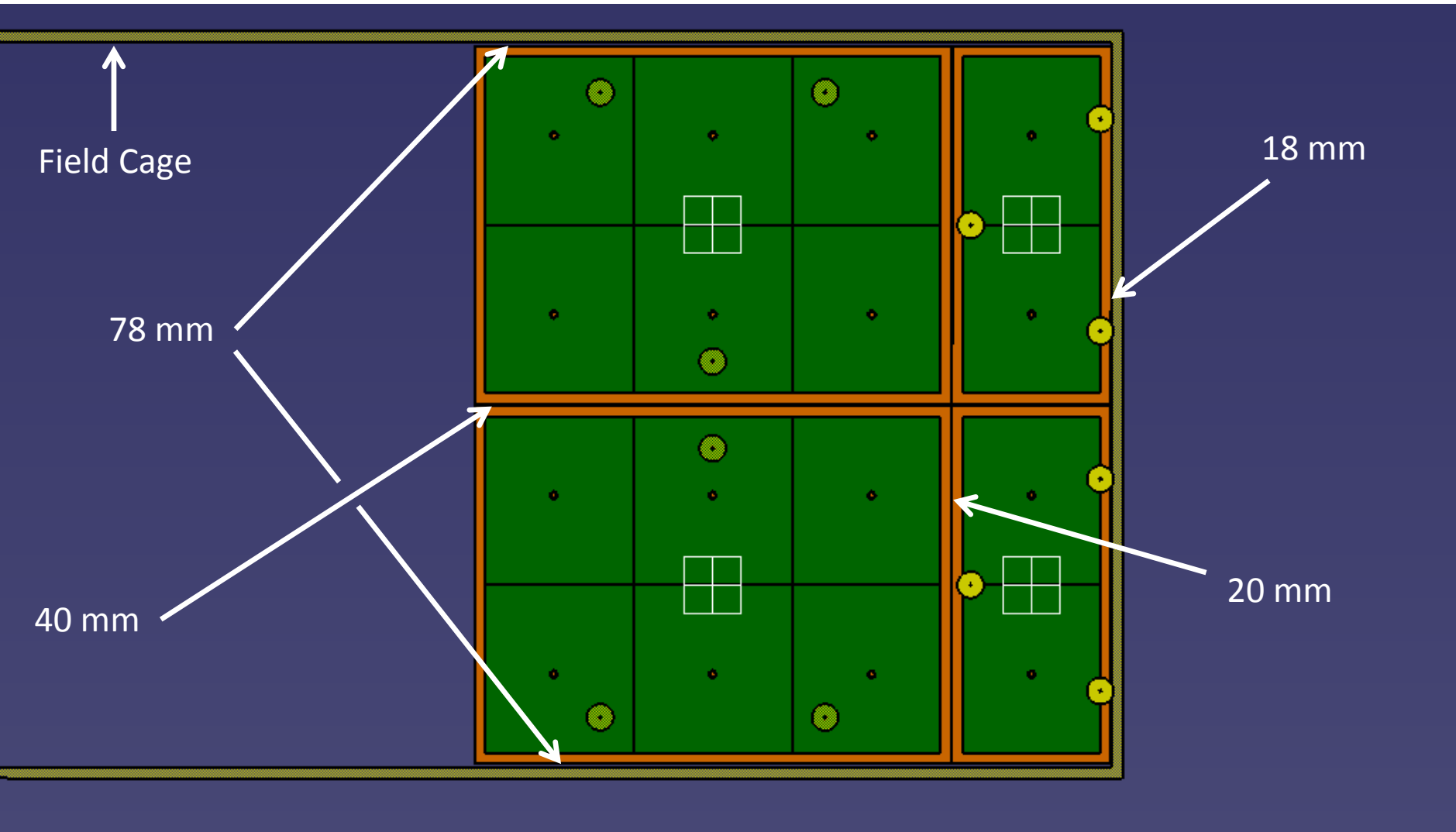

Clearance between SuperStructure and Field Cage is small along longitudinal axis

Superstructure: Stainless Steel

CRP: PCB

Scénario C:

WARM

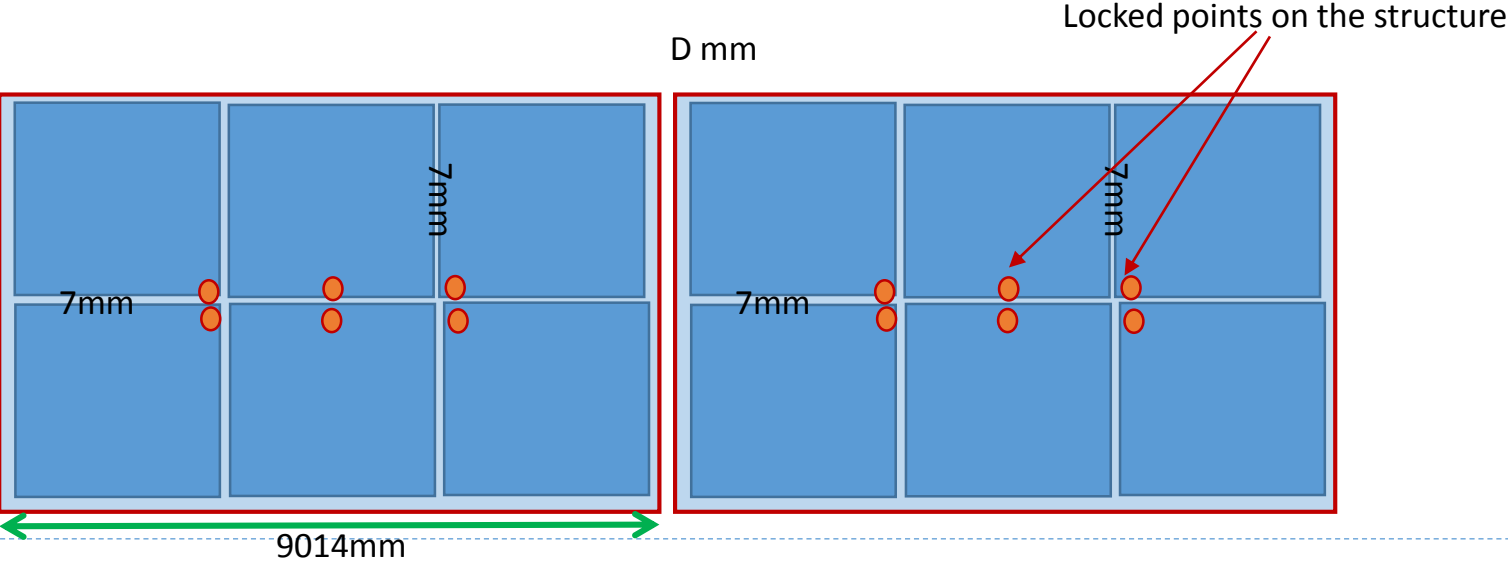

COLD

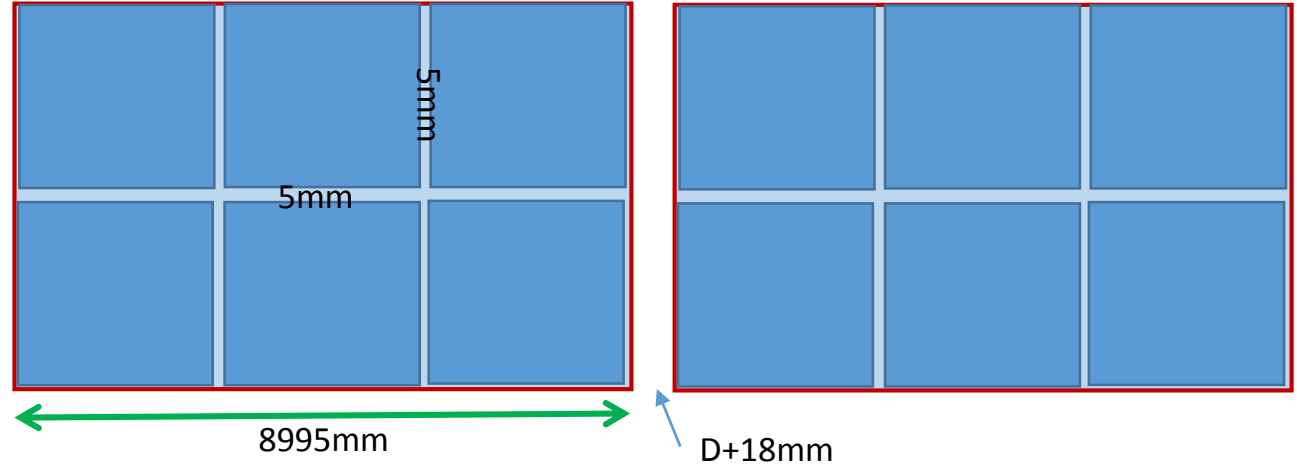

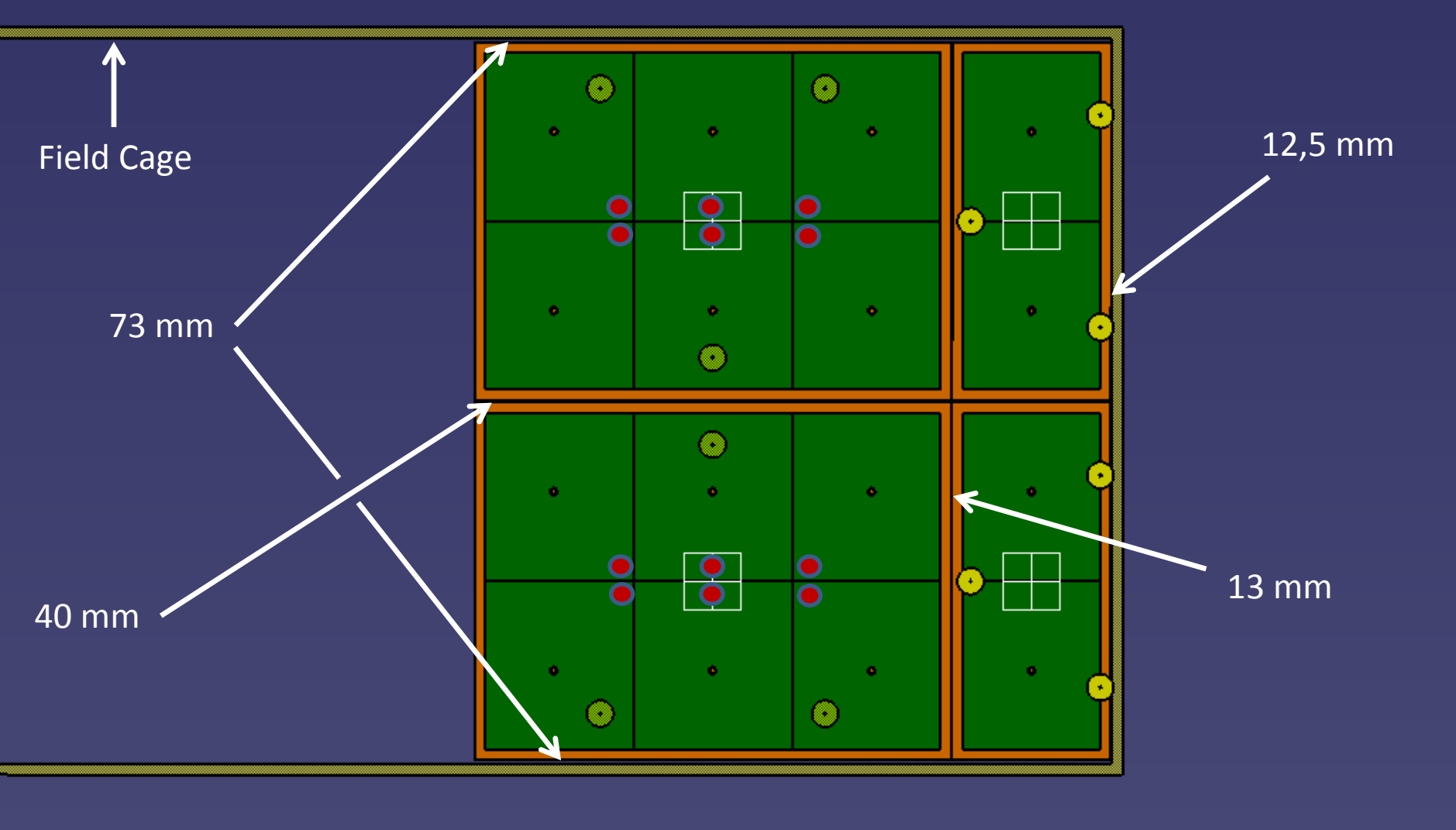

Clearance between SSt and Field Cage is small along longitudinal axis

Production / installation

Manufacturers

Anodes
PCB panels



Machined
parts

Tooling
(transport & installation)

Super-structures

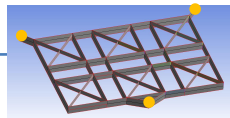

Production
clean room(s)

- Assembly / Glueing of PCB panels 3 x 3,375
- Machined parts assembly
- Anodes planes assembly 1,5 x 1,68
- Electrical cabling
- Packaging in transport boxes **3,5 x 3,5m**

- Manufactured in separable parts (inserable through TCO)
- **Max dimensions : 3000 x 3000?**
- Directly sent to cryostat



Super-structures assembly, on the cryostat ground

A super-structure cannot be transported in one piece

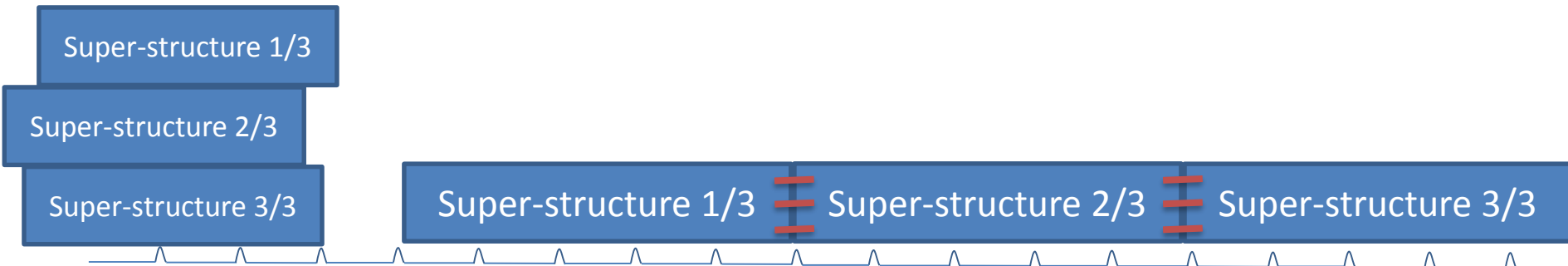

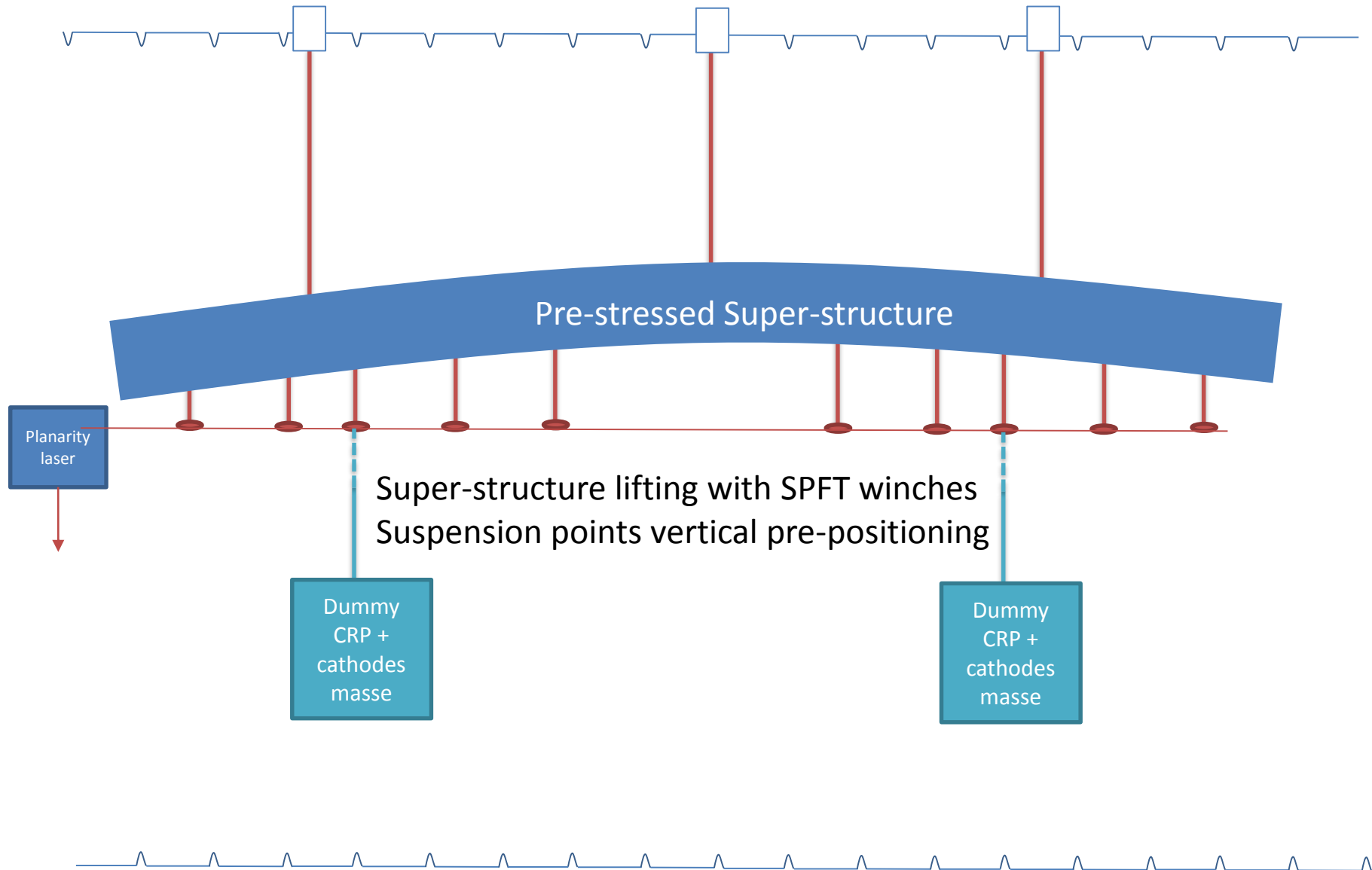

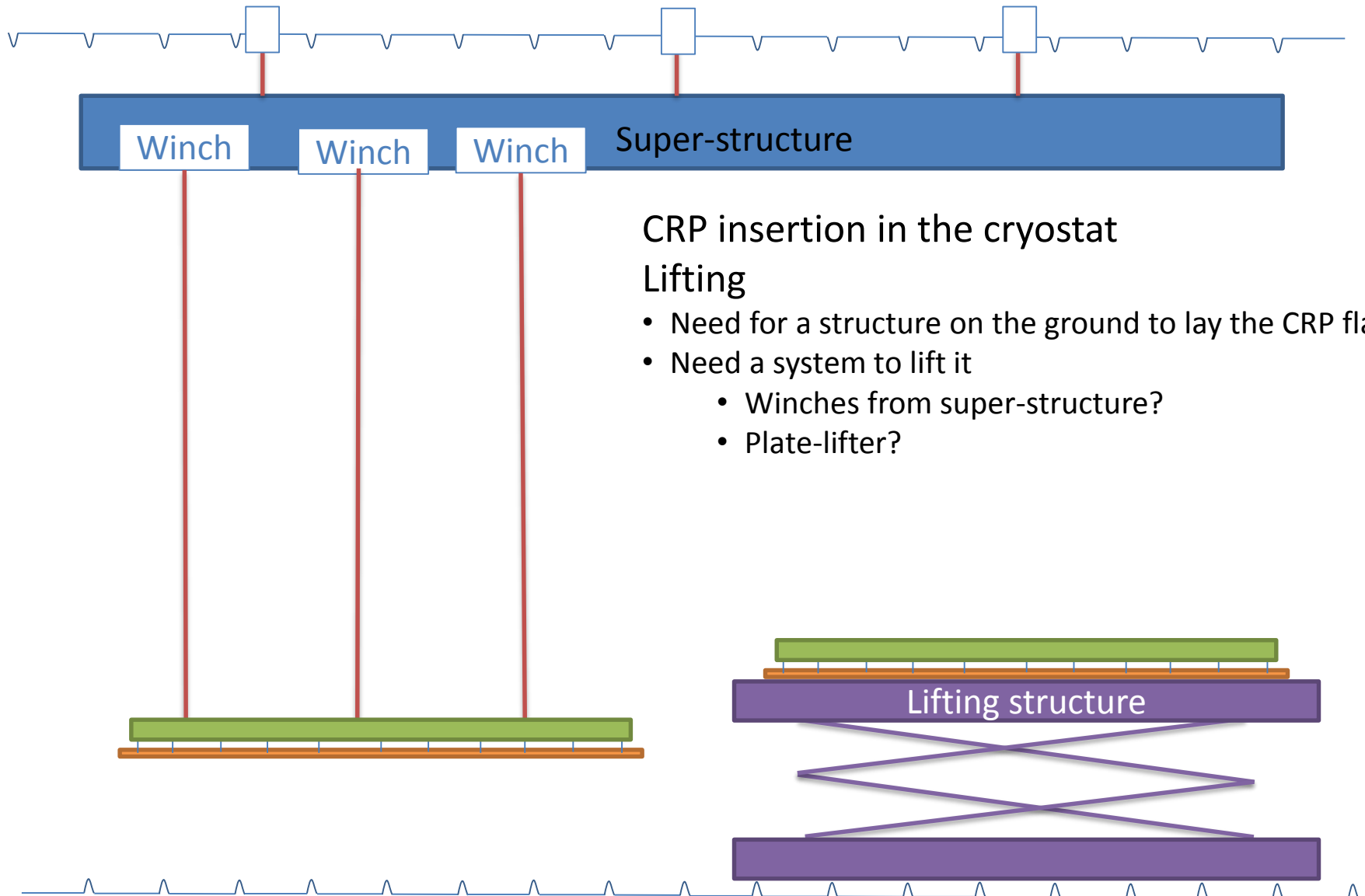

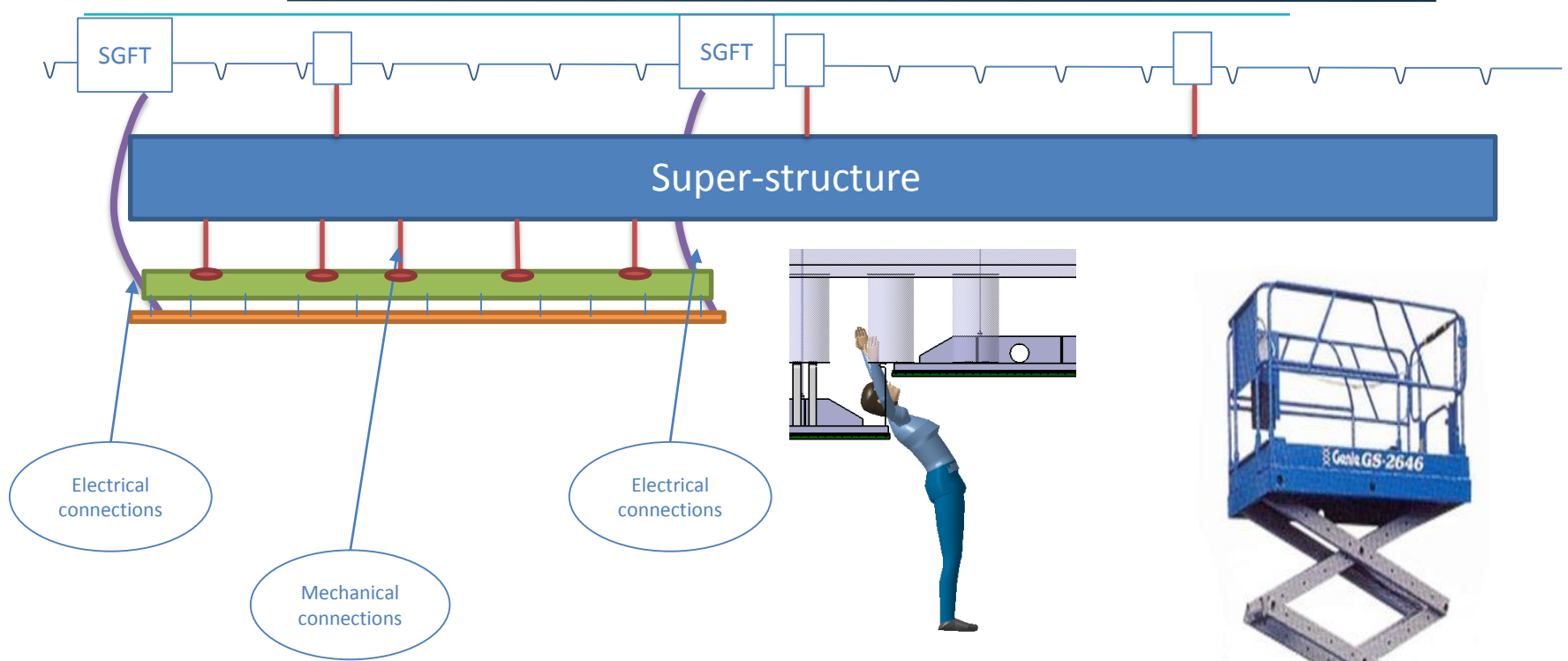

- Need for a person lift to work at height
- In function of the chimney position, need to step the planes under the super-structure to do the connections

Top chimney topology: connexion at each CRP corner

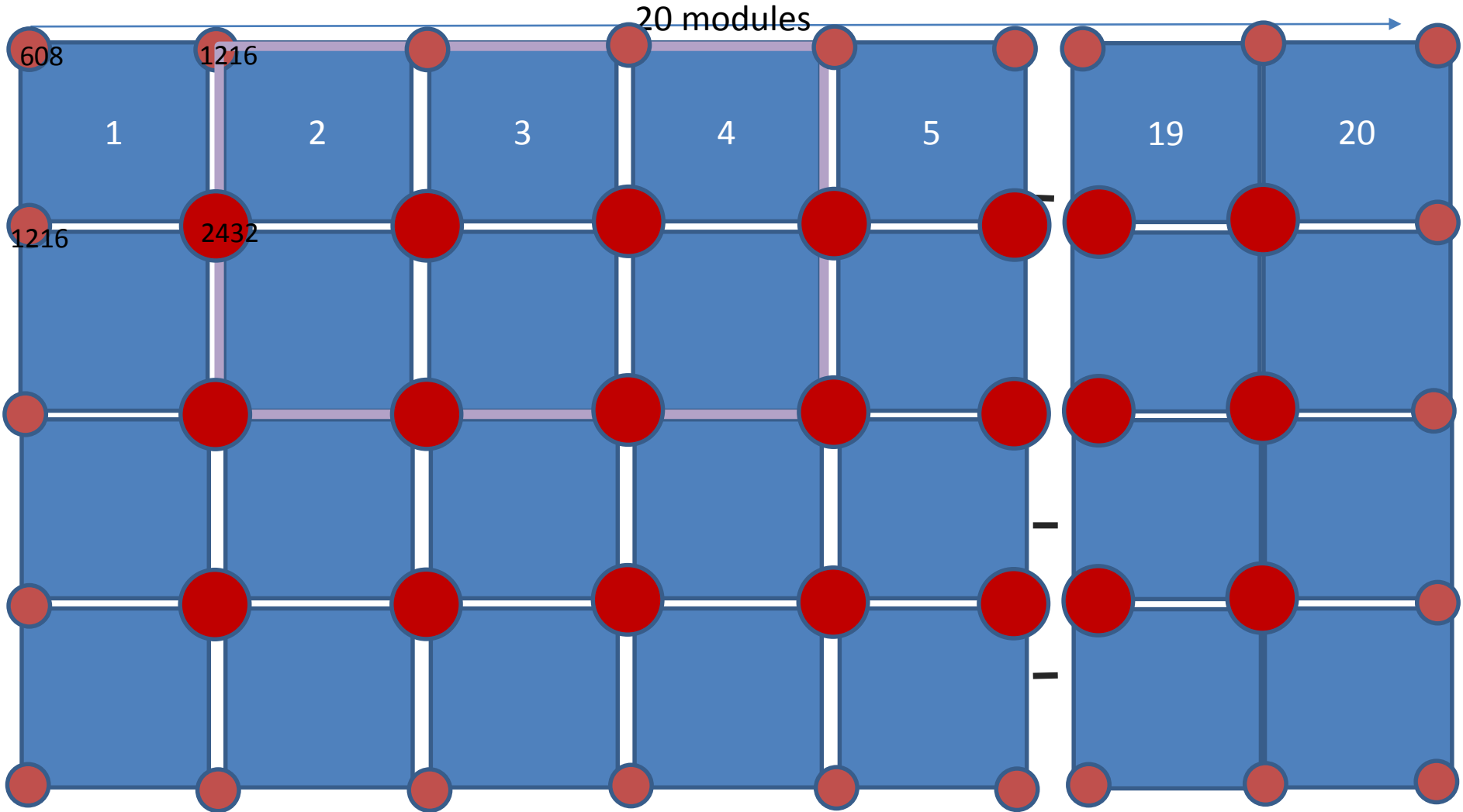

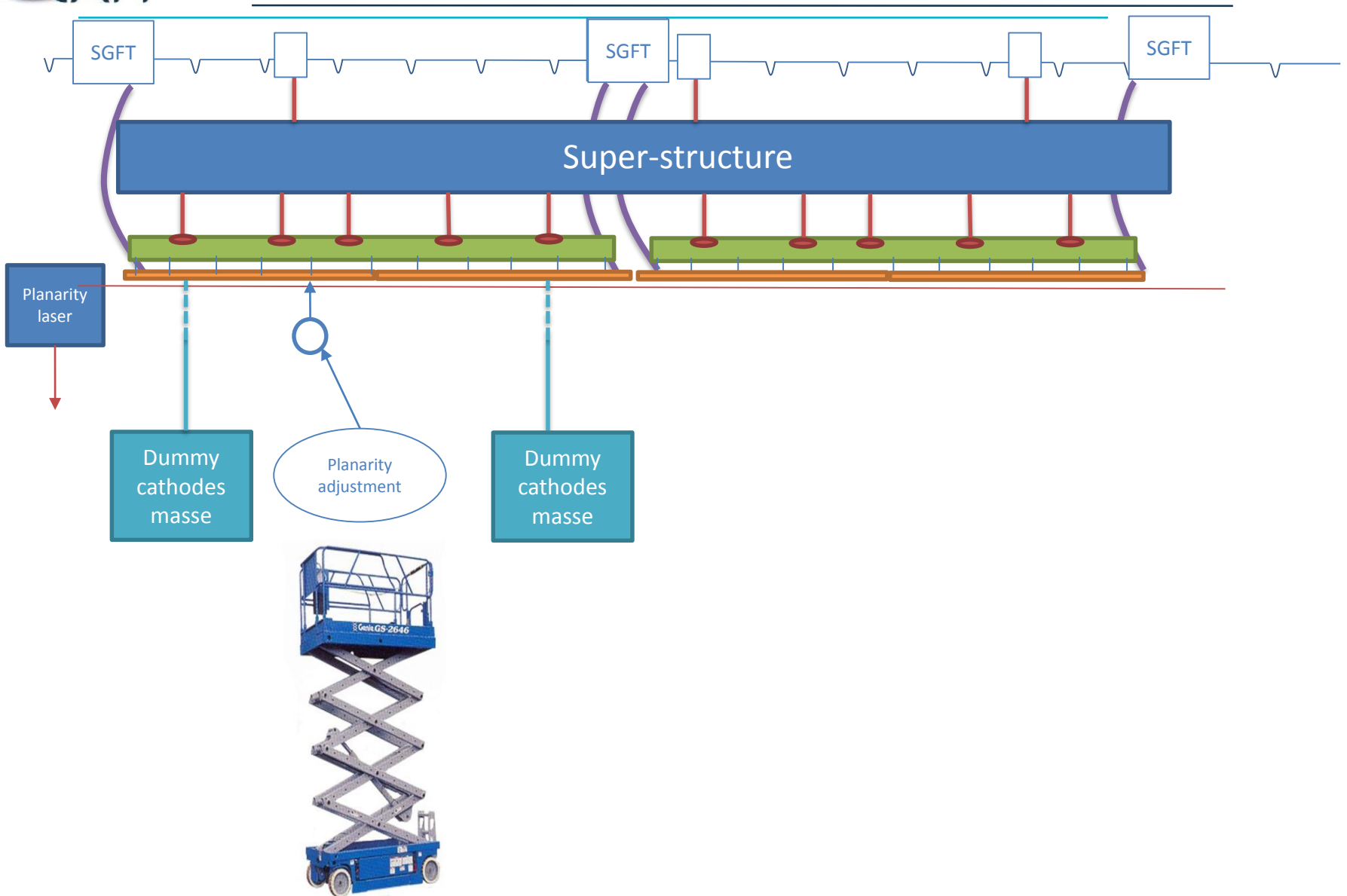

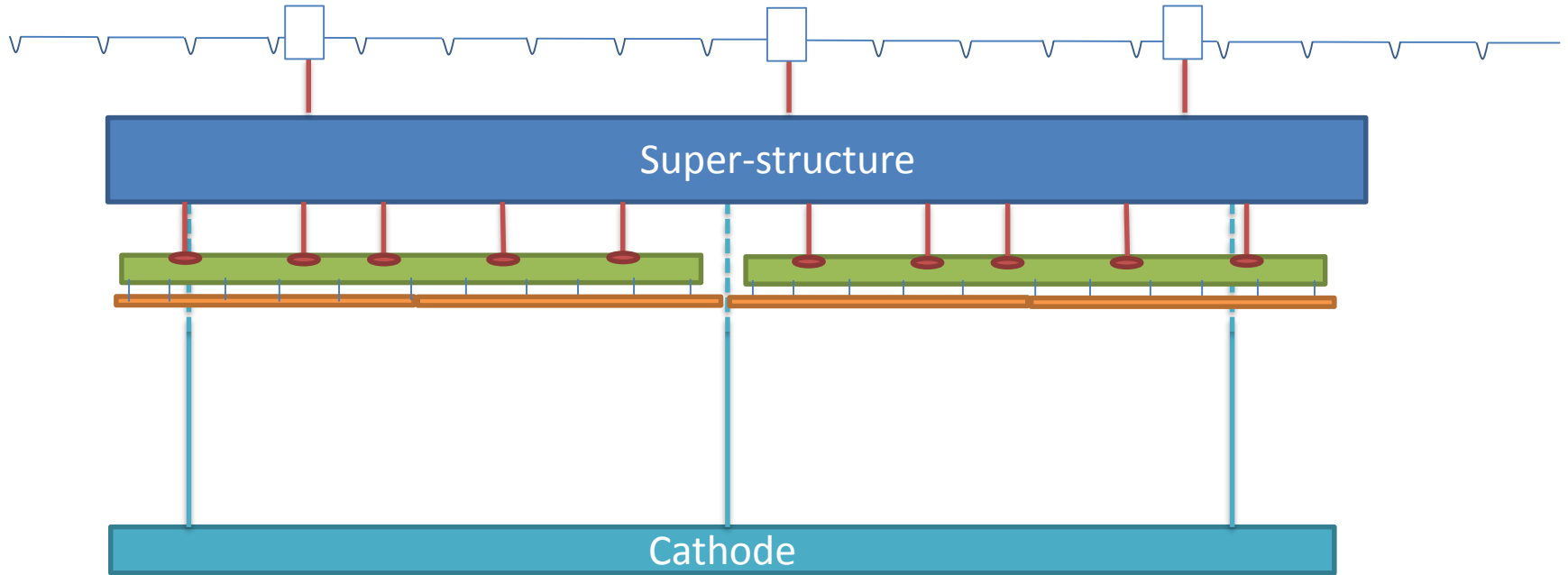

Cathode lifting and suspension

- Winches?
- Plate lift?

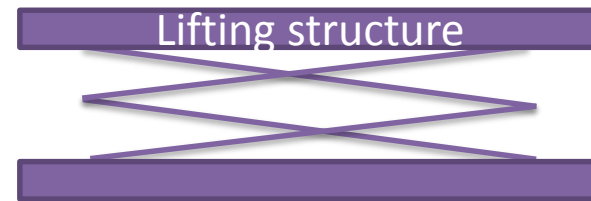

Installation and pre-adjusting of support feet

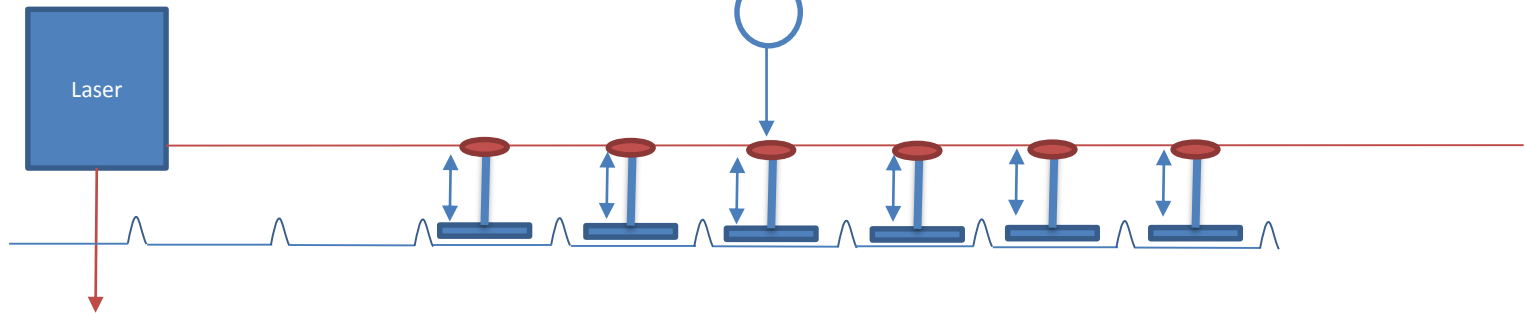
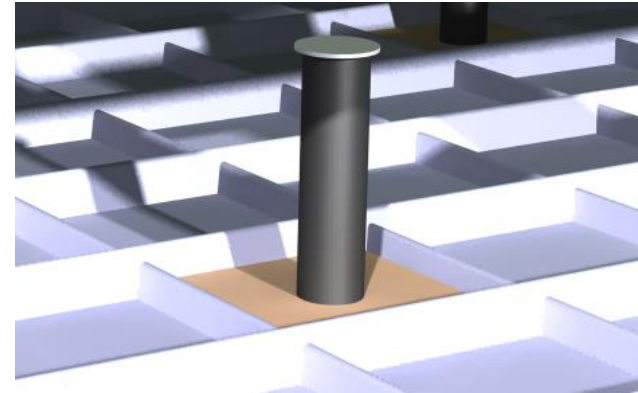

- Installation of CRPs (3000 x 3375mm each)
- Mechanical and electrical connections
- Planarity fine tuning
 - Need to access above the planes

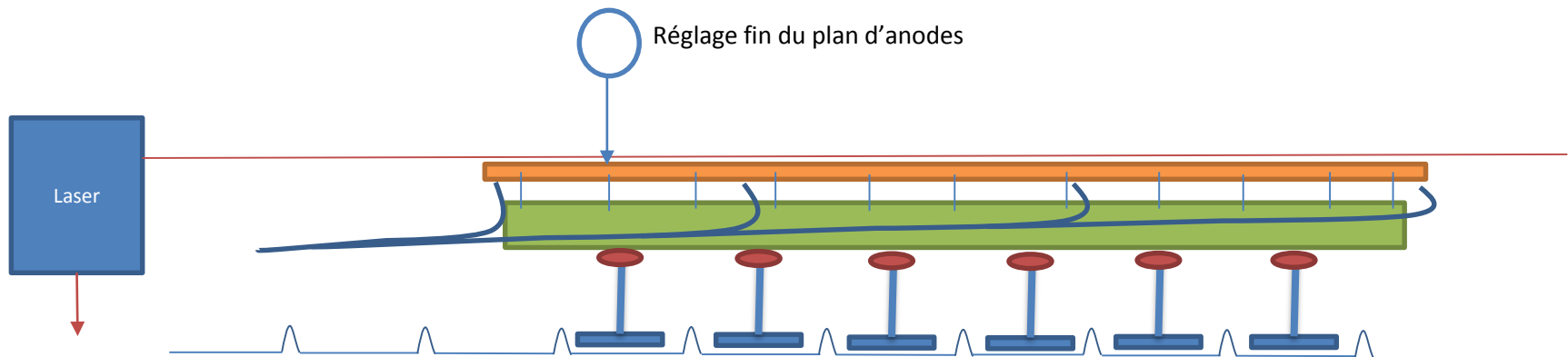

Spare slides

Alternative solution : less supporting screws (33 instead of 36)

-> 1,5m x 1,68m anode plane

- Max displacement, outside part : 0,3 mm
- Max displacement, inside part : **1,3mm**

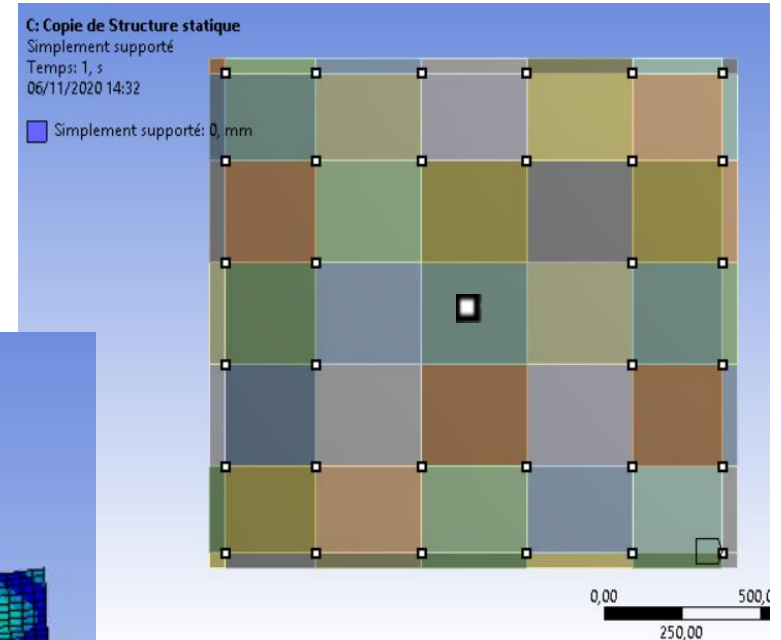
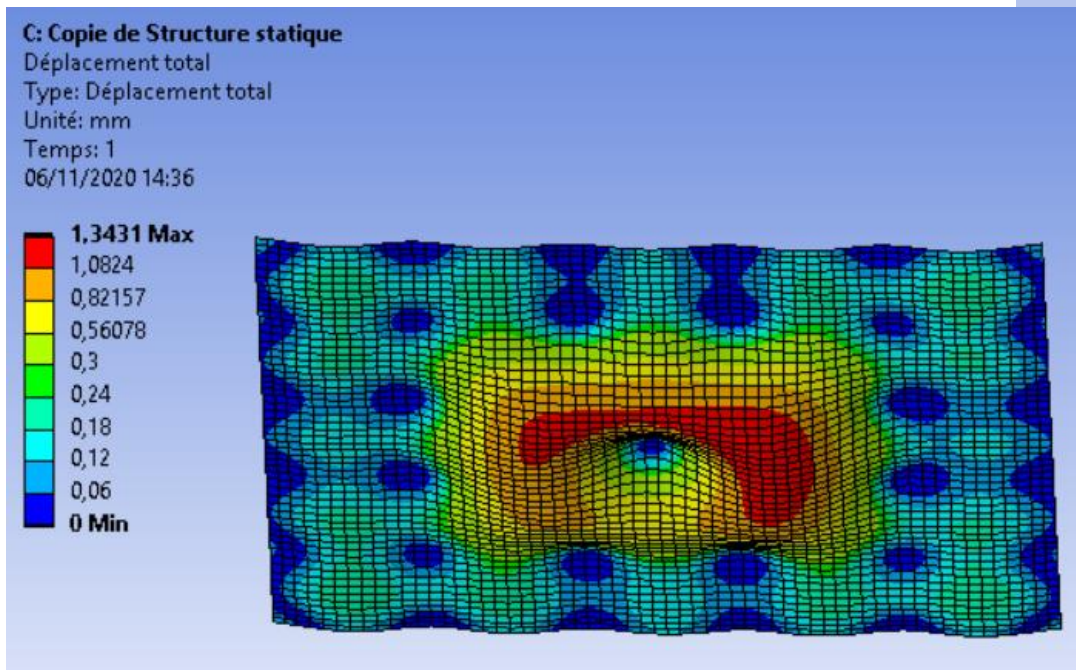

- Few less screws, much higher displacements
- Not worth the change
- Material properties are very influential

- Dimensions : 1500 x 1680 (=3x0,56) x 3,2 mm
- PCB initial density : 1850 kg/m³
- PCB corrected density for anode simulation : 1424,32 kg/m³
- Corrected Young Modulus : **3390 MPa** (26400 for initial material)
- Anode Mass for a 3000 x 3375 mm plane : **46 kg**

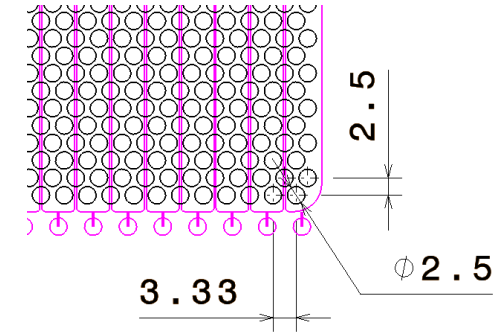

- **To be validated with real tests**
- First contact with CCI EUROLAME (PCB supplier)
 - Cedric Launay
 - Max width : 1225 mm
 - Max length : to be defined
 - Coppered PCB
 - Already in contact with CERN?

Masse volumique PCB plein	1850 kg/m ³
Longueur	1680 mm
Largeur	1500 mm
Epaisseur	3,2 mm
Diamètre des trous	2,5 mm
Espacement en largeur	3,333333 mm
Espacement en longueur	2 mm
Volume d'une plaque pleine	0,008064 m ³
Masse d'une plaque pleine	14,92 kg
Nombre de trous	378000,0378 trous
Volume de trous	0,001855503 m ³
Masse de trous	3,43 kg
Masse d'une anode 15x1,68	11,49 kg
Masse d'un plan d'anode de 3x3,375	45,94 kg
Densité corrigée	1424,32 kg/m ³

$$\alpha_{anode} = 8.10^{-6} K^{-1}$$

$$\alpha_{invar} = 1,8.10^{-6} K^{-1} \text{ (12.5\% of PCB)}$$

$$\alpha_{Stainless\ steel} = 13.2.10^{-6} K^{-1}$$

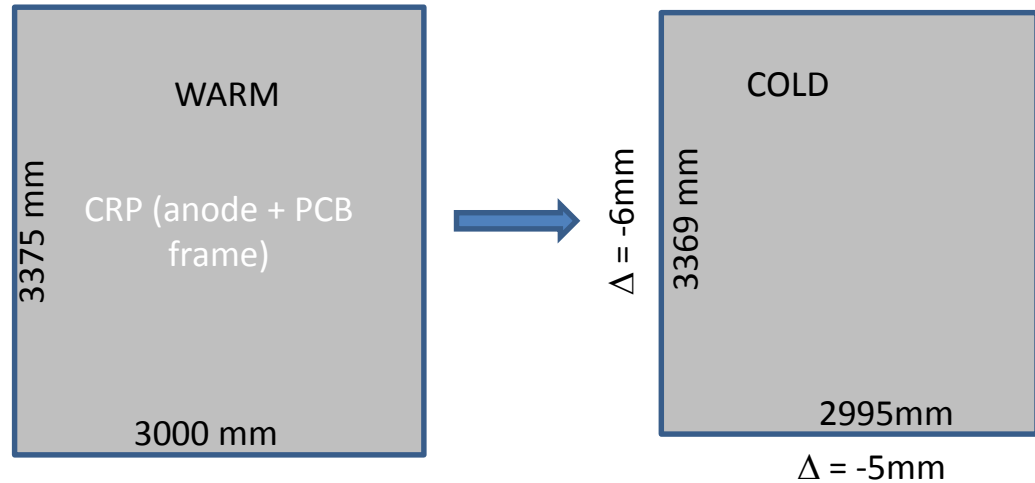

2 suspended point on INVVAR structure separated by
 3000 mm at warm => 2993mm at cold => -0.7mm between 2 CRPs
 3375 mm at warm => 3366 mm at cold =>