

16th (Virtual) "Trento" Workshop on Advanced Silicon Radiation Detectors.  
16-18 February 2021 FBK,

# Femtosecond studies of single event effects in thin LGADs at ELI Beamline

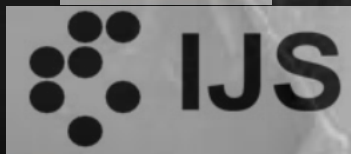
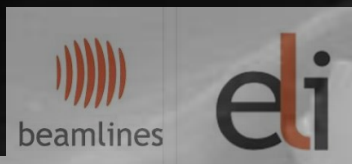

Institute of Physics  
of the Czech  
Academy of Sciences

Gordana Lastovicka-Medin  
University of Montenegro

Gregor Kramberger  
Jozef Stefan Institute

Mateusz Rebarz, Jakob Andreasson, Kamil Kropielniczki  
ELI Beamlines

Jiří Kroll, Michal Tomášek, Marcela Mikestikova, Tomáš Laštovička  
Institute of Physics, Academy of Sciences, CZ

Valentina Sola Nicolò Cartiglia  
INFN Torino



mag	frame	spot	HV	det	mode	WD	HFW
3 830 x	15.8 s	3.0	2.00 kV	ETD	SE	27.8147 mm	108 μm

# LGADs breaking down at high $V_{\text{bias}}$

- ❑ Destructive breakdowns appear mostly in the test beams (TB) – much less in the laboratory setups (Sr90, probe stations)
- ❑ HPK-P2 sensors seem to be robust in the laboratory conditions.
- ❑ Destructive breakdowns (fatalities) appear at bias voltages that are significantly (50 -100V) lower than those in the lab.
- ❑ They appear suddenly without a clear warning (increase of leakage current, instability in leakage current, changes in gain; this also seen in ELI tests)
- ❑ There are indications that fatalities are beam related and not linked to the environmental conditions
- ❑ We don't know the reasons for these breakdown:
  - ❑ Is it the high electric field in highly irradiated sensors that is the problem?
  - ❑ Is it the gain of the devices that plays a role?
  - ❑ Is it the irradiations that are the reason, or they merely facilitate the conditions where high bias voltages can be applied?
- ❑ We intend to address all of the above possible reasons (use of irradiated LGADs, PINs, gamma irradiated PINs of the same design).
- ❑ The main difference between lab (Sr-90 with  $E_{\text{max}}=2.3$  MeV) and TB (up to several tens MeV deposits – CMS paper) is the energy of the particles:

**Can huge amount of charge in a single collision cause a conditions that lead to a destructive breakdown?**

# A possible explanation

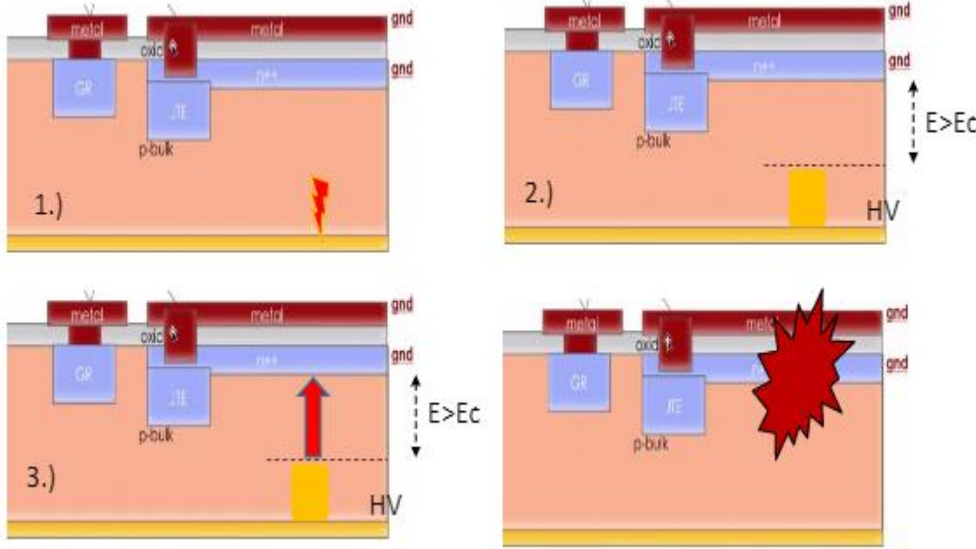

1.) larger deposition of the charge (fragments producing deposition in few  $\mu\text{m}$  as large as 1000 mip- CMS tracker paper ) in few  $\mu\text{m}$  (not possible with lab sources)

2.) larger density of carriers leading to collapse of the field (screening prevents the carriers from being swept away)

3.) once the field collapses the HV is brought closer to the pad which leads to very high field strength leading to avalanche breakdown and full discharge of sensors and bias capacitor

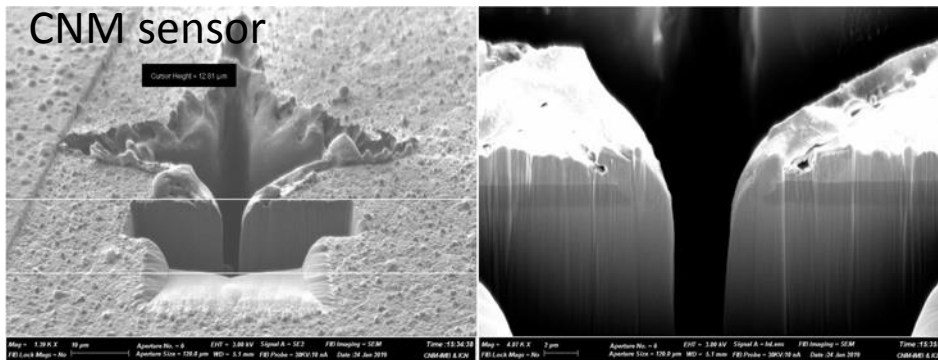

“courtesy of CNM (ATLAS TB sensor)”

Thanks to CNM for providing the photos of such fatality.

If the speed of deposition is similar to Mip then the laser test with extremely high energy per pulse in 50 fs should lead to fatalities

Tests uses 800 nm (27  $\mu\text{m}$  penetration) of 50 fs pulses with pulse of up to a 1 mJ. Pulses are focused to dimensions similar that of mip deposition (1-2  $\mu\text{m}$  cone)

Czech Republic  
Dolní Břežany (on the outskirts of Prague)

Experimental hall E1  
Research program: Bio and Material Applications

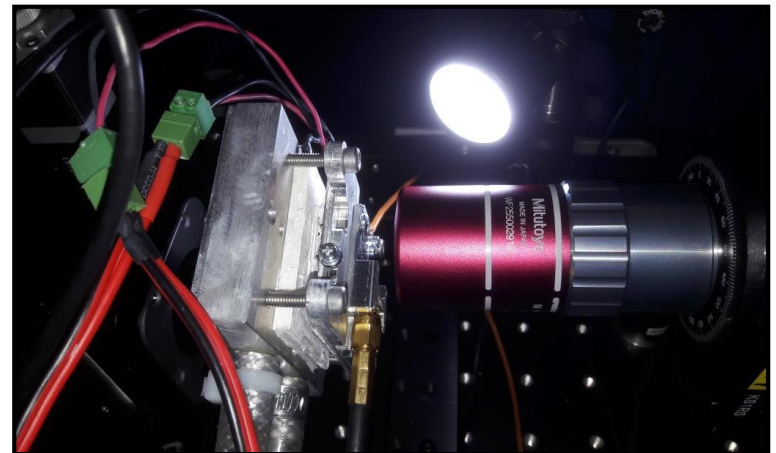
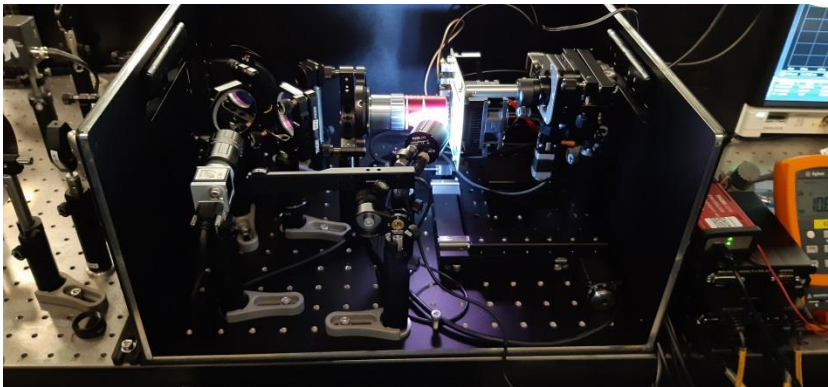

Project supported by: Advanced research using high intensity laser produced photons and particles (ADONIS) Reg. n.: CZ.02.1.01/0.0/0.0/16\_019/0000789

Pad of LGAD visible by imaging system

**Beam focused to the center of the sensor**

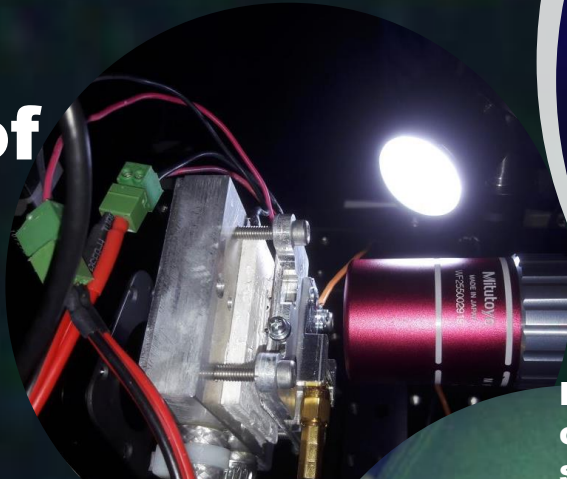
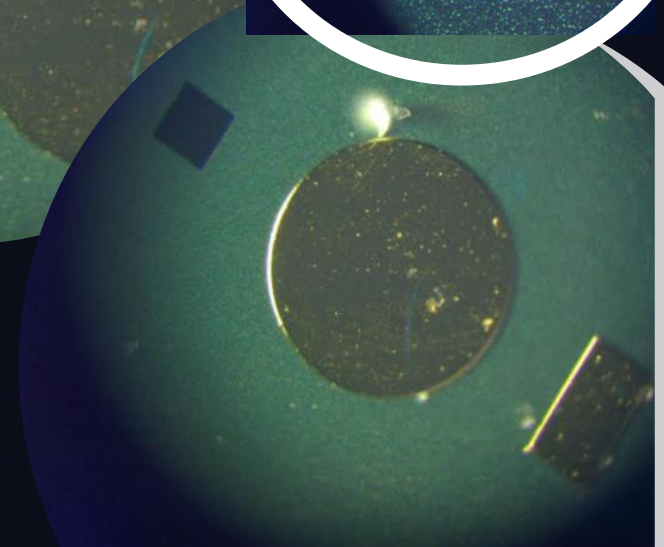
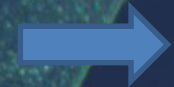
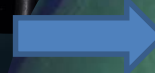
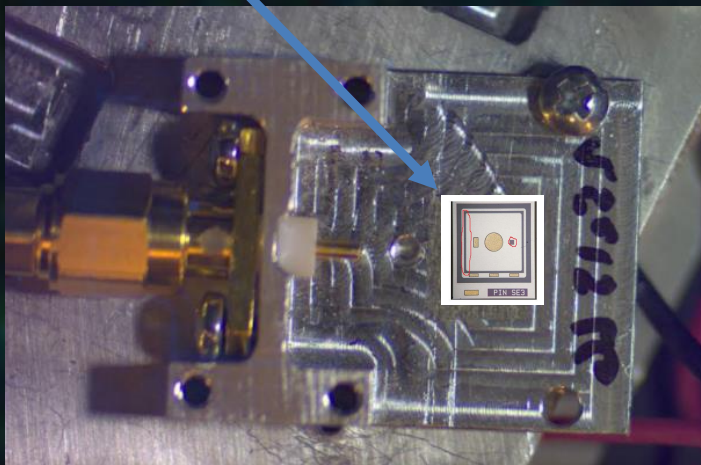
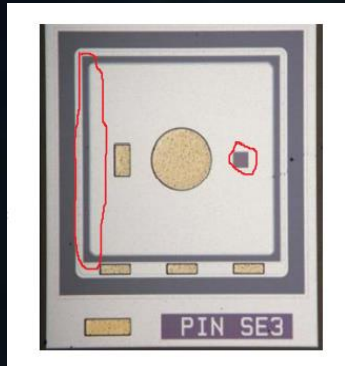

Image corresponds to the specified area (opening window) when 100X objective is used (during experiment)

Pad of LGAD and laser printed in the center of the pad visible by imaging system

Image corresponds to the larger area of the sample if 25X objective is used instead of 100X (not used during experiment but used in pre-alignment of the sample position).



# Samples and readout

- ❑ The samples are from HPK-P2 run, the latest ATLAS/CMS LGAD fabrication (shown in many talk in the workshop)
  - ❑ W36 ( $V_{gl} \sim 51.5$  V,  $V_{bd} \sim 220$  V)
  - ❑ fluences covered are the ones of interest for ATLAS and CMS:  $4e14$ ,  $8e14$ ,  $1.5e15$ ,  $2.5e15$   $cm^{-2}$
- ❑ For each sensor (4 sensor, 4 fluences) the bias was increased up to the maximal expected value (340, 520, 680, 780 V for respective samples) where the IV was measured

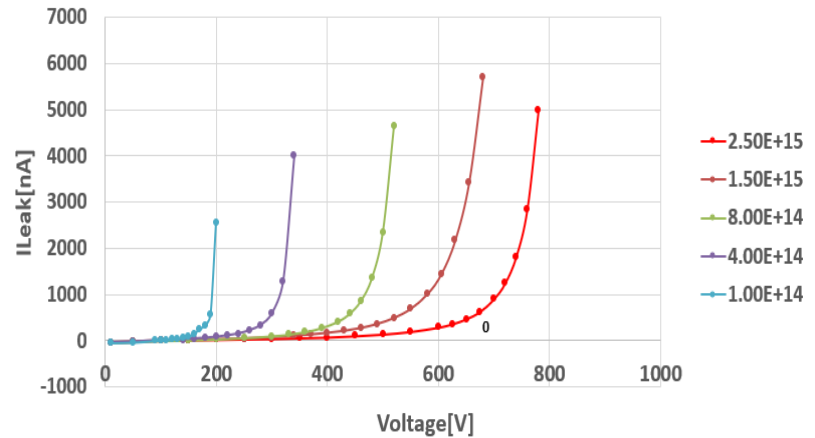
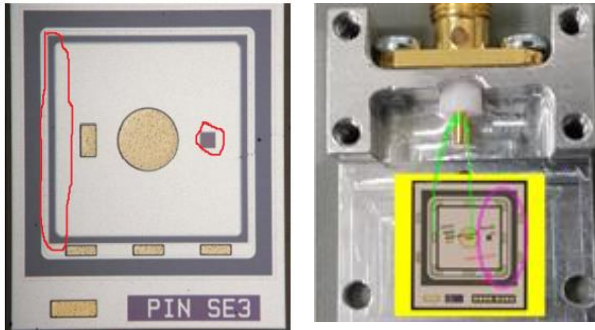

## MORTALITY STUDIES

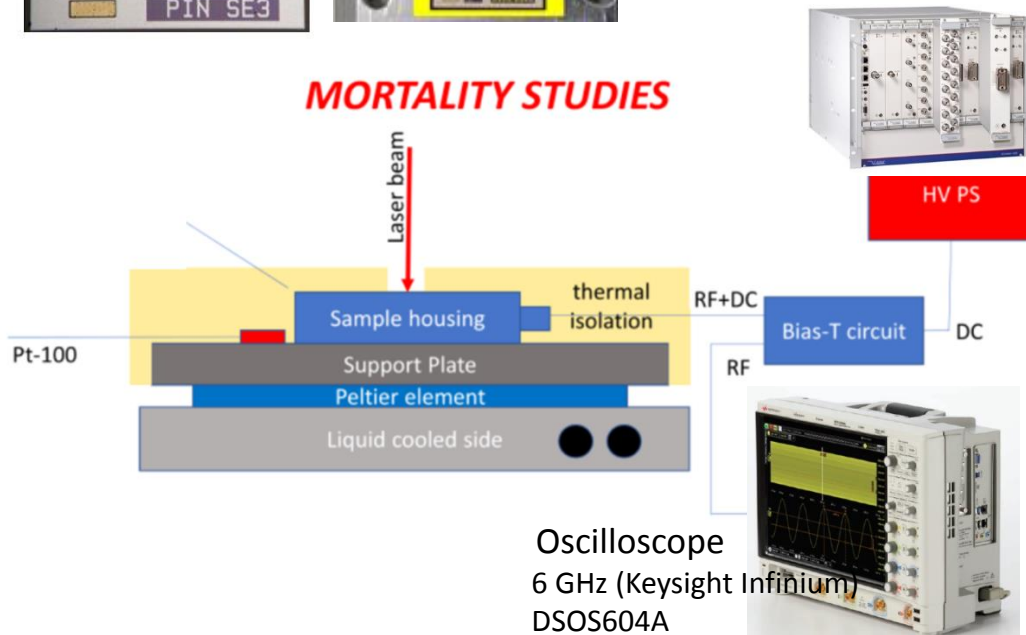

- Closed circuit chiller  $T = -25$  C
- $N_2$  flushed to avoid condensation.
- No active amplifier used—we want large signals.
- Bias-T used to prevent discharge into oscilloscope
- No other bias filtering used
- ✓ HV power supply: EB1200305040000200 (Iseg)

# TCT signals

**LGAD WF36,  $4e14 n_{eq}/cm^2$**   
 **$P_{laser}=10 nW$**

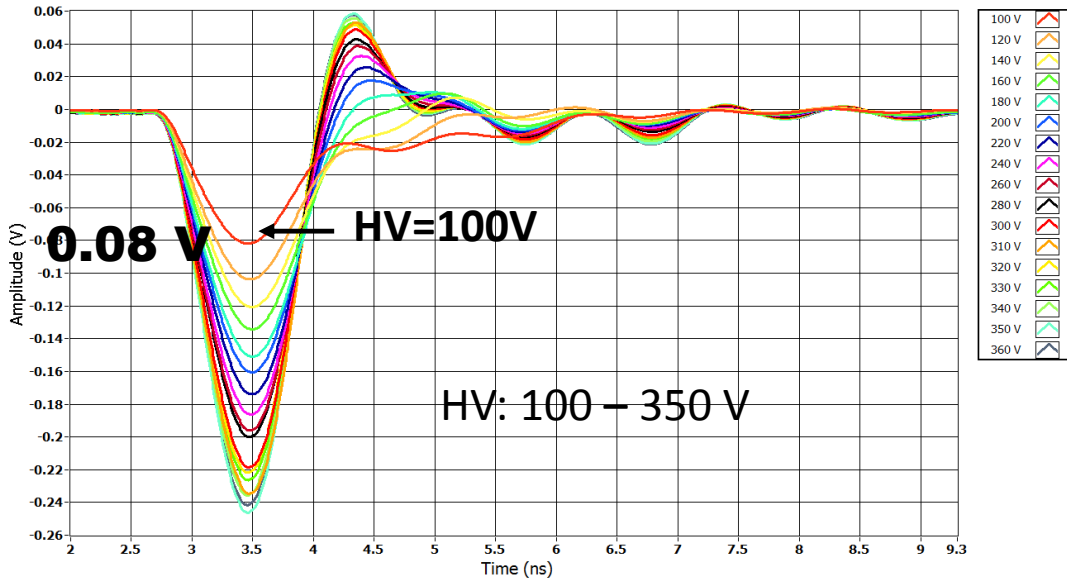

## Generated Ne-h

1. Calculation from signal recorded on the diode at 10 nW

$$N_{e-h} = \frac{1}{e_0 R} \int_0^{5 ns} V_{sig}(t) dt$$

$$N_{e-h} \sim \frac{1}{1.6e-19 As \cdot 50\Omega} 0.08 V \cdot 1ns \sim 10^7 e-h$$

2. Calculation from the beam parameters at 10 nW

$$E_{pulse} = \frac{P}{\nu}$$

$$N_{e-h} = \frac{E_{pulse}}{e_0} \cdot Q_E \cdot R_{e-h}$$

$$N_{e-h} = \frac{10nW}{1000s} \cdot 0.5 \cdot 1 \cdot \frac{R_{e-h}}{1.6e-19 As} = R_{e-h} \cdot 6.2 \cdot 10^7 e-h$$

3. A factor of 6 difference implies to large recombination possible. Recombination rate R is very much affected by the irradiation on. In order of both calculations to agree R has to be 1/6

4. The equivalent lost charge in the silicon to produce the same signal:

$$\Delta E = N_{e-h} 3.62eV = \sim 30 MeV$$

This is of the same order as seen in CMS paper(

# Signals at all fluences

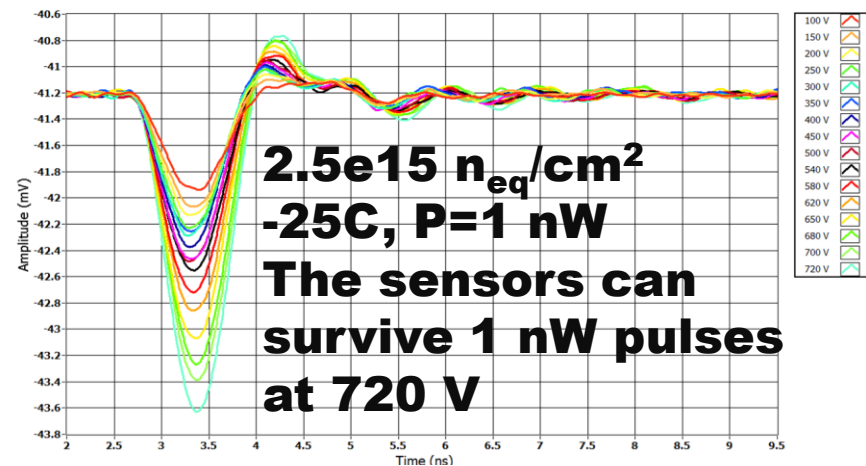
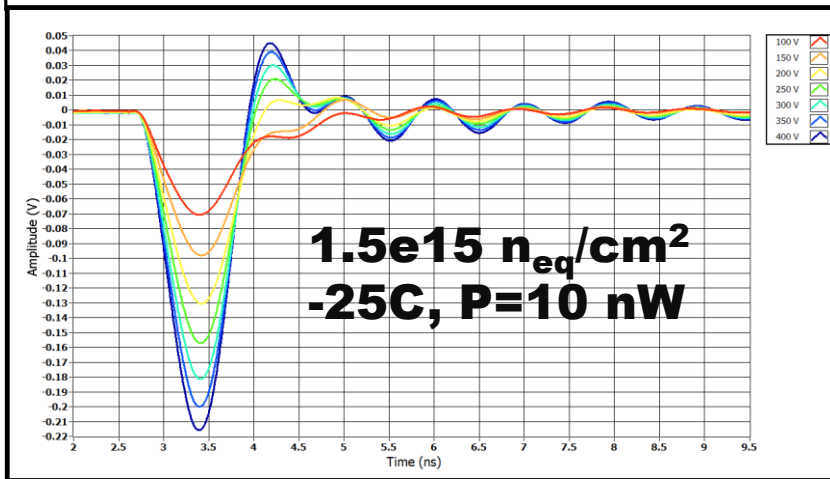
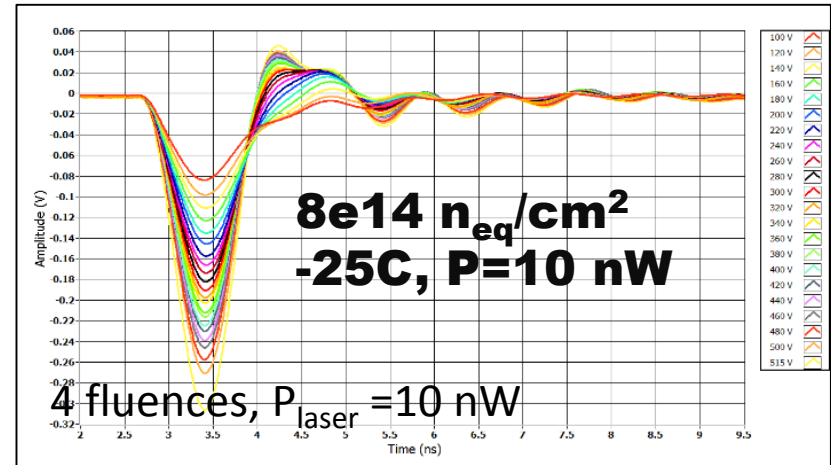
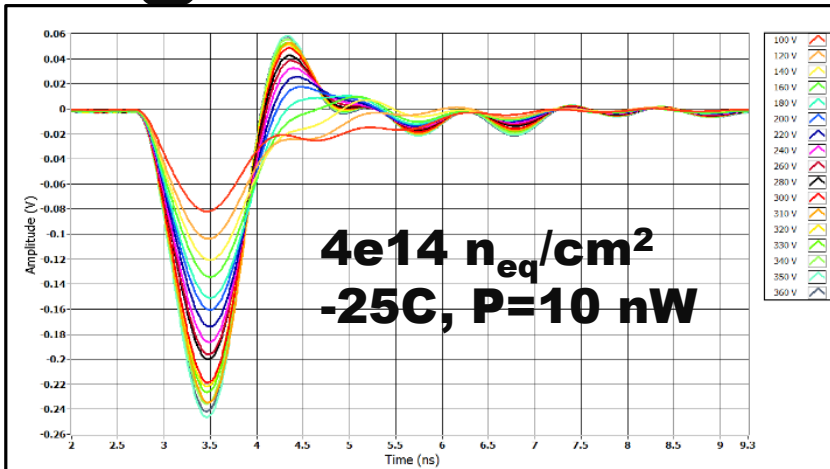

- ✓ At  $P_{laser} = 10 nW$  (that corresponds to pulse energy of 10pJ – repletion of the laser 1000 Hz) the same integrated charge is observed for all 4 fluences at HV=100 V where no gain is present due to high radiation;
- ✓ No visible plasma effects – rise time comparable also at low and high bias. Risetime comparable with RC constant.
- ✓ Recombination of e-h seems only moderately fluence dependant



# Exposure to extreme energies

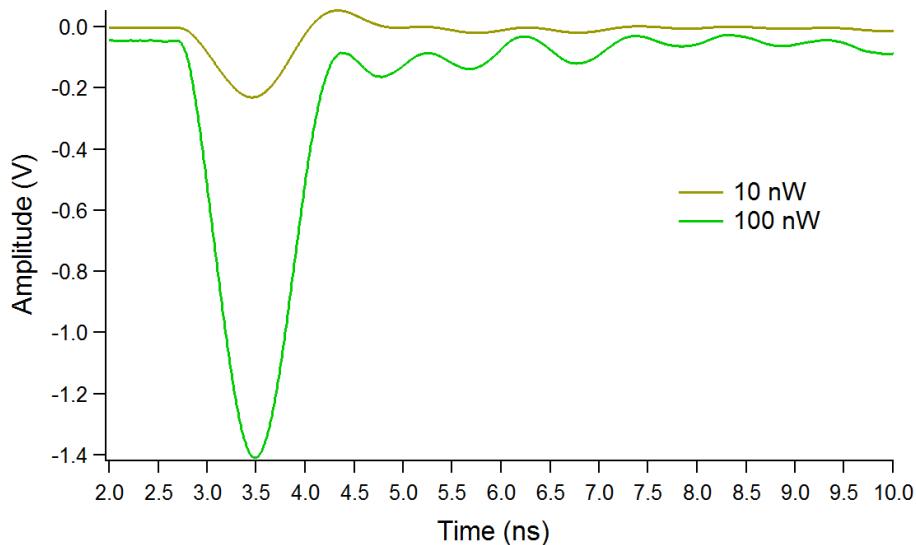
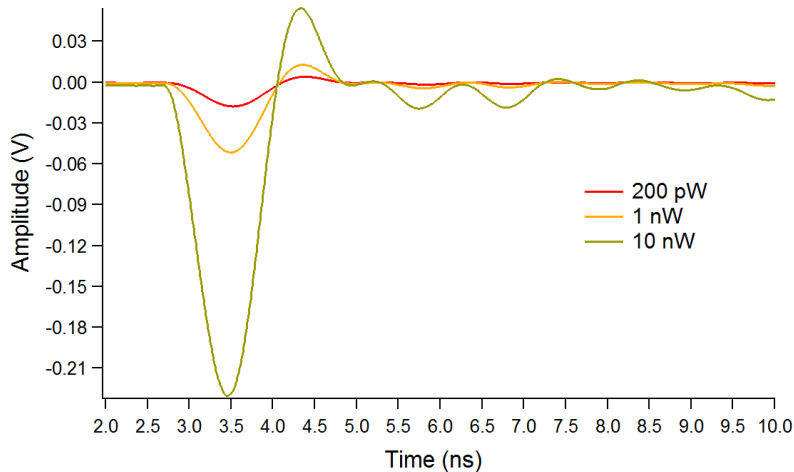

- ✓ WF36,
- ✓  $4e14 \text{ n}_{\text{eq}}/\text{cm}^2$
- ✓ HV was set to maximal HV (HV=320 V)
- ✓ Laser power was increased until LGAD died
- ✓ Changes in the signal waveform were observed
- ✓ Laser power  $L_{\text{power}} = 100 \mu\text{W}$  was critical point which completely destroyed the sensor
- ✓  $P_{\text{laser}} = 100 \mu\text{W}$  is extremely large power; LGAD will never worked under such extreme power.

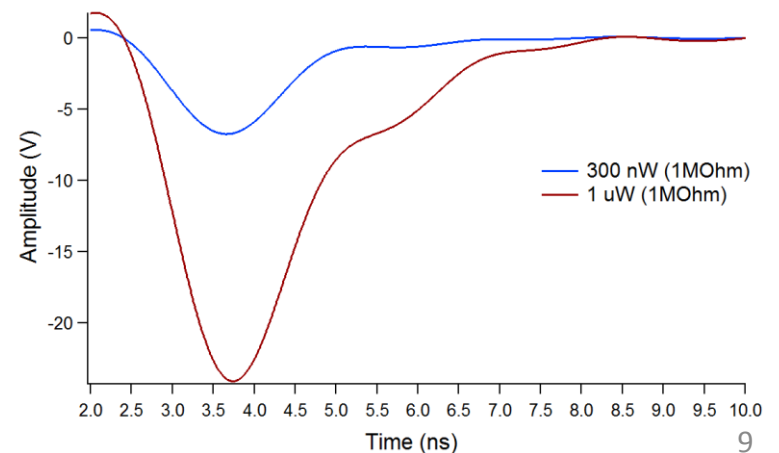

# MEASUREMENTS (I)

## Fatality signatures

### LGAD

- ✓ **W36 LGAD,  $4e14 \text{ cm}^{-2}$  :**
- ✓ The HV was set to 340 V (breakdown bias measured by Sr-90 in lab)
- ✓ After reaching the laser power of  **$100 \mu\text{W}$**  at bias of **340 V** the sample partially broke down.

Missing  
microscope  
image



# MEASUREMENTS (I)

## Fatality signatures

- ✓ **W36 LGAD,  $8e14 \text{ cm}^{-2}$ :**
- ✓ The HV was set to 500 V (breakdown bias measured by Sr-90 in lab)
- ✓ After reaching the laser power of  **$10 \mu\text{W}$**  at  **$500 \text{ V}$**  the sample broke down.
- ✓ Damage can happen anywhere as demonstrated in the image below; laser was focused to the center of sensor opening,  $d=1.7 \mu\text{m}$ .

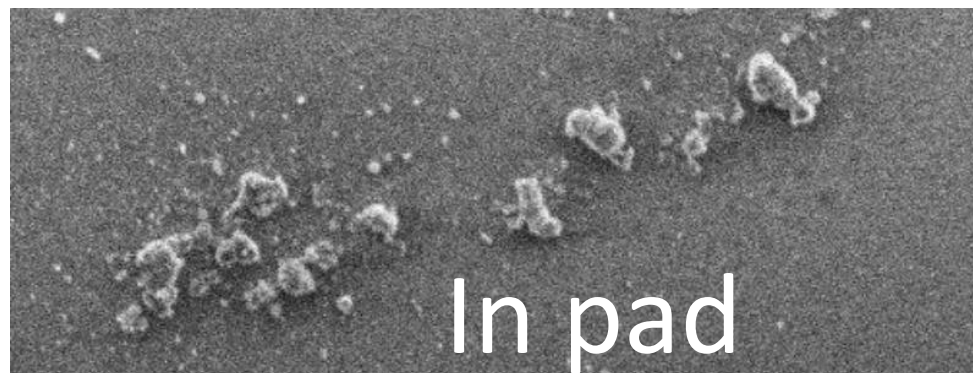
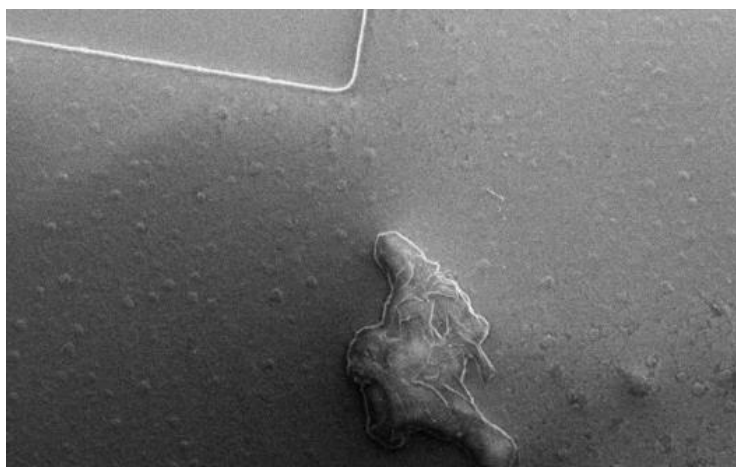
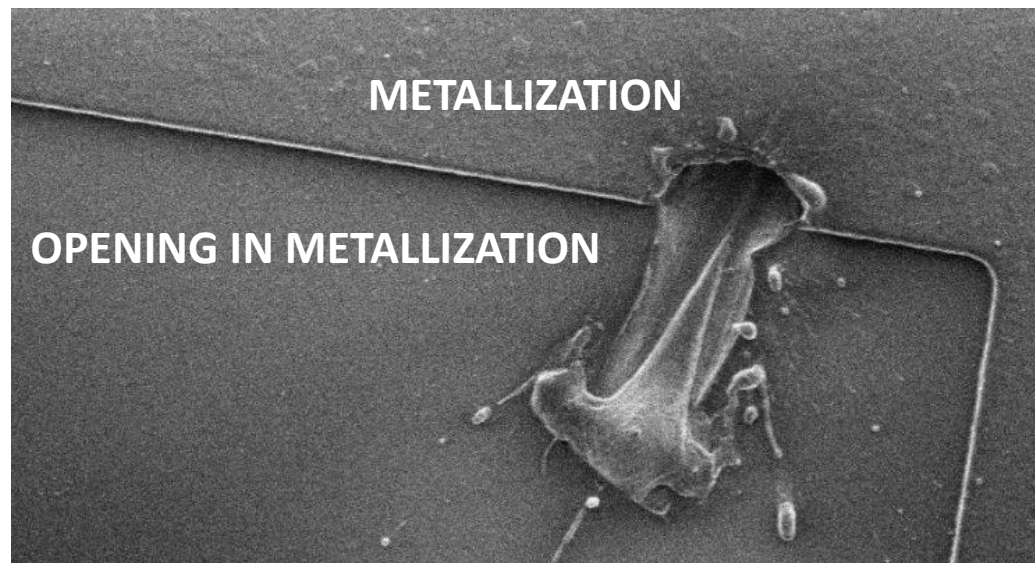

# MEASUREMENTS (I)

## Fatality signatures

W36 LGAD  $1.5e15 \text{ cm}^{-2}$  (I exp)

- ✓ The HV was set to 680 V
- ✓ After 3 nW illumination at 680 V the sample broke down (~10 MeV od deposited energy).

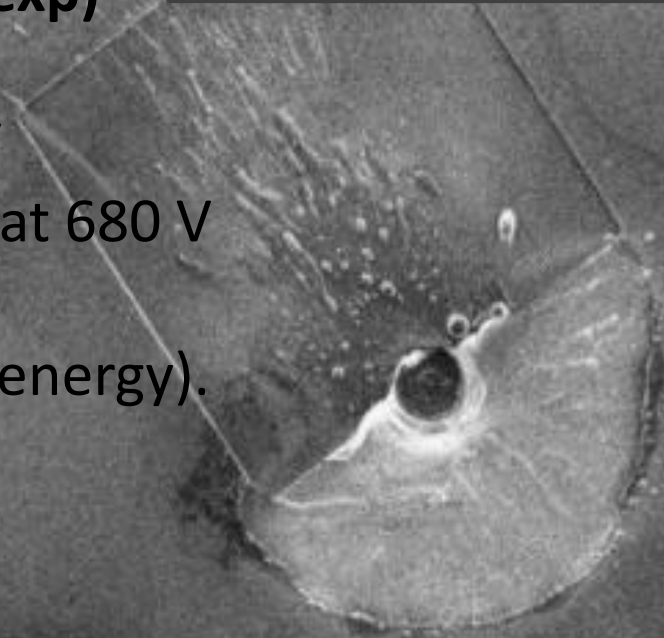

mag □ frame

spot HV

det mode WD

HFV

100 μm

# MEASUREMENTS (I)

## Fatality signatures

### WF36 LGAD

### $1.5e15 \text{ cm}^{-2}$ (II exp)

- ✓ The HV was increased in steps, and survival of sensor was scanned in the way that at each chosen HV bias the fatality/survival was tested by increasing the laser power until LGAD brake down.
- ✓ The sample broke down at 400 V when illuminated by  $6 \mu\text{W}$ .
- ✓ Sample was still operational at lower bias HV=230 V.

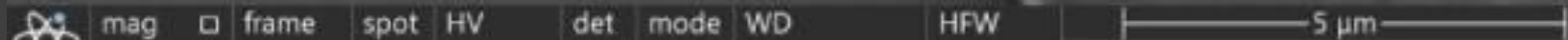
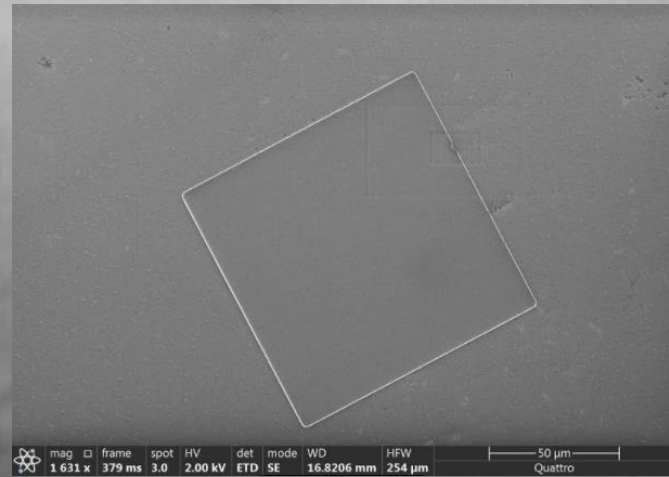

# MEASUREMENTS (I)

## Fatality signatures

**WF36 LGAD  $2.5e15 n_{eq}/cm^2$  (I exp)**

- ✓ The HV was set to 780 V
- ✓ Laser power was increased until sensor brake down.
- ✓ At  $1\mu W$  of laser power the LGAD broke down.

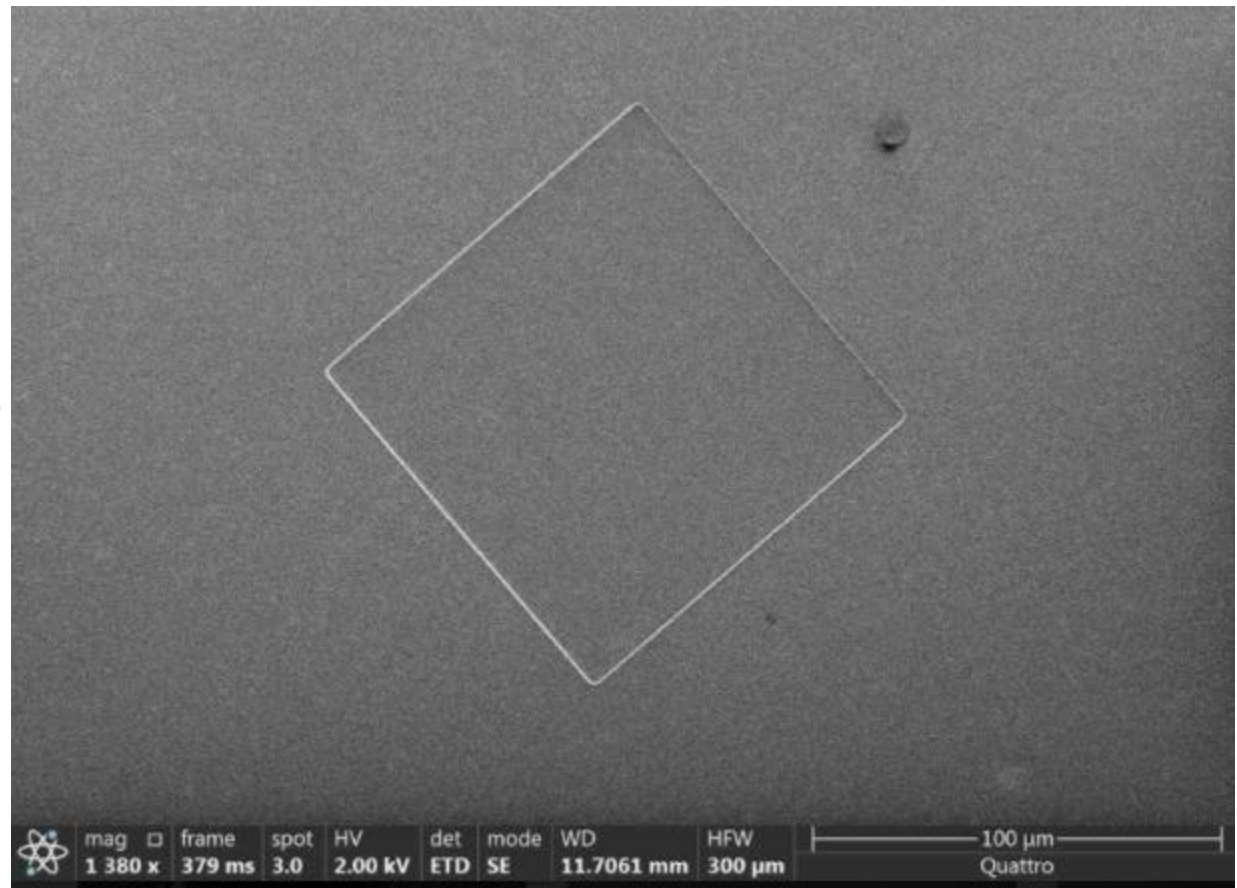

# MEASUREMENTS (I)

## Fatality signatures

**WF36 LGAD (II exp)**  
 **$2.5e15 \text{ cm}^{-2}$**

- ✓ The HV was increased in steps, and survival of sensor at each step (chosen HV) was tested by increase of laser power till sensor brake down.
- ✓ In this case the LGAD broke down at bias of 450 V at 6  $\mu\text{W}$ .
- ✓ Sample was still operational at lower bias HV=230 V

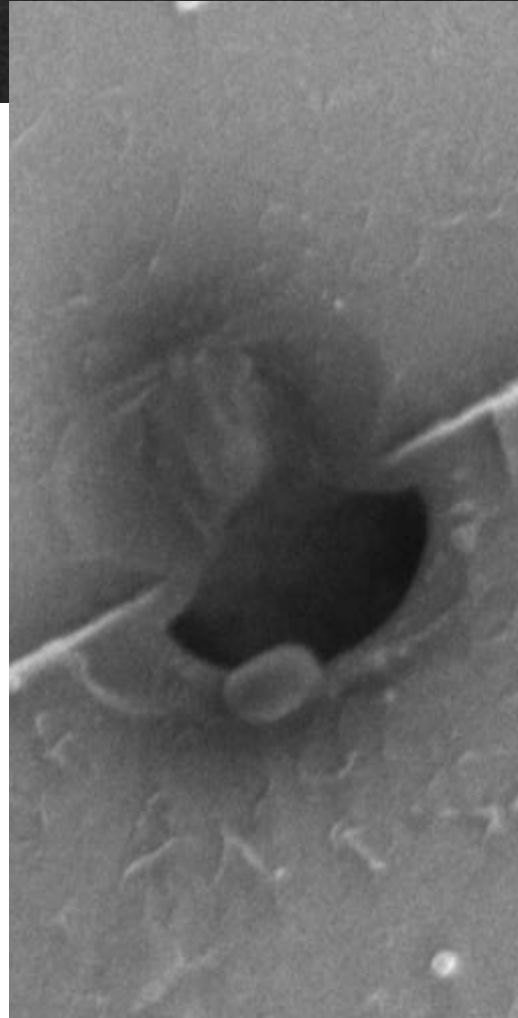
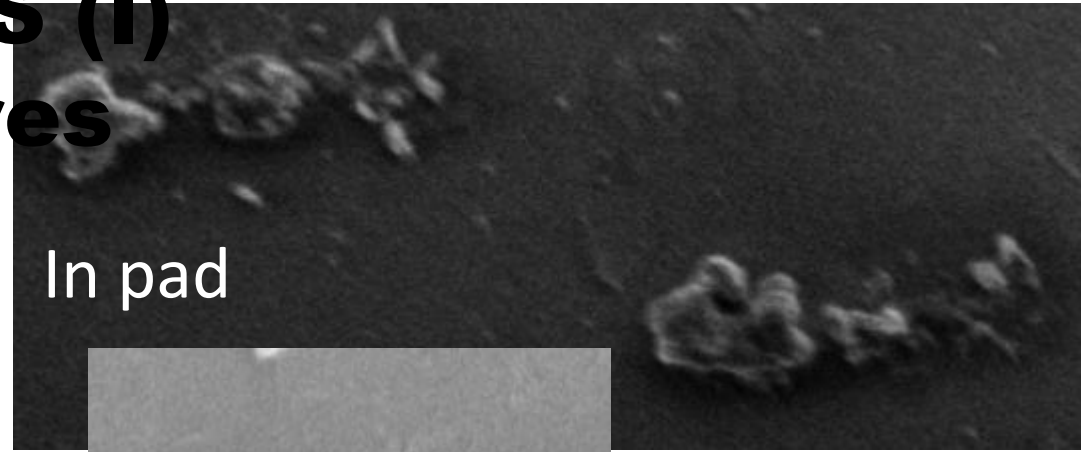

- Damage areas on the pad are clearly visible.
- Damage spots are also observed on the border of pad. It seems that this border region is especially sensitive to the damage.

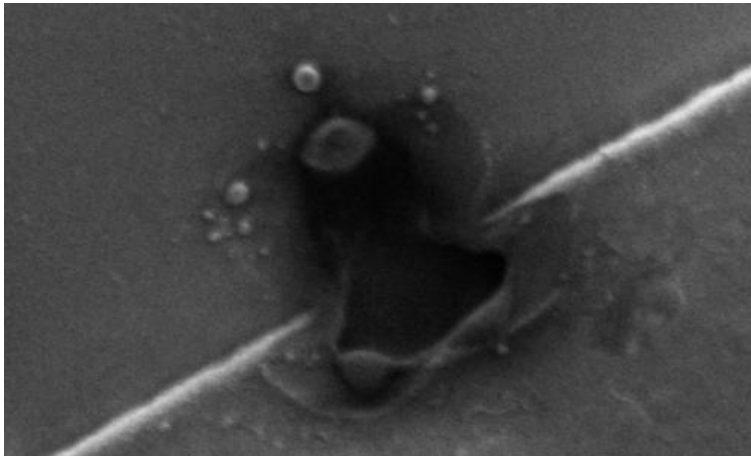

# MEASUREMENTS (II) with PINs (ongoing)

W36 PIN;  $4e14 \text{ cm}^{-2}$

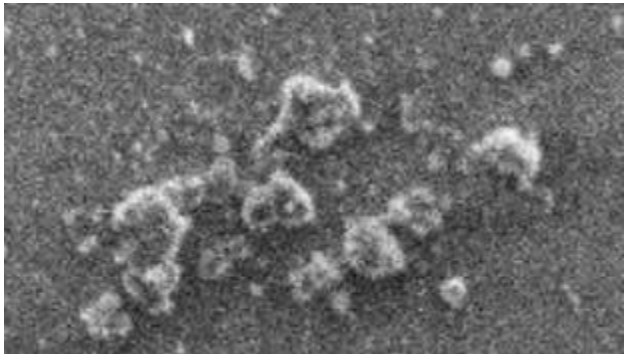

- ✓ PIN survived  $10 \mu\text{W}$  at HV bias of  $330 \text{ V}$ ;
- ✓ Worked well after this test.
- ✓ Some laser induced spots appeared on the pad (aside from some other small spots which were there before experiment).

This allows us to perform additional tests at GR region with laser power of  $10 \mu\text{W}$

- ✓ The sensor worked normally giving the same signal like for pad.

W36 PIN  
 $8e14 \text{ cm}^{-2}$

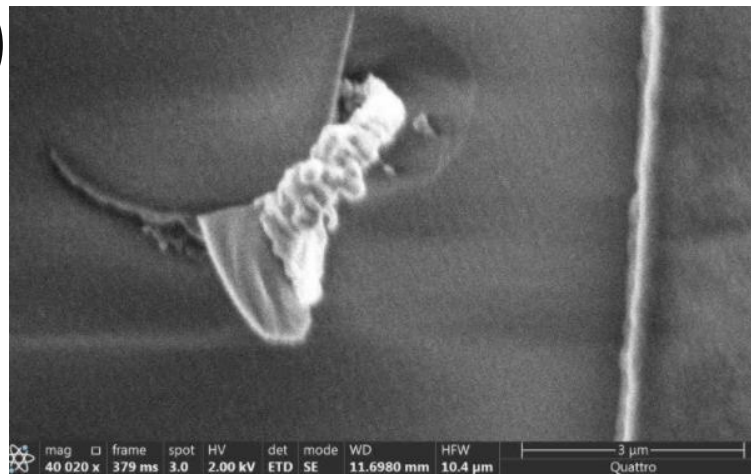

- ✓ This sensor broke down at  $450 \text{ V}$  under  $10 \mu\text{W}$ . Some damage spot appears on the border area even though the laser was focused in the center of pad.

Before exp.

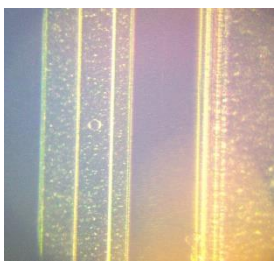

After exp.

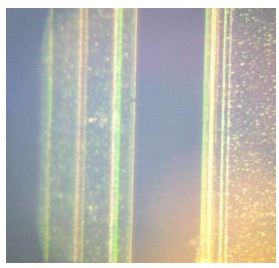



# MEASUREMENTS (II)

## PINs

**W36 PIN**  
 **$2.5e15 \text{ cm}^{-2}$**

- ✓ We achieved to bias of 600 V (after coming to 10  $\mu\text{W}$  at lower bias).
- ✓ However, then PIN broke down completely under 100 nW.
- ✓ Massive damage is clearly visible on pad after that.

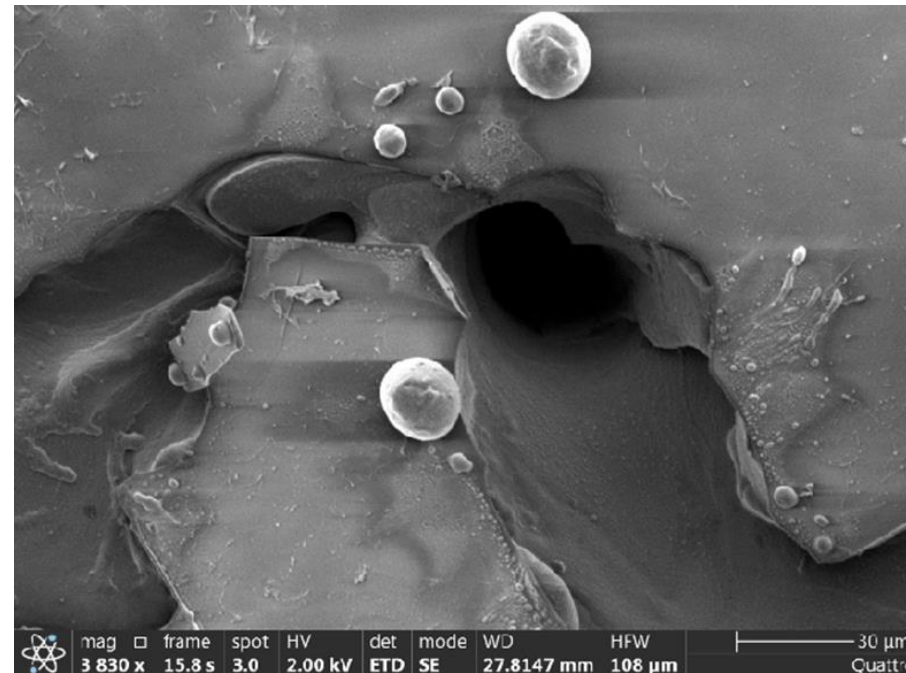
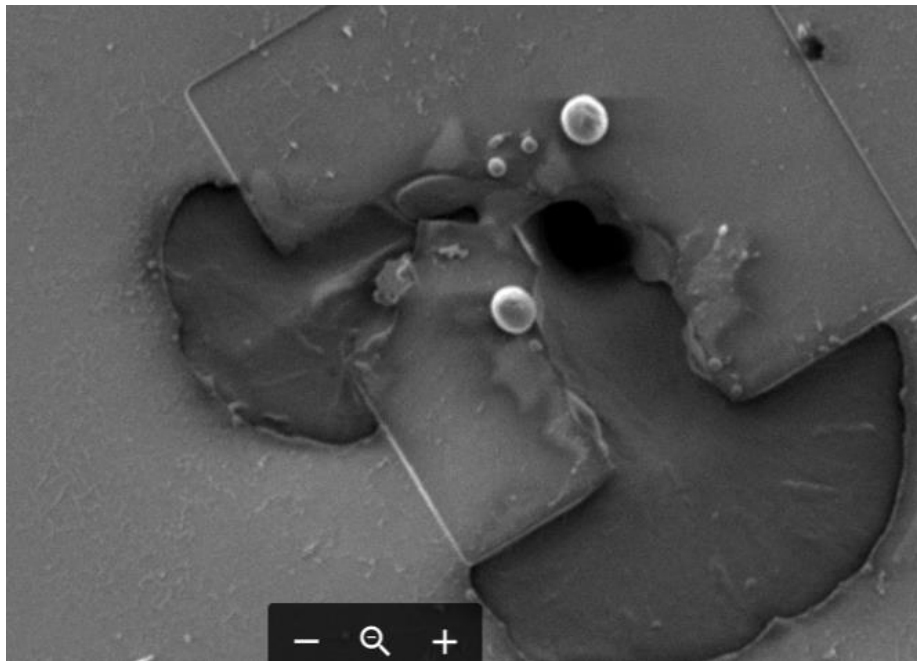

# MEASUREMENTS (II)

## PINs

$1.5 \times 10^{15} \text{ cm}^{-2}$

Sensor was  
broken at:

$HV = 400 \text{ V}$

$P_{\text{laser}} = 6 \mu\text{W}$

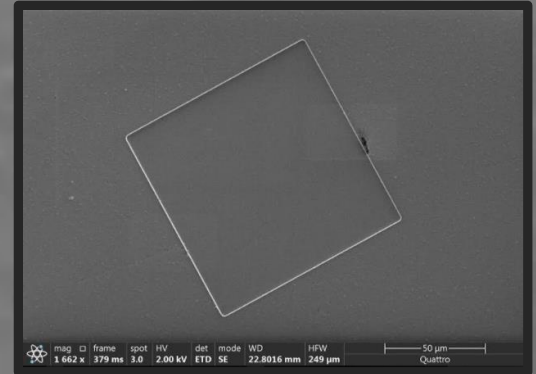

mag	□	frame	spot	HV	det	mode	WD	HFW
10 000 x		15.8 s	3.0	2.00 kV	ETD	SE	38.5397 mm	41.4 μm

10 μm
Quattro

# Summery of results

- ❑ We managed to set up extremely useful facility to study TCT with 50 fs laser of very high energies.
- ❑ The full setup can be operated cooled at  $\sim -30^{\circ}\text{C}$  and flushed with nitrogen.
- ❑ We used 800 nm light with 50 fs pulses at 1 kHz focused in the centre of the LGADs and PINS from the latest HPK-P2 run irradiated to several different fluences 4,8,15,25e14  $\text{cm}^{-2}$ .
- ❑ We focused our studies to establishing the conditions where sensors destructively break down:
  - ❑ Sensors seem to be quite robust up to bias voltages of around 400-500V, where pulse energies of several tens of nJ are required to trigger destructive breakdown – far larger than that experienced during operation at LHC
  - ❑ Both PINs and LGADs seem to be destroyed under this conditions – breakdown likely field related
  - ❑ At high bias voltages the required pulse energy for destruction of the device decreases rapidly – at 680 V only 3pJ is enough to destroy the sensors
  - ❑ Highest irradiated sensors can operate at 1pJ at 720 V – a much finer scan is needed to establish conditions
- ❑ It is clear that at high voltages detectors become sensitive to single highly energetic events, which can lead to destructive breakdown.
- ❑ It seems that all the fatalities occur at the metallization-opening interface!
- ❑ We will establish in the following campaign the voltage needed to break down the sensors using the beam pulse energy corresponding to approximately the maximum possible energies deposition by highly energetic particle interaction.

# ACKNOWLEDGMENT

Special thanks to **Jakob Andreasson** from **ELI Beamlines, CZ – RP4 group** for providing us with fs-laser and instrumentation and a space in their lab that allowed us to perform this experiment.

Special thanks to **Mateusz Rebarz** from **ELI Beamlines, CZ – RP4 group**, the **“father” of the set up**. Thanks also for provided photos and slides.

Special thanks to **Rachael Jack** from **ELI** who did the microscopy!

Thank you to all involved

# BACKUP SLIDES

# Fs-TCT Set up : Motivation

To build unique fs-TCT with both lines, Single Photon Absorption at 800 nm the and Two Photon Absorption at the 1550 nm of fs-laser

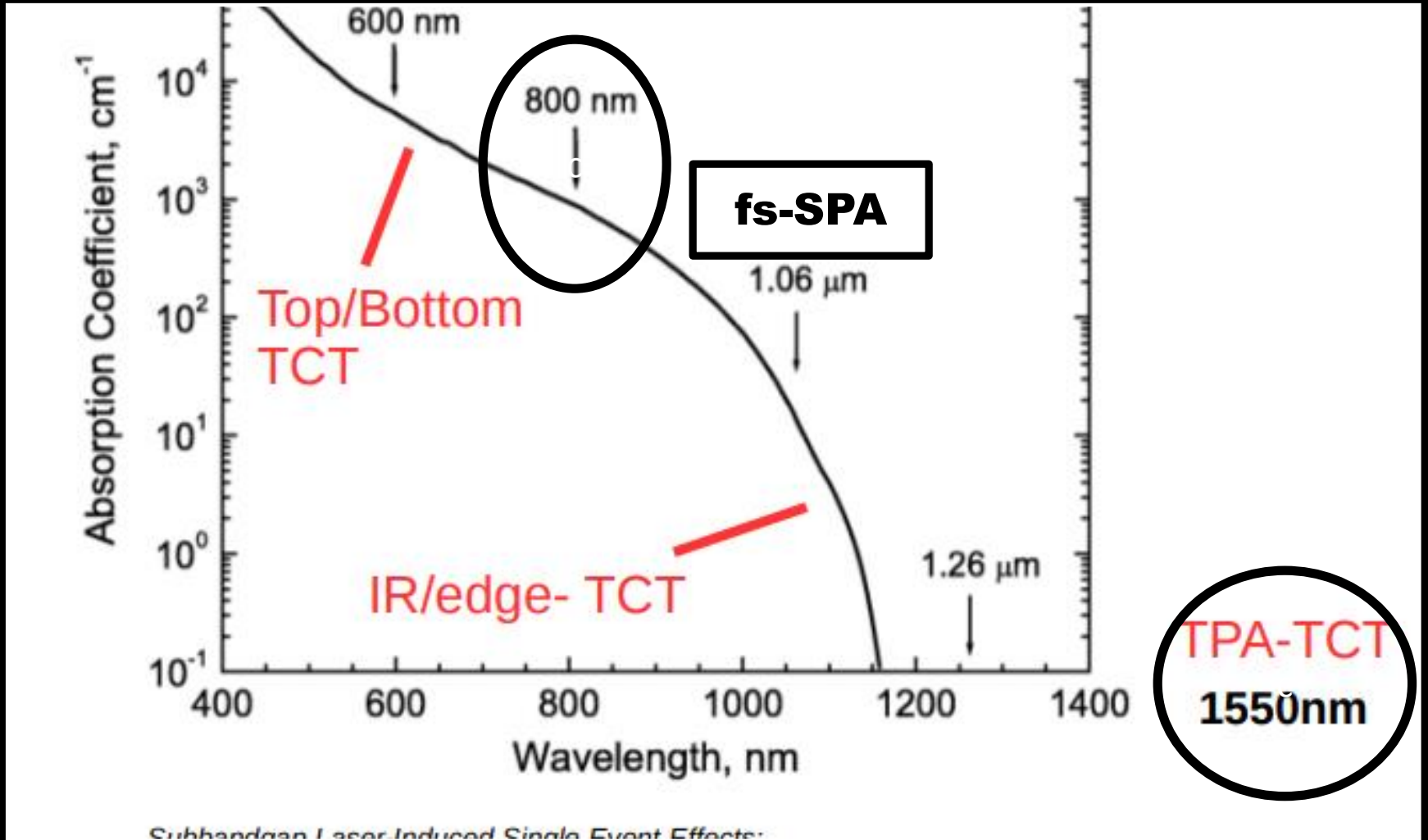

# Beam profile and parameters at 1550 nm (for TPA)

$$P_{measured} = \frac{P}{2} \left[ 1 - \operatorname{erf} \left( \frac{\sqrt{2}(x - x_0)}{w} \right) \right]$$

$w - 1/e^2$  radius Gaussian beam

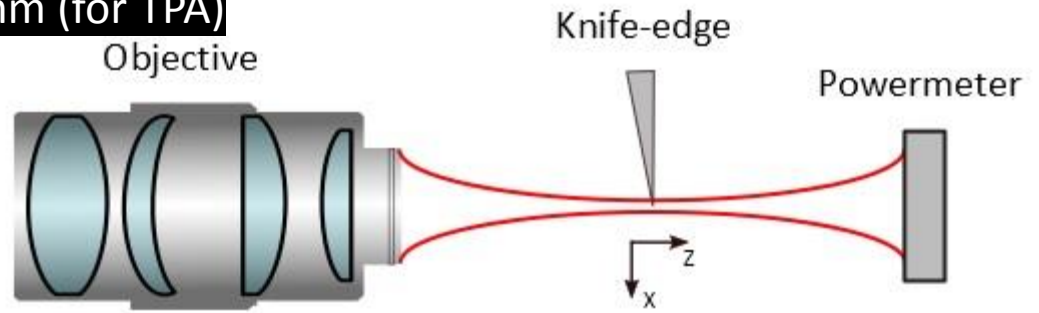

100X Mitutoyo Plan Apo NIR HR  
Infinity Corrected Objective  
 $\lambda = 1550 \text{ nm}$

1.  $P(x)$  measured for series of Z points around focal point
2.  $w(Z)$  obtained by fitting for every Z
3.  $w_0$  and  $Z_R$  obtained by fitting  $w(Z)$  curve

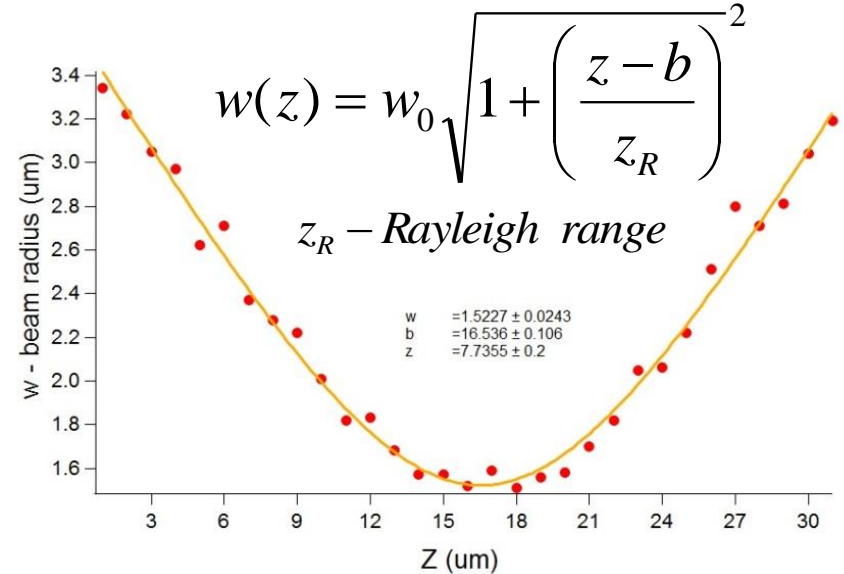
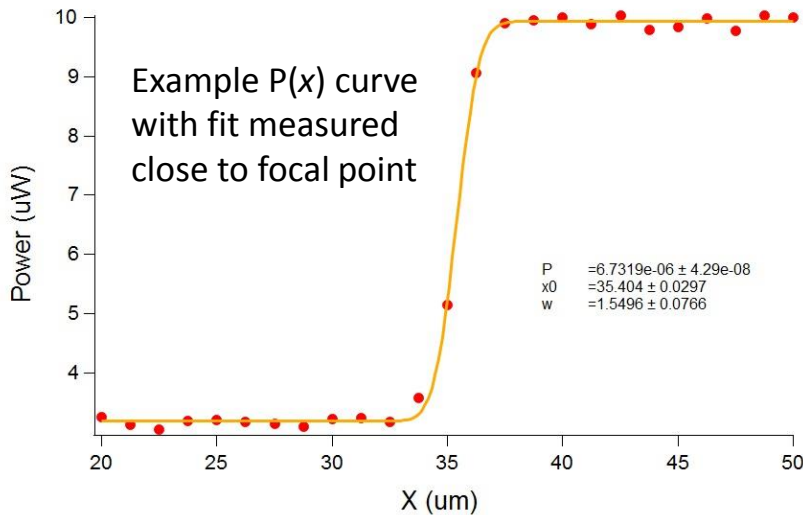

*Final parameters (in air):*

$$w_0 = 1.52 \mu\text{m}$$

$$Z_R = 7.74 \mu\text{m}$$

*In Si : refractive index correction needed*

$$n = 3.48 \text{ at } 1550 \text{ nm}$$

$NA = 0.31$  (nominal  $NA=0.7$  but probably not valid for focal point)

# Schema for Experimental setup: SPA configuration

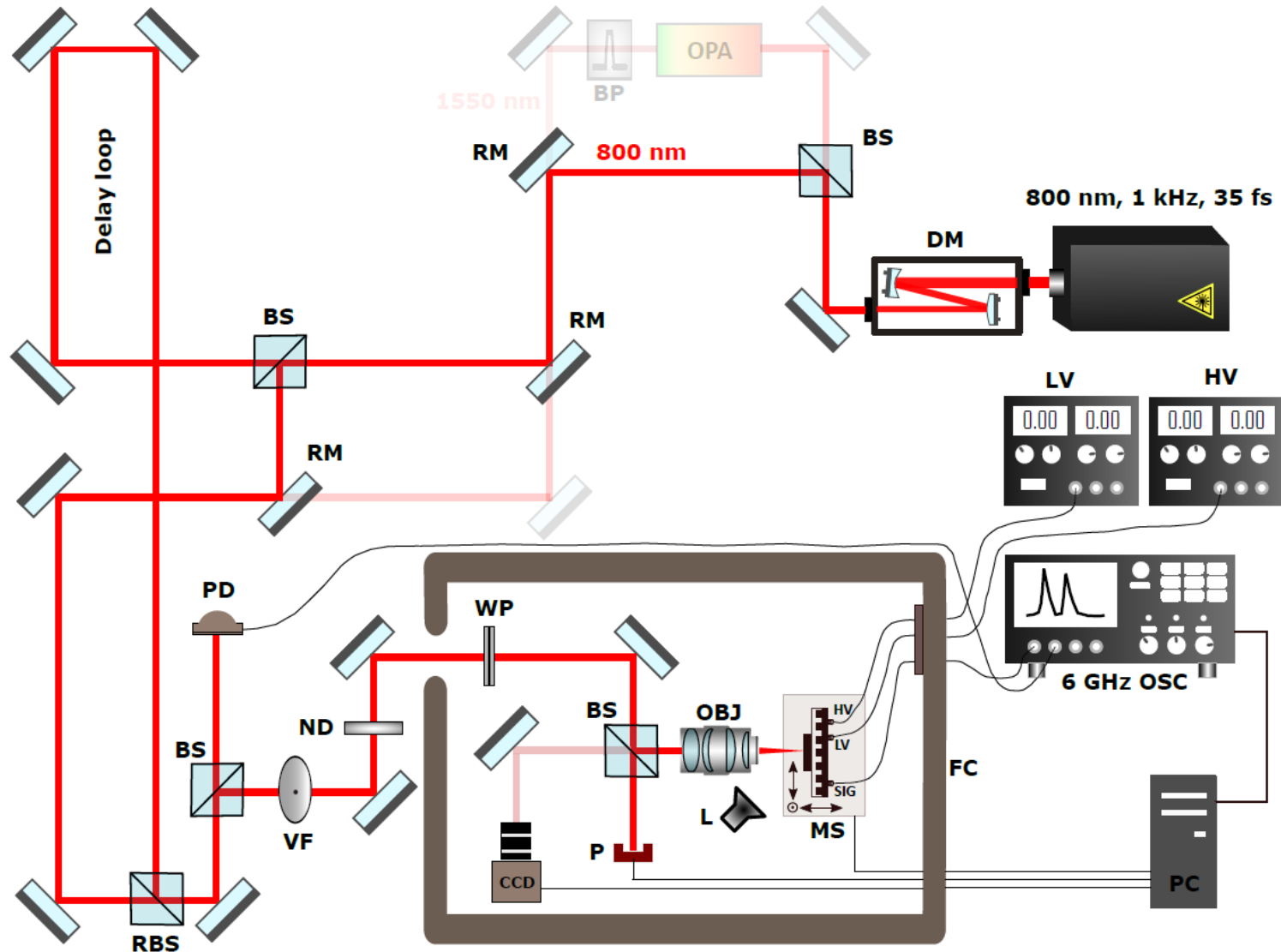

**DM** – demagnifier, **BS** – beamsplitter, **OPA** - optical parametric amplifier, **BP** - bandpass filter, **RM** - removable mirror, **RBS** - removable beamsplitter, **PD** - reference photodiode, **VF** - variable gradient ND filter, **ND** - fixed neutral density filter, **WP** - half waveplate, **P** – powermeter, **OBJ** - 100X objective L-lens, **MS** - motorized XYZ stages, **LV** - low voltage power supply, **HV** - high voltage power supply, **FC** - Faraday cage



# A NEW Experimental setup: TPA configuration

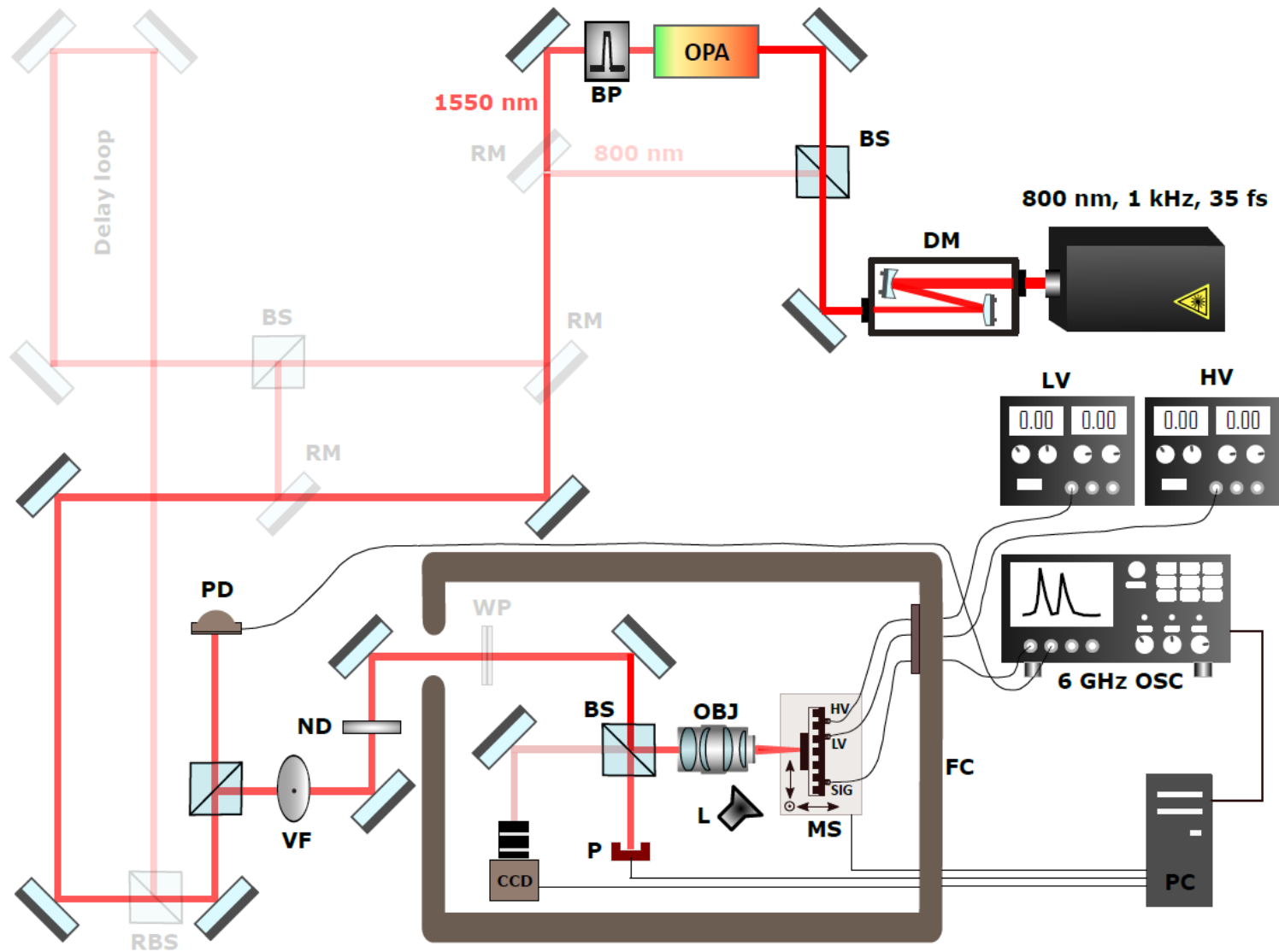

**DM** – demagnifier, **BS** – beamsplitter, **OPA** - optical parametric amplifier, **BP** - bandpass filter, **RM** - removable mirror, **RBS** - removable beamsplitter, **PD** - reference photodiode, **VF** - variable gradient ND filter, **ND** - fixed neutral density filter, **WP** - half waveplate, **P** – powermeter, **OBJ** - 100X objective L-lamp, **MS** - motorized XYZ stages, **LV** - low voltage power supply, **HV** - high voltage power supply, **FC** - Faraday cage

## Comments (set up):

- setup contains a few removable elements on magnetic mounts to quickly change between 800 nm and 1550 nm beam
- for 800 nm optional half wave plate is used to flip polarization (the same S-polarization (vertical) is kept for all measurements)
- beam splitter in the front of objective is exchangeable, different ones are used for 800 and 1550 nm to give 50/50 split in both cases
- power is measured after the beam splitter (it enables constant monitoring of power during measurements)
- at 1550 nm power is measured by S132C Thorlabs power meter
- at 800 nm power is measured by PD300 Thorlabs power meter (much more sensitive at this wavelength)
- if the most sensitive power meter is not enough in SPA (that was the case in mortality study where pW power gives already high signal) the additional ND filter OD=1 is insert in the front of objective (the actual power is attenuated by factor 10 in comparison to measured value)
- InGaAs reference diode is used to correct the laser fluctuations (it's important especially for long measurements: for xy scans for example) and to trigger the scope
- CCD camera with imaging lens (plus illuminating lamp) monitor when exactly we shoot. This system is used to precisely align position of detector and then is off (in principle illuminating lamp is off) during measurements



# W36 1.5e15

## 2<sup>nd</sup> Measurement

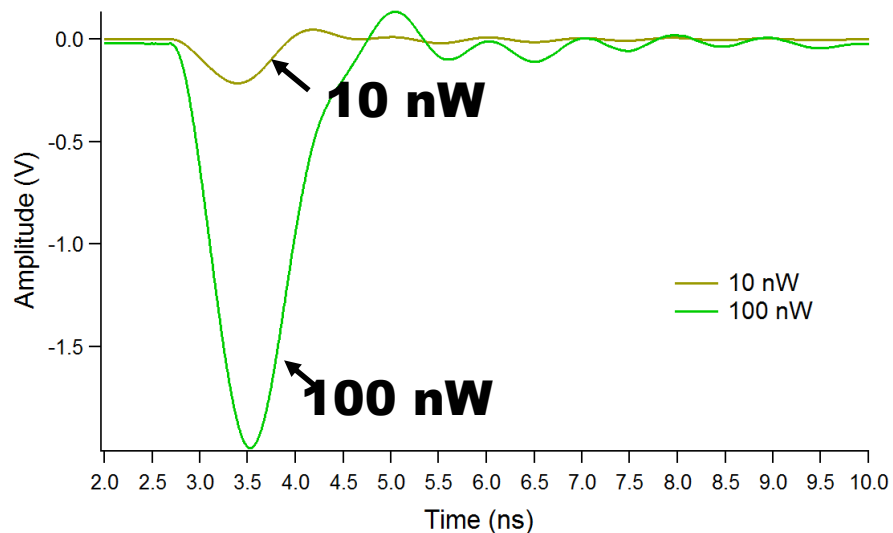
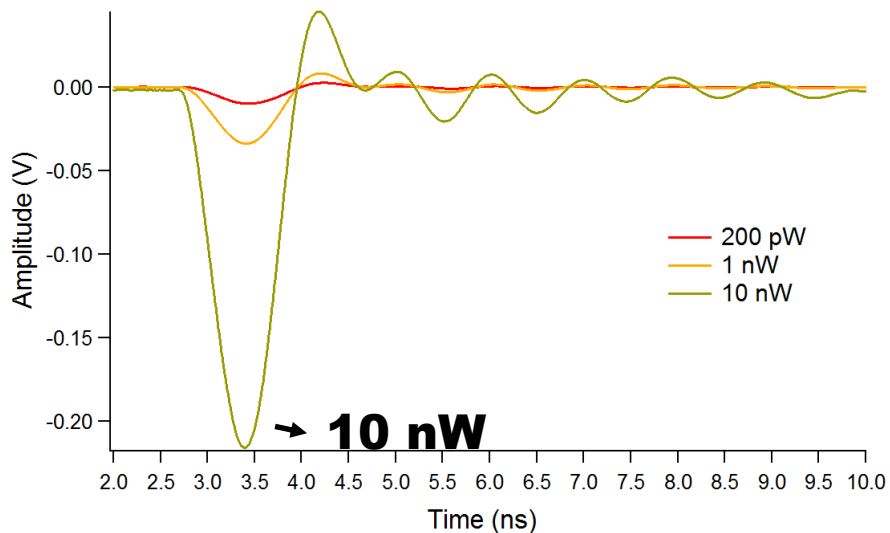

Signal for different laser powers at 450 V

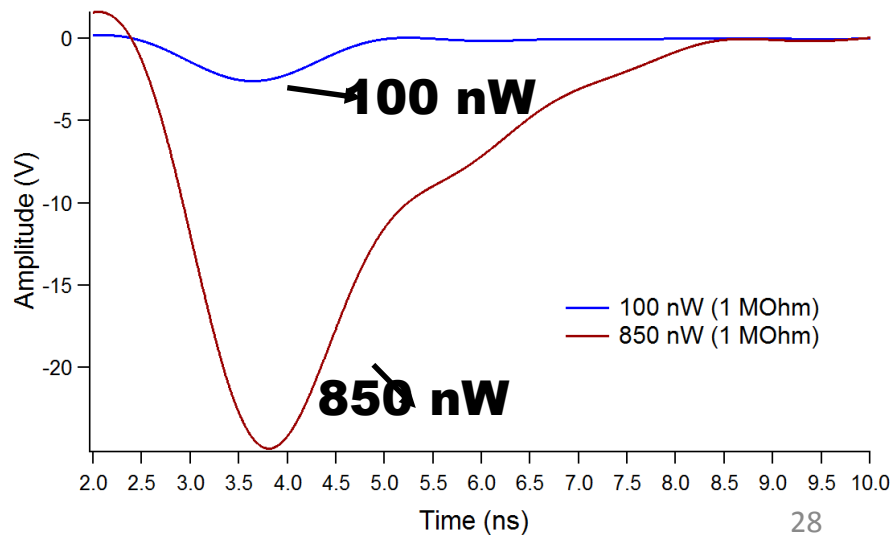

# W36 LGAD ; $8e14 \text{ cm}^{-2}$ ; HV=500 V

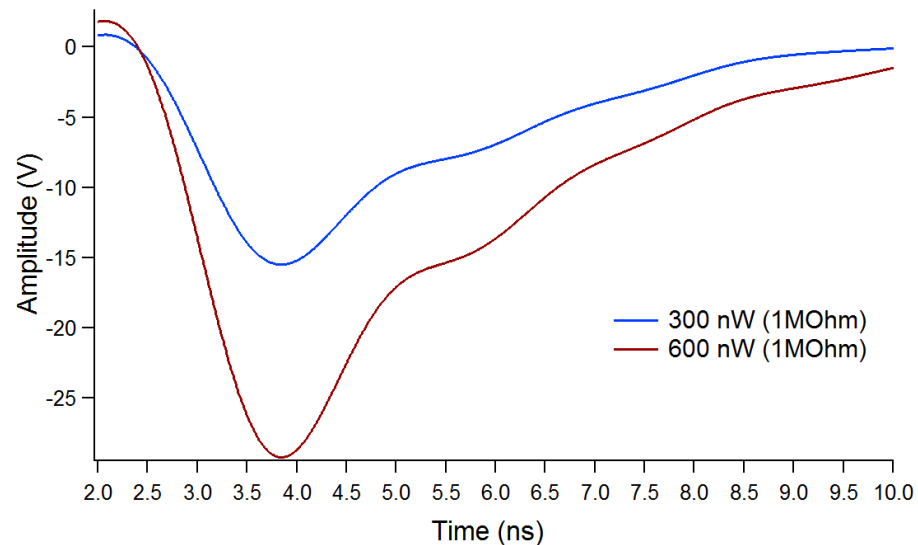
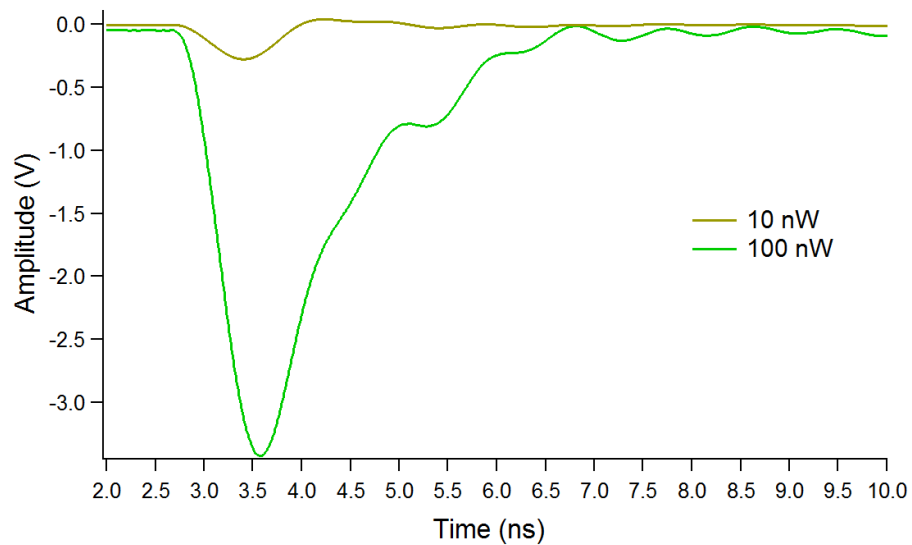
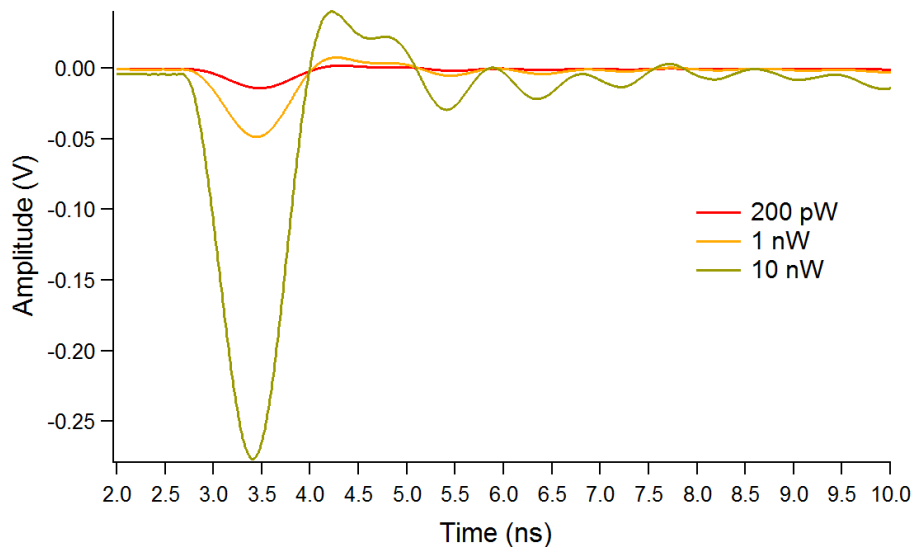

# The beam-detector alignment procedure

Imaging system is based on the same objective we use for the focusing the beam. It means that we can see only very small area (100X magnification).

It fits perfectly to the size of pad which is our target. Moreover we know that sharp image of the pad means that we are in the focal plane of the objective.

More precisely the surface of pad is in the focal plane and also our beam is maximally focused on the surface. Finding this position is starting point of alignment.

This is very precise method because just a few micrometres off the focal plane we lose sharp image what is clearly visible. It also helps to align the tilt of the sample.

examples:

In the first picture ( at the top) we can see sharp image of whole area. In the second picture the right side is blurry what means that the sample is tilted.

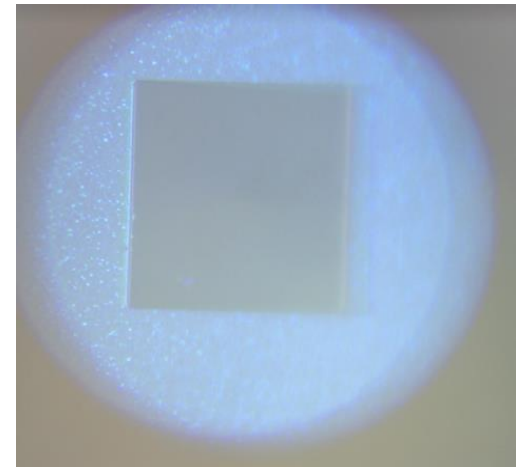
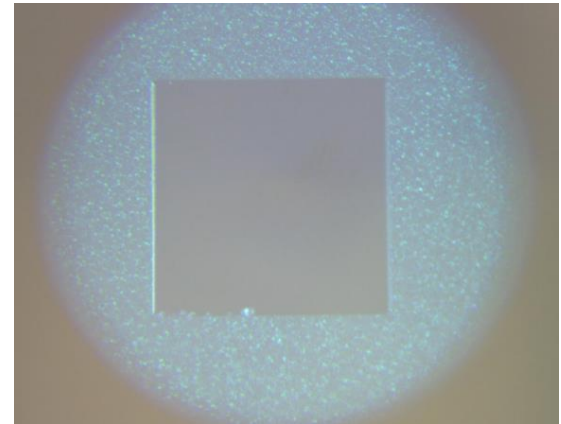

## Some more explanations from Mateusz

### 1. XY alignment

Typically if I illuminate the sample positioned in the centre (like in the pictures) I see the signal. For low intensity (that is always starting point) I don't see the beam. Scattering is not high and our camera is not very sensitive for 800 nm (that can be improved with different camera). To be sure that I illuminate the center of pad I scan X and Y directions and observe the signal. When I lose the signal I know that I'm on the edge of pad. In this way I found boundaries and I know where is the centre of pad.

## Some more explanations from Mateusz (continuation)

### 2. Z alignment

This is of course very critical for TPA where I always recorded z-scan to find maximal signal. Here the focal point must be inside the sample (not on the surface).

In case of SPA I didn't record any z-scan (I will do it next time) but here the signal is not sensitive vs z position in reasonable range. I always scan few hundreds um to see if the signal changes but it doesn't. Of course at certain moment it starts decrease because the beam is divergent and become bigger than pad (not all photons go to the sensor). I always measure the maximal signal but actually it's constant at least +/- 100 um from the focal plane (on the surface) and I don't see difference.



## Some more explanations from Mateusz (continuation)

### 3. Beam visibility

As I said it's a bit tricky with camera we use. When the lamp is off (experimental condition to avoid influence on the results) then probably relatively low intensity can be visible on camera but we can't see the pad then. Anyway I will try to find compromise or take some photos with lamp on/off. Now it's also easier to use higher intensities because the sensors are dead anyway so I don't need to worry I damage them.

However high intensities can be misleading because beam looks bigger than it really is in the sample due to high scattering.

In general the imaging system is far from perfect (some aspects can be certainly improved) but even in the present form is essential because only thanks to it we can shoot in our target.