

# CLIC sensitivity to invisible scalar decays

**K.Mękała**, A.F. Żarnecki, B. Grządkowski, M. Iglicki

Faculty of Physics, University of Warsaw

International Workshop on Future Linear Colliders, LCWS2021  
17.03.2021

Mekala, K., Zarnecki, A.F., Grzadkowski, B., Iglicki, M.,  
*Sensitivity to invisible scalar decays at CLIC*,  
Eur. Phys. J. Plus **136**, 160 (2021),  
<https://doi.org/10.1140/epjp/s13360-021-01116-5>

# Higgs production

Two main Higgs production channels at CLIC:

- $ZH$  production dominant at 380 GeV
- $H\nu\nu$  channel dominant at higher energy stages

$ZH$  channel allows for event selection independent on the Higgs decay channel  $\rightarrow$  sensitive also to invisible decays

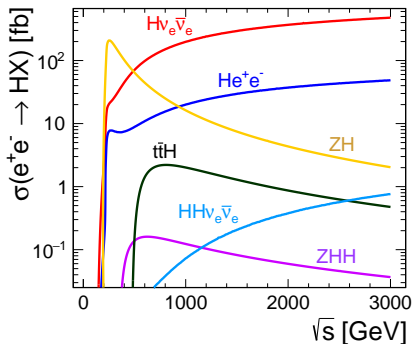
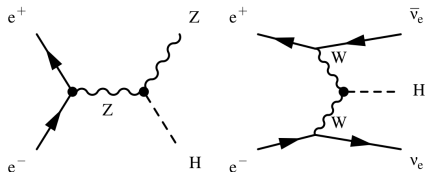

SM(-like) Higgs boson decay to invisible states (Dark Matter?)

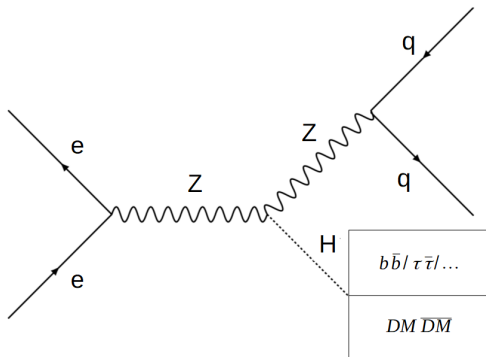

Signature of invisible Higgs decay:

- two jets consistent with hadronic  $Z$  decay (higher statistics)
- missing energy-momentum consistent with production of invisible massive state of 125 GeV

# Background processes considered

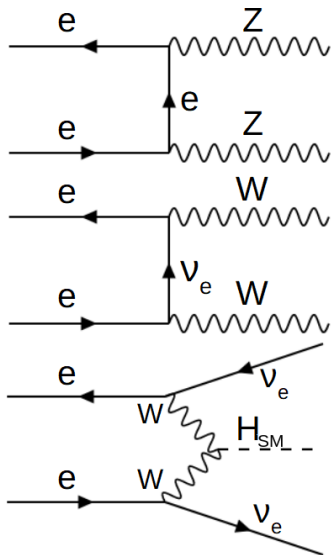
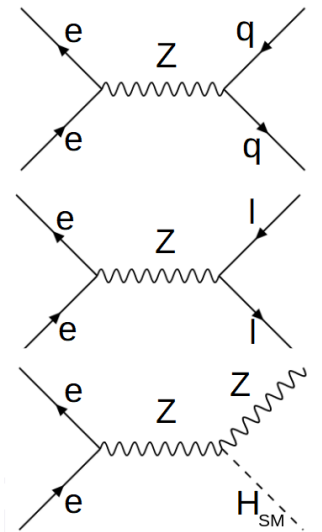

# Simulation framework

- event samples generated with WHIZARD 2.7.0
  - signal:  $H + qq$  production with Higgs defined as stable
  - SM Higgs boson production:  
 $H + qq, H + ll, H + \nu\nu$  (with 100% SM decays)
  - non-Higgs background:  $qq, ll, qqqq, qqll, qq\ell\nu, qq\nu\nu, qq\ell\nu\nu$
  - beamstrahlung and EPA photon interactions (WHIZARD 2.8.5):  
 $qq, qq\nu, qqqq, qqll, qq\ell\nu, qq\nu\nu$
- CLIC energy spectra for **380** GeV
- CLIC integrated luminosity of **1000** fb<sup>-1</sup> (unpolarised)
- detector simulation and event reconstruction with DELPHES, using modified *CLICdet\_Stage1* cards (to make Higgs invisible in the detector)
- required topology: two jets reconstructed with VLC algorithm ( $R = 1.5, \beta = \gamma = 1$ )

# Signature of $e^+e^- \rightarrow HZ \rightarrow jj + inv$

Two-jet events without electrons, muons, or isolated photons...

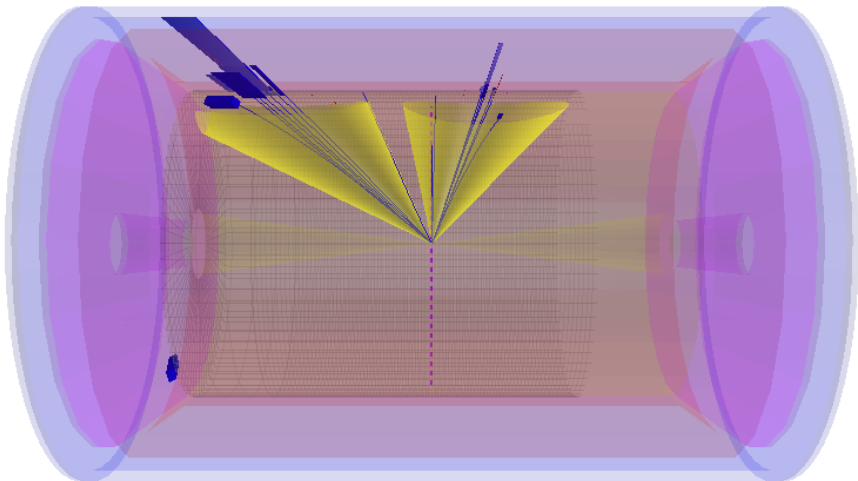

Preselection cuts were used to select events with proper signature and kinematics consistent with invisible Higgs boson decay:

- No isolated electrons, muons or photons reconstructed with energy above 2 GeV, 3 GeV and 5 GeV respectively
- Energy “lost” in the jet clustering below 10 GeV
- At least 2 charged particles in each jet
- Two jet topology:  $y_{23} < 0.01$  and  $y_{34} < 0.001$
- Jet invariant mass:  $80 < M_{jj} < 100$  GeV (Z mass)
- Dijet emission angle:  $|\cos \Theta_{jj}| < 0.8$  (Z direction)

# Preselection efficiency

<i>Event class</i>	<i>Efficiency</i>	<i>Events after cuts</i>
<b>Non-Higgs background</b>	<b>0.21%</b>	<b>115,398</b>
<i>leading channels:</i>		
$qq\nu\nu$	20.47%	64,965
$qq\nu$	0.60%	33,065
$qq$	0.08%	16,684
<b>Photon interactions</b>	<b>5.11%</b>	<b>201,492</b>
<i>leading channels:</i>		
$\gamma^{EPA} e^+ \rightarrow qq\nu$	6.20%	56,489
$\gamma^{EPA} e^- \rightarrow qq\nu$	6.32%	56,054
$\gamma^{BS} e^+ \rightarrow qq\nu$	6.68%	42,823
$\gamma^{BS} e^- \rightarrow qq\nu$	6.73%	42,707
<b>SM Higgs decays</b>	<b>0.86%</b>	<b>1313</b>
<b><math>H + qq</math> invisible decays</b>	<b>43.56%</b>	<b>35,920</b>



# Preselection

Recoil mass distribution after preselection cuts  
for  $1000 \text{ fb}^{-1}$  collected at 380 GeV, assuming  $\text{BR}(H \rightarrow \text{inv}) = 1\%$  for signal

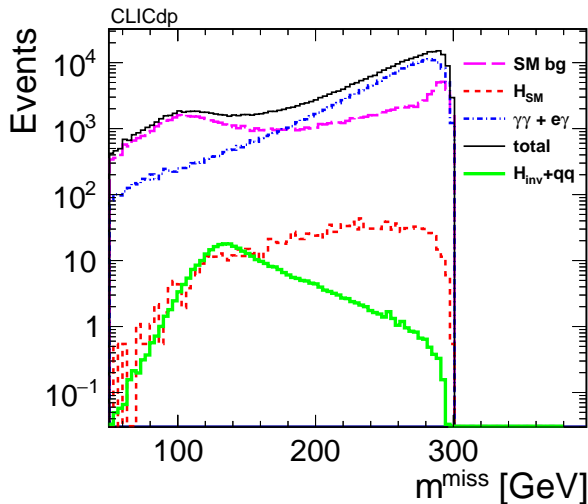

# Selection

Final event selection based on the multivariate analysis (5 variables).  
for  $1000 \text{ fb}^{-1}$  collected at 380 GeV, assuming  $\text{BR}(H \rightarrow \text{inv}) = 1\%$  for signal

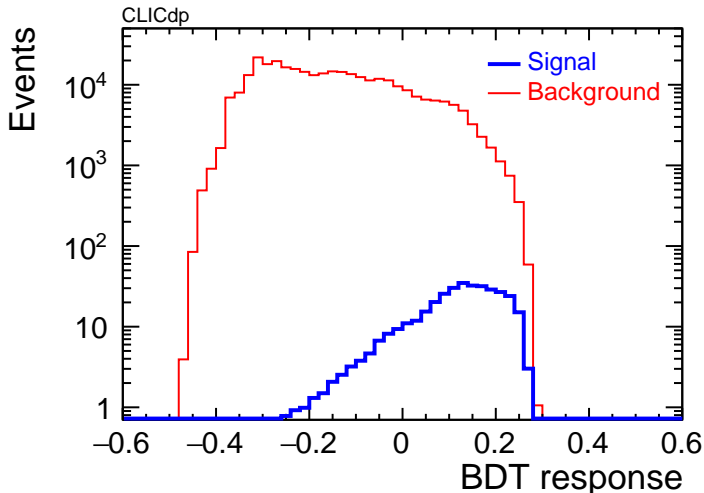

95% C.L. limit expected for  $1000 \text{ fb}^{-1}$  collected at 380 GeV:

$$BR(H \rightarrow inv) < 1.0\%$$

Assuming **no excess** above predicted SM background is observed

## Limits on new scalar production – CLIC380

Same approach can be used to search for production of  $H'$  state in the process  $e^+e^- \rightarrow ZH' \rightarrow qq + inv$

( $H'$  generated in WHIZARD as SM-Higgs particle with a different mass)

## Limits on new scalar production – CLIC380

Same approach can be used to search for production of  $H'$  state in the process  $e^+e^- \rightarrow ZH' \rightarrow qq + inv$

( $H'$  generated in WHIZARD as SM-Higgs particle with a different mass)

Expected limits on the  $H'$  production cross section, relative to SM, for CLIC at 380 GeV, assuming  $BR(H' \rightarrow inv) \approx 100\%$ :

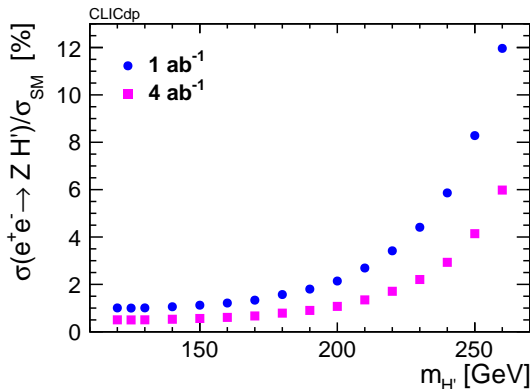

# Limits on new scalar production – CLIC1500

Similar analysis can be performed for CLIC at 1.5 TeV ( $2500 \text{ fb}^{-1}$ ):

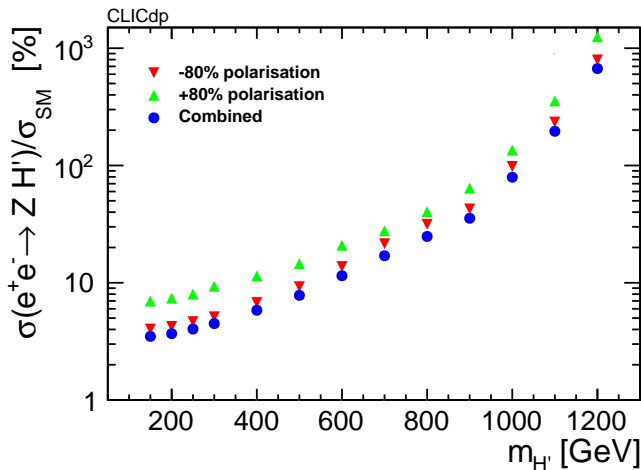

# Limits on new scalar production

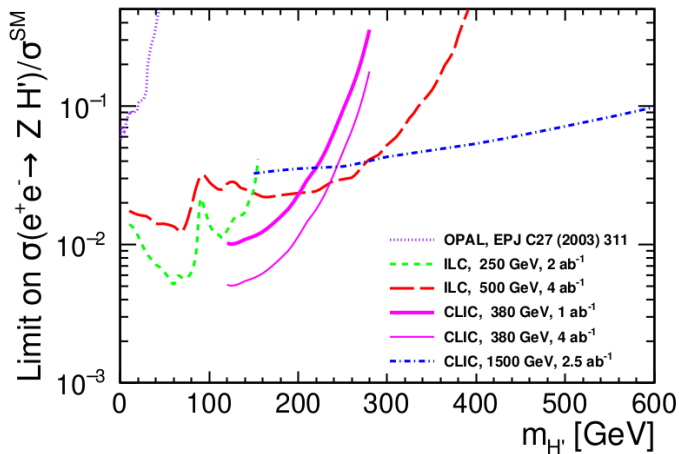

# Interpretation

In Higgs-portal models, new scalar field  $\phi$  coupling to dark matter particles can mix with the SM Higgs field  $h$  resulting in two mass eigenstates:

$$\begin{pmatrix} H \\ H' \end{pmatrix} = \begin{pmatrix} \cos \alpha & \sin \alpha \\ -\sin \alpha & \cos \alpha \end{pmatrix} \begin{pmatrix} h \\ \phi \end{pmatrix}$$

If  $\alpha \ll 1$ ,  $H$  is SM-like (the observed 125 GeV state), but it can also decay invisibly via  $\phi$  component (BR  $\sim \sin^2 \alpha$ ).

If  $H'$  is also light, it can be produced in  $e^+e^-$  collisions in the same way as the SM-like Higgs boson; invisible decays dominate.

We consider Vector-fermion dark matter model (VFDM) [[arXiv:1710.01853](https://arxiv.org/abs/1710.01853)]



# Interpretation

Limit on the invisible decays of the 125 GeV Higgs boson ( $H$ ) can be interpreted in terms of the VFDM mixing angle limits.

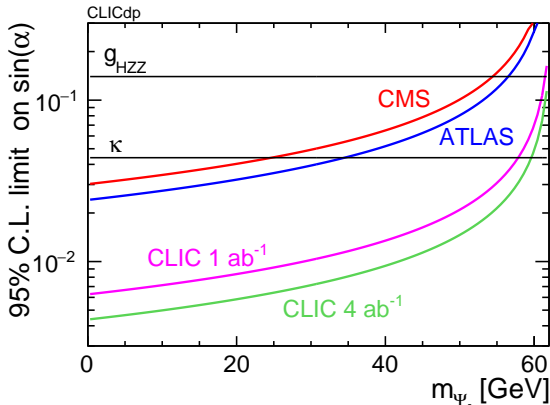

Based on WHIZARD calculations assuming  $g_X = 1$ .

# The VFDM model

Expected limits on the  $H'$  production cross section can also be translated within the VFDM model into limits on the mixing angle  $\alpha$ .

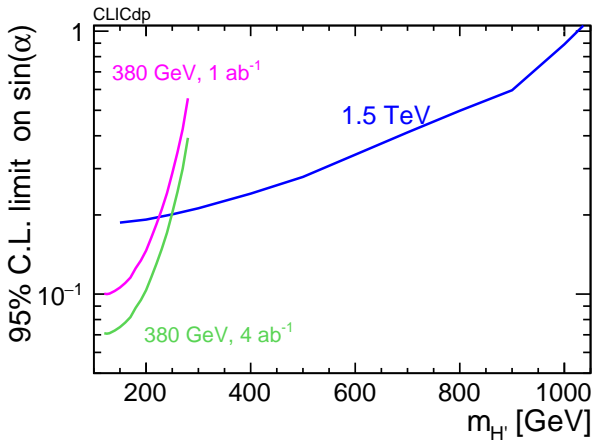

# Conclusions

- 1 We searched for invisible Higgs boson decays using WHIZARD event generation and fast simulation with DELPHES, including  $\gamma$ -induced background.
- 2 CLIC running at 380 GeV (lum.  $1 \text{ ab}^{-1}$ ) can constrain the invisible decays of the SM Higgs boson to 1%.
- 3 The study can be extended to search for extra scalars at CLIC operating at 380 GeV and 1.5 TeV.
- 4 The results can be interpreted in terms of mixing angles of Higgs-portal models.

# References



A. Ahmed, M. Duch, B. Grzadkowski, and M. Iglicki.

Multi-component dark matter: the vector and fermion case.

*The European Physical Journal C*, 78(11):905, Nov 2018.

doi: 10.1140/epjc/s10052-018-6371-2.

URL <https://doi.org/10.1140/epjc/s10052-018-6371-2>.



K. Mekala, A. F. Zarnecki, B. Grzadkowski, and M. Iglicki.

Sensitivity to invisible scalar decays at CLIC.

*The European Physical Journal Plus*, 136(2):160, 2021.

doi: 10.1140/epjp/s13360-021-01116-5.

URL <https://www.doi.org/10.1140/epjp/s13360-021-01116-5>.



M. A. Thomson.

Model-independent measurement of the  $e^+e^- \rightarrow HZ$  cross section at a future  $e^+e^-$ -linear collider using hadronic Z decays.

*The European Physical Journal C*, 76(2):72, 2016.

doi: 10.1140/epjc/s10052-016-3911-5.

URL <https://doi.org/10.1140/epjc/s10052-016-3911-5>.

# BACKUP: preselection cuts

