



# ILD: Status and Plans

Ties Behnke, March 17, 2021



# ILD: a multi purpose detector for the ILC



~15 m

- Excellent vertexing very close to the IP
- Hybrid tracking system optimized for excellent resolution at high energies and ultimate efficiency over a broad momentum range
- Particle flow as the key design driver

Up to HCAL, all inside solenoidal coil of 3-4 T

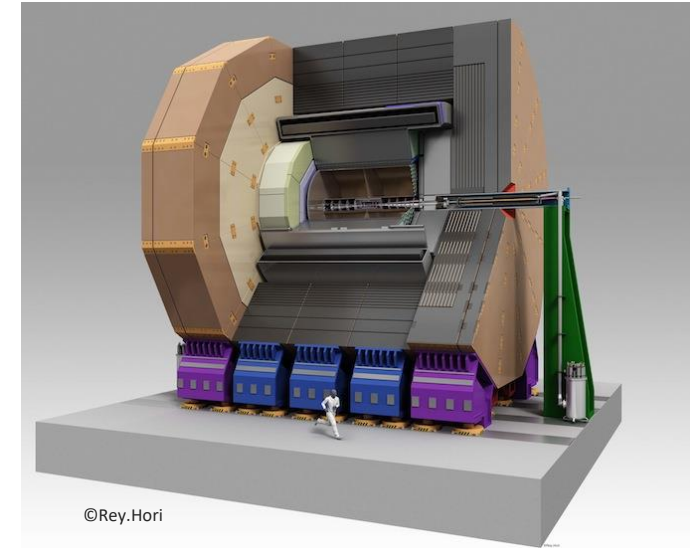
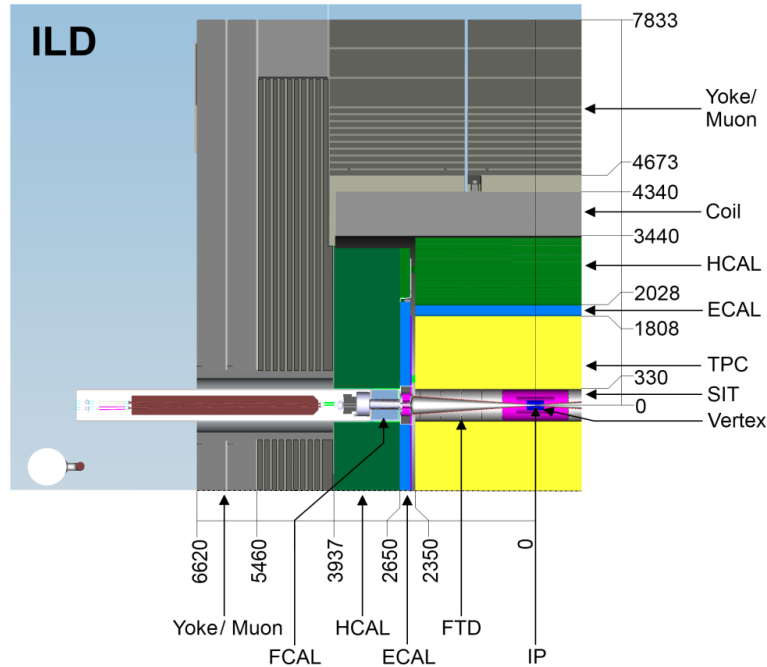

©Rey.Hori

Low mass tracker

Radiation Length

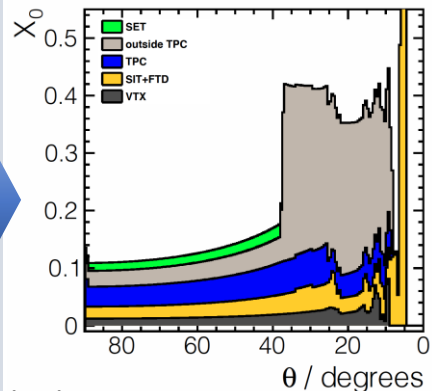

Interaction Length

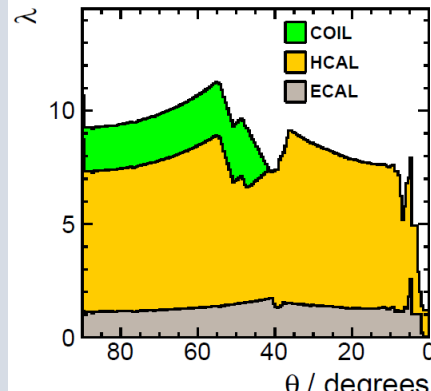

ILD Cost Fraction (IDR-L, 2020)

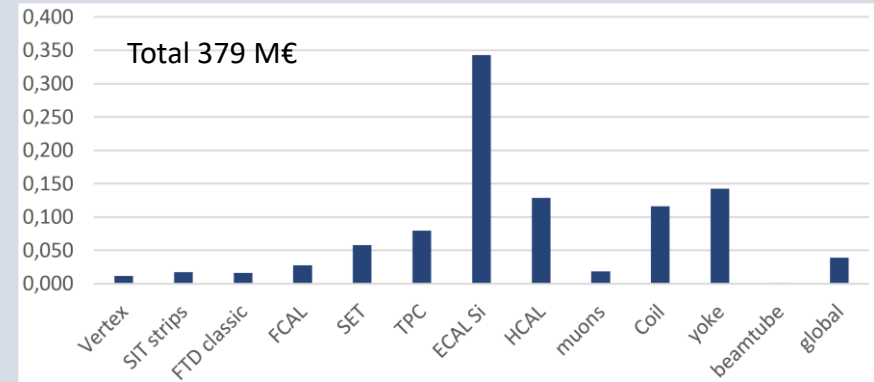

[arXiv:2003.01116](https://arxiv.org/abs/2003.01116)

3/17/2021

LCWS 2021 | ILD: Status and Plans

# ILD Design Goals

Slide heavily borrowed from Tomohiko Tanabe's 2020 ICHEP talk

## Detector Requirements

- Impact parameter resolution  $\sigma(d_0) < 5 \oplus 10 / (p[\text{GeV}] \sin^{3/2}\theta) \mu\text{m}$  ~ LHC / 2
- Transverse momentum resolution  $\sigma(1/p_T) = 2 \times 10^{-5} \text{ GeV}^{-1} \oplus 1 \times 10^{-3} / (p_T \sin^{1/2}\theta)$  ~ LHC / 10
- Jet energy resolution 3-4% (around  $E_{\text{jet}} \sim 100 \text{ GeV}$ ) ~ LHC / 2
- Hermeticity  $\theta_{\text{min}} = 5 \text{ mrad}$  ~ LHC / 3

## Physics Studies

$H \rightarrow bb, cc, \tau\tau$

Total  $\sigma(e+e \rightarrow ZH)$

$Z/W/H \rightarrow jj$ ;  $H \rightarrow \text{invisible}$

$H \rightarrow \text{invisible}$ ; BSM

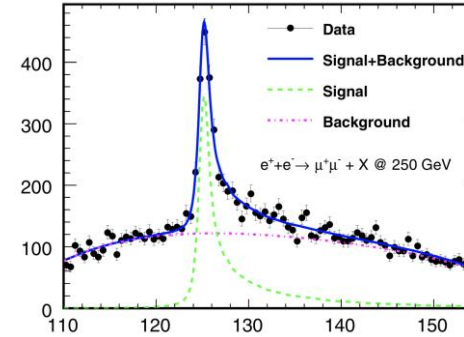
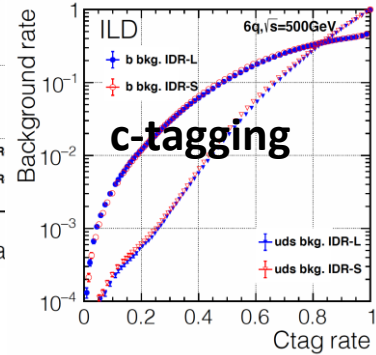
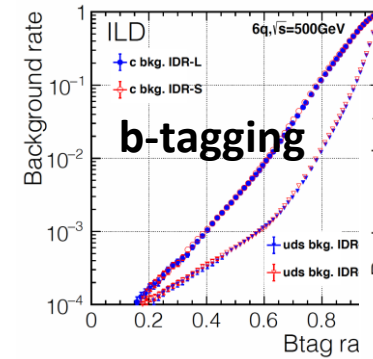

Higgs recoil against  $Z \rightarrow \mu\mu$

[arXiv:2003.01116](https://arxiv.org/abs/2003.01116)

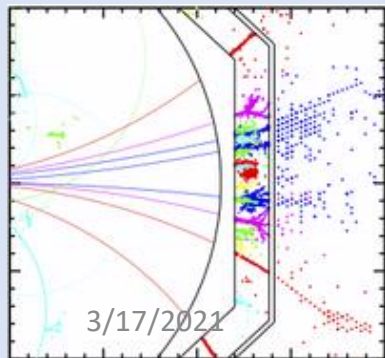
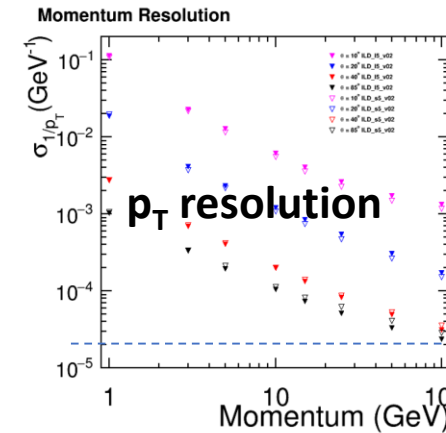

ILD is optimized around **Particle Flow and Precision:**

- Highly granular calorimeters
- Low-mass trackers (Si and gaseous)
- Highly sophisticated software reconstruction
- Excellent vertexing capabilities

LCWS 2021 | ILD: Status and Plans

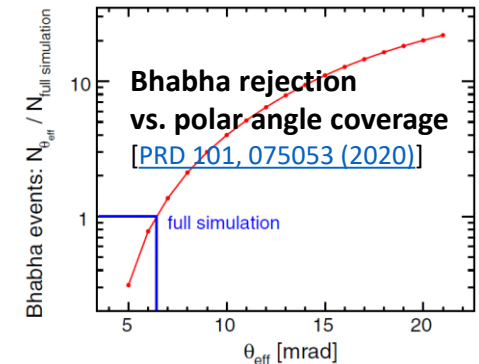
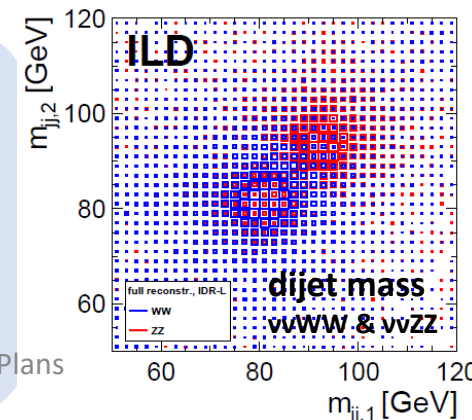

# The current state of the art in ILD



The work of ILD over the last years has been documented in the IDR and published this year.

Signed by 302 authors from 62 institutes

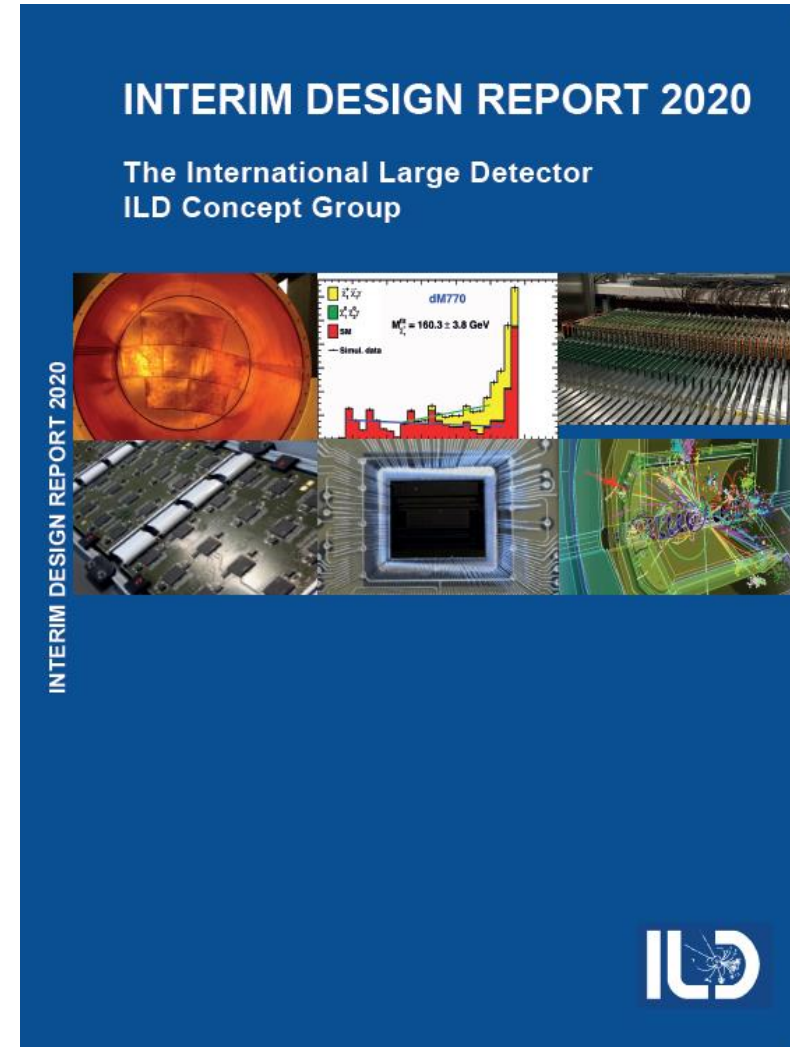
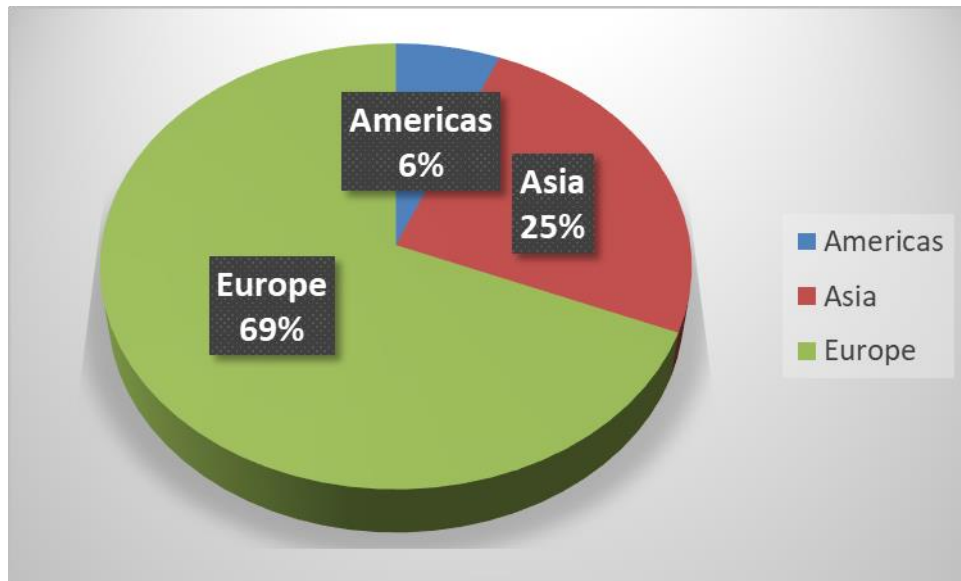

<https://arxiv.org/abs/2003.01116>

# Subdetector Status



ILD has a concept of the detector,  
well defined  
with technological options where sensible

The main components of ILD  
have been validated and  
beam-tested.

A coherent System design has  
been developed.

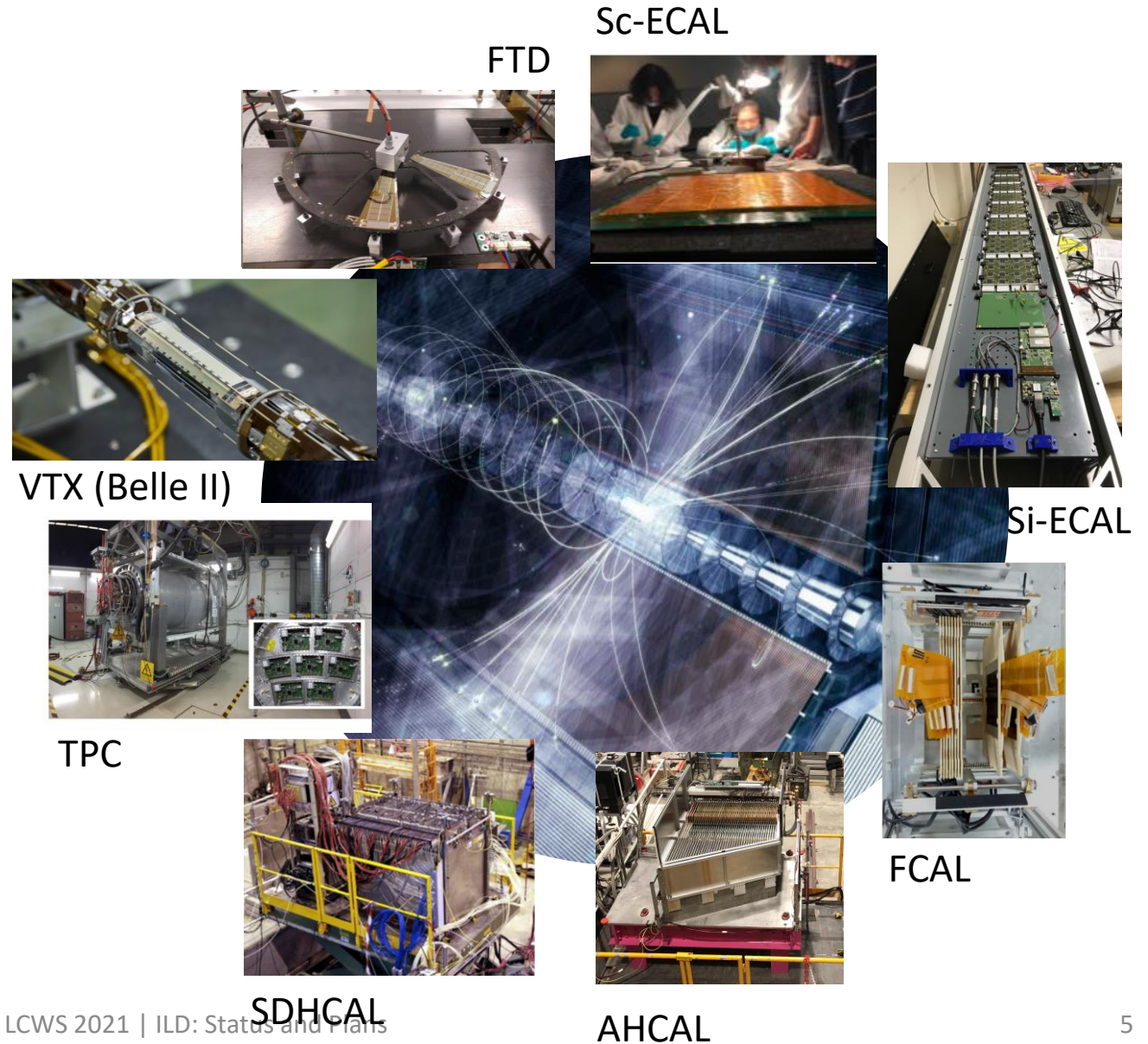

# ILD as an organisation

ILD executive team (2017-2021)

Ties Behnke



Kiyotomo Kawagoe

Technical working group

Software working group

Physics working group



Claude Vallee,

Karsten Buesser



Frank Gaede, Daniel Jeans



Keisuke Fujii,

Jenny List



Henri Videau



Alberto Ruiz



LCWS 2021, ILD: Status and Plans

Yasuhiro Sugimoto



Graham Wilson

# ILD as an organisation

ILD executive team (2021-2023)

Ties Behnke



Kiyotomo Kawagoe

Technical working group



Mary-Cruz Fouz, Karsten Buesser

Software working group



Frank Gaede, Daniel Jeans

Physics working group



Keisuke Fujii, Filip Zarnecki

+ four elected members from the ILD community. Elections for these positions are in progress.



Picture from the last in-person ILD meeting (2019) in pre-Corona times

# Opportunities in ILD

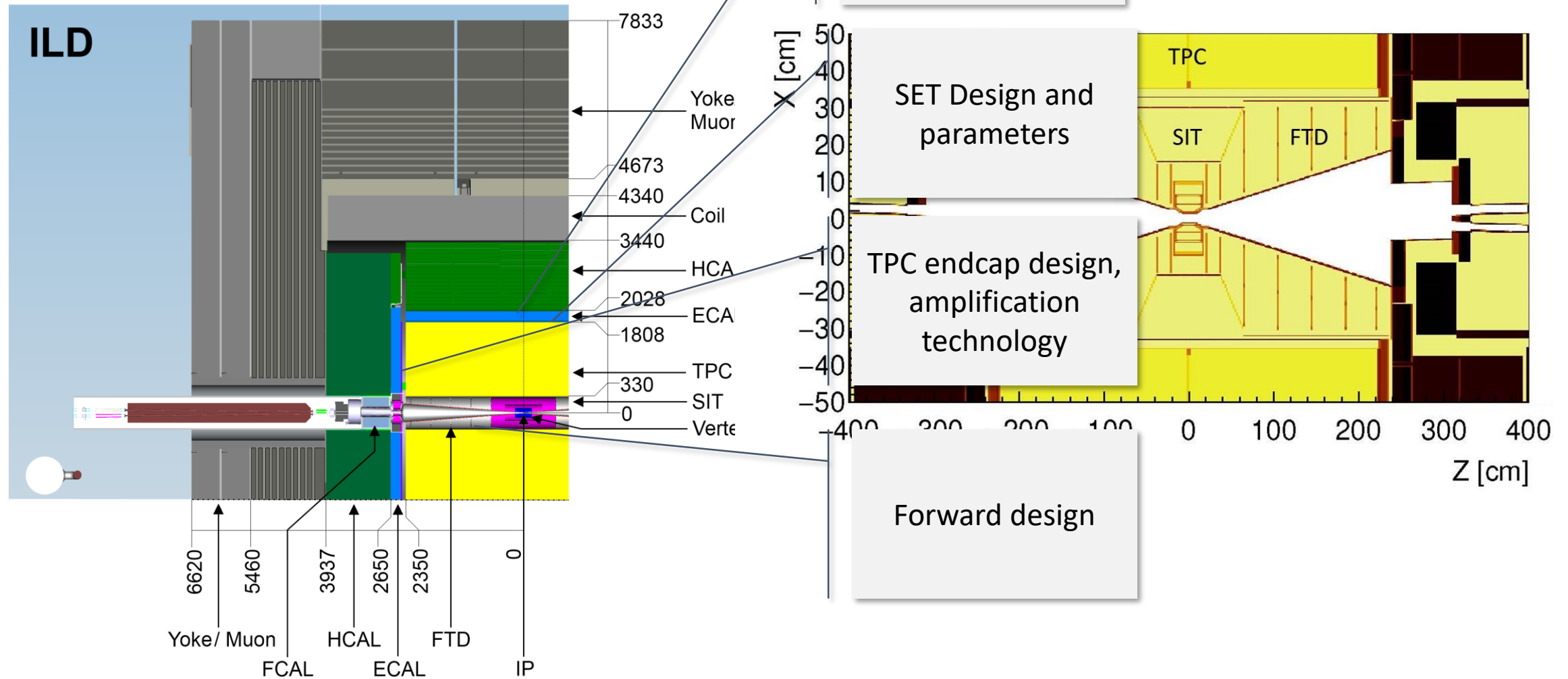

# Critical areas in ILD

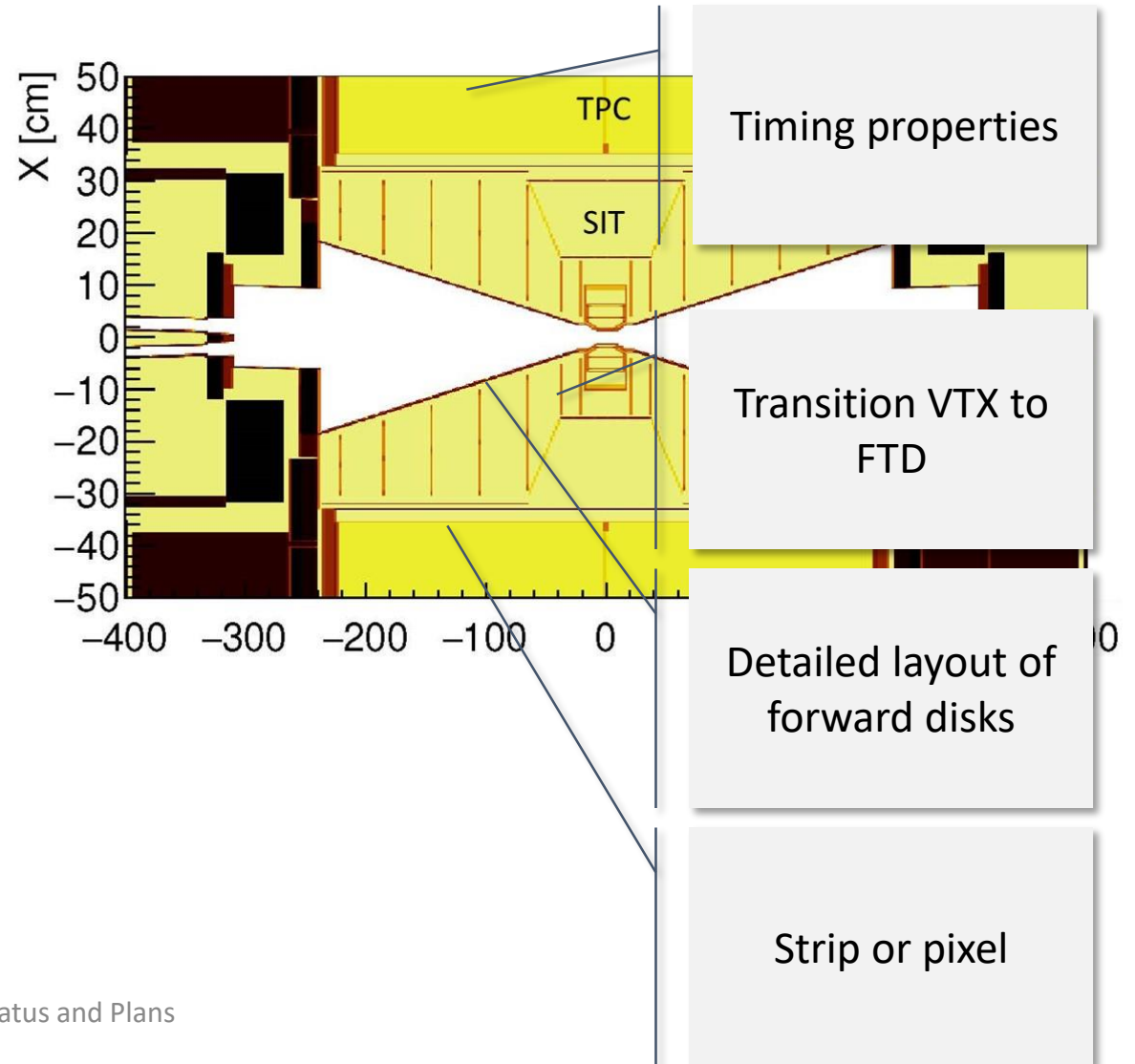
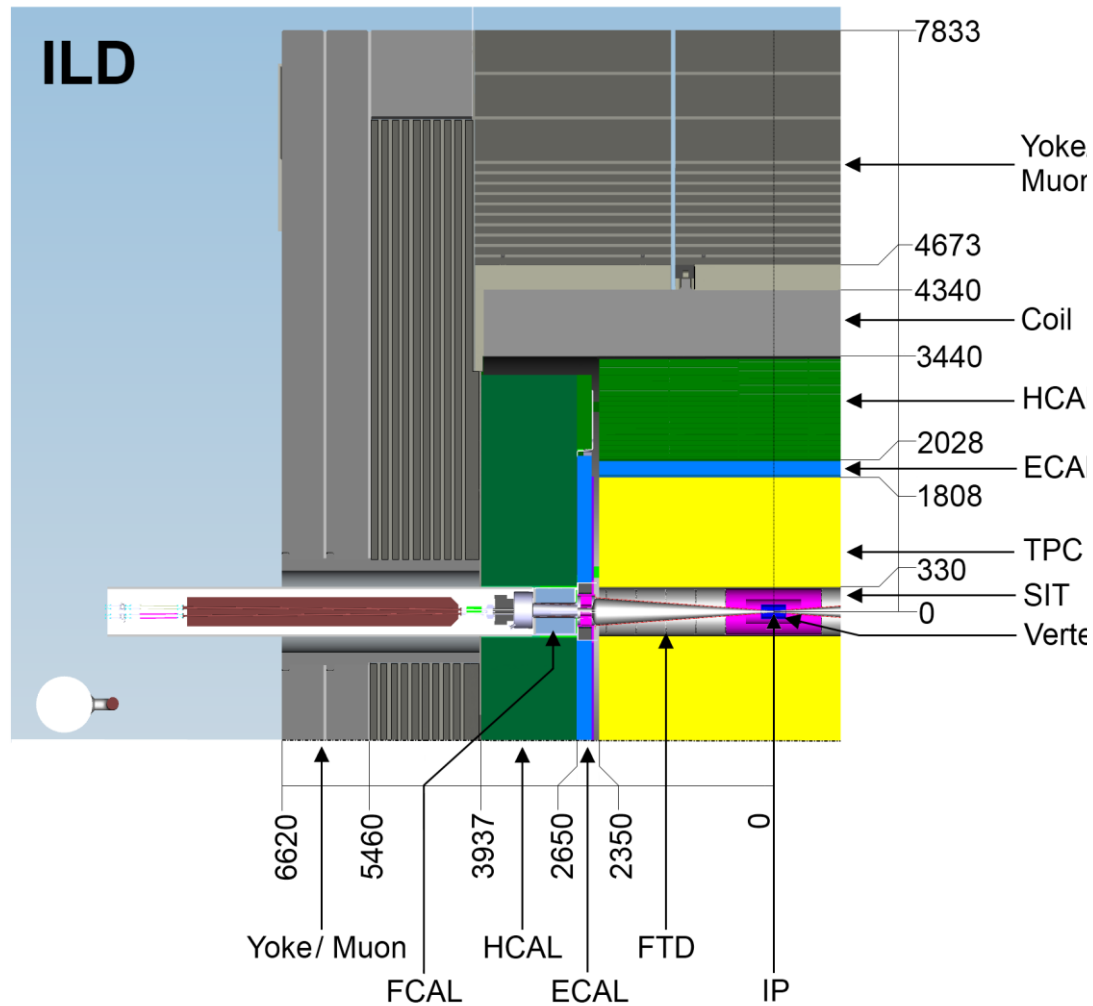

# Where are we?



## Calorimeter System

- Extensive prototyping done
- Extensive test beam campaigns
- Conceptual engineering

## Yoke/ Outer detectors

- Conceptual engineering done
- Detector concepts developed
- Coil concept under development

## Tracking

- TPC prototyping
- Silicon tracking conceptual studies
- VTX extensive technology studies

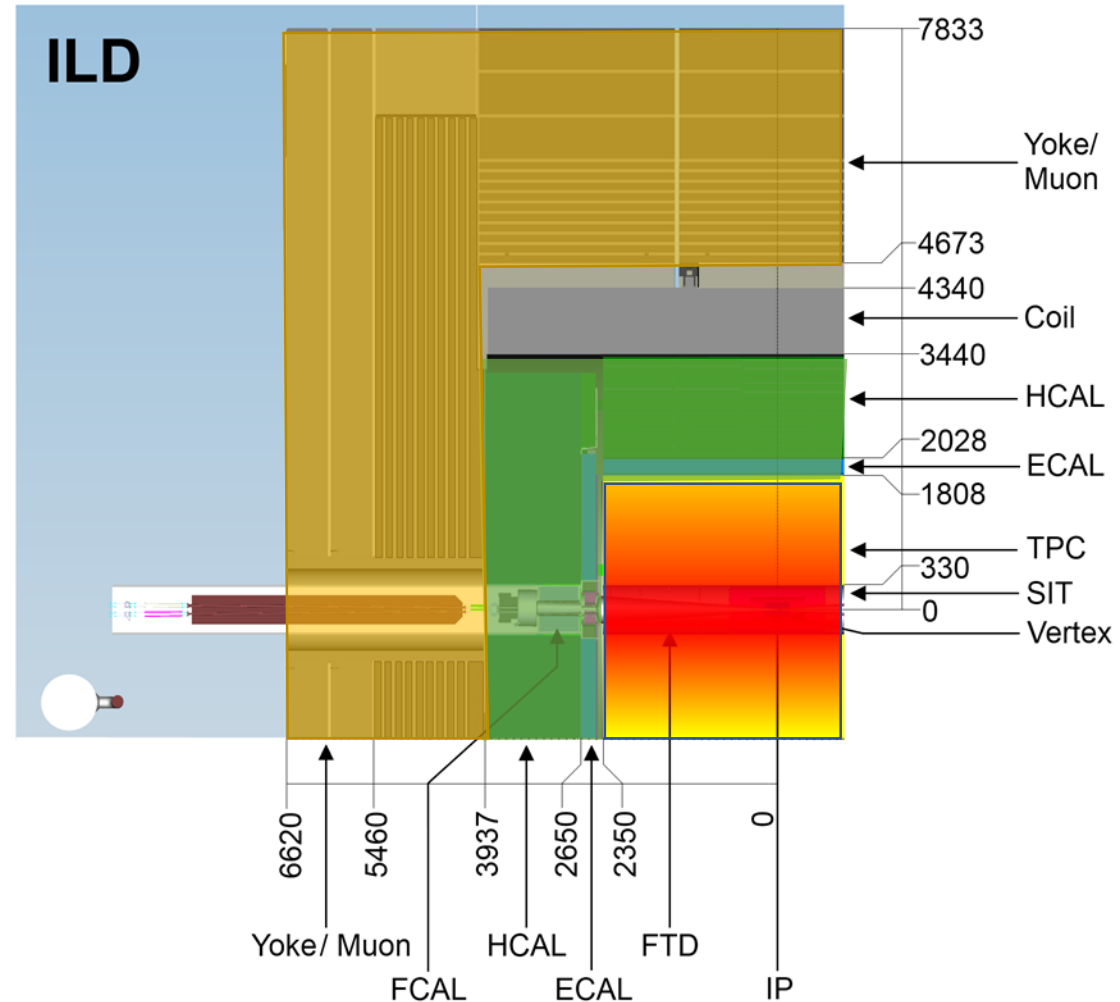

# New Developments: Timing as an example

Move the detector from 2D/ 3D to 4D/5D reconstruction

Timing at all levels

- Timing in tracking
- Timing in particle flow
- Timing in particle ID

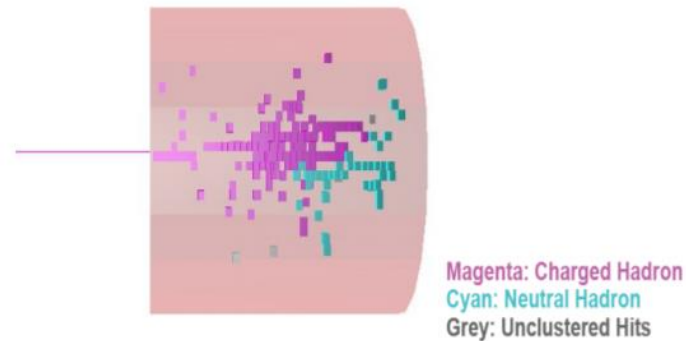

See talk by Marcel Vos  
in parallel session:

<https://indico.cern.ch/event/995633/contributions/4274687/>

3/17/2021

LCWS 2021 | ILD: Status and Plans

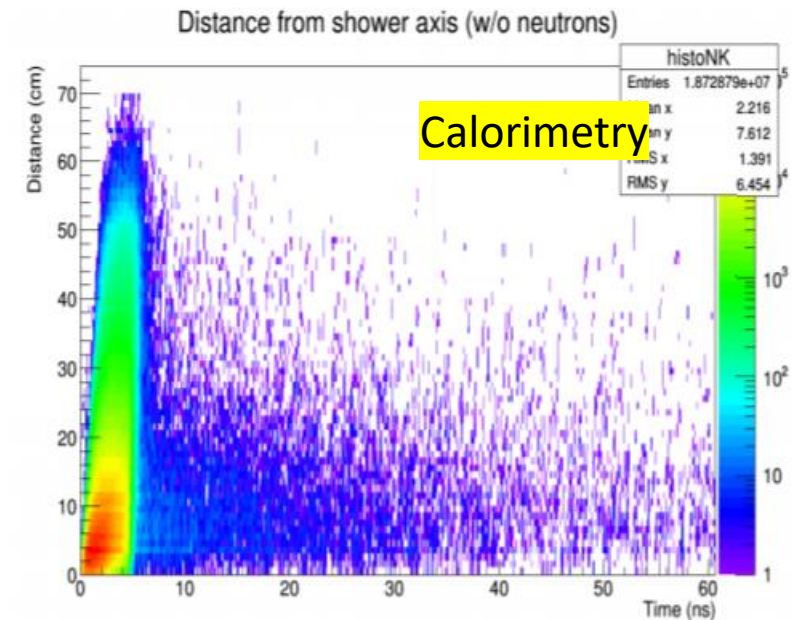
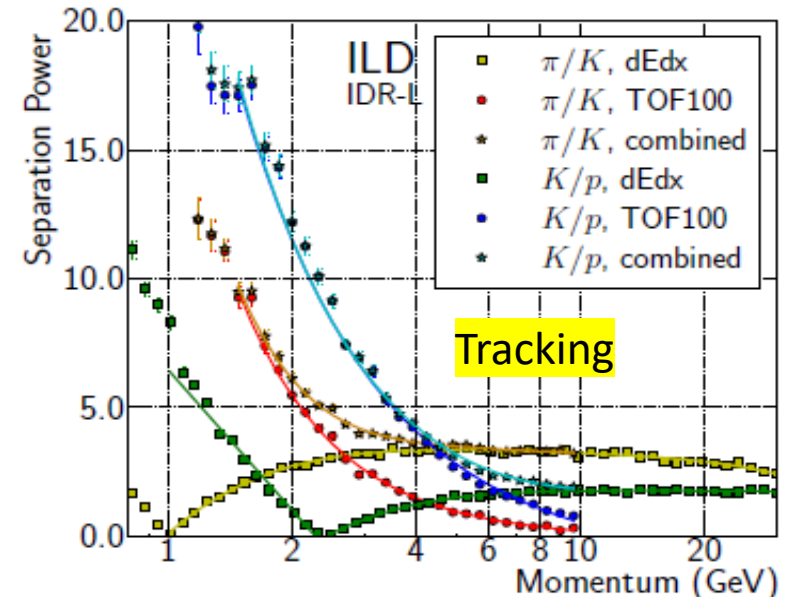

# Reality



Prototyping



Published: JINST 10 (2015) P10039



Demonstrating

Engineering

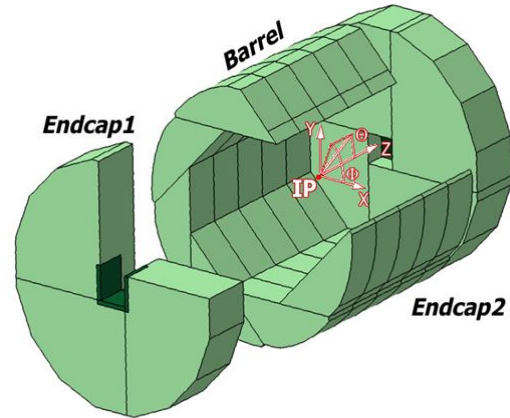

D: Model  
Total Deformation, 6.54 Hz  
Type: Total Deformation  
Frequency: 6.0905 Hz  
Unit: mm

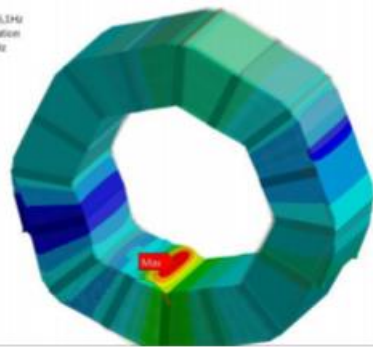
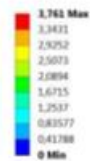

Integration

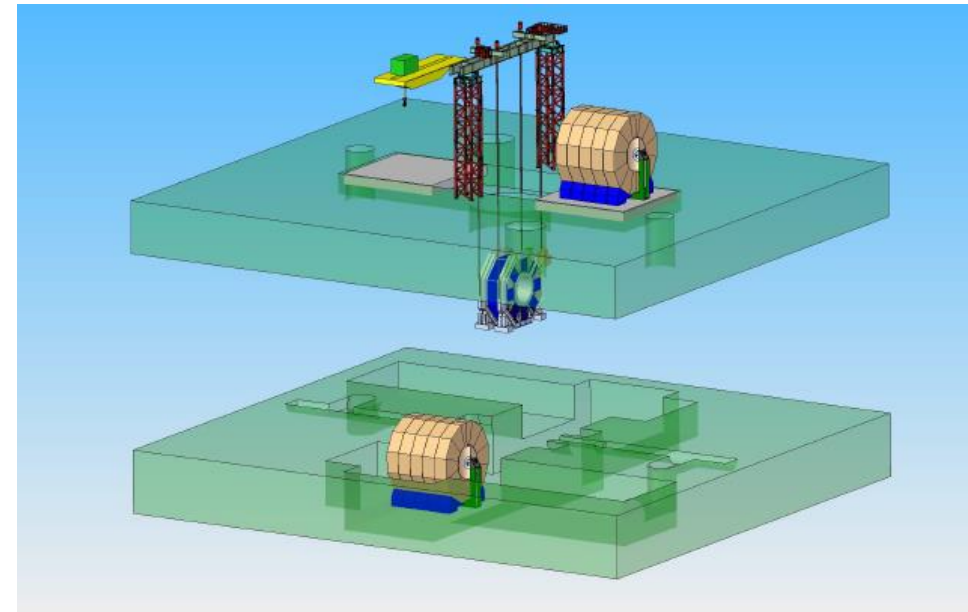

# Physics



Continued strong effort on analysis in the ILD context;

- Nearly all analyses done in full simulation
- Very active role by ILD in intn'l processes like snowmass, LCC, now IDT
- Comprehensive list of projects: [ILD collection of projects](#)

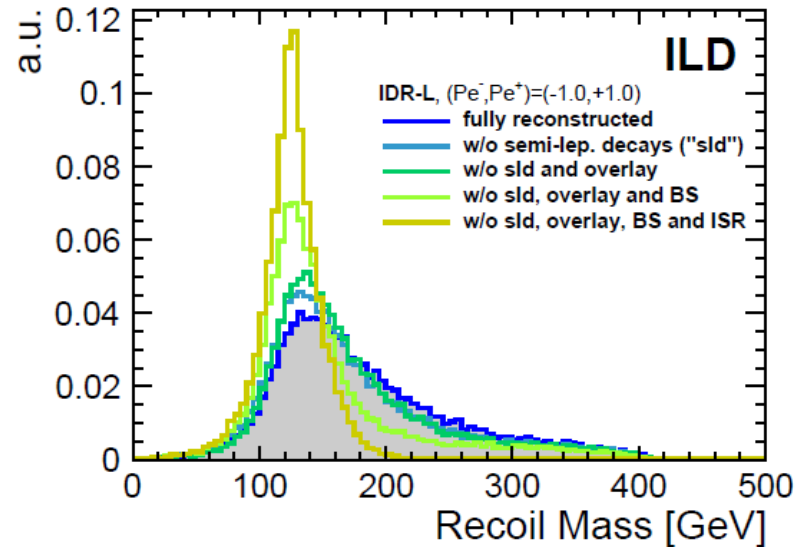

Recoil mass spectrum (invisible Higgs search) for different reconstruction conditions

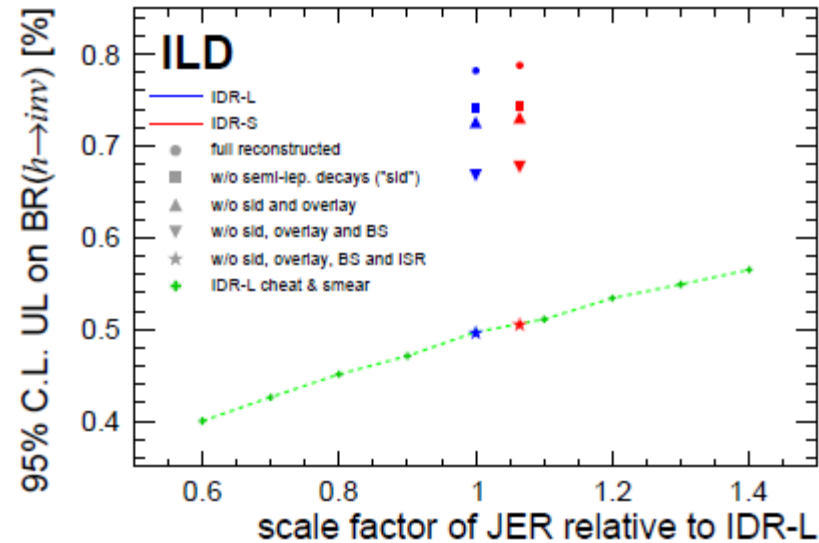

Impact of a detector indicator (JER resolution) on physics observable

# ILD and Software



ILD has done a lot on the software and reconstruction side:

- We are a central player in pushing community wide software solutions in particular with **iLCSoft** ( LCIO, DD4hep, etc) developed over 15 years
- We are reaching out to other communities (linear, circular, FCC-hh) to modernize our software stack: **key4hep** (DD4hep, EDM4hep,...)

There is enormous progress out there in the community on computing, computing models, computing implementations, analysis methods and tools:

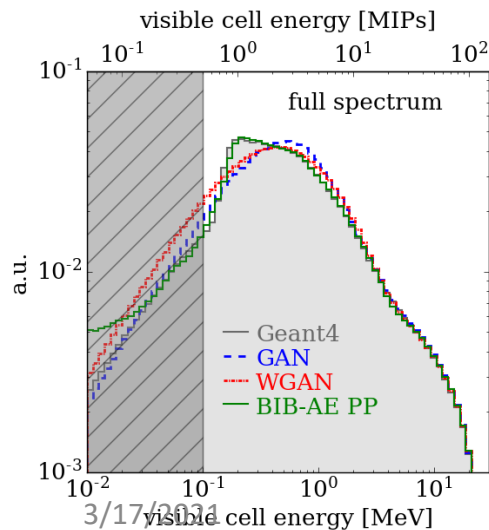

- parallelisation, multi-threading
- GPU based computing
- Machine Learning and AI
- Quantum computing

F. Gaede, E.Eren et al.:  
Use of GAN's to simulate  
photon showers in the ILD  
Calorimeter (2005.05334)

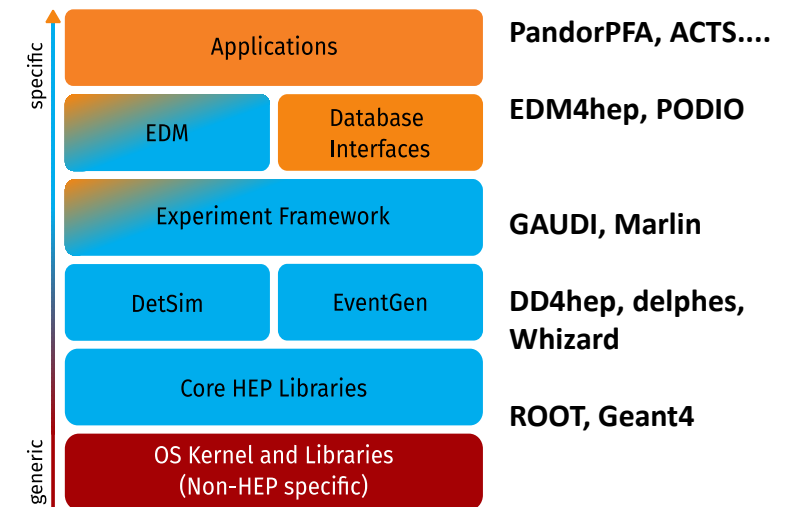
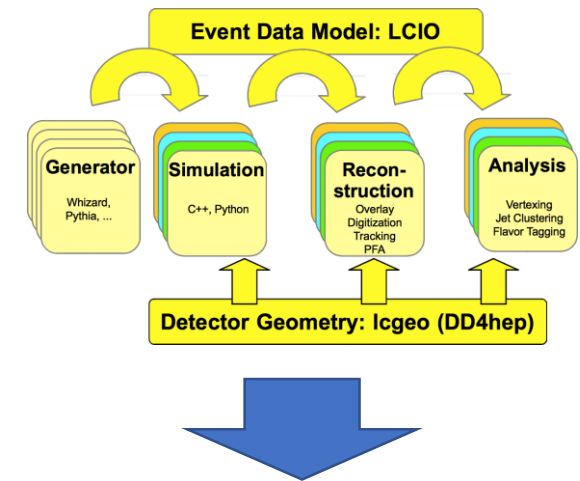

See also talk: *Software for future colliders: challenges and opportunities*, later this session

# Accessing ILD simulated data

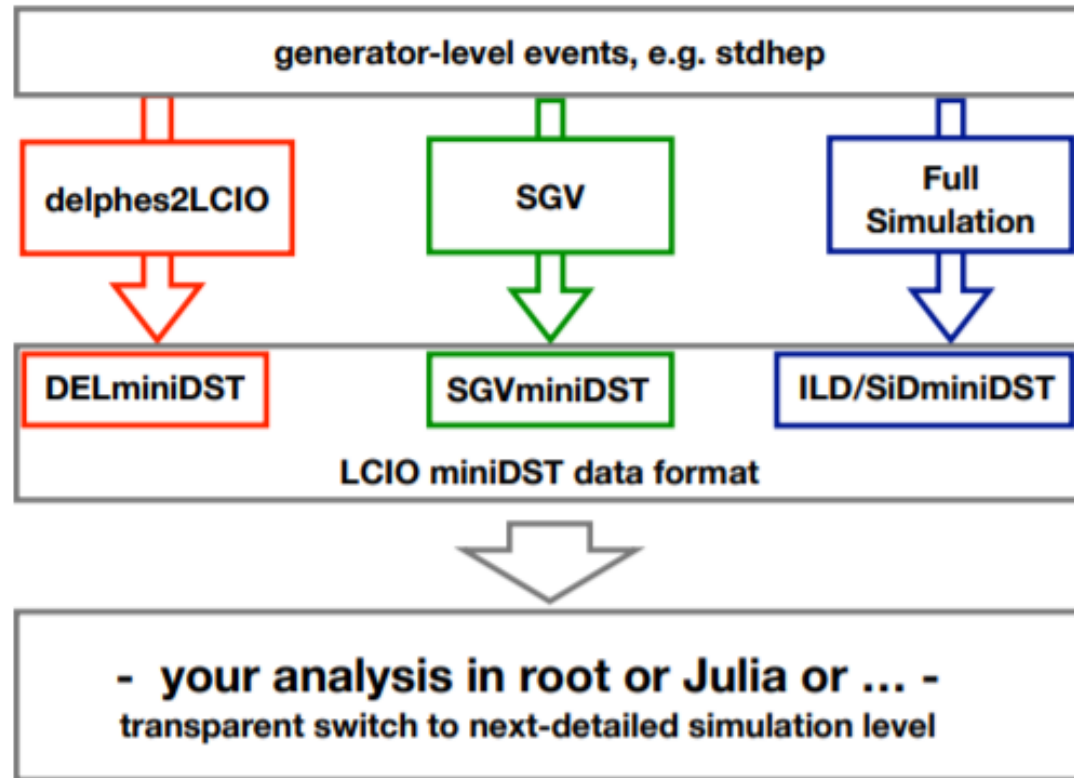

Fast simulation tool

- SGV fast simulation
- Delphes

Analysis based on DST stripped data sets

- Mini-DST files

Full simulation and analysis chain

- Full details
- Access to different technologies
- Full control over reconstruction
- Based on common standards like Lcio, DD4HEP, (key4hep)

# The next years



R&D oriented towards ILD: Formulate an ILD R&D plan

- What promising direction of R&D do we see to further improve ILD
  - Timing
  - Forward
  - ...
- Technology scouting: what new technologies do we see emerging which we can use to
  - Either make ILD better
  - Or make ILD cheaper

ILD is very well positioned:

- Application of our technologies: CMS Calo upgrade, Belle VTX, T2K TPC, ALICE TPC
- We have committed to concrete implementations where needed, we are open where sensible
- We have from very early on included overall integration and coherence in our discussions and work.

# Joining ILD



## We welcome new members

- No resource commitments needed
- Key contributions are possible in many areas
- Full participation in the shaping of the ILD program and future

## Guest membership

- Very simple access mechanism
- Access to ILD simulated data and tools
- Great to do a study or a feasibility study in the ILD context
- Limited duration

ILD

Frank Gaede posted on 10. Jun. 2016 13:41h - last edited by Ties Behrke on 13. Mar. 2021 09:48h

Welcome to the Wiki pages of the ILD detector concept group.

ILD is a detector concept proposed for the international linear collider, ILC.

You can find more general information on the ILD homepage at <http://www.ilcild.org>.

Search ILD pages:

Useful Links

- ILD meetings on indico
- Calendar with ILD meetings

Recent meetings  
see here for a list of meeting

News:  
Please join the upcoming LCWS 2021 conference online: <https://indico.cern.ch/event/995633/overview>

<https://confluence.desy.de/display/ILD/ILD>

<http://www.ilcild.org>

# Summary



ILD has been functioning well over the last years.

We are currently in the process to renew the ILD management

We have achieved a major milestone with the publication of the IDR

ILD has the ambition to be one of the major experimental programs at the ILC

We are committed to contribute to the IDT / prelab process in Japan

We are very open for new members and collaborators

3/17/2021

LCWS 2



ILD meeting at KEK, 2019

