



R&D on Flux Concentrator for positron sources

H. Bajas, Y. Zhao

Outline

- Flux Concentrator in linear accelerators
- Modelling of the geometry and the electrical circuit
- Validations of the model
- A tool for FC design optimisation
- Design optimization for the CLIC e+ source
- Update on manufacturing and testing
- Conclusion

Outline

- Flux Concentrator in linear accelerators
- Modelling of the geometry and the electrical circuit
- Validations of the model
- A tool for FC design optimisation
- Design optimization for the CLIC e+ source
- Update on manufacturing and testing
- Conclusion

Flux Concentrator in linear accelerators

Future linear colliders, such as CLIC at CERN, would use both electrons and **positrons**. The **positron source** produces positrons from the collision of electrons on fixed target then introduced in the pre-injector.

The quality of the source is of prior importance for the luminosity of the machine.

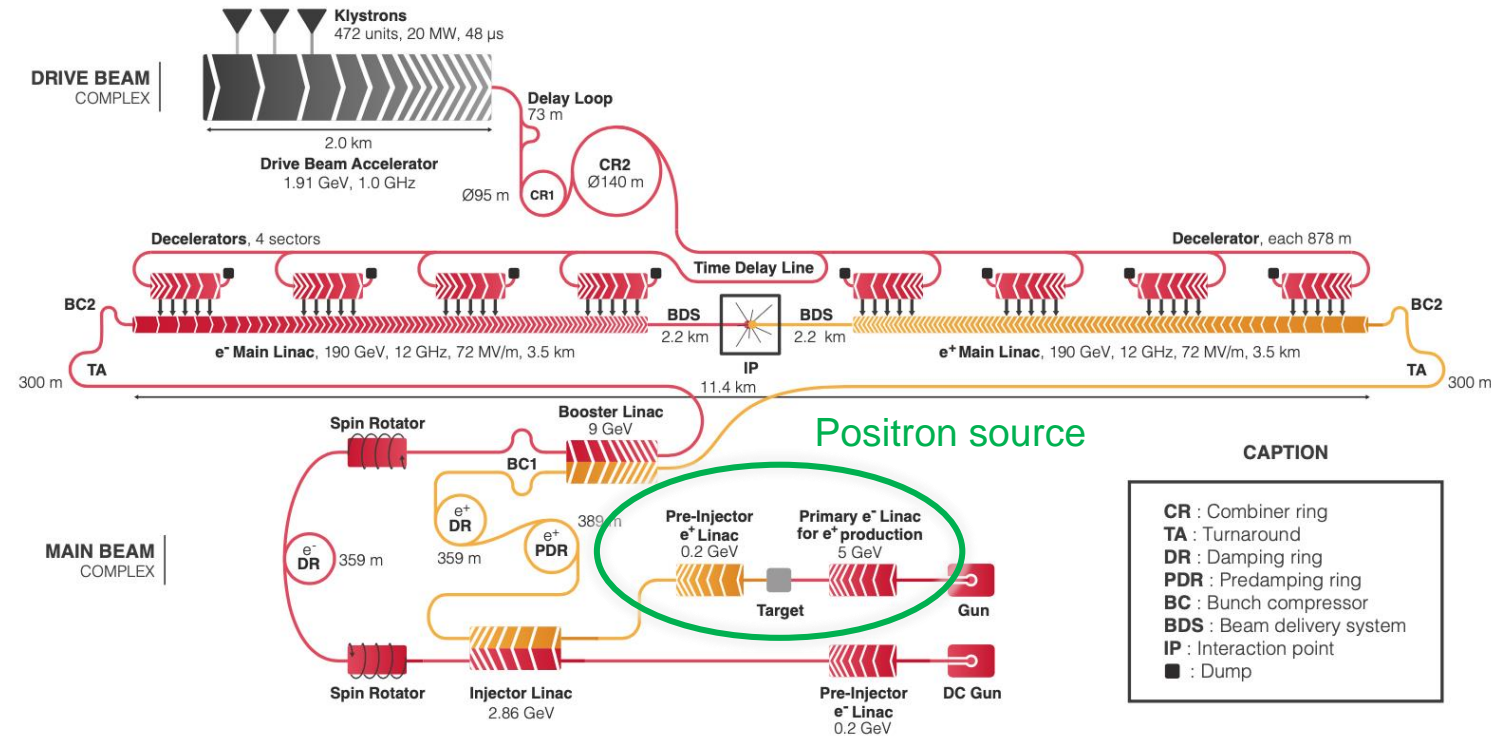
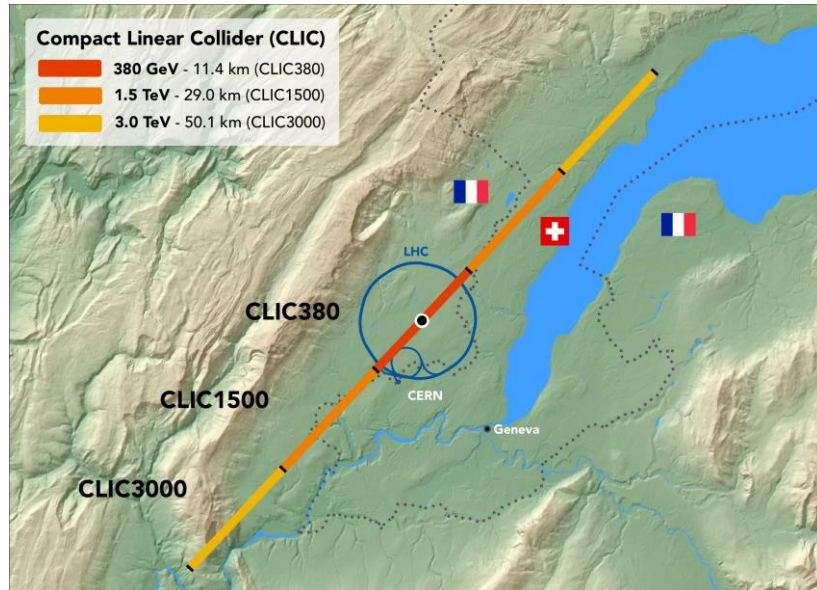

Steinar Stapnes, October 2019, Sendai
International Workshop on Future Linear Colliders



Outline

- Flux Concentrator in linear accelerators
- **Modelling of the geometry and the electrical circuit**
- Validations of the model
- Design proposal for the SuperKEKB e+ source
- Design optimization for the CLIC e+ source
- Update on manufacturing and testing
- Conclusion

Modelling of the geometry and the electrical circuit

Opera[®] allows linking the FE model to the circuit elements to impose flow of current (current supply, external resistor and winding elements)

Component Explorer

- Voltage
- Winding
 - W1
 - W2
 - W3
 - W4
 - W5
 - W6
 - W7
 - W8
 - W9
 - W10
 - W11
 - W12

Component Property

Winding: W6

Property	Value
Name	W6
Conductor Set	6
Circuit type	Bulk Eddy Current
Resistance per U...	#copper_resistivity
Unit	Ω/m
Turns per condu...	1
Use model symmetry	No
Symmetry Factor	1
Voltage Probe Resist...	1
Unit	MΩ
Initial current	0
Unit	A
Notes	
Show label	Name only
Font	A [MS Shell Dlg 2, 8]
Colour	[0, 128, 0] (255)
Show Direction	Yes

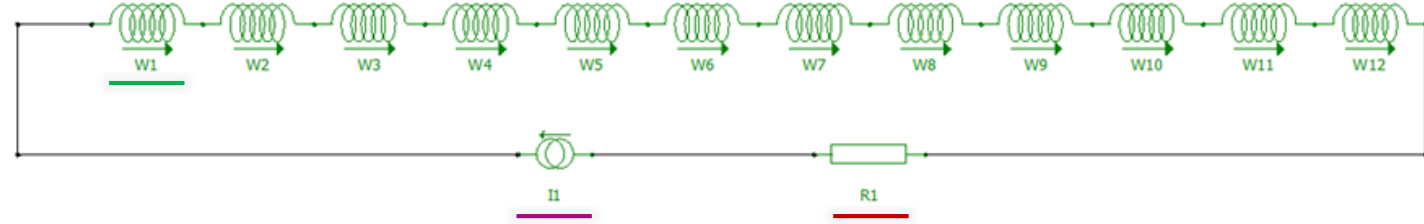
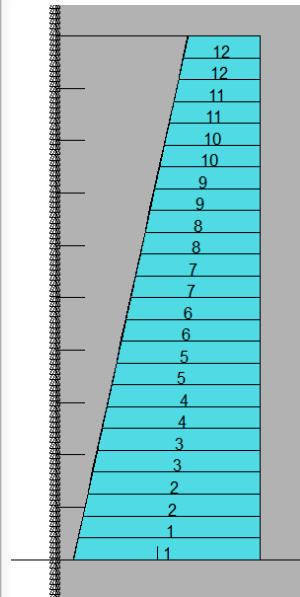

The built-in circuit allows reproducing the experimental pulse of current.

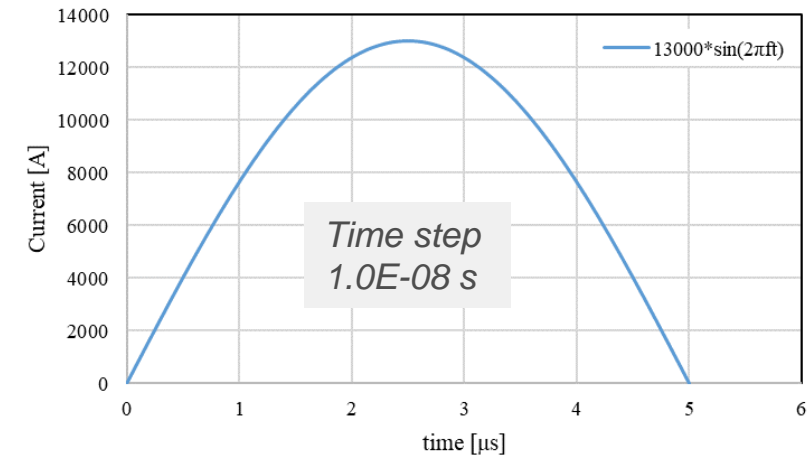
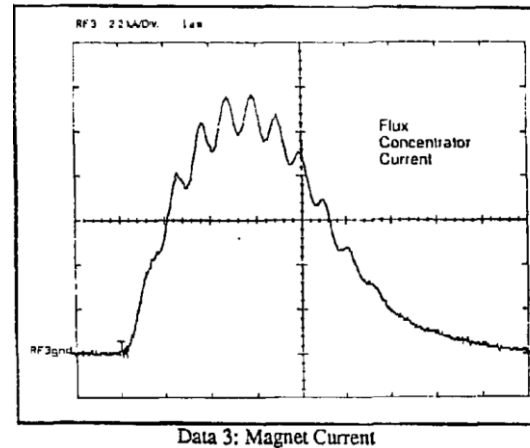

J. De Lamare, et Al. , "SLC Positron Source Flux Concentrator Modulator," SLAC-PUB-5472, May 1991.

Outline

- Flux Concentrator in linear accelerators
- Modelling of the geometry and the electrical circuit
- **Validations of the model**
- A tool for FC design optimisation
- Design optimization for the CLIC e+ source
- Update on manufacturing and testing
- Conclusion

Comparison with experimental result: SLAC

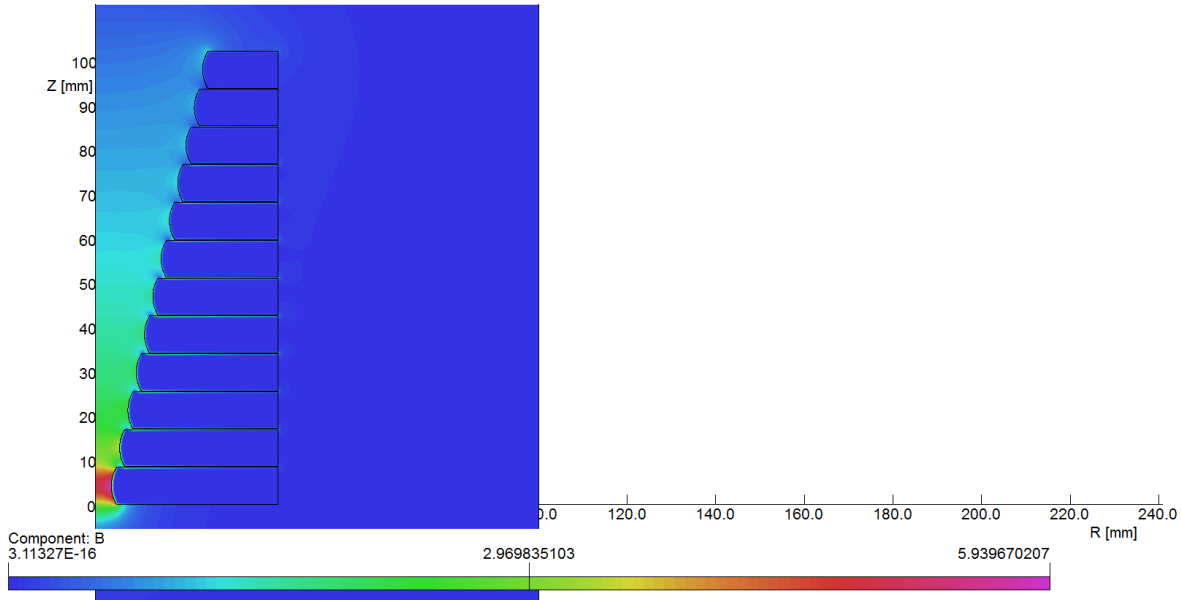

Solenoidal field map

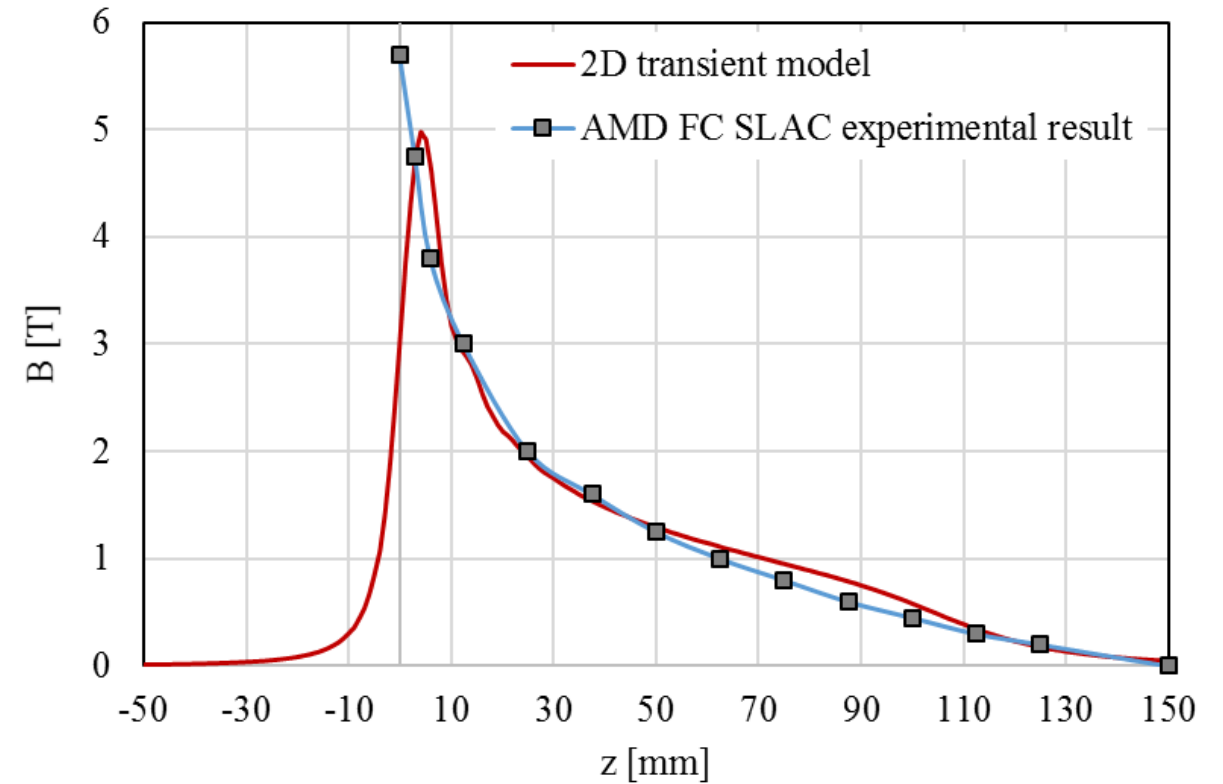

A.V. Kulikov, S.D. Ecklund, and E.M. Reute, "SLC Positron Source Pulsed Flux Concentrator," Stanford Linear Accelerator Center, Stanford University, Stanford, CA 94309, SLAC-PUB-5473, June 1991.

<https://agenda.linearcollider.org/event/8217/>

Comparison with experimental result : KEK

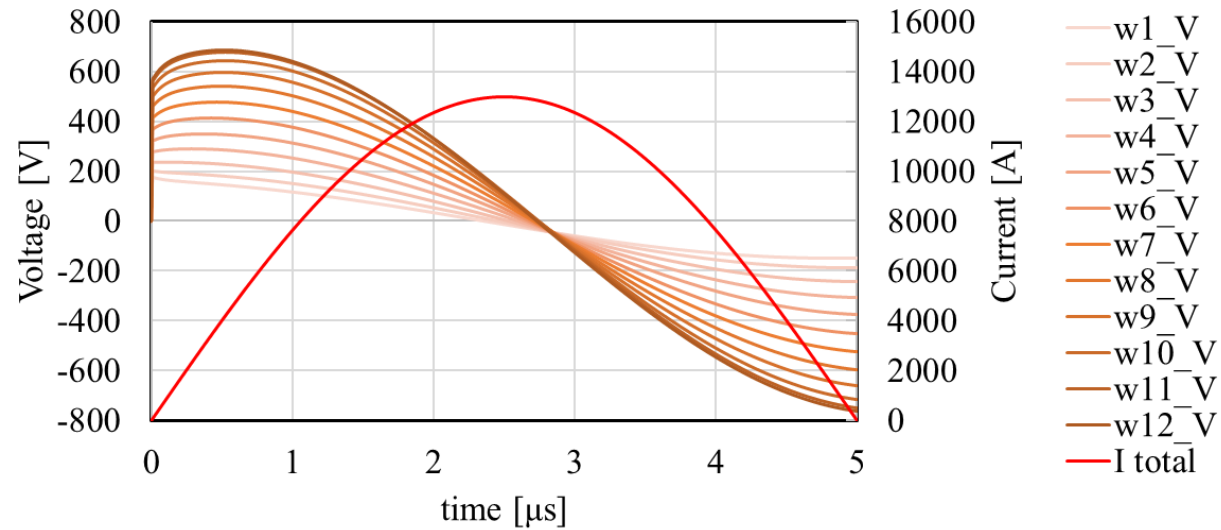

Voltage across each turn

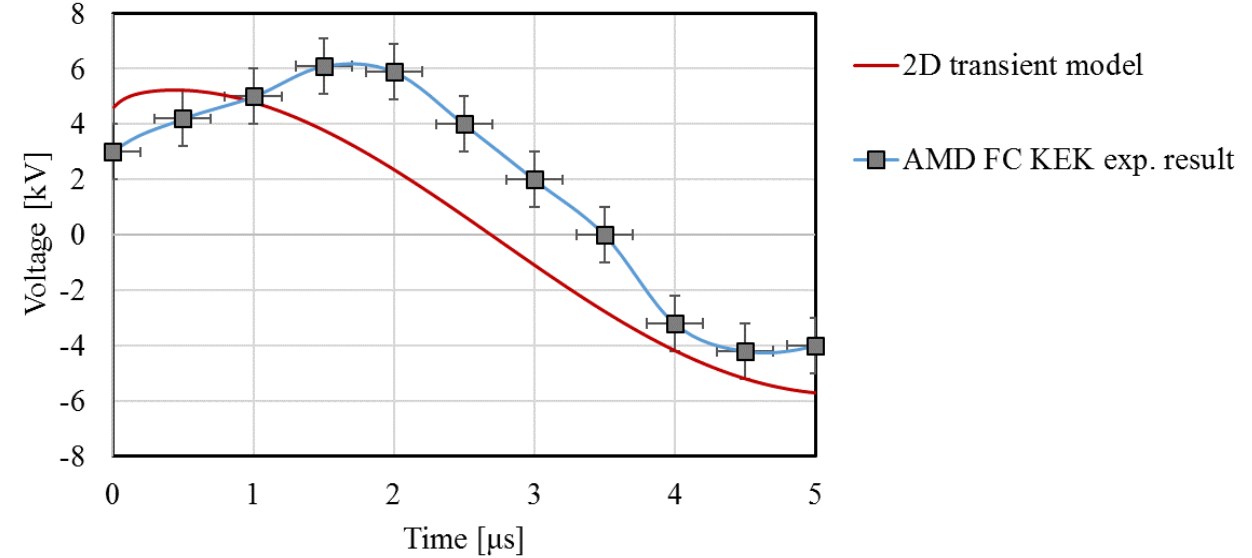

Voltage across the solenoid

See presentation of Yoshinori Enomoto

Outline

- Flux Concentrator in linear accelerators
- Modelling of the geometry and the electrical circuit
- Validations of the model
- **A tool for FC design optimisation**
- Design optimization for the CLIC e+ source
- Conclusion

A tool for FC design optimisation

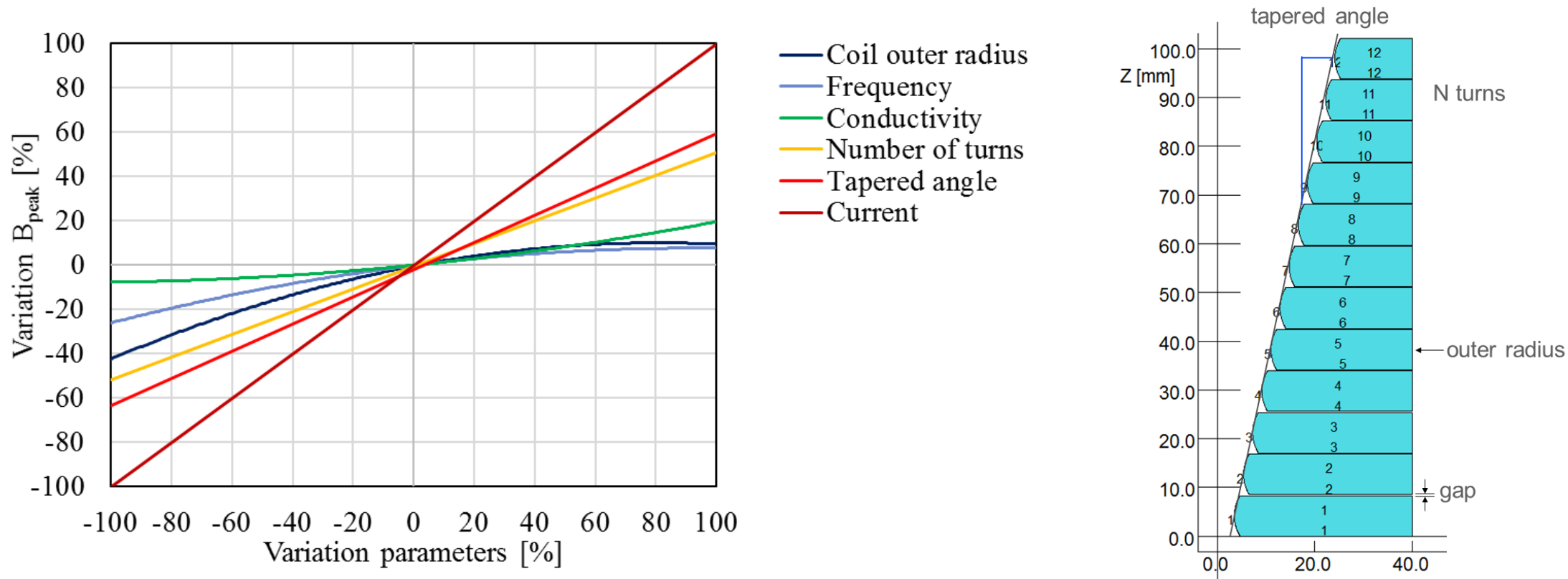

A **tool to optimise** FC's design.

In particular it is possible to **increase the gap between turns** compensating the loss of field.

<https://indico.cern.ch/event/879495/>

Dielectric breakdowns during the test of the KEKB FC

- Issue of **electrical arcing** between turns at full current discharge during FC test.

Flux Concentrator
design from KEK

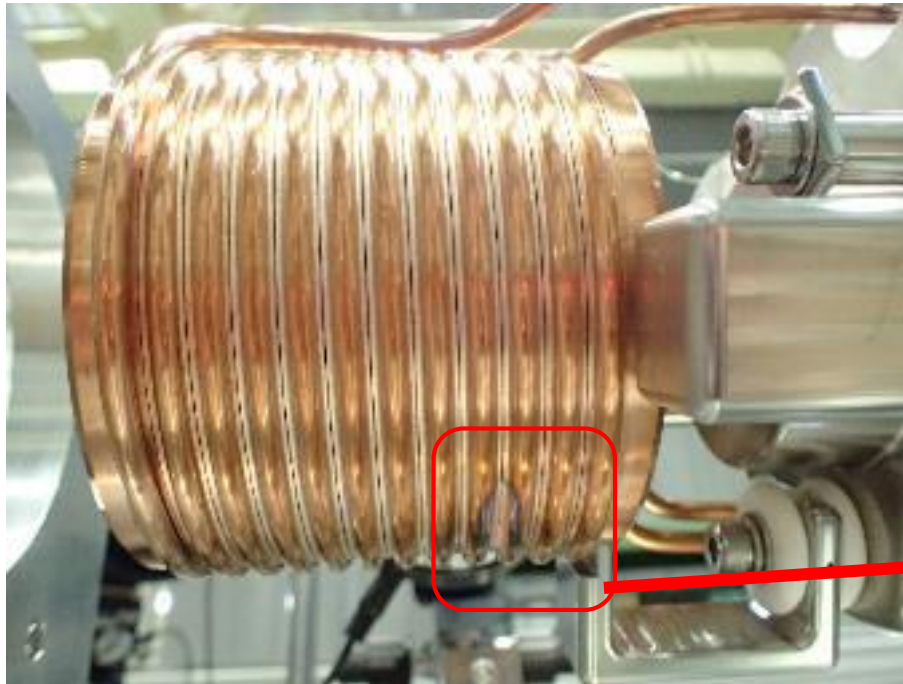

Courtesy Yoshinori Enomoto, October 2019, Sendai
International Workshop on Future Linear Colliders

Modified design to cope with breakdown issue

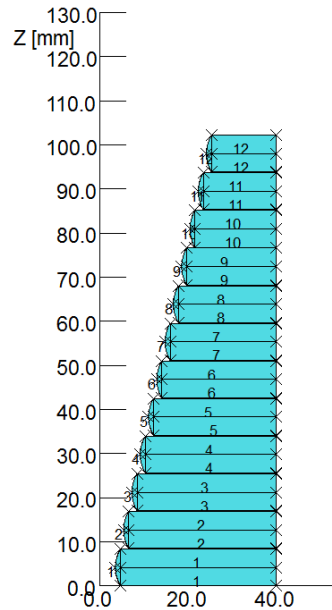

SLAC design

gap=0.2 mm

$\sigma=5.67 \cdot 10^7$ S/m

$R_o=40$ mm

N=12 turns

$\gamma=0.255$

f=100 kHz

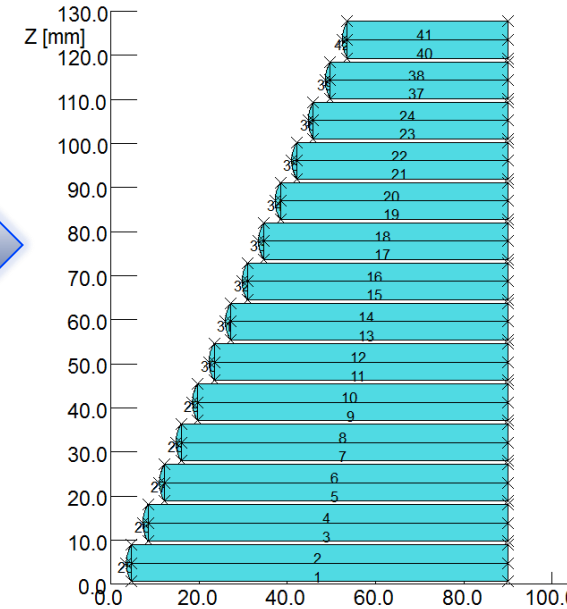

Modified design

gap=0.8 mm

$\sigma=5.67 \cdot 10^7$ S/m

$R_o=90$ mm

N=14 turns

$\gamma=0.450$

f=25 kHz

The **gap** between turns is increased and the loss of field compensated with **2 extra turns** and larger **tapered angle**.

The voltage between turns is minimized using lower frequency and larger outer radius.

<https://indico.cern.ch/event/879495/>

Expected results for the modified design

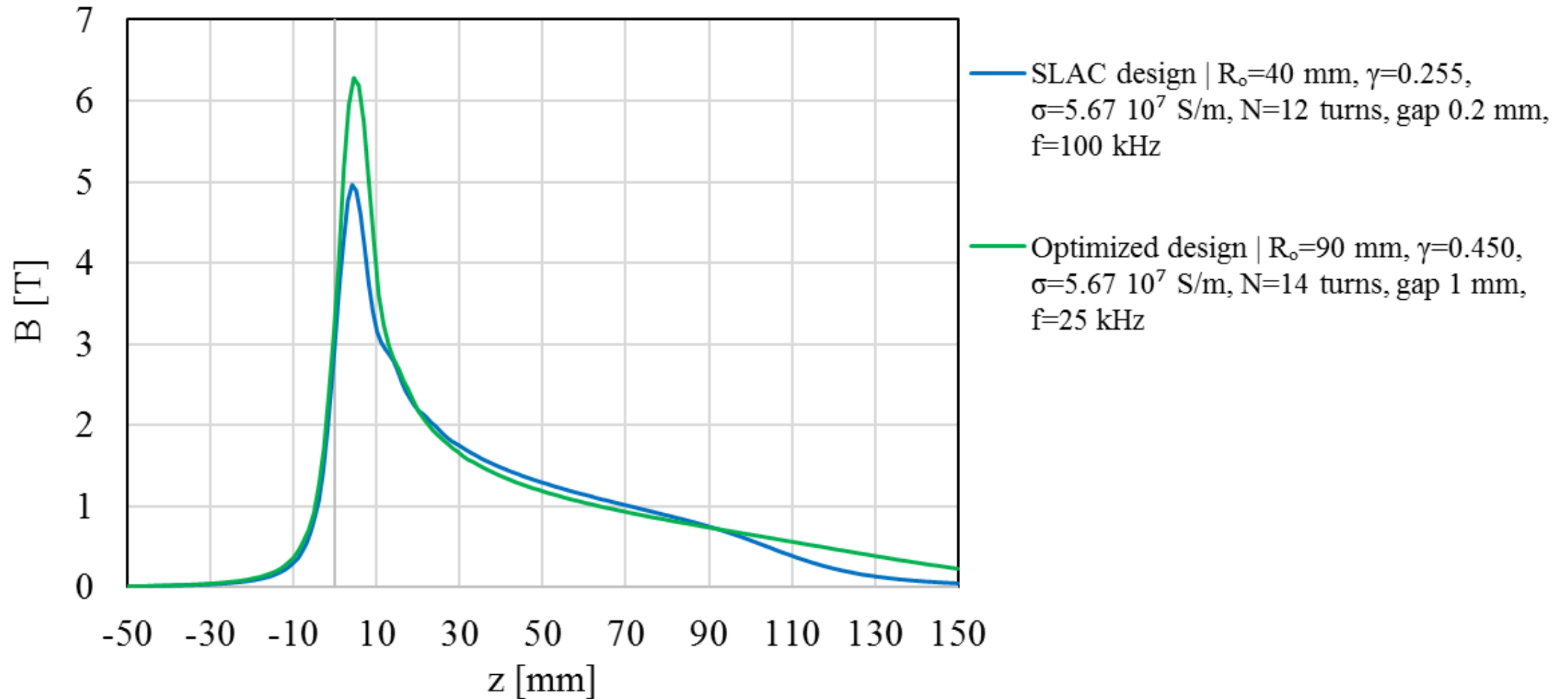

Outline

- Flux Concentrator in linear accelerators
- Modelling of the geometry and the electrical circuit
- Validations of the model
- A tool for FC design optimisation
- **Design optimization for the CLIC e+ source**
- Update on manufacturing and testing
- Conclusion

Design optimization for the CLIC e+ source

- Parameters to optimize:
 - To maximize:
 - the *positron yield* (purpose of the device)
 - To minimize:
 - the *total voltage* & the *inter-turn voltage* (power supply limitation & electrical breakdown)
 - the Lorentz forces (mechanical displacement, vibration)

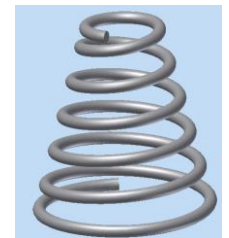
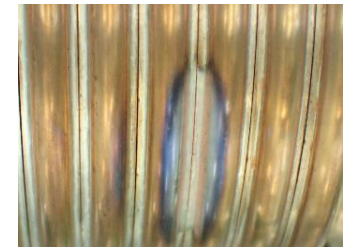
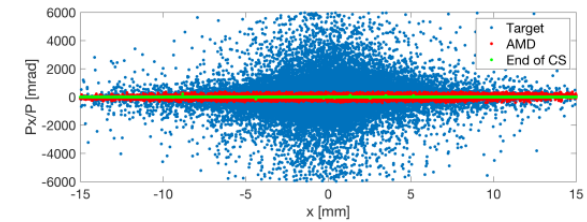

Design optimization for the CLIC e+ source

- OPERA computes: the field, the voltages and the Lorentz forces.
- The positron yield is computed using RF-track and GEANT4 by Yongke Zhao (many thanks!).

<https://indico.cern.ch/event/862915/>

A. Latina, “RF-Track: Beam Tracking in Field Maps Including Space-Charge Effects, Features and Benchmarks”, 2017.
<https://geant4.web.cern.ch/>

Design optimization for the CLIC e+ source

SLAC design
@ 25 kHz & 13 kA

Graphics containing the parameters to optimize.

Use of the radar plot to compare different design of FC.

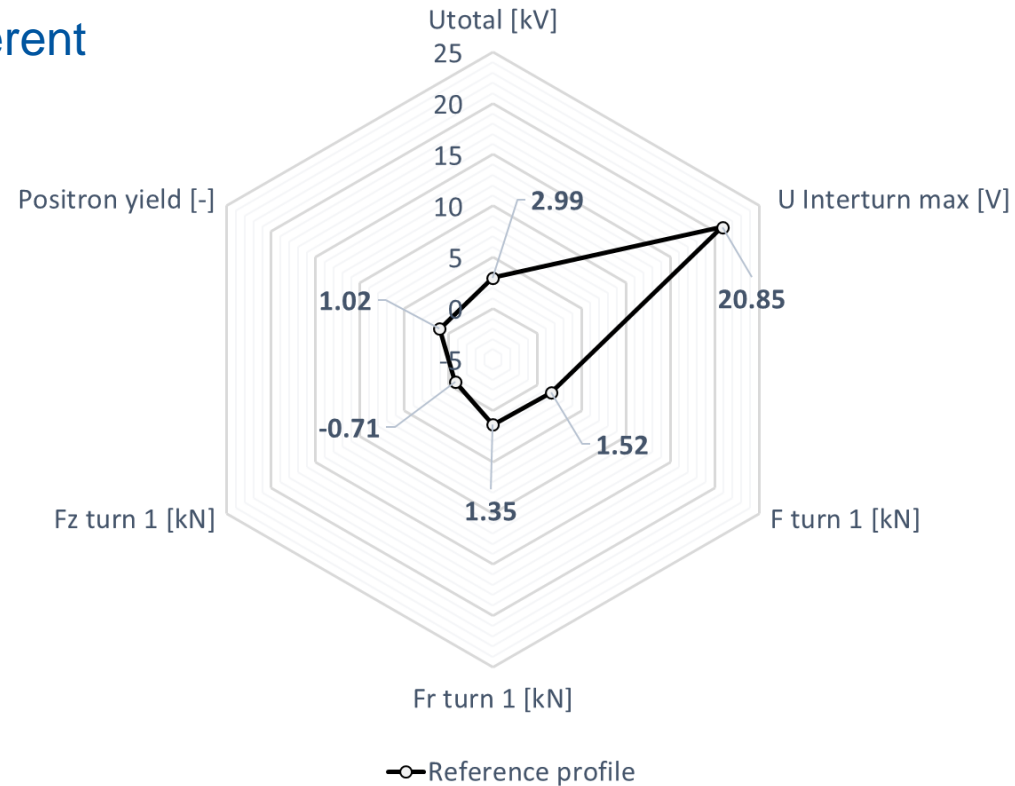

Design optimization for the CLIC e+ source

SLAC design (reference)
@ 25 kHz & 13 kA

Vs.

linear modified design
@ 25 kHz & 13.8 kA

The modified design induces a significant increase of each parameters' value:

- The yield increases by 23%
- The voltage increases by 92% (due to the gap increase and current increase)
- The forces get ~3 times higher

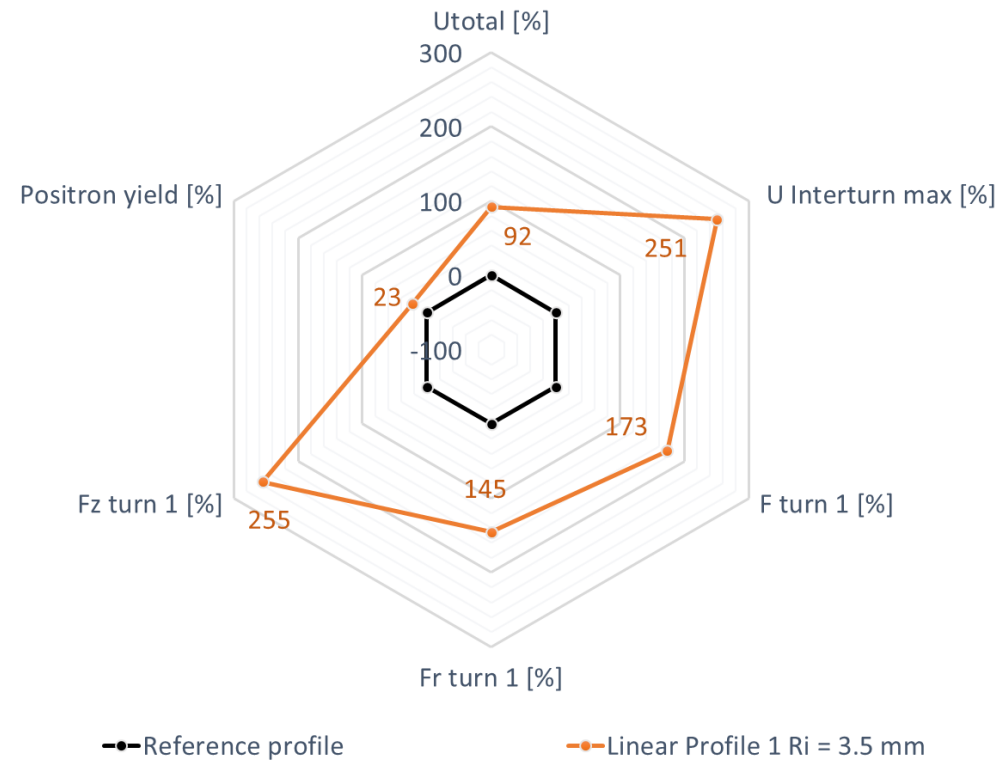

Design optimization for the CLIC e+ source

SLAC design
@ 25 kHz & 13 kA

Vs.

linear modified design

Vs.

linear modified design
with large aperture

- Increasing the aperture (from 3.5 to 6.5 mm) **increases the yield by 104%** (from 1.25 to 2.08).

- But... both voltages and Lorentz forces grow very fast!

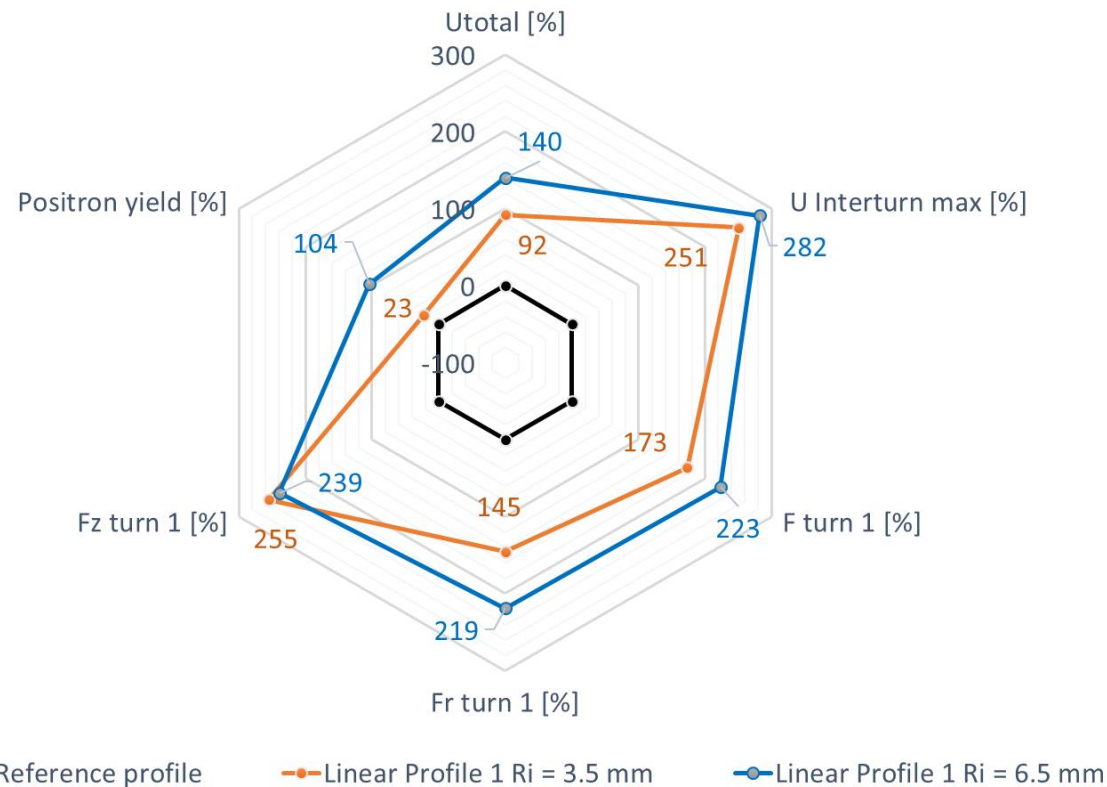

How can one lower down the other parameters keeping high yield?

Design optimization for the CLIC e+ source

- From linear to non-linear profile for the FC aperture:

Linear

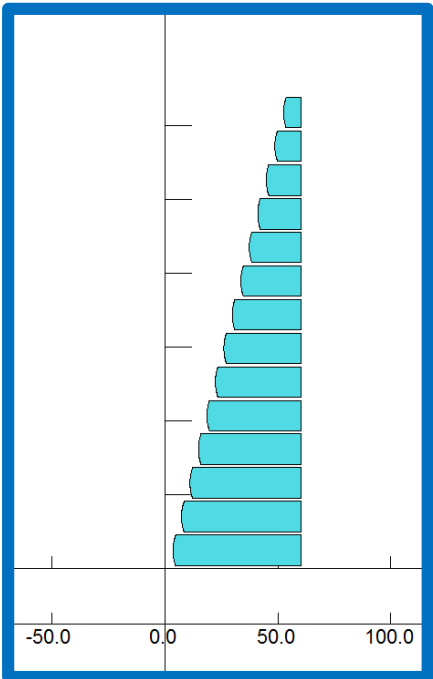

Concave downward (1)

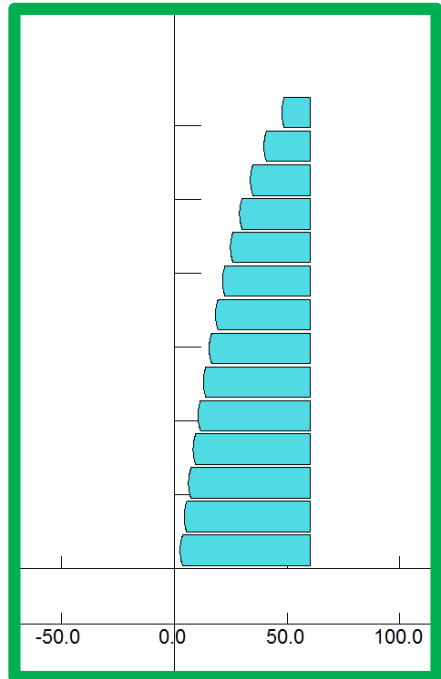

Concave downward (2)

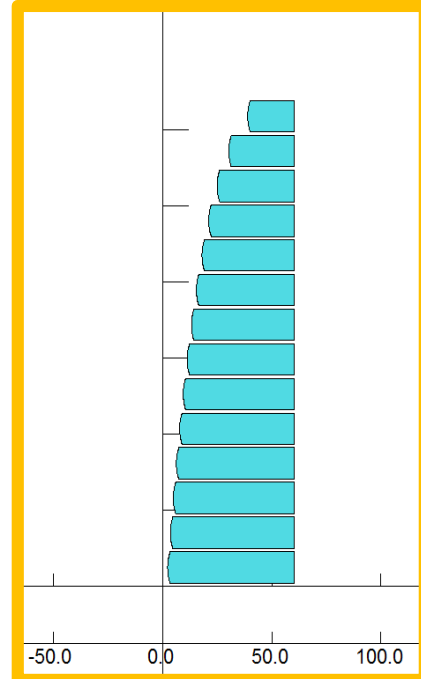

Concave downward + linear (3)

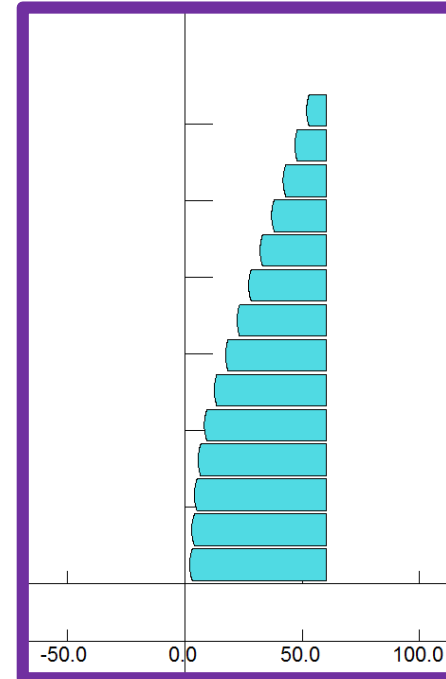

Concave upward

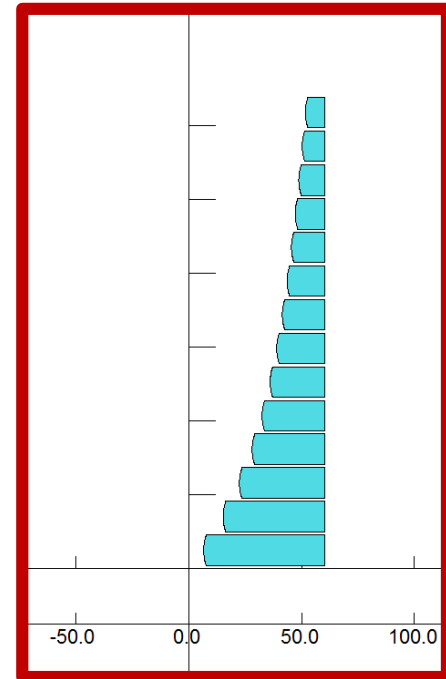

How does the shape impact the parameters to optimize?

Design optimization for the CLIC e+ source

SLAC design
@ 25 kHz & 13 kA

Vs.

**linear modified design
with large aperture**

Vs.

**Non-linear design (1)
Concave downward**

- The use of non-linear shape induces a dramatic drop of the voltages.
- The Lorentz forces decrease significantly.
- The yield get lower but is still 56% higher than the reference case.

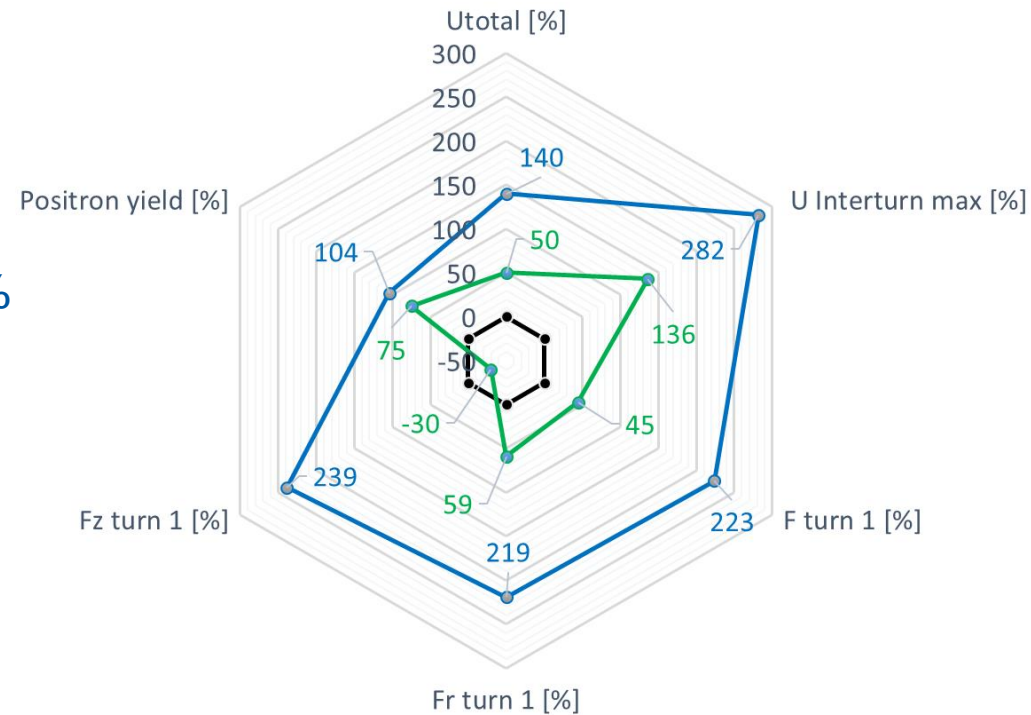

—●— Reference profile
 —●— Linear Profile 1 Ri = 6.5 mm
 —●— Inv. Exp. Profile 1 Ri = 6.5 mm

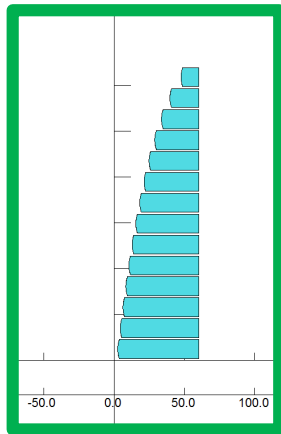

Design optimization for the CLIC e+ source

- Using more exotic shape allows to decrease the Lorentz forces.
- The yield gets slightly lower though.
- The voltage gets higher.

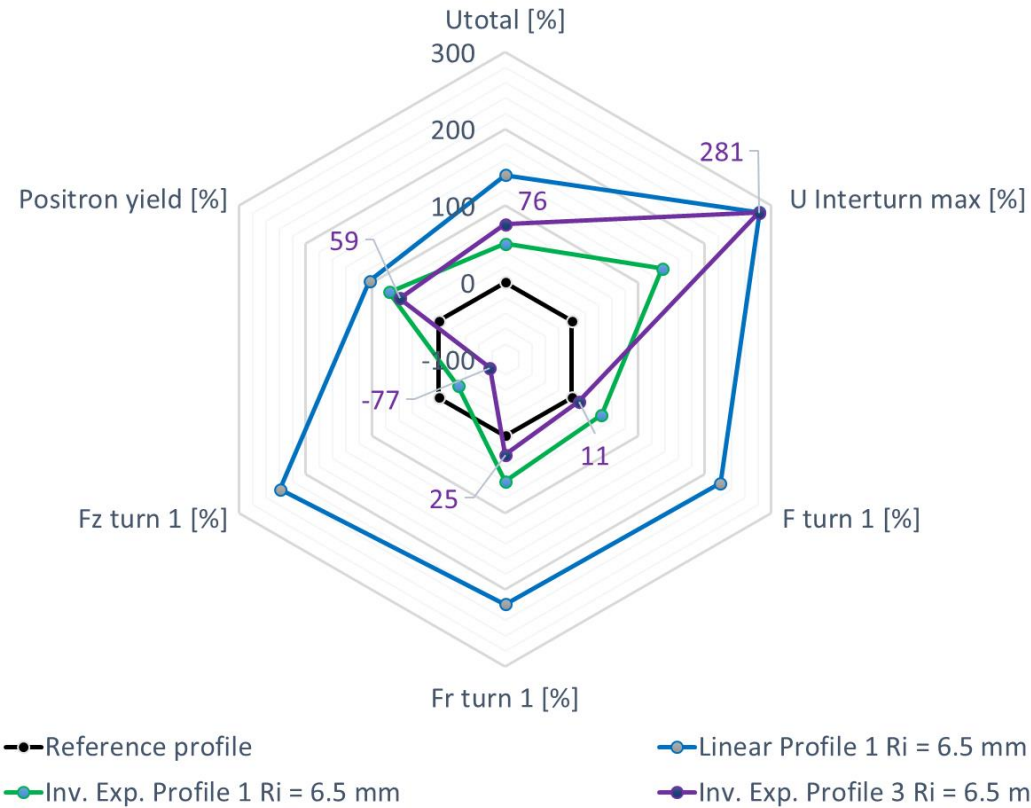
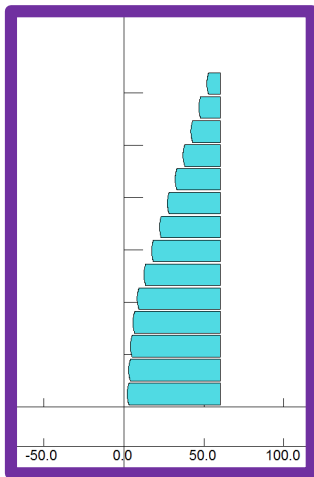

SLAC design
@ 25 kHz & 13 kA

Vs.

**linear modified design
with large aperture**

Vs.

**Non-linear design (1)
Concave downward**

Vs.

**Non-linear design (3)
Concave downward + linear**

Design optimization for the CLIC e+ source

- Adapting the non-linear shape (**green vs. yellow**) preserves the yield (53% higher).
- The voltages get significantly lower.
- The detrimental forces directed along the coil axis Z lowers too.

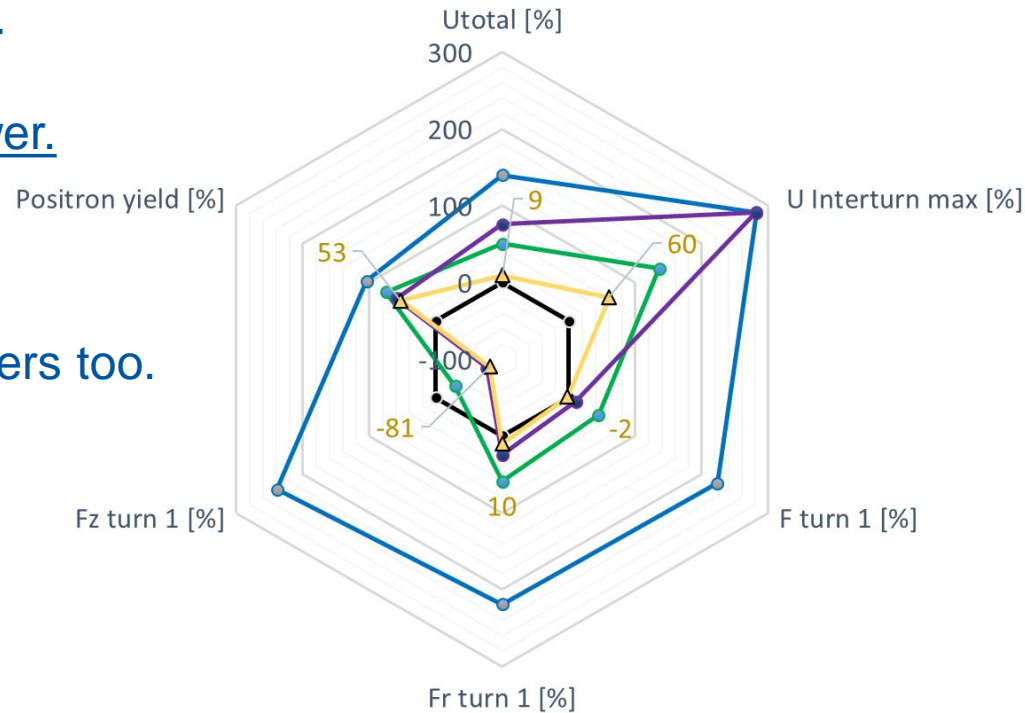
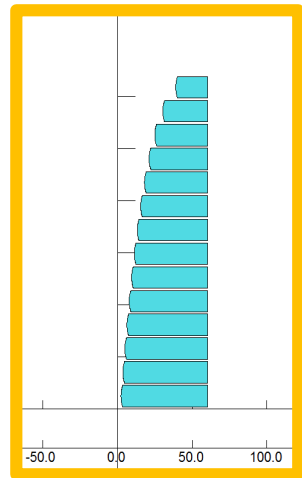

-●- Reference profile
 -●- Linear Profile 1 Ri = 6.5 mm
 -●- Inv. Exp. Profile 1 Ri = 6.5 mm
 -●- Inv. Exp. Profile 3 Ri = 6.5 mm
 -▲- Inv. Exp. Profile 2 Ri = 6.5 mm

SLAC design
@ 25 kHz & 13 kA

Vs.

**linear modified design
with large aperture**

Vs.

**Non-linear design (1)
Concave downward**

Vs.

**Non-linear design (3)
Concave downward + linear**

Vs.

**Non-linear design (2)
Concave downward**

Design optimization for the CLIC e+ source

- The upward concavity gives the second highest yield with 81 % increase.
- Voltages and forces are much higher than the linear case.

Adding the upward concavity case

Mind the change of scale !!

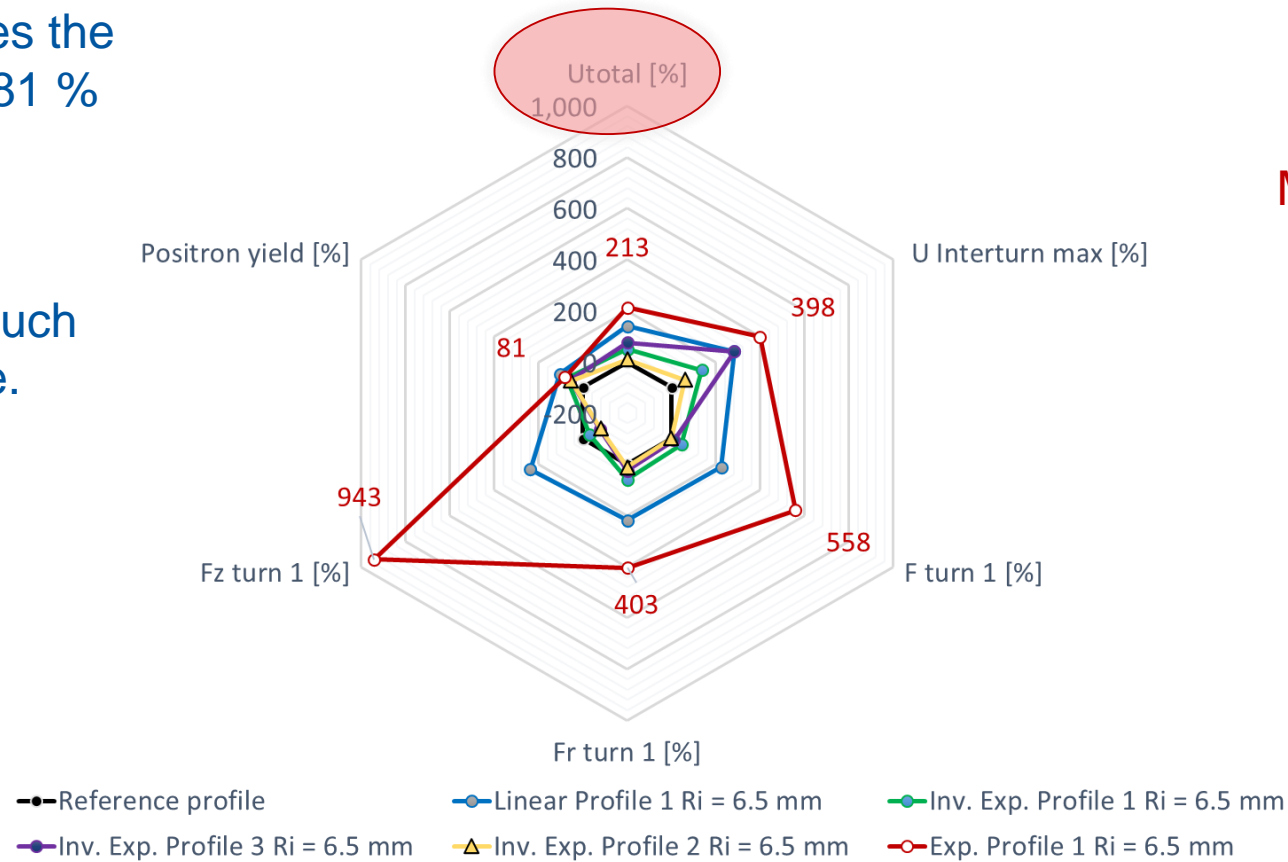
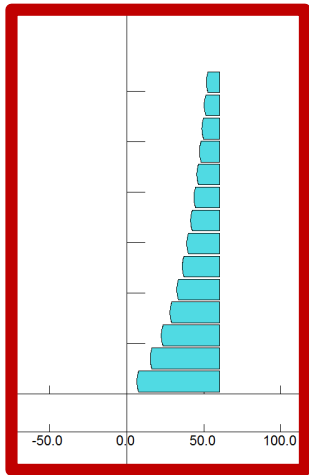

Outline

- Flux Concentrator in linear accelerators
- Modelling of the geometry and the electrical circuit
- Validations of the model
- A tool for FC design optimisation
- Design optimization for the CLIC e+ source
- **Update on manufacturing and testing**
- Conclusion

Update on manufacturing and testing

Production of technical drawing with the CERN design office (EN-MME)

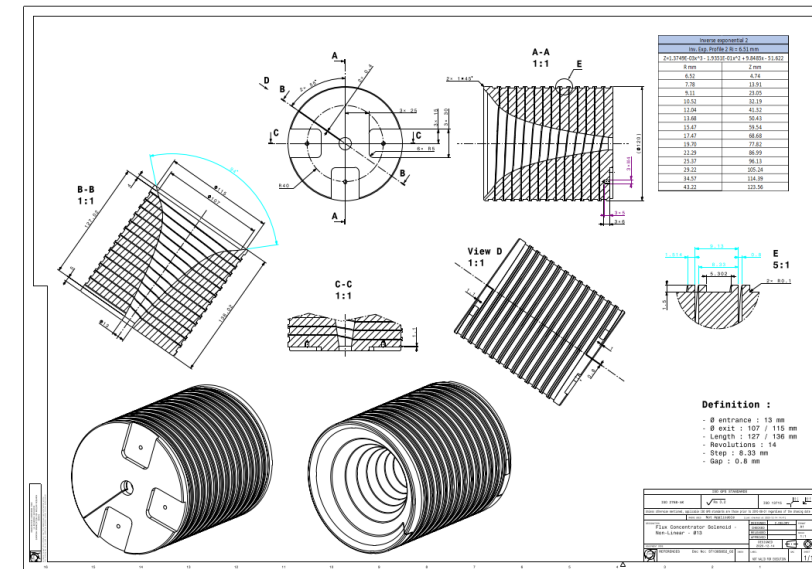
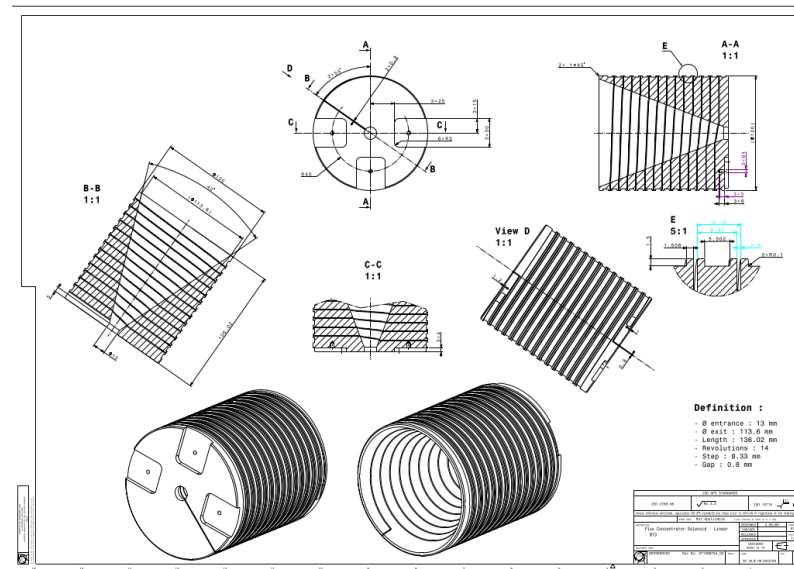
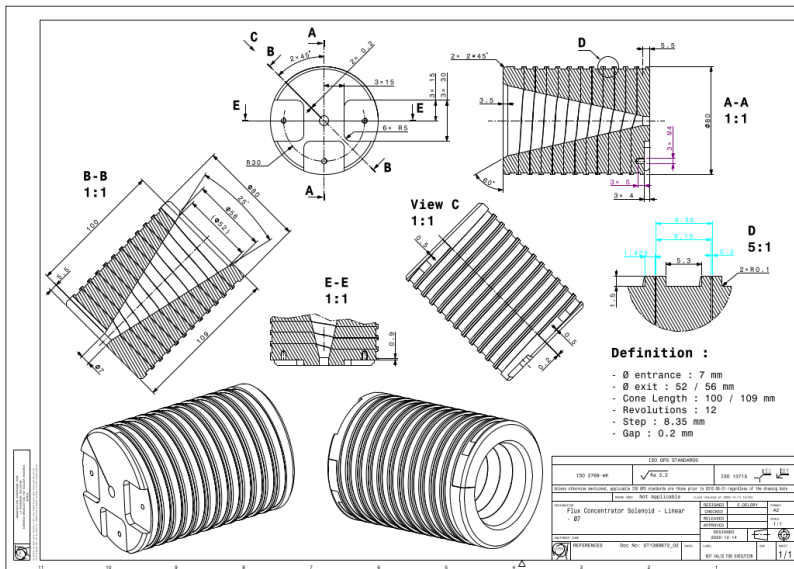

Goal: test and validate the various features studied by the model, we are planning to manufacture several samples:

- Reference from SLAC design
- CLIC optimized with larger aperture
- Non-linear profile

Two materials are considered: Copper and Titanium

Update on manufacturing and testing

Manufacturing techniques consideration

“Classic” Machining with
Electric Discharge Machining (EDM)

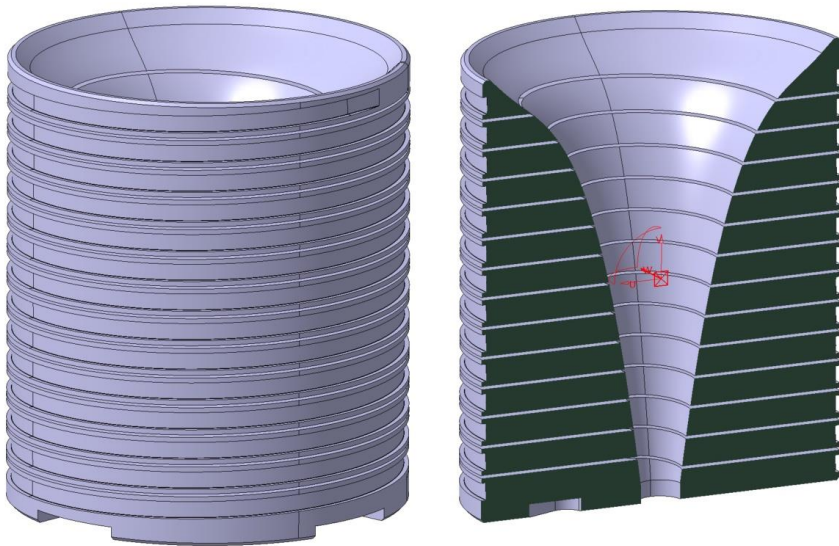

“Innovative” Machining with
3D printed (available at CERN with Titanium)

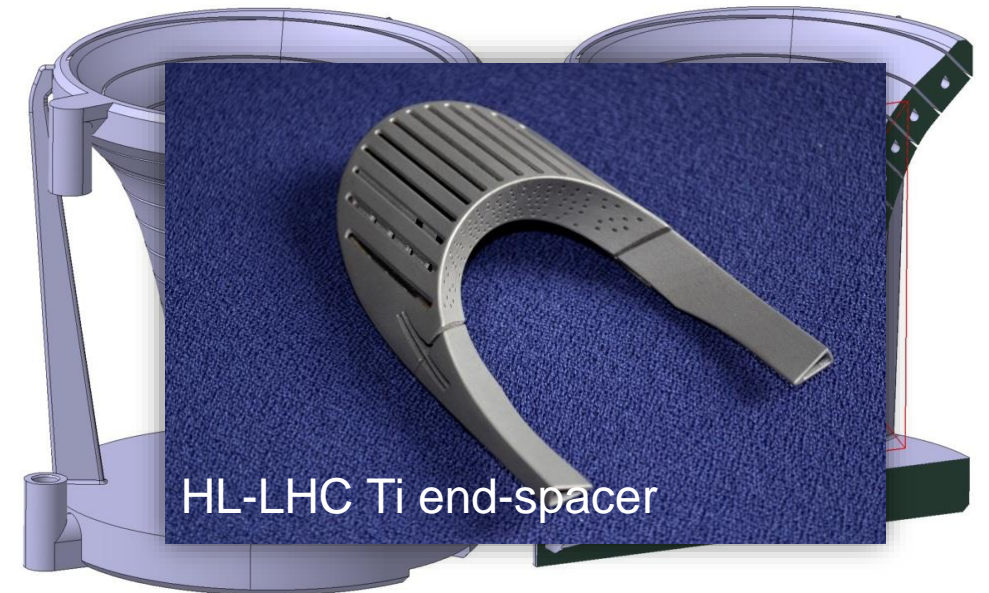

Update on manufacturing and testing

Produce prototype that can be integrated at the KEK test bench (see Enomoto's presentation)

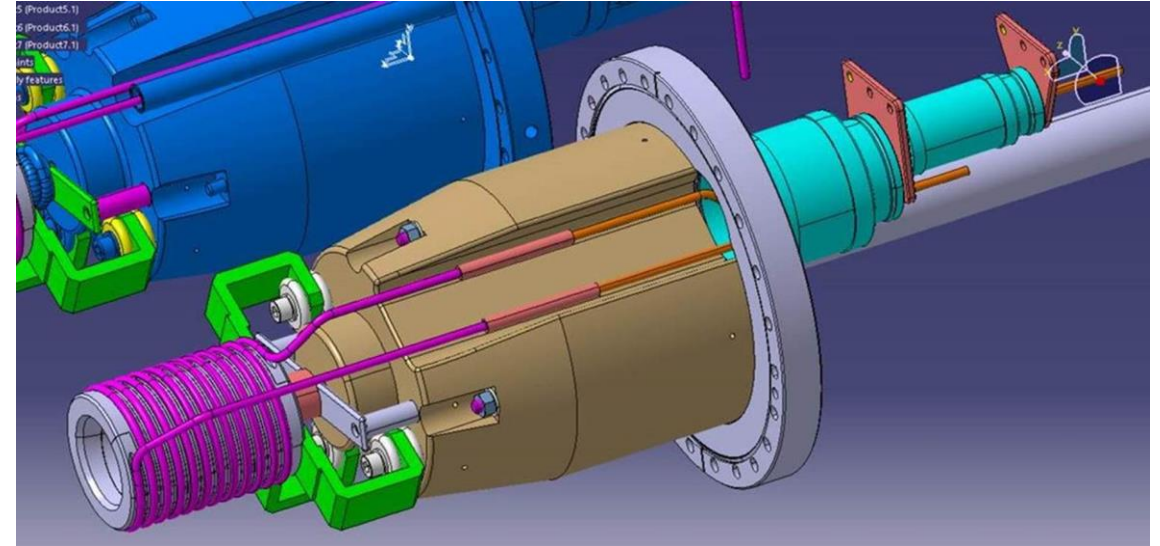
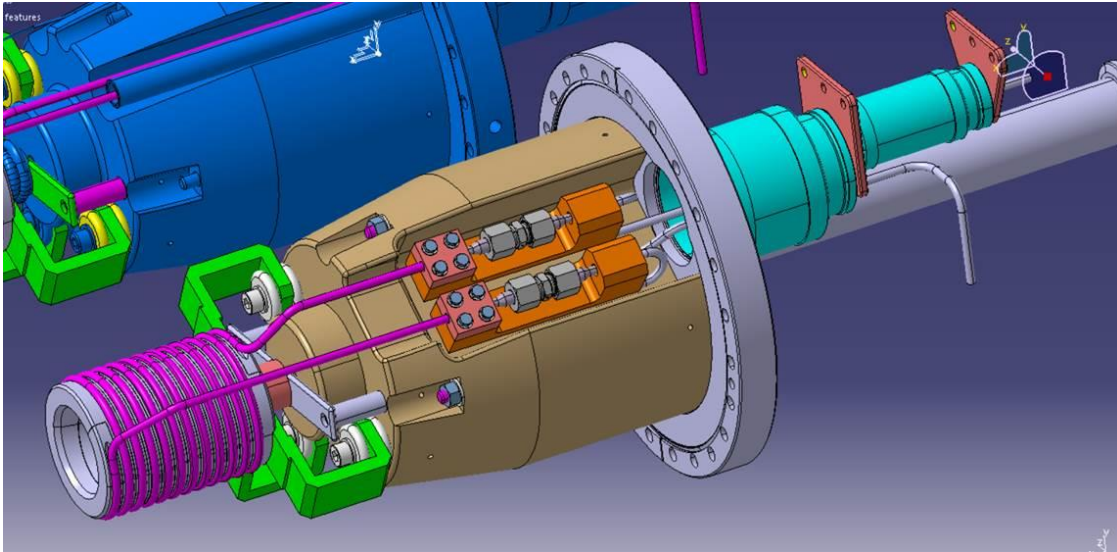

Conclusion

- Construction and validation of a transient electromagnetic model of Flux Concentrator using Opera[®] software.
- Parametric study for optimization of the electromagnetic behavior (voltage and field) to cope with breakdown voltage issue.
- Export of 2D field maps as input for particles tracking software packages (GEANT4, RF-track) and positron yield computations.
- New design of the coil's geometry using non-linear profiles for coupled optimization: electromagnetic, mechanical (Lorentz forces) and optical behavior (positron yield).
- The optimization process led to the doubling of the positron yield.
- Adapting the coil's profile (non-linear) limits the detrimental voltages and the Lorentz forces.
- Prototypes are planned to be manufacture at CERN and tested at KEK.



Backup

Design optimization for the CLIC e+ source

The shape of the FC profile significantly impacts the shape of the field distribution.

The downward concavity leads to:

- a broad distribution in the low field domain ($< 3\text{T}$) that extend to $Z=50\text{ mm}$
- Small fringe field $Z < 0\text{ mm}$

The upward concavity leads to:

- a “peaky” distribution in the high field domain ($>4\text{T}$)
- Larger fringe field

More complex shape:

- The field distribution can be more or less broad according to the design

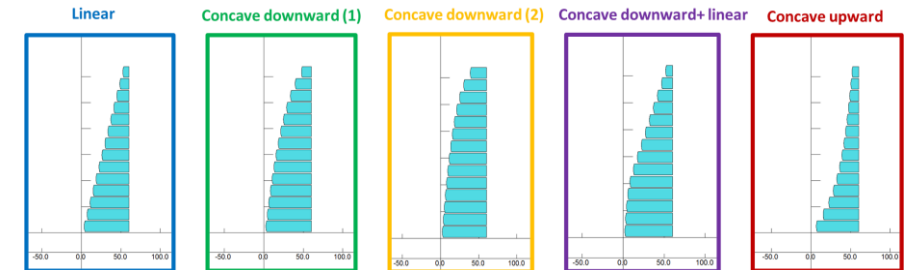
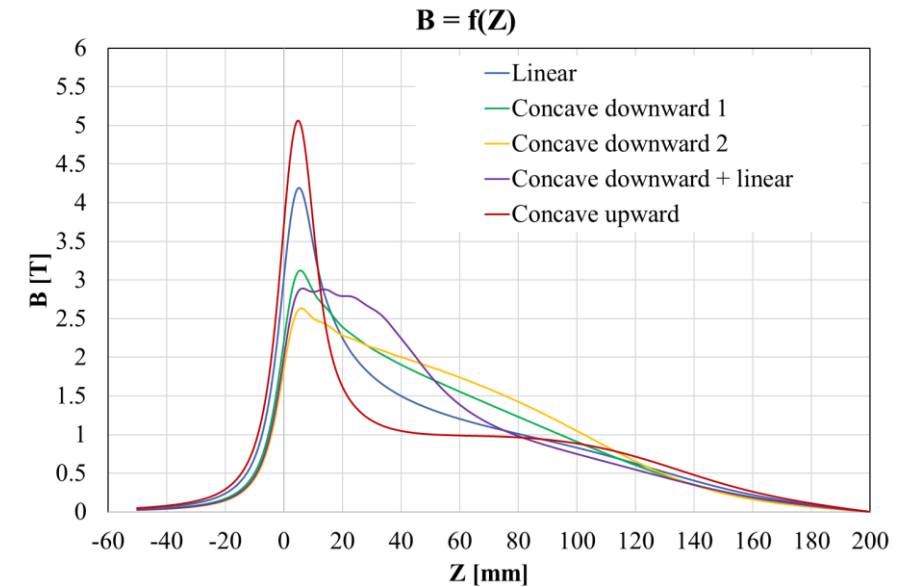

What is a «GOOD FIELD DISTRIBUTION» in terms of positron yield?

Modelling of the geometry

- 12-turn tapered solenoid (SLAC design)
- 2D model
- Axi-symmetric system
- Boundary conditions:
 - Tangential field for symmetry and far field
- Material properties
 - Conductivity with linear behavior (OFHC Copper)
- Regular mesh and mesh refinement:
 - quadrilateral Finite Element in conductor and Bias method
- Transient simulation:
 - Eddy Current and Skin effect

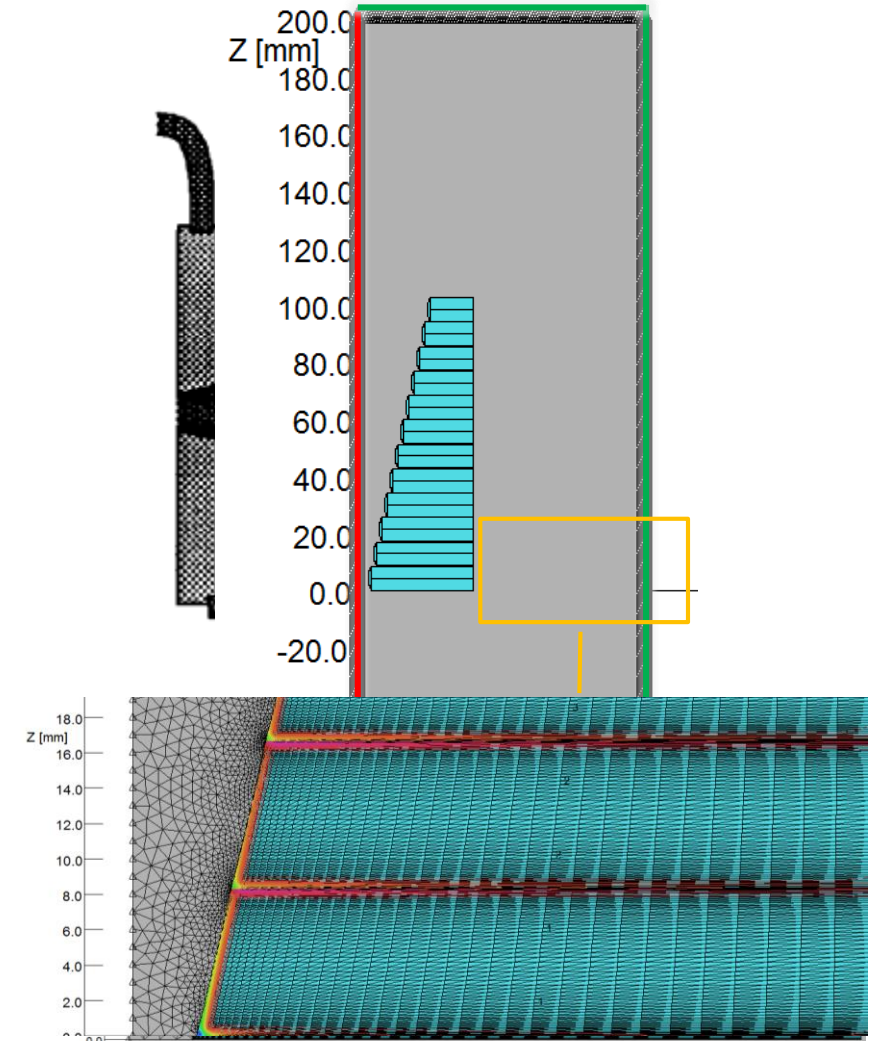

The origin of the field boost

Tapered solenoid in transient

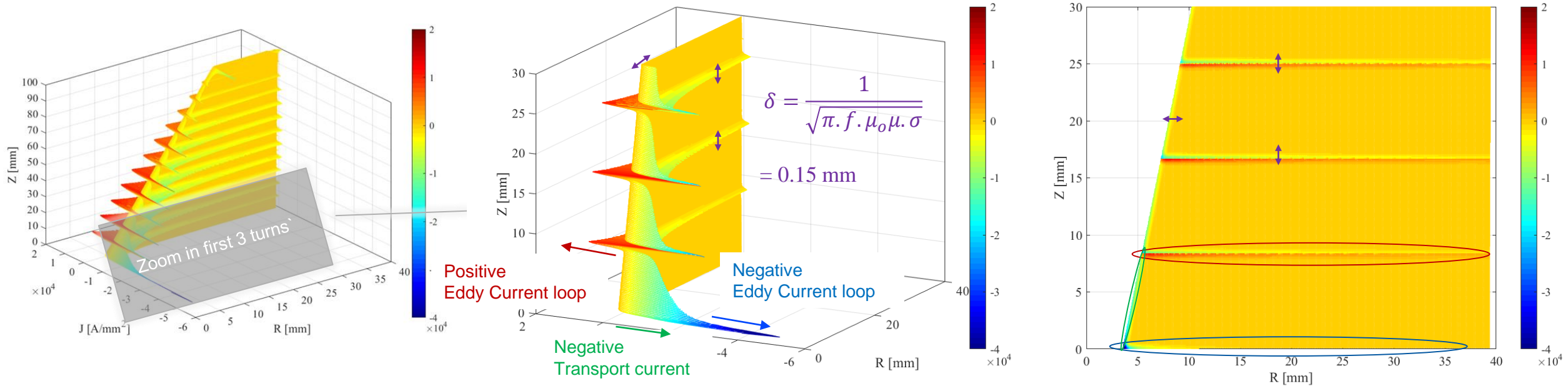

The pulse of current produces strong **eddy current loops** that circulate in opposite directions within each turn.

The current density concentrates at **the skin of the conductor**.

<https://agenda.linearcollider.org/event/8217/>

The eddy currents depend on the adjacent turns

Let's model
Two-turn coil

The current density
is both positive &
negative

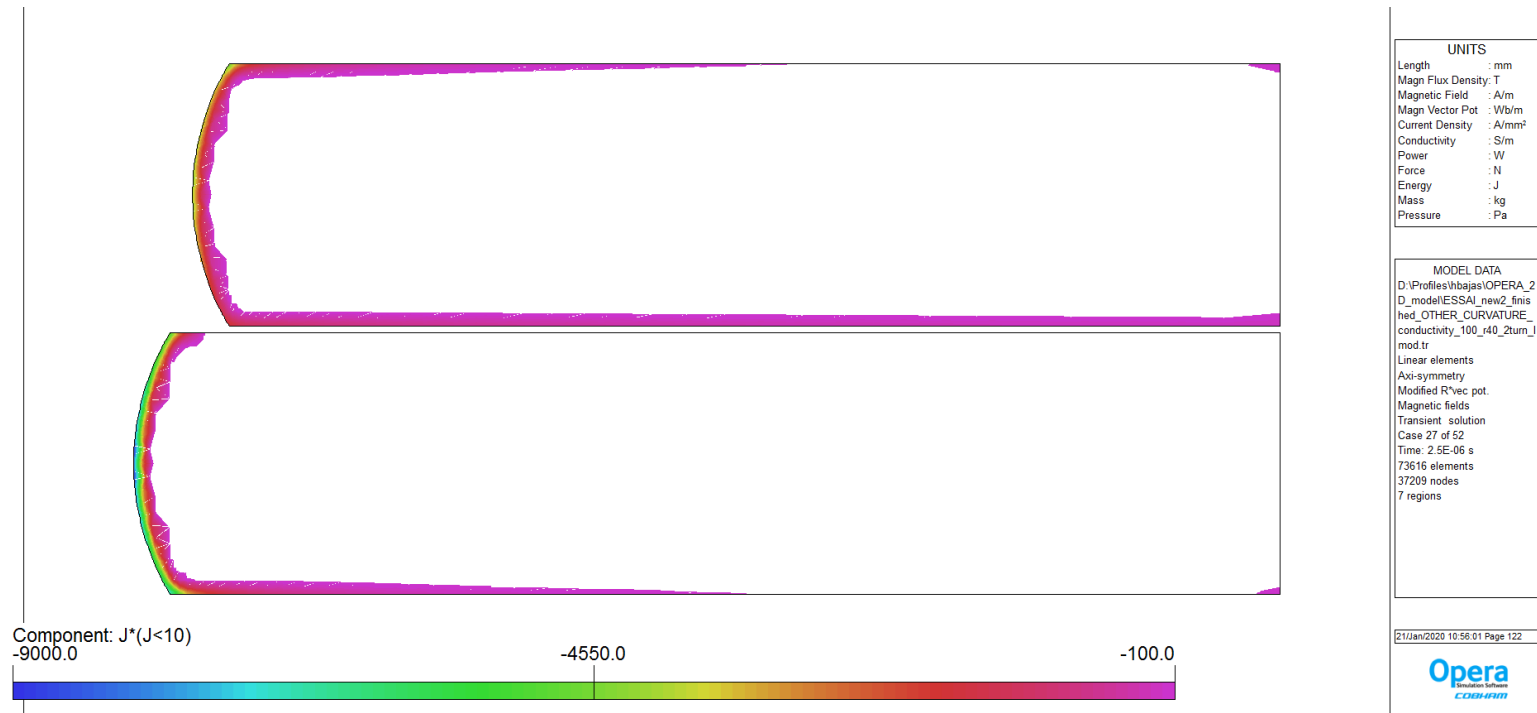

Third run of optimisation

The Lorentz force are now available as output data.

The forces are not only directed along the radius in the outward direction.

A significant compressive force applies to the FC along the solenoid axis.

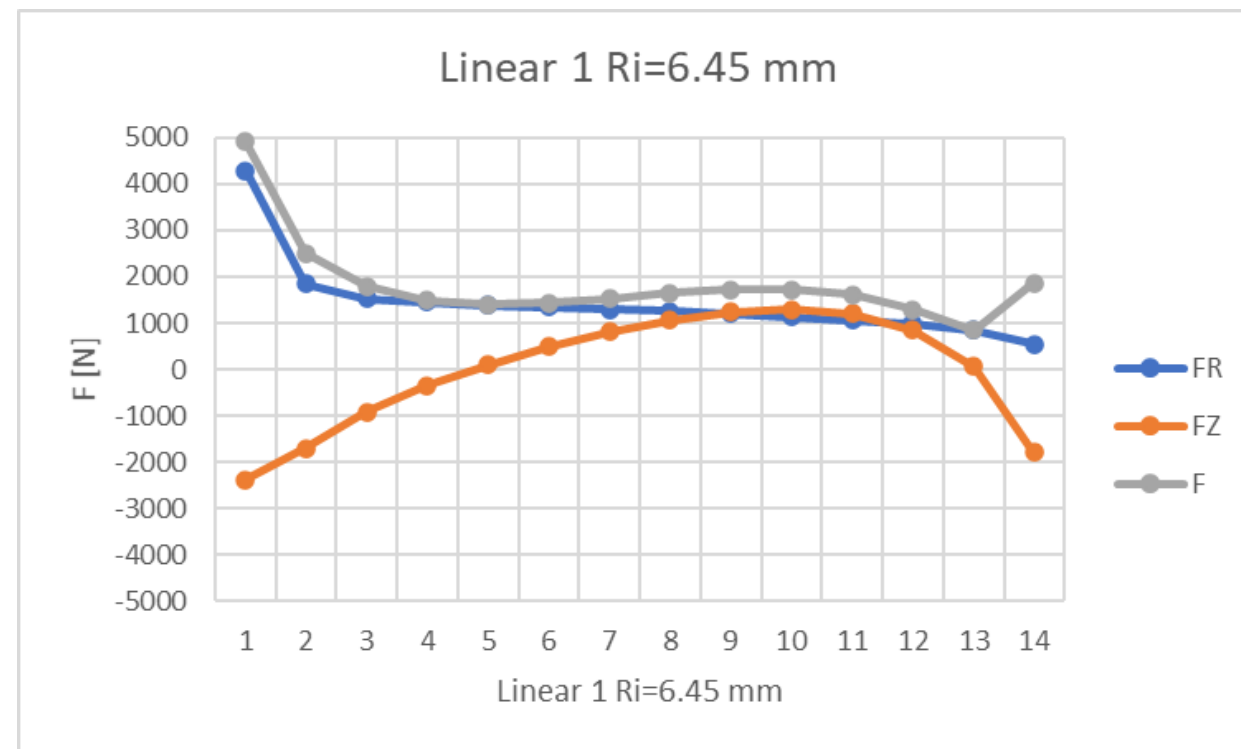

The distribution of the force along and accross the coil is complexe and need further investigation.

It changes a lot with the geometry.

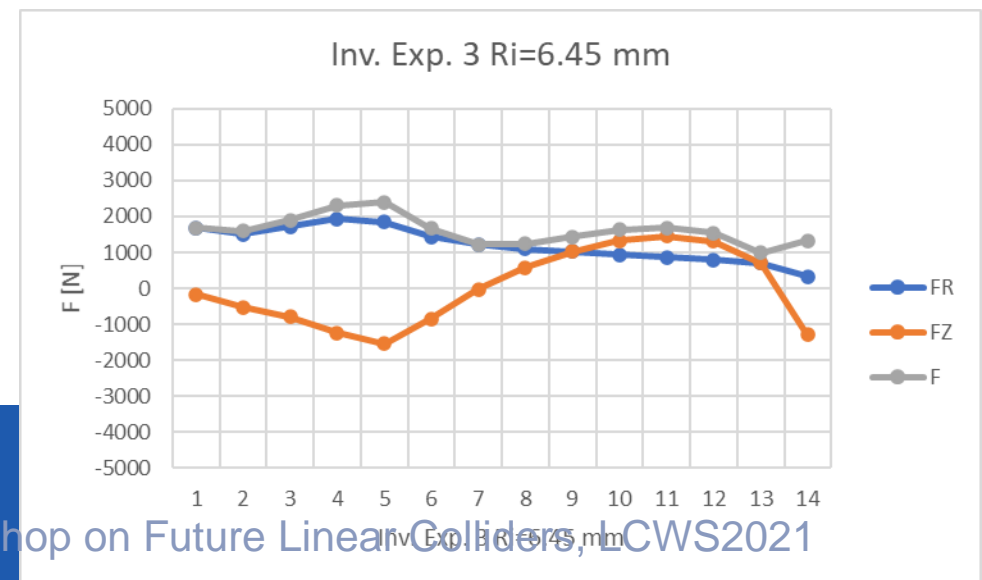
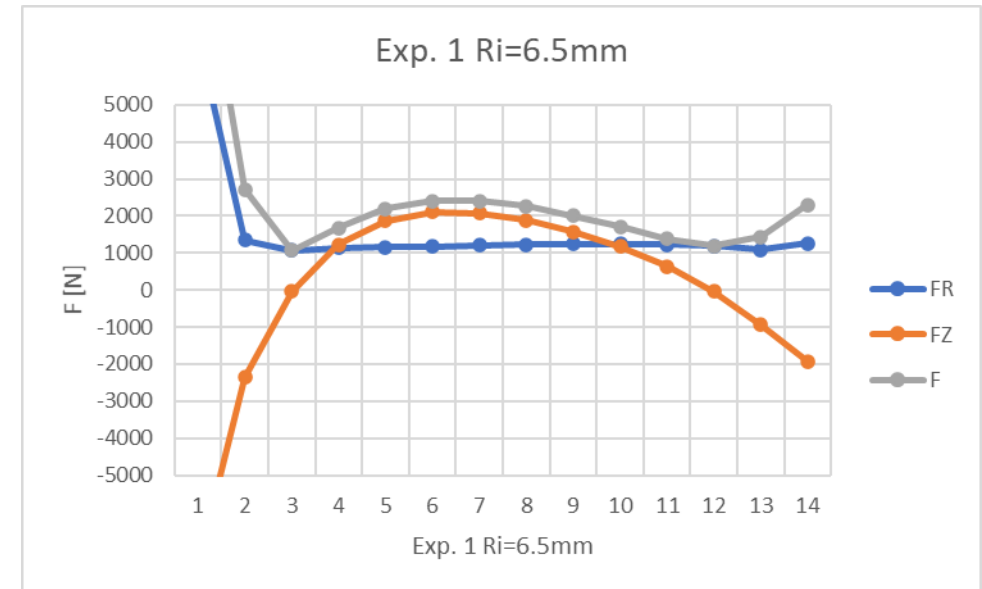

Design optimization for the CLIC e+ source

- Increasing the entrance aperture yields to higher positron but:
 - The field decreases with the aperture
 - The voltage increases with the aperture

R. H. Helm, SLAC, Report No. 4, August 1962.

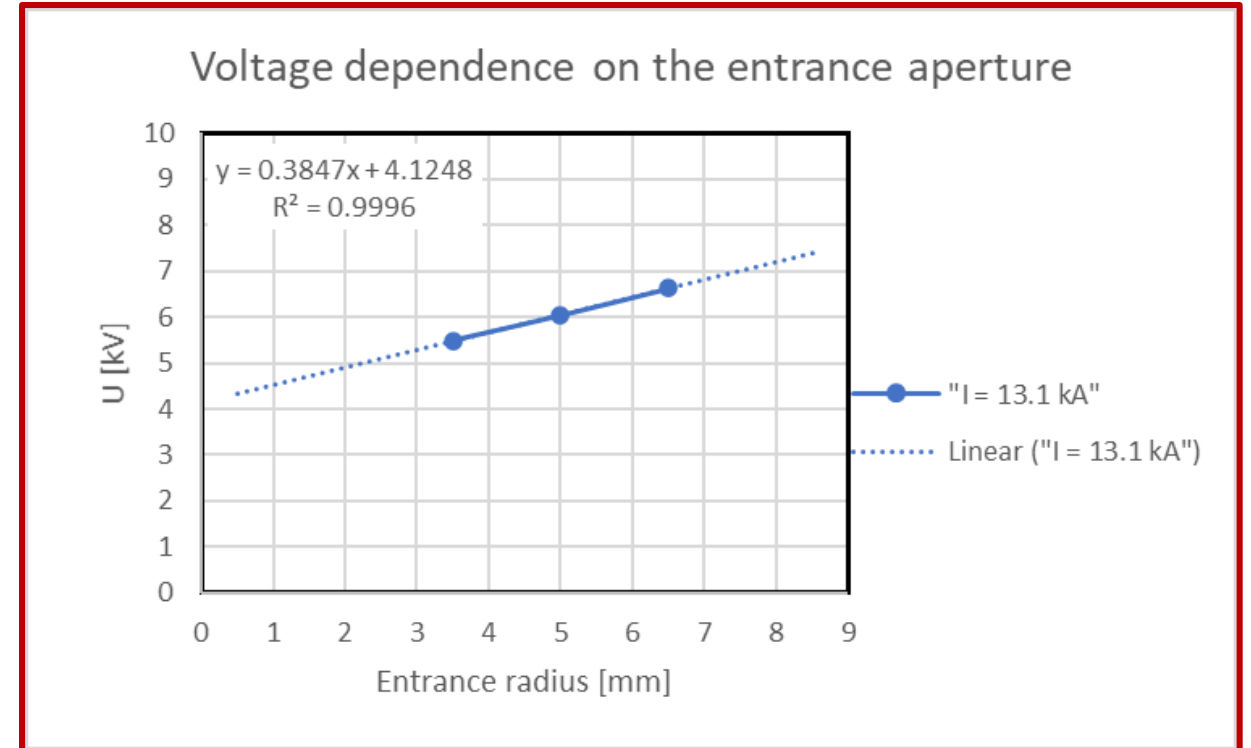
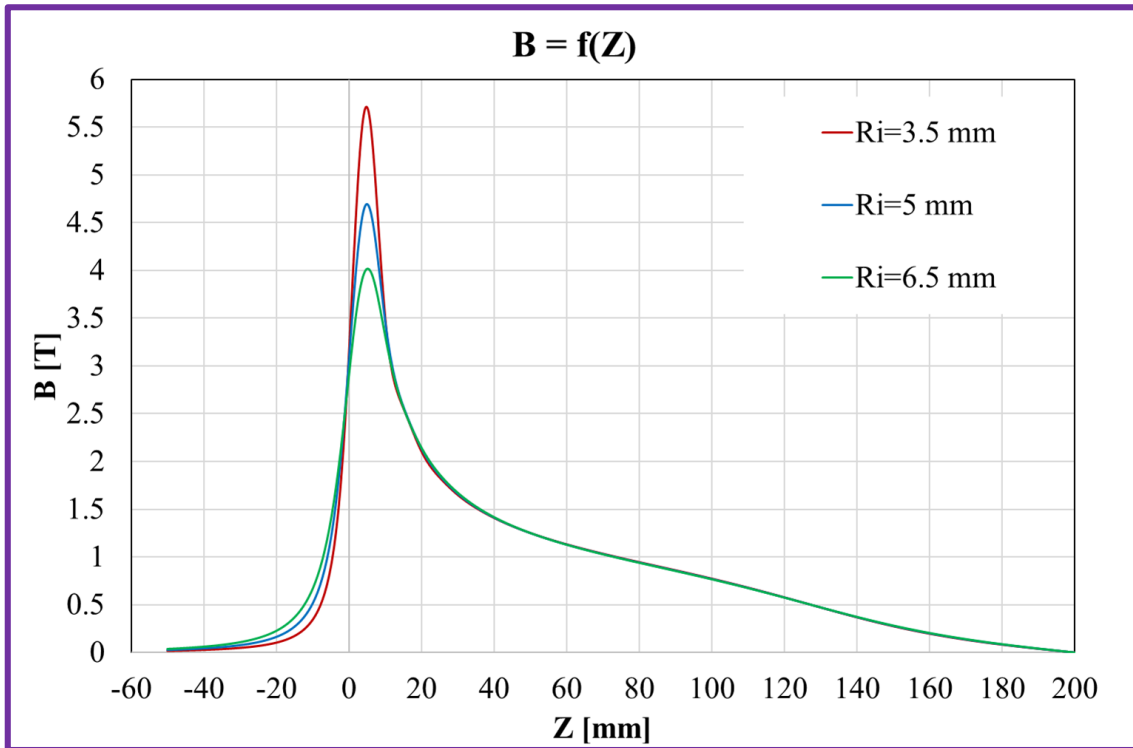

Design optimization for the CLIC e+ source

The voltage across the magnet is largely impacted by the coil design.

Still the tradeoff between Good Field Distribution and Voltage level should be done.

