

SRF Cavity Production at RI and Outlook for ILC

Michael Pekeler, 16.03.2021

RI Research Instruments

Facts and figures

- Founded in 2009
- Employees 270
 - ca. 110 physicists, engineers
 - ca. 120 manufacturing specialists
- Annual revenue: 45 million EUR
- Established with the core team of ACCEL Instruments GmbH (1994-2009) and of INTERATOM/Siemens
- Management holds significant equity stake in the company which is majority owned by Bruker EST, Inc.



Our customers

Industry:

- EUV tools
- Components for EUV lithography machines

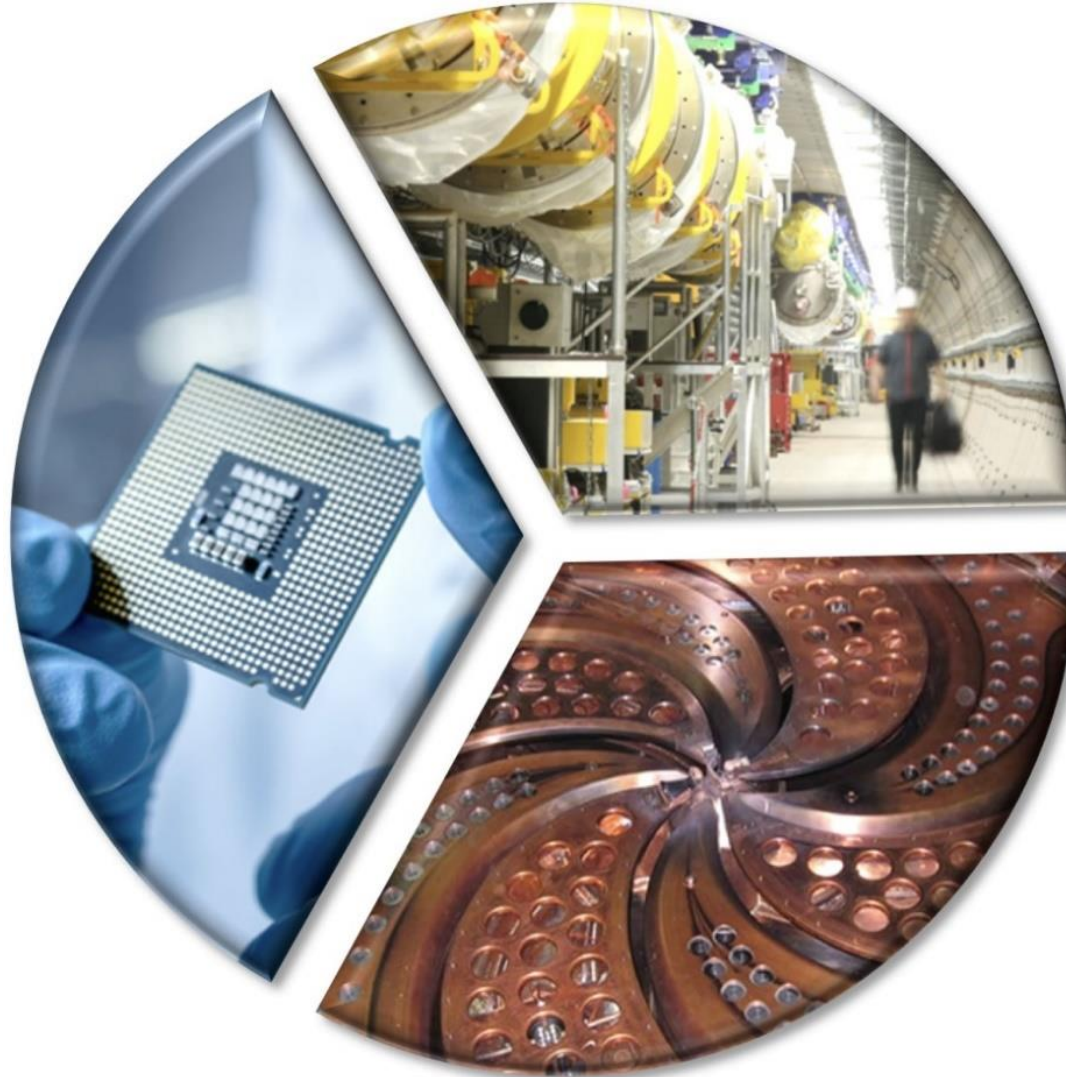

„Big Science“, worldwide institutes:

- SRF cavities and accelerator modules
- Fusion equipment
- Normal conducting cavities, RFQ's, linacs
- Photon instrumentation

Medical & pharma:

- Components for Varian proton therapy cyclotrons
- Design of SRF accelerator for Mo99 production

Our map of the world

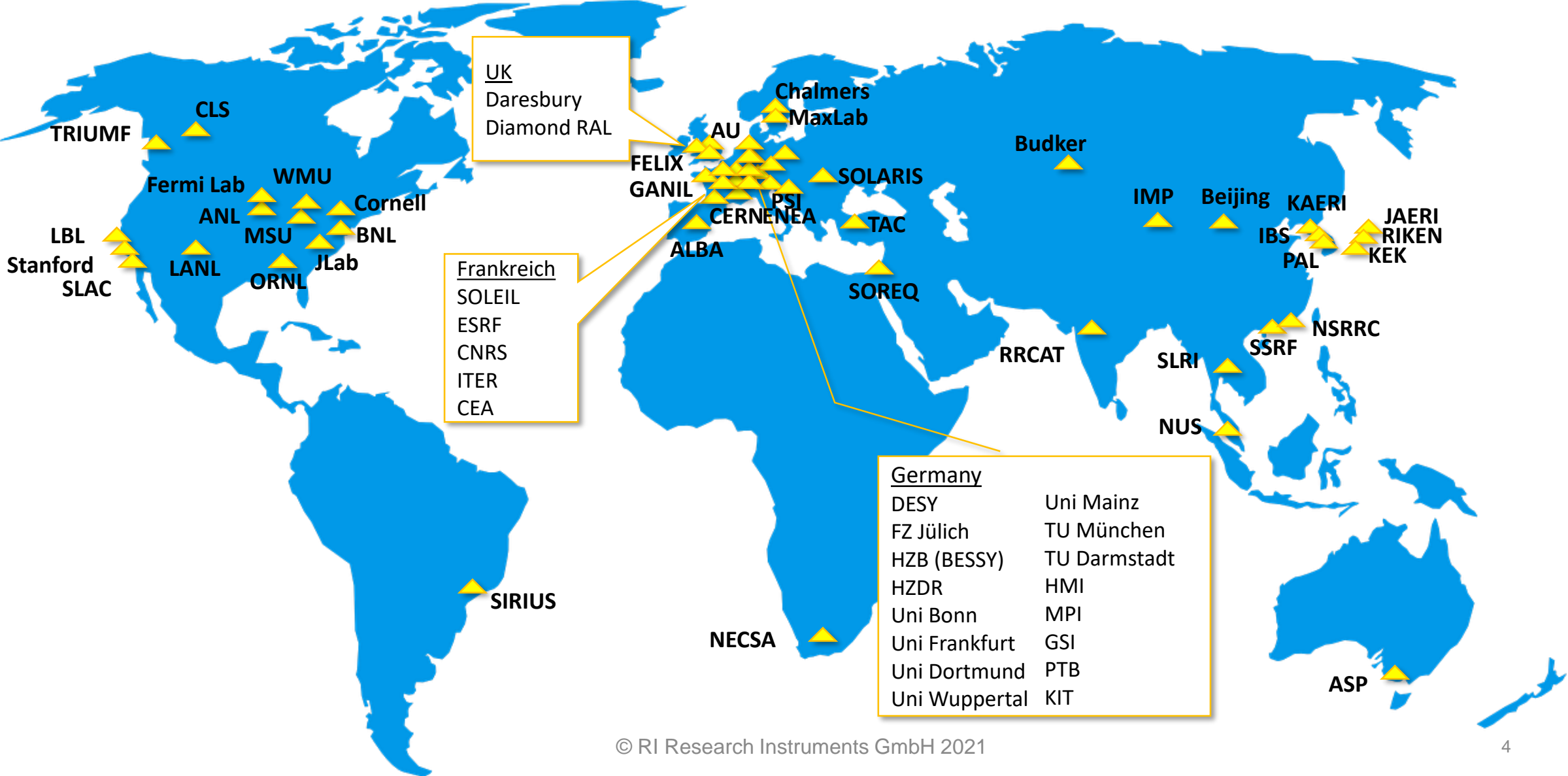

The RI manufactory

A one-stop-shop on 6000 m²



Metal working, milling, turning, coating



Electron beam, TIG, laser welding



Heat treatment, vacuum brazing

Big Science Projects

ITER – International Fusion Reactor

DC source for plasma heating, 50 A, 1 MV, finally 3x 50MW heating power at ITER

30m

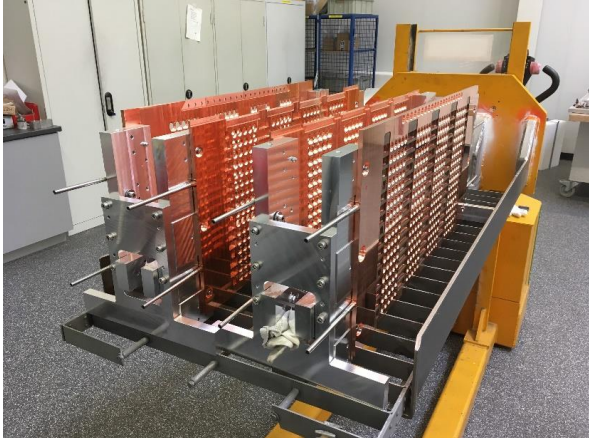
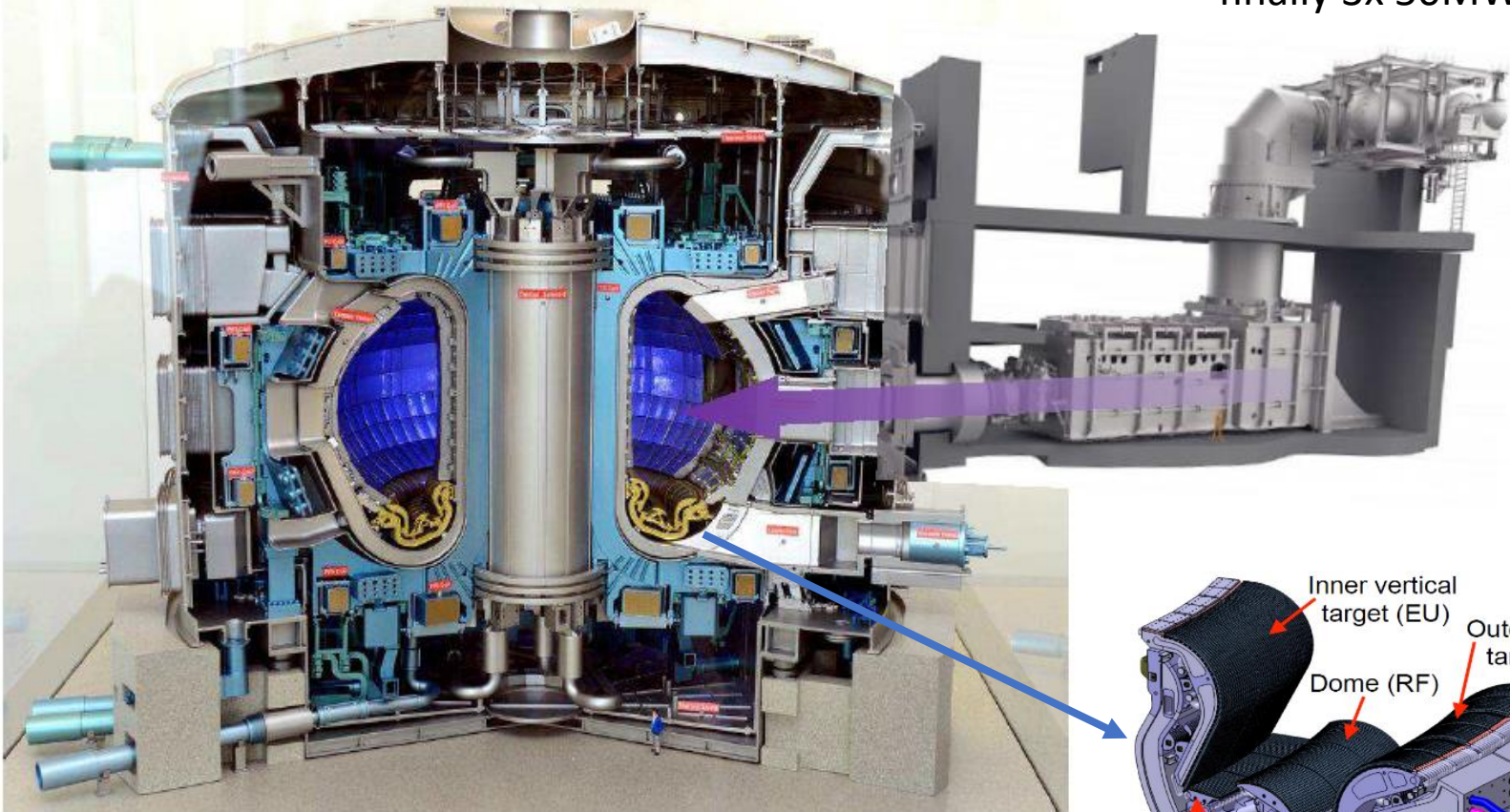

RI produces the grids for H⁻ particle acceleration

Ø28m

Divertor

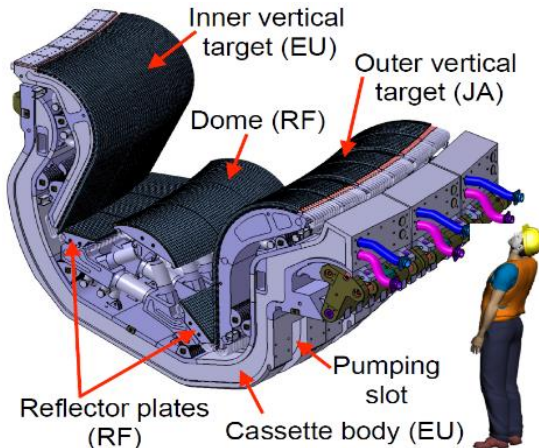

Inner vertical target (IVT) for ITER

The divertor is a heavily heat loaded water cooled component (10-20 MW/m² peak) with surface temperature of about 2400 C

- Tungsten monoblocks brazed to CuCrZr-pipe
- Stainless steel caseate for support and water distribution

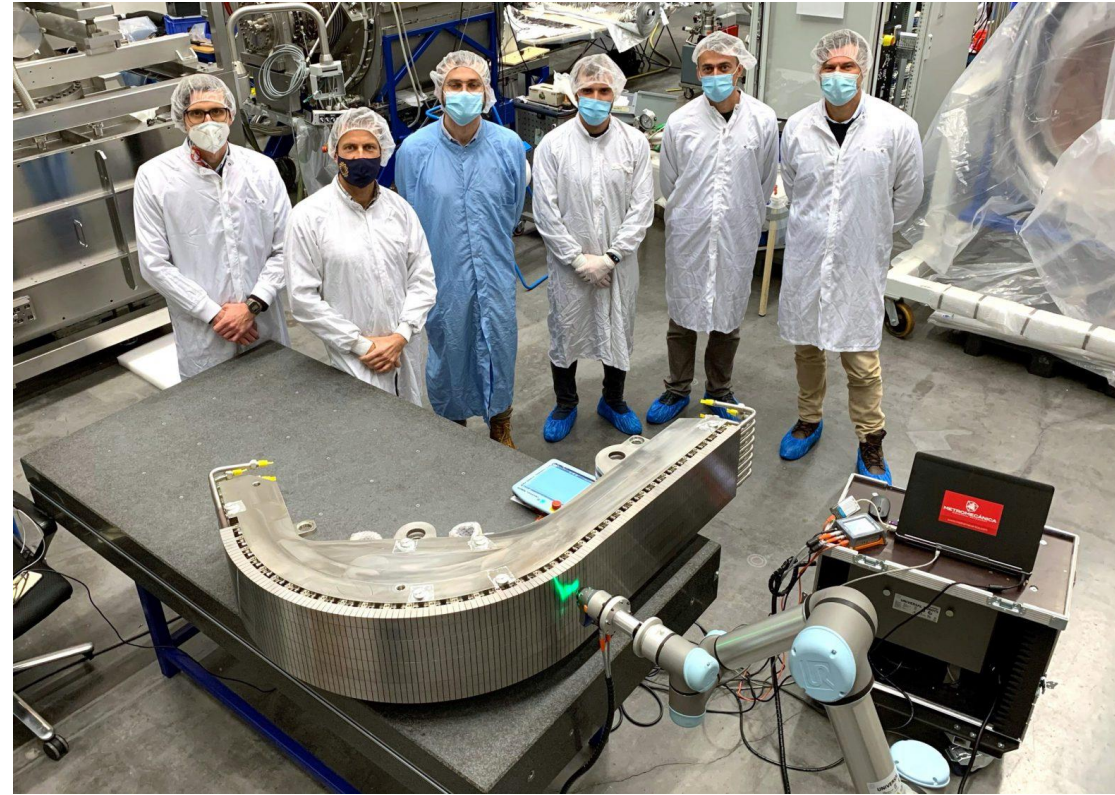

Valve boxes and cryopumps for ITER

- Design of valve boxes (cryogenic performance and thermal losses, radiation (1 MGy), earth quake)
- 8 valve boxes and 8 cryopumps under production at RI

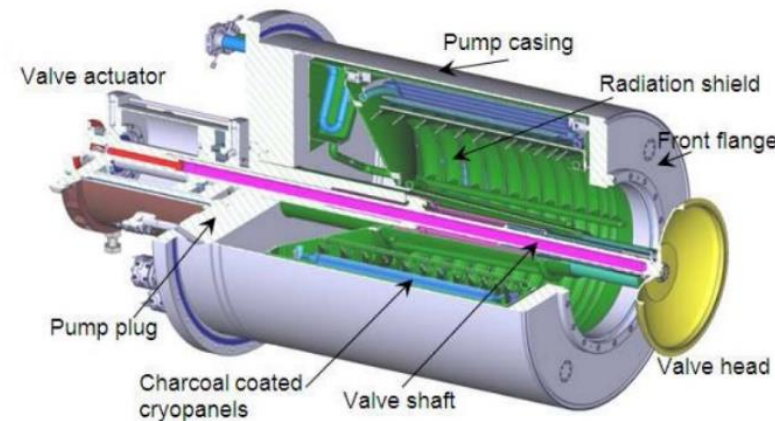
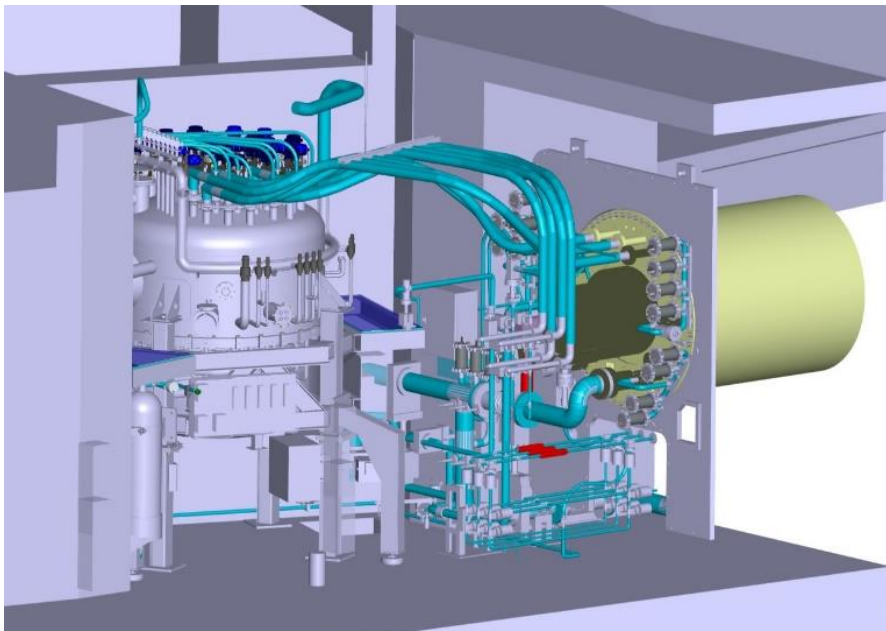

- Valve box contains 23 cryogenic valves, operated between 4 K and 500 K
- Cryopumps (3 m length, 1,5 m diameter) contains big all metal valve for 30 000 cycles

500 MHz SRF accelerator modules

Technology transfer from Cornell University, USA

2 SRF modules	for NSRRC,	Taiwan
2 SRF modules	for CORNELL,	USA
3 SRF modules	for CLS,	Canada
4 SRF modules	for DLS,	Great Britain
3 SRF modules	for SSRF,	PR China
4 SRF modules	for PAL,	Korea
2 SRF modules	for CNPEM	Brazil

Total 20 SRF modules

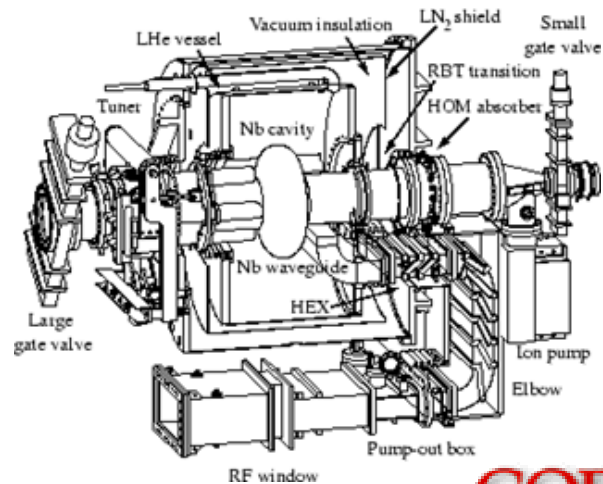

- Cavity production, surface preparation and test
- Coupler production and conditioning
- Ferrite style HOM loads
- Module assembly,
- **Installation and comissioning on customer site**
- **Valve boxes, transfer lines, Controls, interlock and data acquisition system**

Other examples of technology transfer from laboratories to RI

10 x SRF modules of the ELBE type (HZDR, Germany)

- STFC (2 modules)
- University of Mainz (2 modules)
- University of Ankara (2 modules)
- NCBJ, Poland (4 modules, after some redesign at RI)

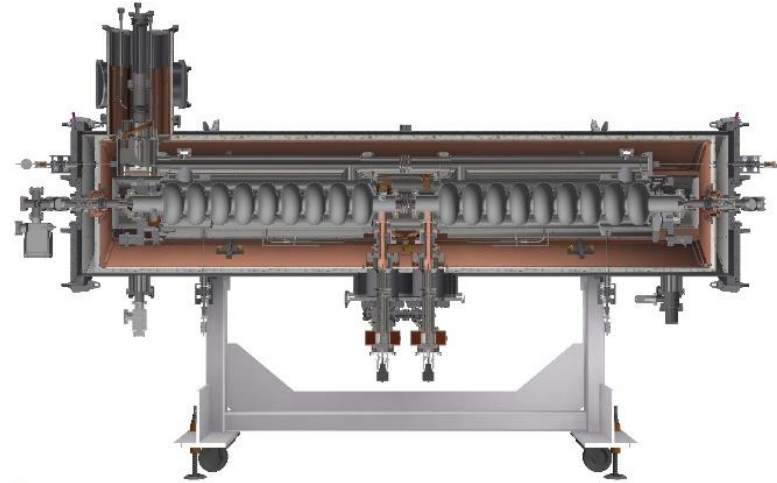

58 x S-Band accelerator structures from DESY, Germany

- SLS (2 structures)
- DLS (2 structures)
- ASP (2 structures)
- PTB (1 structure)
- TLS (3 structures)
- University Nijmegen (1 structure)
- NSLS-II (BNL) (4 structures)
- Max-IV (40 structures)



23 x 500 MHz HOM damped cavities from HZB, Germany

- ALBA, Spain (7 cavities)
- HZB (8 cavities)
- DLS (3 cavities)
- LBNL (3 cavities)
- DELTA, Dortmund, Germany (1 cavity)
- PAL, Korea (1 cavity)

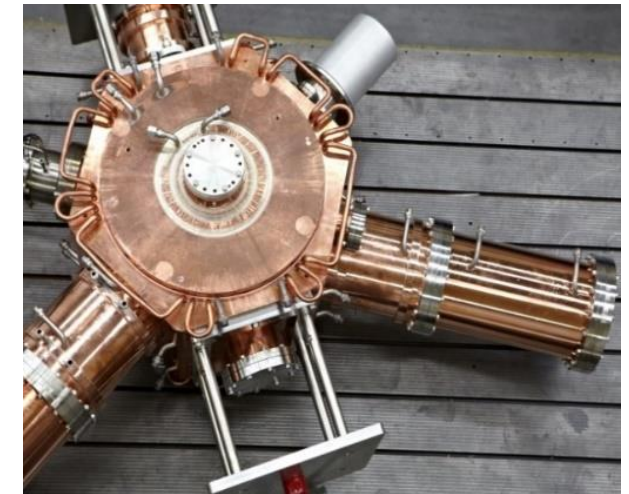

Superconducting RF Cavity Production

ILC type SRF cavity production

420 cavities for European XFEL
at DESY from **2010 to 2015**

210 cavities for LCLS-II
at SLAC from **2015 to 2018**

168 cavities for LCLS-II-HE
at SLAC from **2021 to 2022**

Additional 170 such cavities for various customers since **1995** (DESY, FNAL, Stanford, MESA, PoFEL, STFC, HZDR, SOLEIL, HZB, Ankara University, SINAP)

- Total of **968 pcs 1.3 GHz 9-cell cavities** produced so far in our premises
- in average 35 ILC type cavities per year since **1995**
- In average 70 ILC type cavities per year since **2010**



SRF cavity assembly in ISO 4 clean room



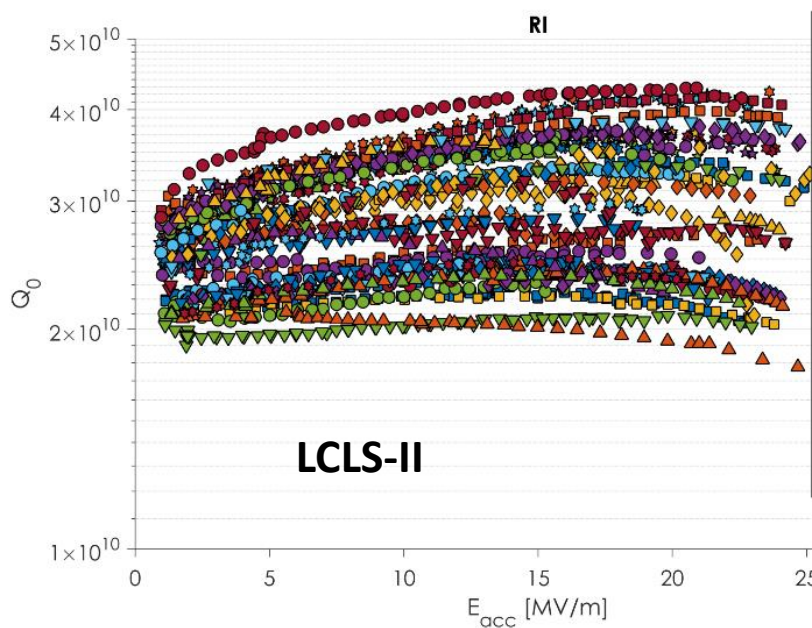
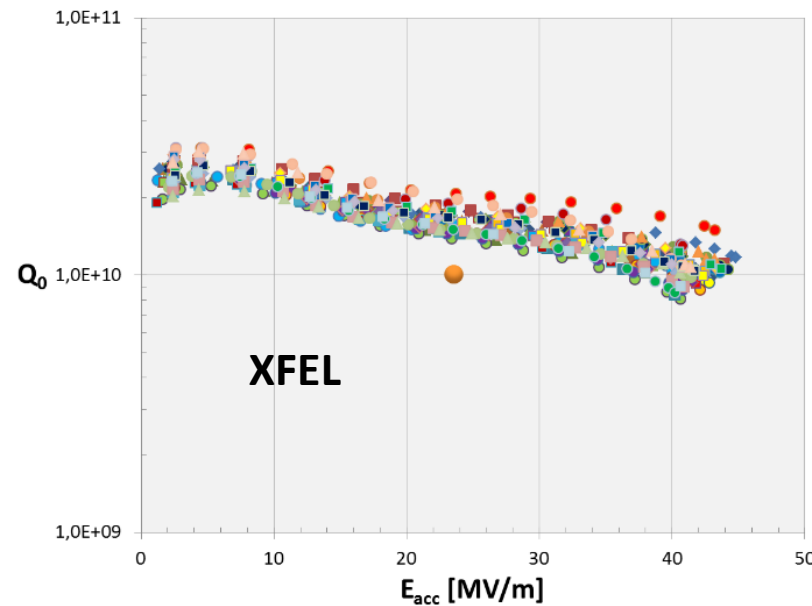

Cavity results

Industry Produced 9-Cells with New Processes

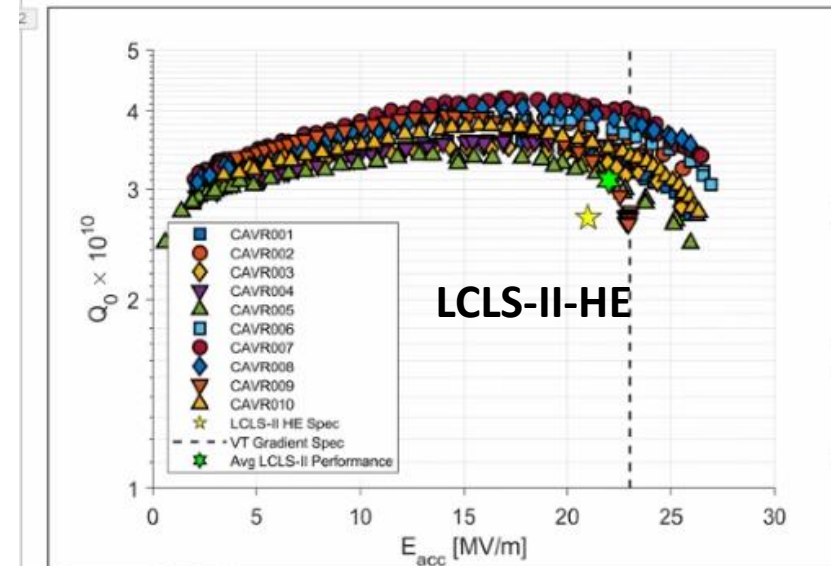

$$\langle E_{acc} \rangle = 25.3 \text{ MV/m}$$

$$\langle Q_0 \rangle = 3.5 \times 10^{10}$$

- LCLS-II HE commissioned the construction of 10 9-cell cavities from industry, produced with the 2N0 recipe for use in a *verification* cryomodule
- The improved processes described here and many more were implemented in the production
- All of the cavities passed the HE specification!
- Improvement of >3 MV/m compared with the LCLS-II average!

Cavities are shipped under vacuum and „ready for RF cold testing“

Ongoing SRF cavity production at RI

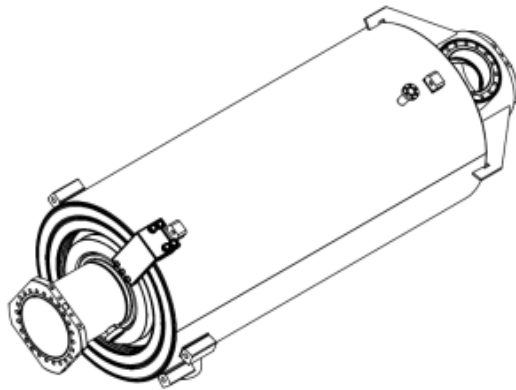

***20** of 88x ESS high beta for
UKRI

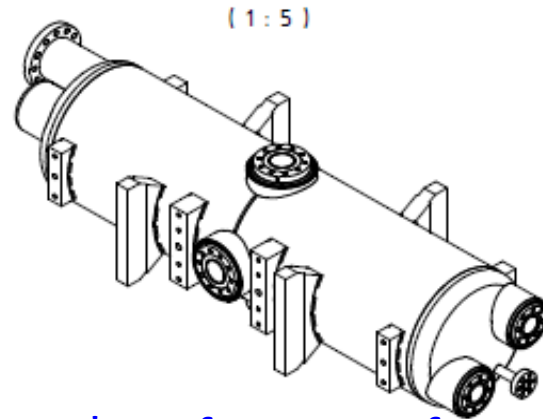

***20** of 52x HWR for IBS
project

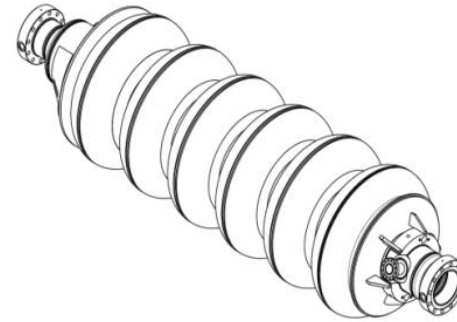

*** 2** of 30x PPU cavities
for ORNL

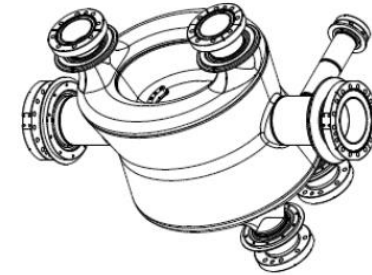

***9x** crab cavities
for CERN

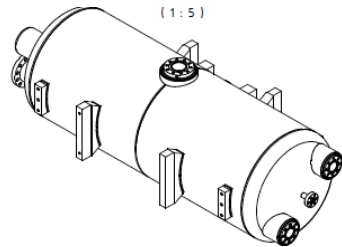

23 of 29x HWR for
CEA/SARAF

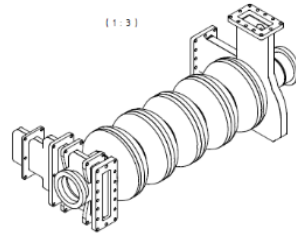

16 x C75 cavities
for JLAB

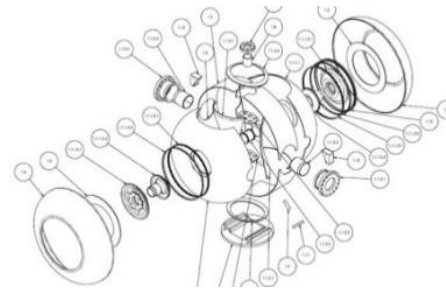

***2** SSR2 spoke for IBS

In addition to the 168 LCLS-II-HE cavity production, 12 x 1.3 GHz 9-cell cavities for SINAP and various other prototype cavities are currently under production

In total 325 cavities need to be delivered until end of 2022
about 160 cavities per year are produced at RI in 2021 and 2022

***Scope includes surface preparation (BCP/EP, HPR, cleanroom assembly)
Only mechanical manufacturing**

SARAF cavities for CEA



C75 Cavities for JLAB



CRAB Cavities for CERN



SRF cavity production capabilities at RI

- 70 technician and 15 engineers/managers are producing about 165 cavities of various types at RI already now
 - 2 shift operation
 - 2 EB welding machines
 - 1 800 C furnace
 - 1 EP plant
 - 1 BCP plant
 - 4 turning machines
 - 2 dimensional control spaces
 - 1 tuning machine
 - 120 m2 ISO 4 clean room



- For only ILC type cavity production, we could produce already now about 200 cavities every year
- Doubling the working time per week by going from 2 shift at 5 days (now) to 3 shifts at 7 days (ILC) and with some minor modification, RI could produce with the available infrastructure about 400 cavities per year (2000 cavities within 5 years)
- Would need about 130 technicians and 25 engineers/managers for 400 cavities per year

ILC cavity production

- For higher production numbers (> 400 cavities per year), the infrastructure at RI needs to be enlarged
- Study performed for DESY on ILC production cost in 2012. Cavity production cost can be reduced by > factor 2 compared to EXFEL production when producing > 9,000 cavities within 3 years series production time.

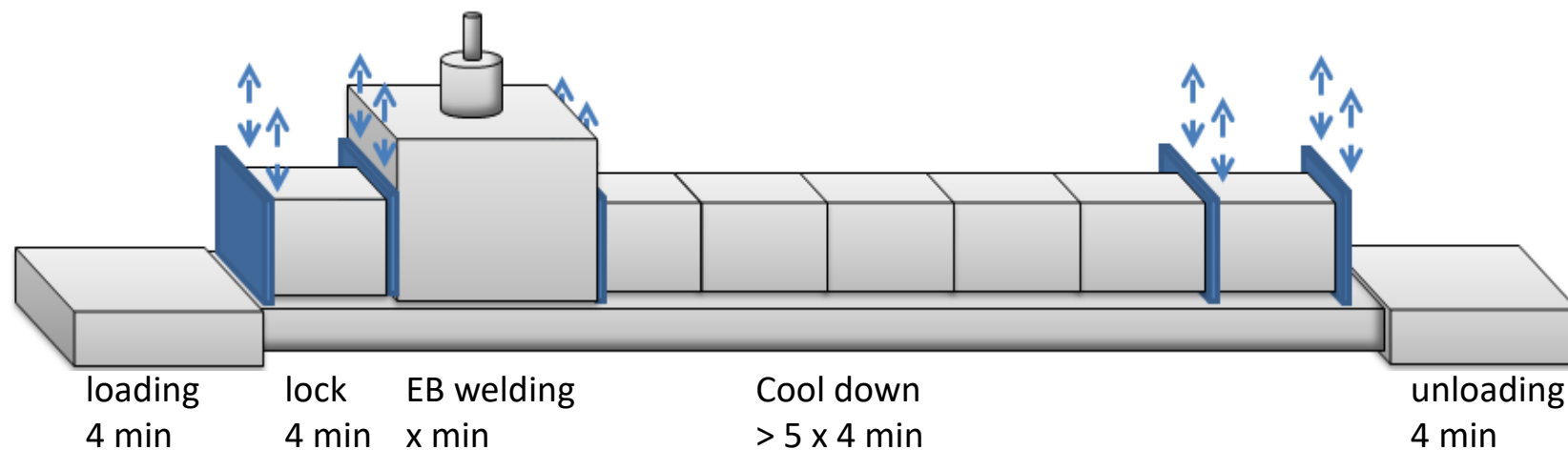
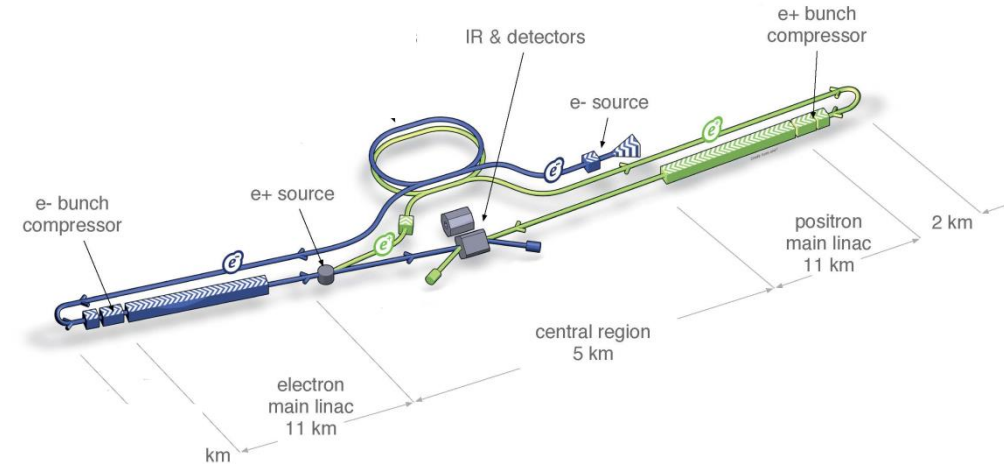

2012 ILC cavity production study

Personnel needed for 9,000 cavities produced in 3 years ILC series production

Required personnel for ILC	per shift	Hired
Technician for mechanical manufacturing	36	176
Technician for surface preparation	37	181
Total technicians/operators	73	357
Supervisors of technicians/operators	15	60
Total number of persons working shift	88	417
Project and Quality Managers, Maintenance (no shifts)		45
Persons working for ILC cavity project		452

Our site(s) in Bergisch Galdbach – RI expanded from 100 people to 270 people since 2009

RI site at Technology Park

New RI site in Obereschbach

RI space (sqm)	office	Production	sum
As of today	1.900	7.400	9.300
Additional in 2022	900	6.000	6.900
Total in 2022	2.800	13.400	16.200

Space for extended production facilities (8000 sqm) available for further expansion > 2022

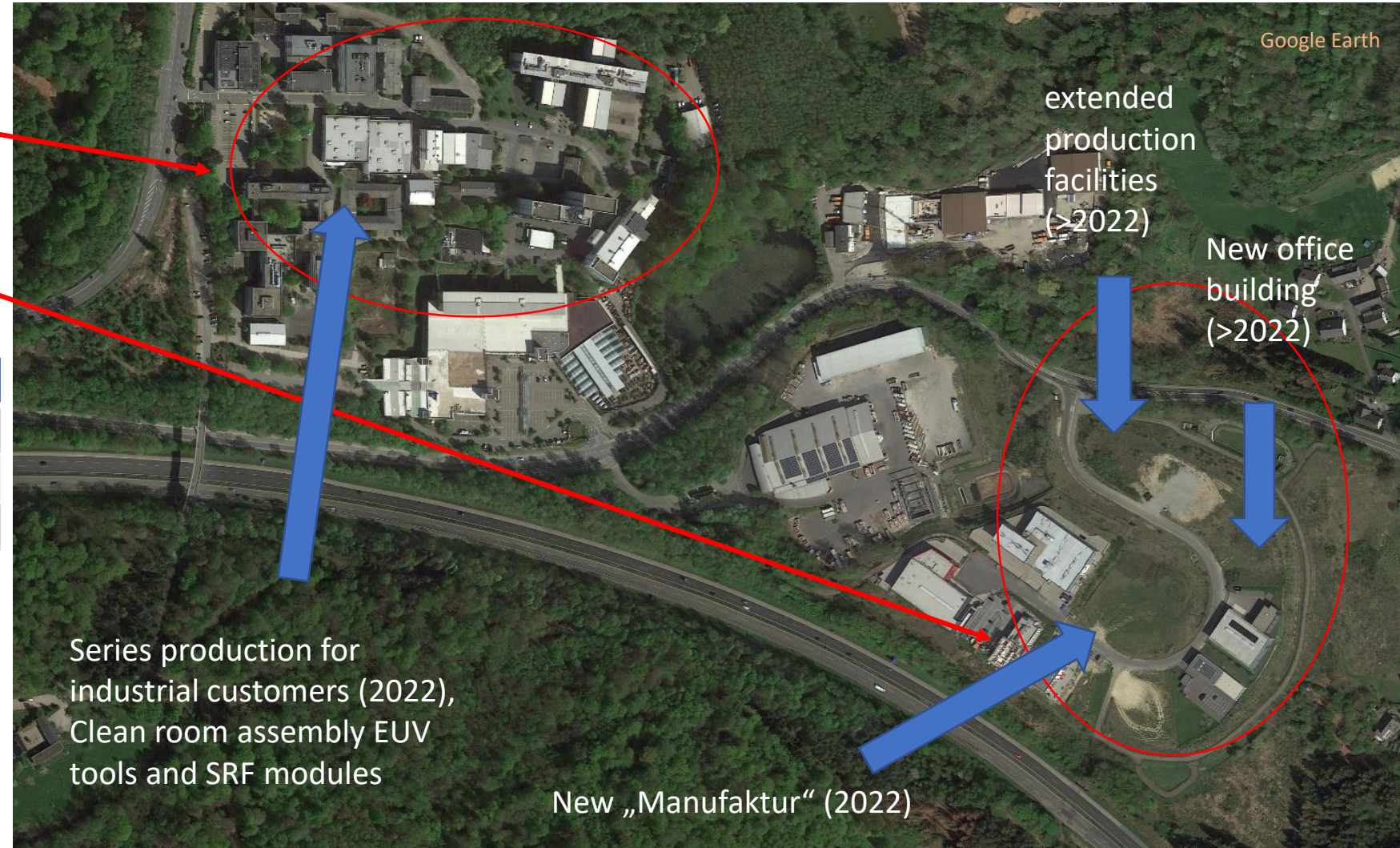

Our site(s) in Bergisch Galdbach – RI expanded from 100 people to 270 people since 2009

RI site at Technology Park

New RI site in Obereschbach

RI space (sqm)	office	Production	sum
As of today	1.900	7.400	9.300
Additional in 2022	900	6.000	6.900
Total in 2022	2.800	13.400	16.200

Space for extended production facilities (8000 sqm) available for further expansion > 2022

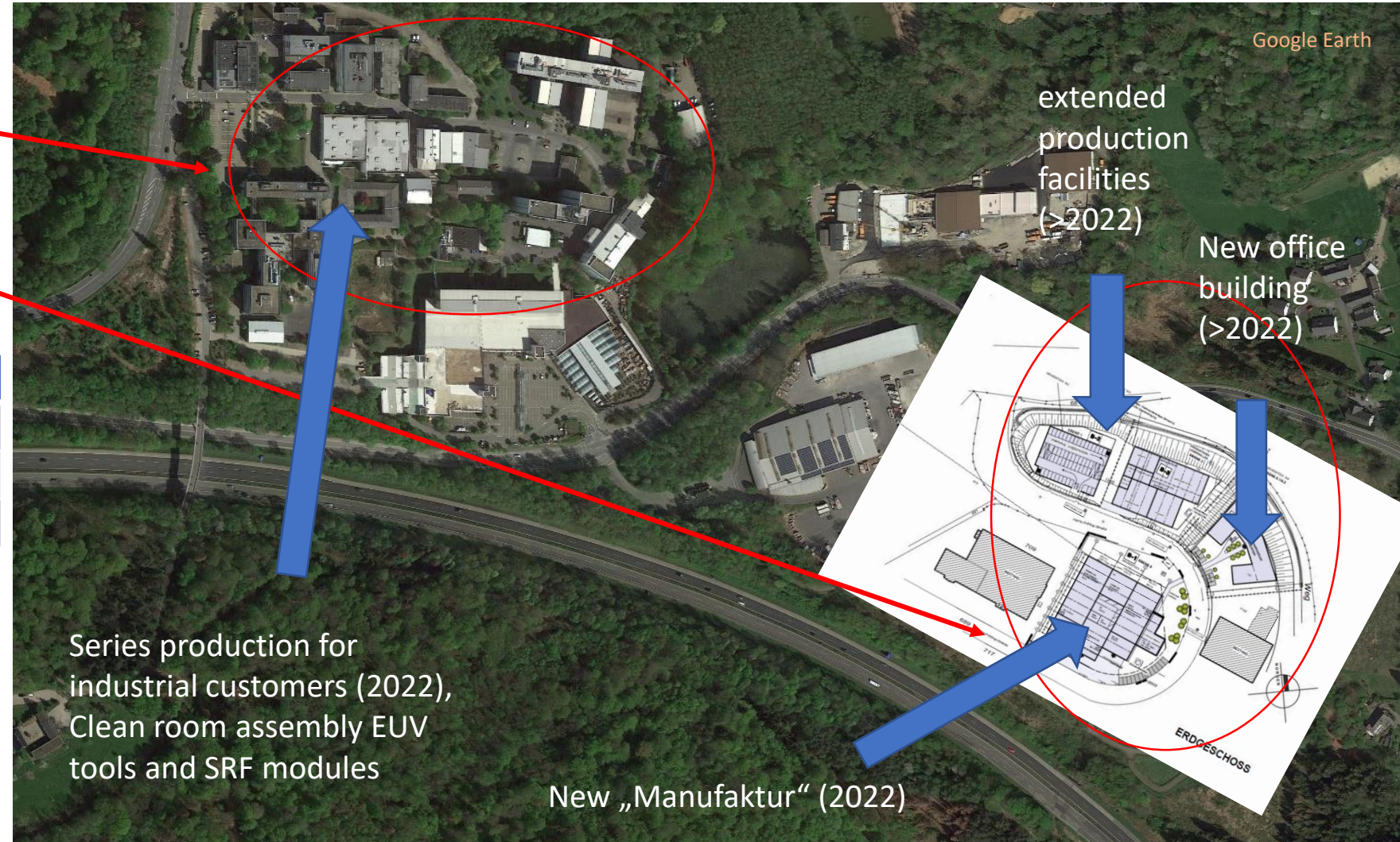

Summary

- SRF cavity production “ready for cold RF testing” and at large numbers with state of the art performance is already well established in industry
- 400 ILC cavities could be produced at RI with current infrastructure every year
- Collaboration between institute and industry proven to work for challenging scientific projects using SRF technology
- Cost reduction of factor 2 compared to today’s price feasible in case of production of very large number of ILC cavities per year