

LCWS2021

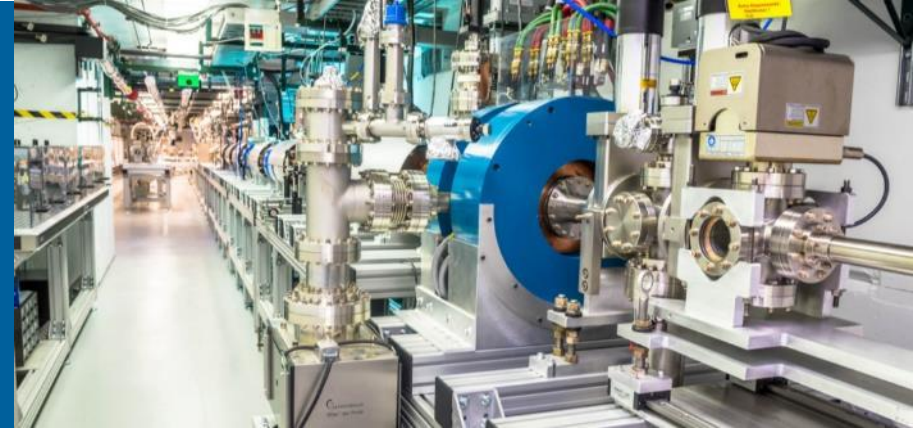

SHORT-PULSE WAKEFIELD STRUCTURE R&D FOR HIGH GRADIENT AND HIGH EFFICIENCY ACCELERATION



CHUNGUANG JING

On behalf of the AWA facility at
Argonne National Laboratory

BACKGROUND

- **Power extractor driven by high charge beam**

Normal conducting at room temperature (X-band long pulse):

150 MV/m (single-cell), 120 MV/m (multi-cell)

Normal conducting at cryogenic temperature (X-band long pulse):

250 MV/m (single-cell), 150 MV/m (multi-cell)

- **Short-pulse acceleration is a promising approach to achieve high gradient**

Experimental observation of BDR dependence on gradient and pulse length

$$BDR \propto E^{30} \tau^5$$

New breakdown physics may exist in short-pulse regime

- **Short-pulse acceleration requires special structure R&D**

High gradient
(0.3-1 GeV/m)

$$E \propto \sqrt{\omega r / Q}$$

High shunt impedance

High efficiency
(AC-to-RF >30%)

$$\eta \propto t_{flat} / t_{pulse}$$

High group velocity

SHORT PULSE RF SOURCE AT AWA

- Power extractor driven by high charge beam

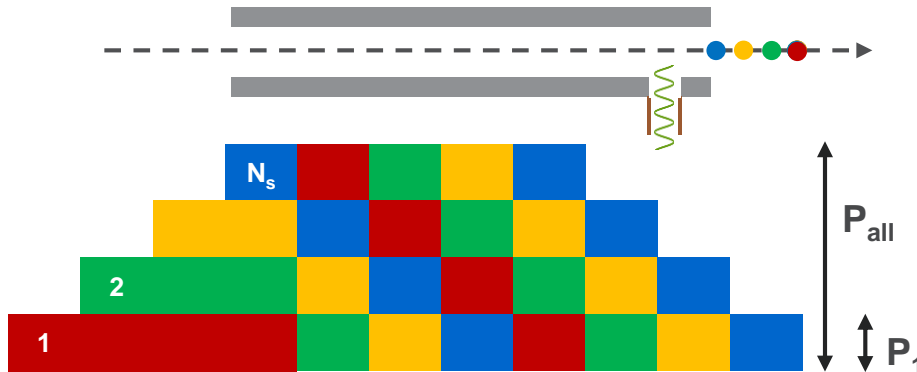

$$P_{all} = P_1 N_s^2$$

$$P_1 = \frac{c \beta_{g,PETS} \kappa_{L,PETS}}{1 - \beta_{g,PETS}} Q_b^2 F^2$$

Metallic disk-loaded

400 MW, 3 ns flat-top

Dielectric-loaded

200 MW, 3 ns flat-top

Metamaterial

400 MW, 1 ns flat-top

C. Jing et al, *NIMA* **898**, 72 (2018)

J. Shao et al, *PRAB* **23**, 011301 (2019)

X. Lu et al, *PRL* **122**, 024801 (2019)

RECENT SHORT-PULSE RF BD STUDY AT AWA

Credit to Maomao Peng (TSU) and Jiahang Shao(AWA)

- Design and optimization

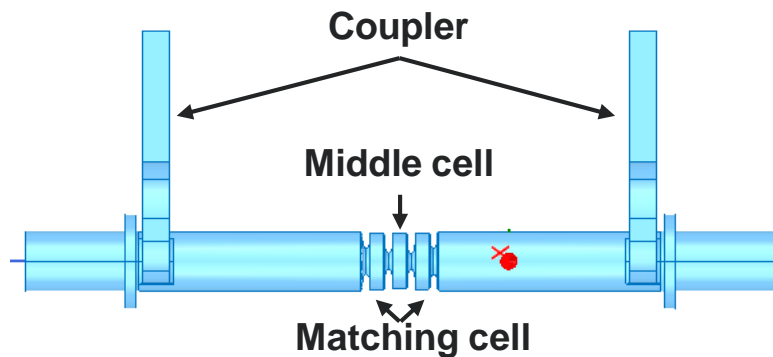

Parameters	Value	Unit
Frequency	11.7001	GHz
2a	6.1	mm
2b	20.914	mm
t	2.9	mm
Cell length	8.5411	mm
Phase advance per cell	$2\pi/3$	
Filling time	2.506	ns
Group velocity	0.0114	c
Gradient @ 500 MW input	389	MV/m
Q	6072.5	
r/Q	14047.9	Ω/m
Es/Ea	1.59	
Hs/Ea	3	mA/V
Sc/Ea ²	0.121	mA/V

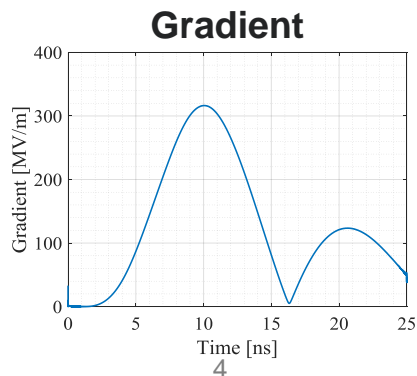
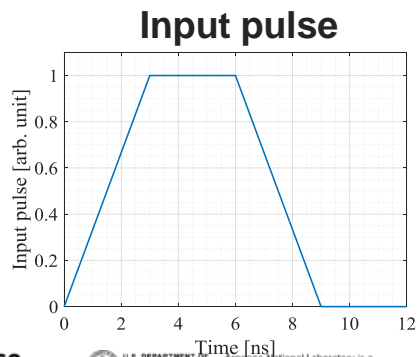

On-axis field distribution

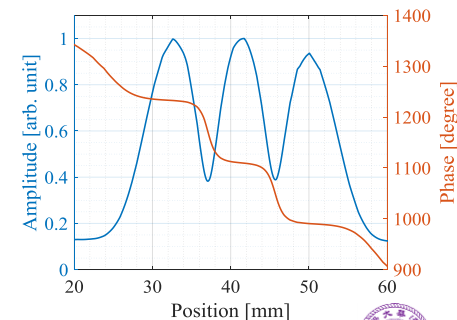

RECENT SHORT-PULSE RF BD STUDY AT AWA

- Cold test

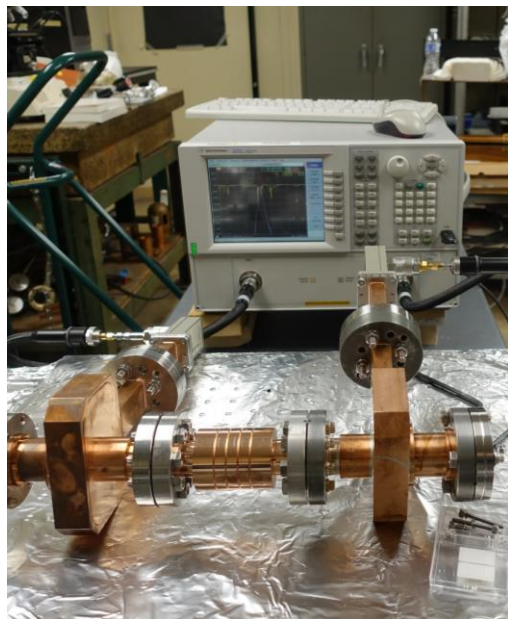

Reflection

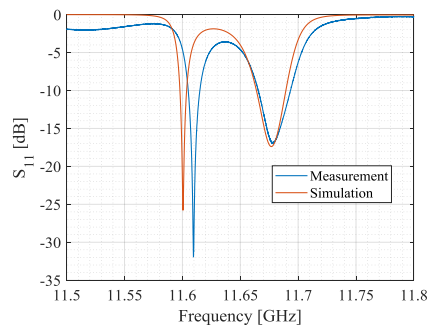

Transmission

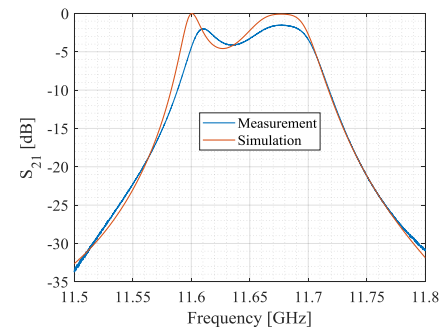

On-axis field distribution

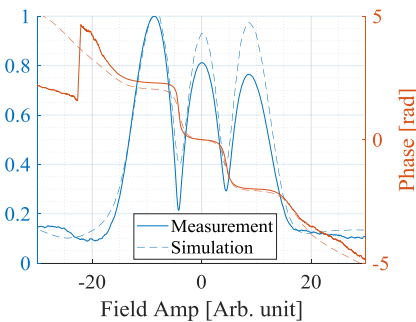

Cavity field response

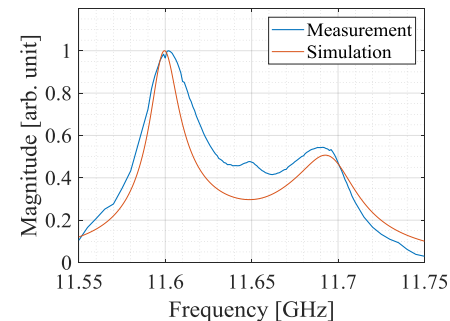

RECENT SHORT-PULSE RF BD STUDY AT AWA

- High power test

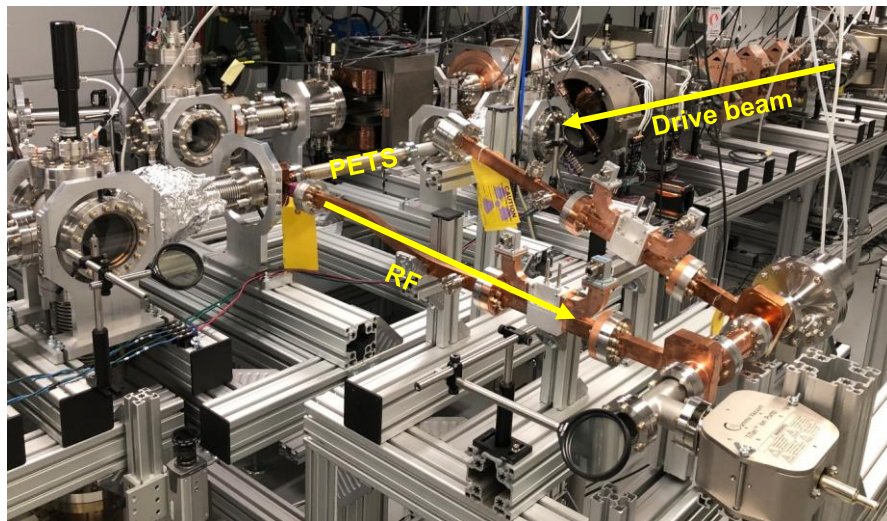

- 400 MW RF power generated from PETS with 450 nC drive beam
- **~300 MeV/m** gradient in the middle cell, **~500 MV/m** peak surface field

RECENT SHORT-PULSE RF BD STUDY AT AWA

- Preliminary breakdown study

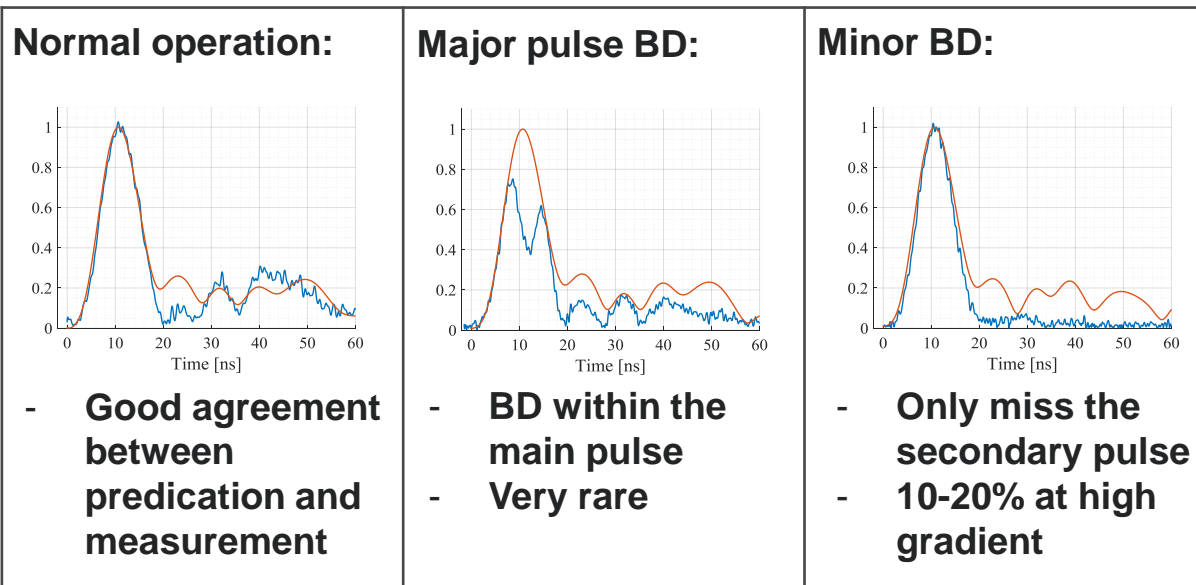
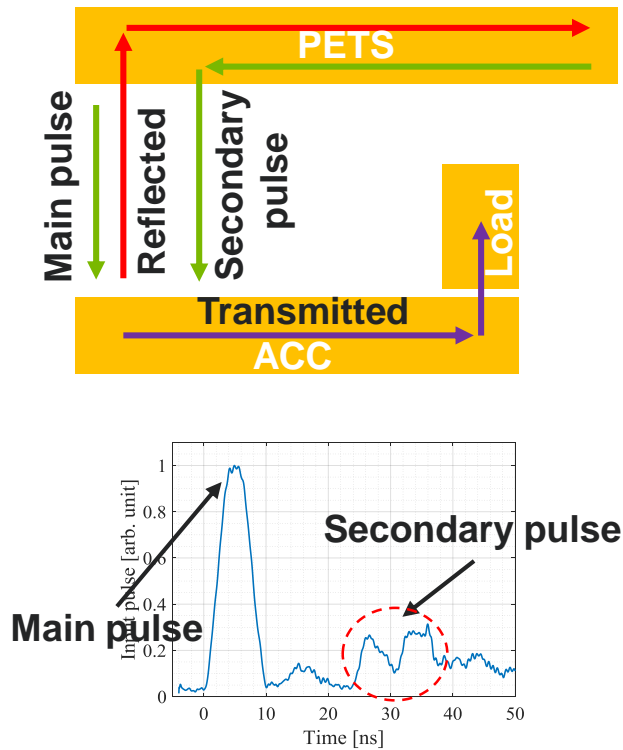

RECENT SHORT-PULSE RF BD STUDY AT AWA

Major Breakdowns



Minor Breakdowns



Ion speed in cold plasma explosion: 10^{4-5} m/s
Time to move 1 mm: at the order of 10 ns

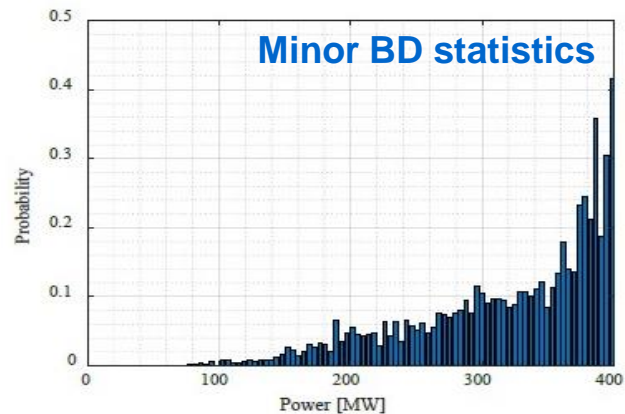
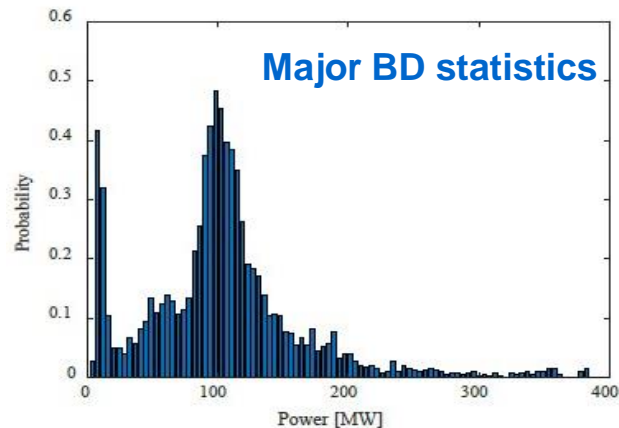

RECENT SHORT-PULSE RF BD STUDY AT AWA

- Over-coupled standing-wave gun

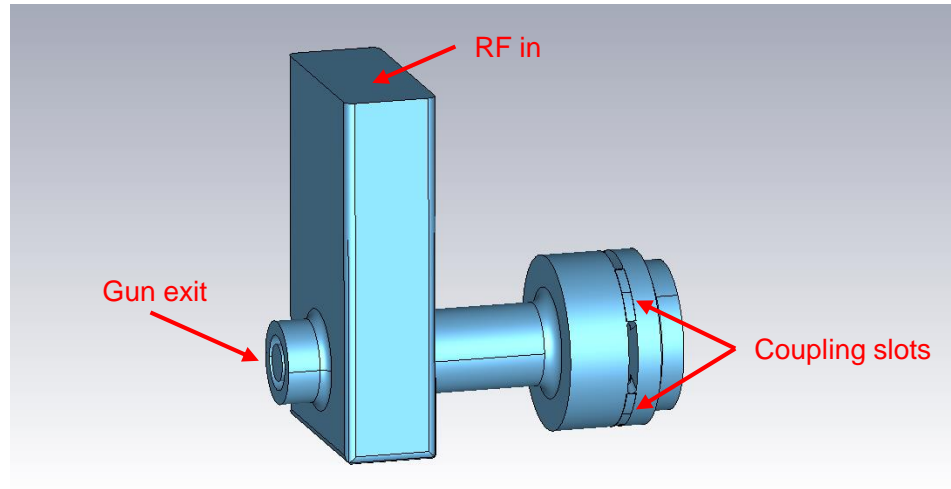

Credit to Sergey Kuzikov of Euclid Techlabs

RECENT SHORT-PULSE RF BD STUDY AT AWA

- Over-coupled standing-wave gun

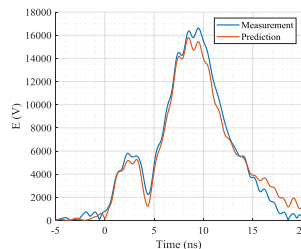
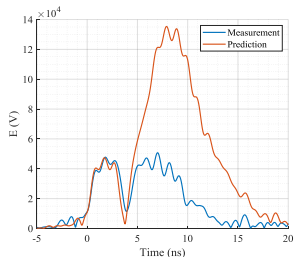
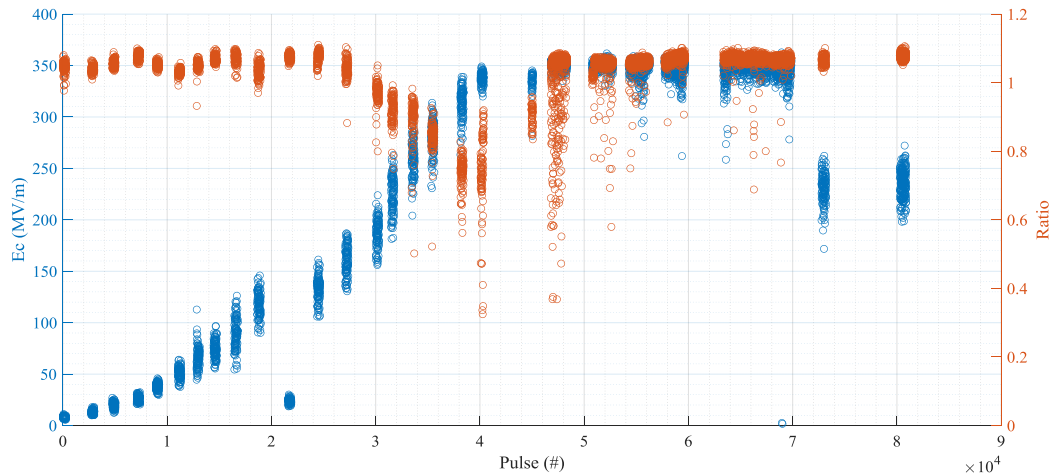

STRUCTURE R&D OF SHORT-PULSE SWFA

- Dielectric-loaded structure

- Simple geometry
- Low cost
- No surface field enhancement
- High group velocity but moderate shunt impedance

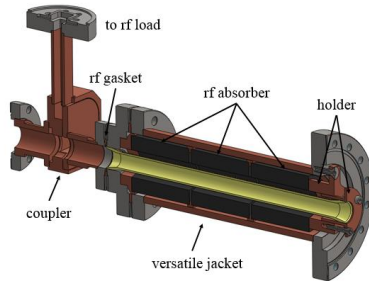

J. Shao et al, *PRAB* **23**, 011301 (2019)

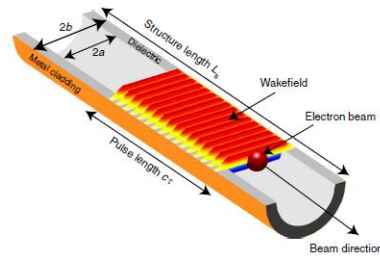

B.D. O'Shea, et al., *Nature Comm.* **7**, 12763 (2016)

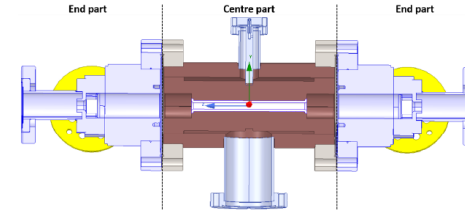

Y. Wei, et al., *arXiv* 2008.09203 (2020)

STRUCTURE R&D OF SHORT-PULSE SWFA

- Dielectric-disk structure

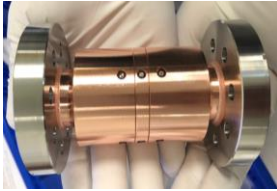
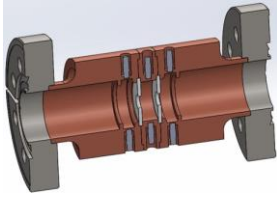

	DLA	DDA
Frequency (GHz)	26	26
ID (mm)	3	3
Group velocity	0.11 c	0.16 c
r/Q (kΩ/m)	21.8	32.5
Q	2295	6430
r (MΩ/m)	50.0	208.8
Input power (GW)	1.22	0.96
$\eta_{\text{rf-beam}}$ (%)	~9	~13
E_{max} (MV/m)	365	660

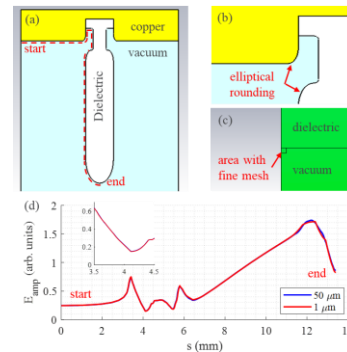
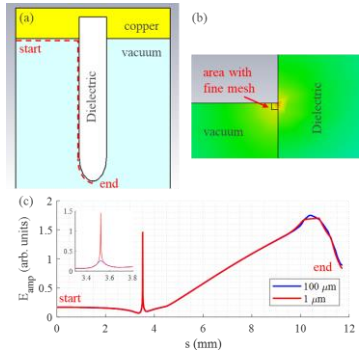

STRUCTURE R&D OF SHORT-PULSE SWFA

- Metamaterial structure

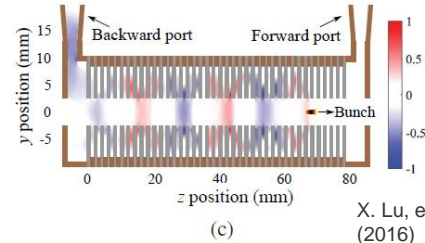
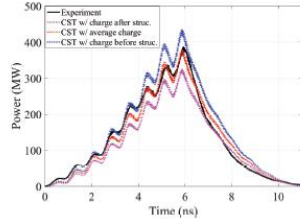
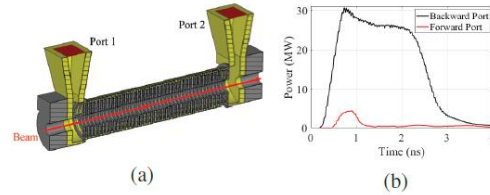
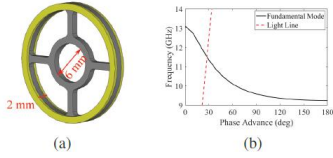

X. Lu, et al, *APL* 116, 264102 (2016)

- Other candidates

Distributed-coupling

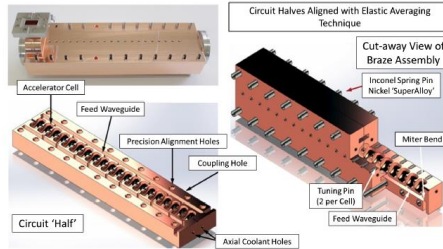

S. Tantawi, et al, *PRAB* 23, 092001 (2020)

Cryogenic temperature

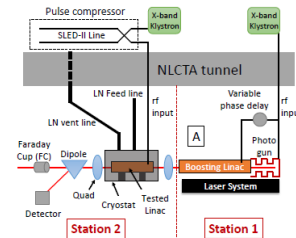

M. Nasr, et al., *arXiv* 2011.00391 (2020)

mm-wave/THz

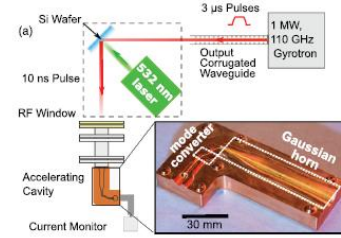

M. Othman, et al, *APL* 117, 073502 (2016)

SHORT-PULSE SWFA DEMONSTRATORS

- 500 MeV TBA demonstrator

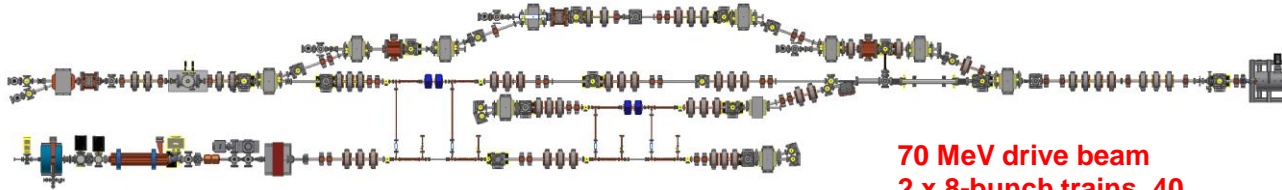

15 MeV main beam
Low charge single bunch
Accelerated to ~500 MeV

70 MeV drive beam
2 x 8-bunch trains, 40
nC/bunch
Decelerated to ~20 MeV

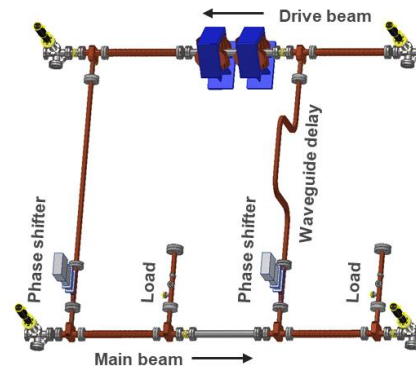
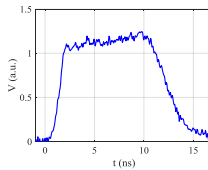

J. Shao et al, NAPAC2019

SHORT-PULSE SWFA DEMONSTRATORS

- CWA energy doubler

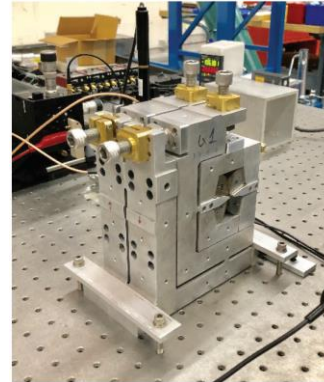
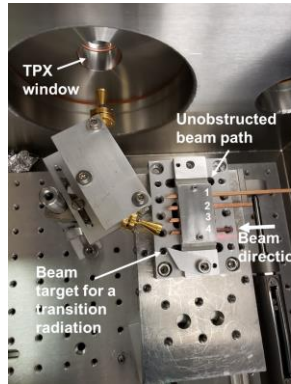
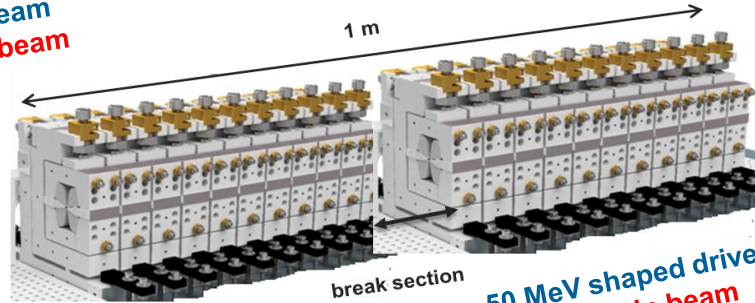
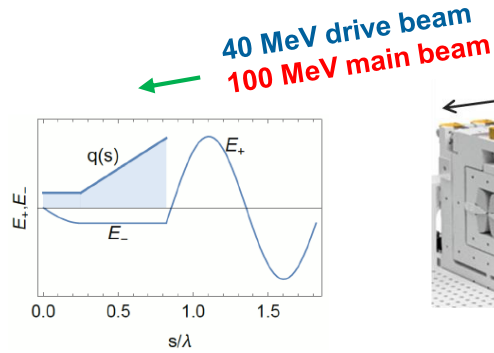

Courtesy of A. Zholents

SUMMARY

- Short-pulse structure acceleration may be a new paradigm of high gradient acceleration.
- At AWA, short RF pulses (<20 ns) are generated from power extractors driven by high charge bunch train
- Systemic study is needed to explore gradient limitation as well as to understand the breakdown physics in this regime
- Short-pulse acceleration needs advanced structure R&D for high efficiency and high gradient acceleration
- The next big step is to integrate technologies in demonstrators
- Strengthen collaboration in the SWFA community and the high gradient community