



FUTURE
CIRCULAR
COLLIDER

HZB Helmholtz
Zentrum Berlin

RF Characterization of Multilayers

Sebastian Keckert

FCC Week
July 1st, 2021

Reducing the RF surface resistance

$$R_S \approx \frac{A}{T} \omega^2 \exp\left(-\frac{\Delta}{k_B T}\right) + R_{\text{res}}$$

- New material:
Large sc energy gap Δ , large T_c
- Control residual resistance R_{res}
 - Intrinsic contribution?
 - Cooling conditions
 - Trapped magnetic field

Increasing the RF quench field

$$E_{\text{acc}} \propto B_{\text{pk}}$$

$$B_{\text{sh}} \propto B_c \propto \Delta$$

- New material:
Large superheating field B_{sh}
- Prevent early vortex penetration
 - Multilayer structures

	T_c	Δ	λ_L	ξ_0	$R_{\text{BCS}} @ 1.8 \text{ K}$	$R_{\text{BCS}} @ 4.2 \text{ K}$	max. E_{acc}
Nb	9.25 K	1.5 meV	39 nm	32 nm	3 n Ω	763 n Ω	56 MV m $^{-1}$
Nb₃Sn	18 K	3.4 meV	90 nm	7 nm	$\ll 1$ n Ω	≤ 12 n Ω	≈ 100 MV m $^{-1}$?
NbTiN	17.3 K	2.8 meV	150 - 200 nm	5 nm	$\ll 1$ n Ω	≤ 60 n Ω	≈ 100 MV m $^{-1}$?

Modify the RF penetration behavior (+ new material)

[A. Gurevich, APL 88, 012511, 2006]

- Penetration depth $\lambda \approx 30 \dots 300$ nm
 - Coatings are possible
- Thin films: $d < \lambda$
 - Distribute RF currents
- Less RF field at the substrate
 - Reduced RF losses
 - Higher quench field
- Prevents vortex avalanches
 - Stability

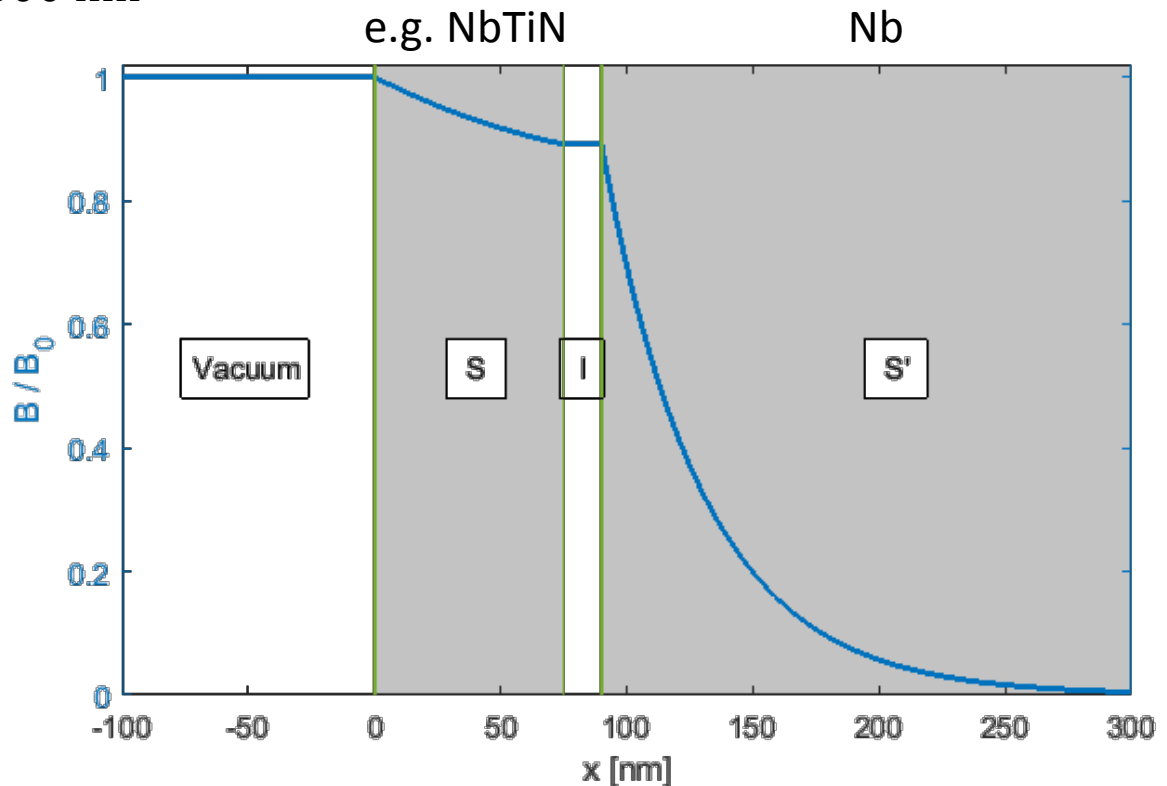

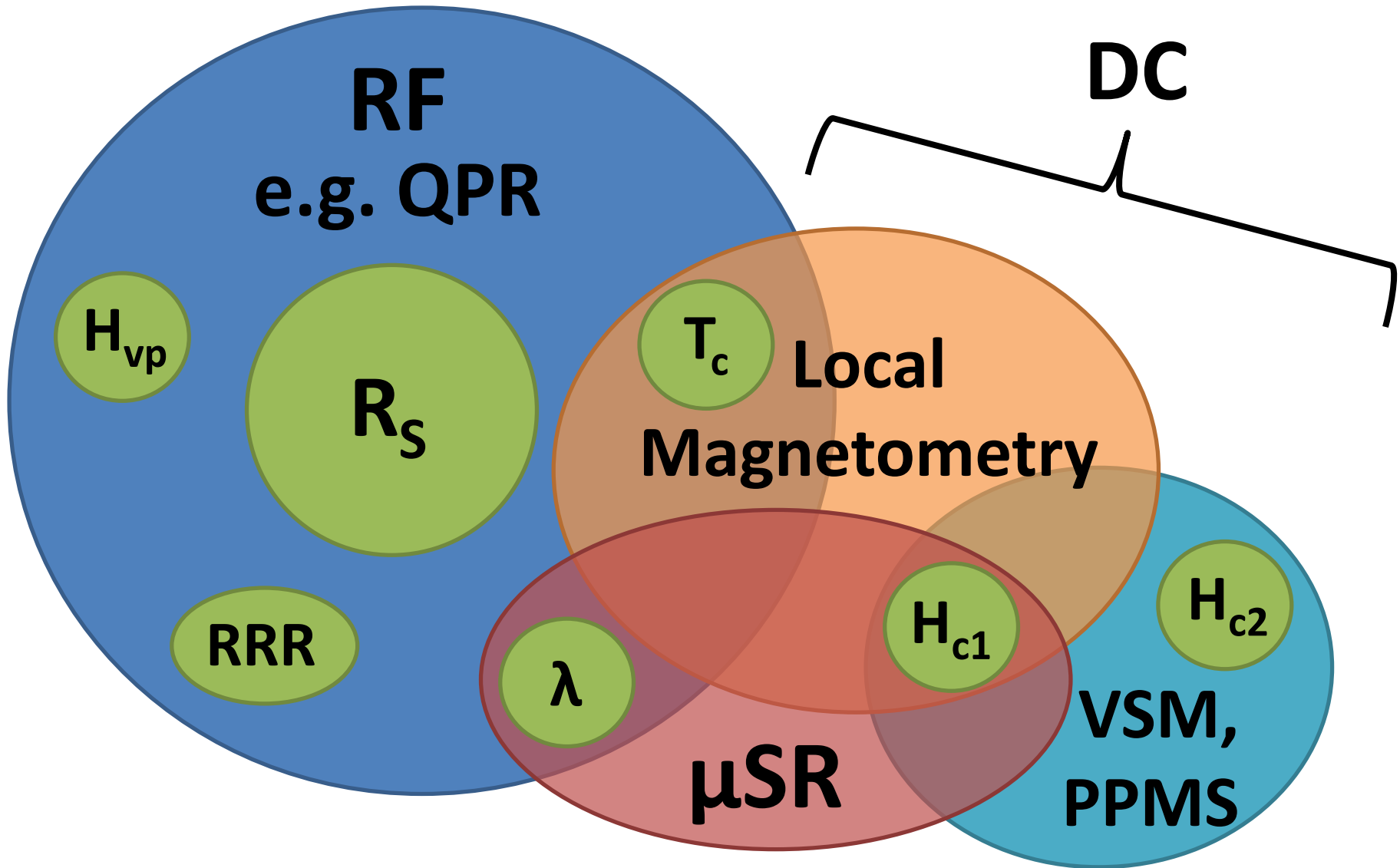

The Quadrupole Resonator (QPR)

- Quadrupole modes near 415, 845, 1285 MHz
- Operated in vertical cryostat
→ LHe bath at 1.8 K
- Coaxial structure
→ thermal decoupling
- Calorimetric measurement of surface resistance
- $B_{\text{Sample, max}} \sim 120 \text{ mT (415 MHz)}$
 $\sim 30 \text{ MV/m (TESLA)}$

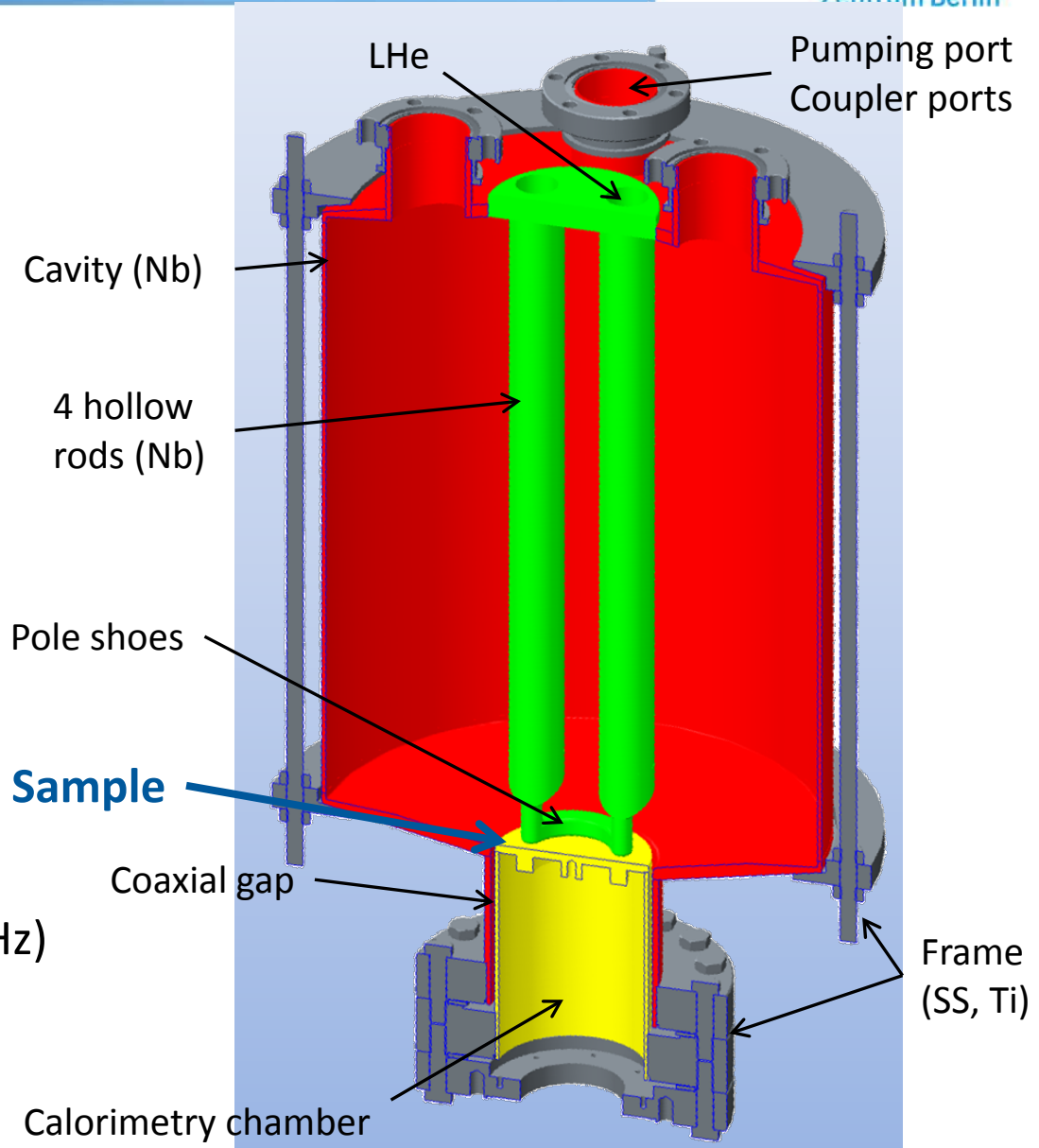

The Quadrupole Resonator (QPR)

- Quadrupole modes near 415, 845, 1286 MHz
- LHe bath at 1.8 K
- Sample thermally decoupled from cavity and LHe bath
- $B_{\text{Sample, max}} \sim 120 \text{ mT}$
 $\sim 30 \text{ MV/m (TESLA)}$

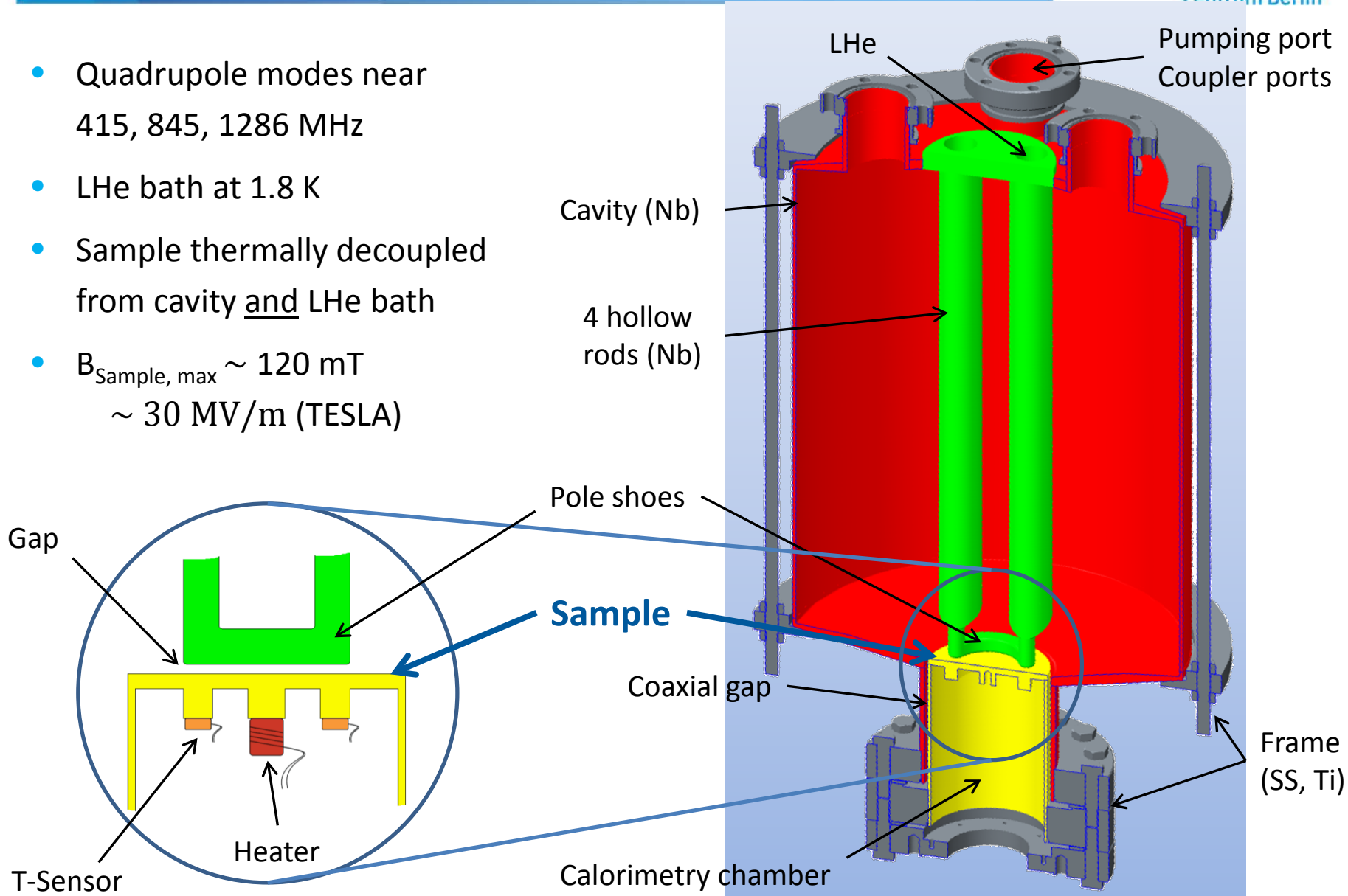

Surface resistance

- $R_S(\omega, B_{RF}, T)$
- $R_{BCS} \leftrightarrow R_{res}$
- High resolution, no reference sample needed
- Cooling conditions
- Trapped flux

Penetration depth

- Penetration depth $\lambda(T)$
- Critical temperature T_c
- NC skin depth δ

RF quench field

- $B_{vp, RF}(T, \omega)$
- T_c

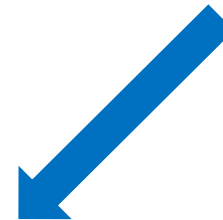
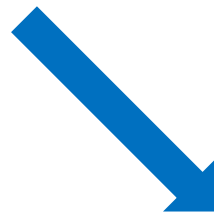

- SC parameters: Energy gap Δ , Ginzburg-Landau parameter κ
- SC critical fields: H_{c1} , H_{sh}
- Electron mean free path ℓ , residual resistivity ratio (RRR)
- NC conductivity σ

S-I-S' Sample

75 nm NbTiN – 15 nm AlN – bulk Nb

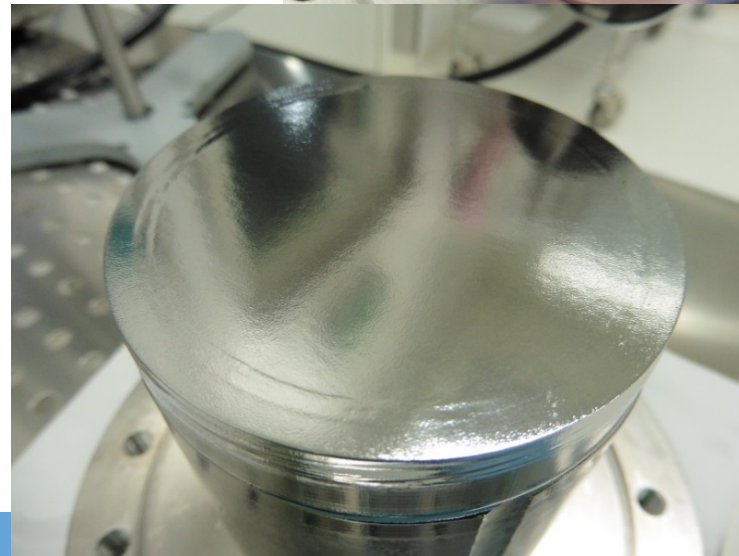
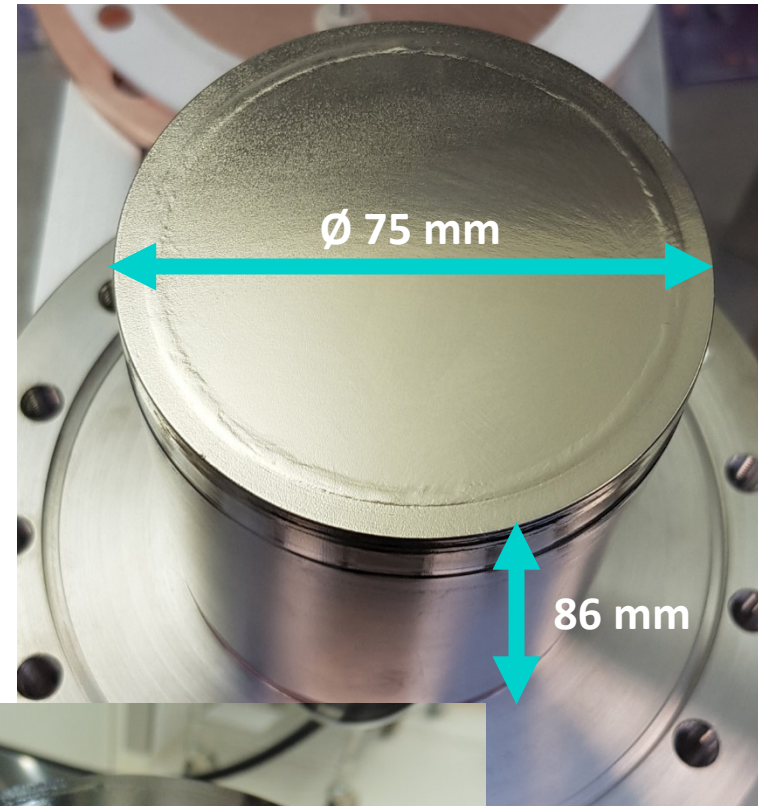
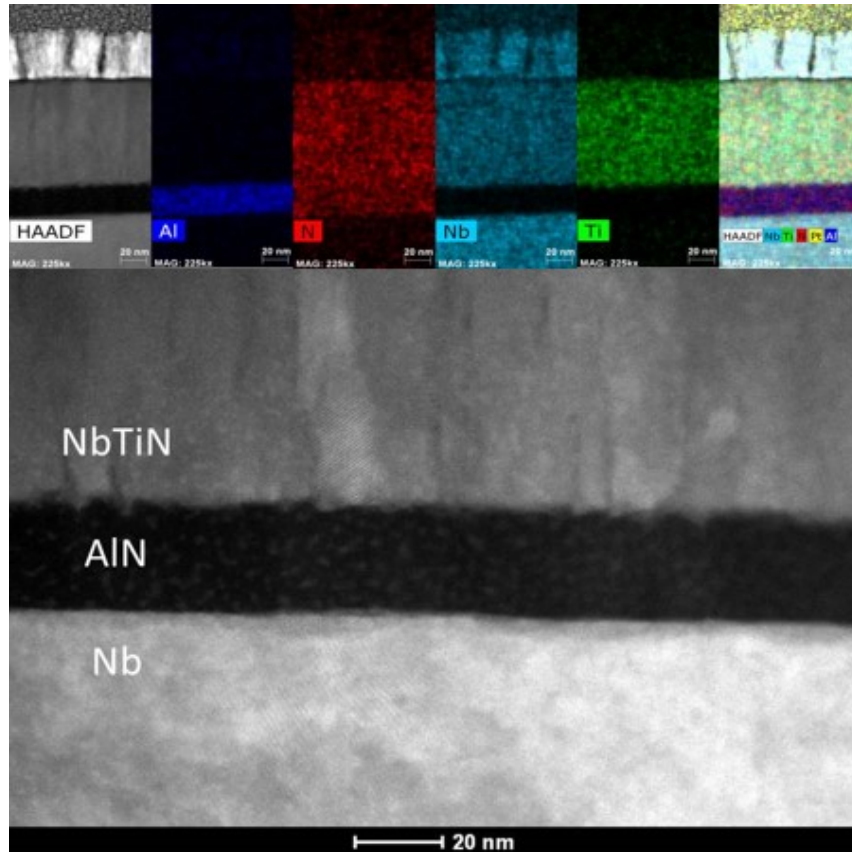

[Courtesy of Anne-Marie Valente-Feliciano]

- Simple task: Measure frequency vs. temperature

- Slater's Theorem:

$$\frac{\Delta f}{f} = \frac{\int_V^{V+\Delta V} (\epsilon_0 |E|^2 - \mu_0 |H|^2) dV}{4U}$$

$$\Rightarrow \Delta f = -\frac{\pi \mu_0 f^2}{G_{\text{Sample}}(f)} \Delta \lambda_{\text{eff}}$$

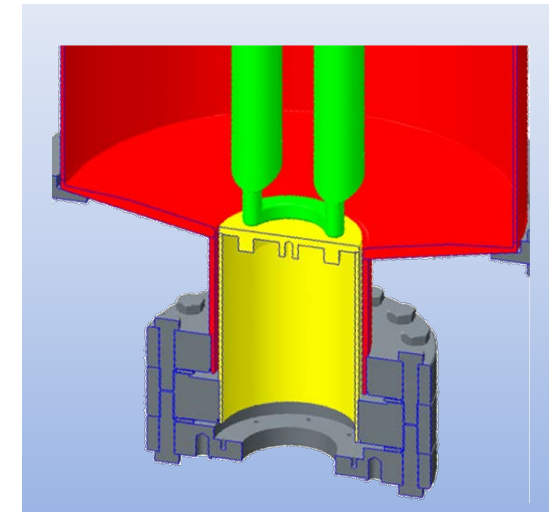

- So far: single value measurement

- What is λ of an S-I-S' structure?

$$\lambda_{\text{eff}}(T) = \frac{1}{B_0} \int_0^\infty B(x, T) dx$$

- $B(x, T)$ from multilayer theory [T. Kubo, SUST 30, 023001, 2017]

- Geometry: d_S, d_I
- Materials: $\lambda_i, T_{c,i}$

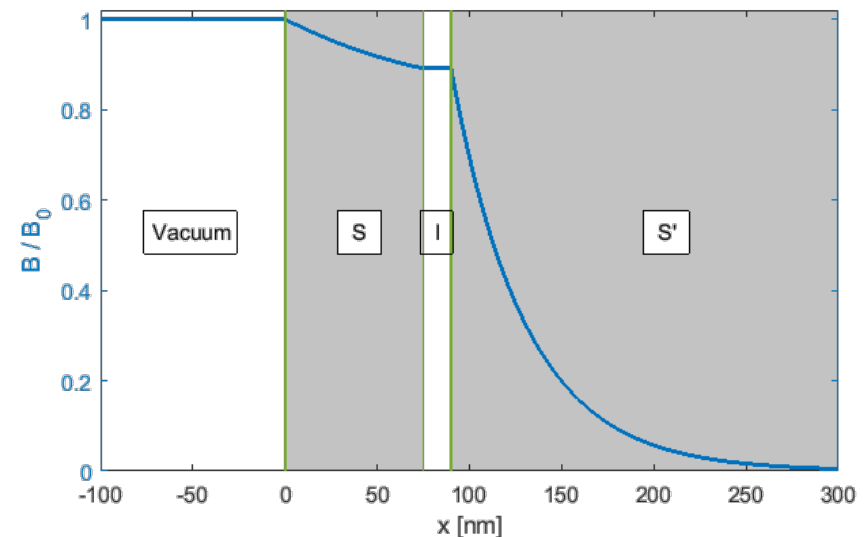

- Simple task: Measure frequency vs. temperature

- Slater's Theorem:

$$\frac{\Delta f}{f} = \frac{\int_V^{V+\Delta V} (\epsilon_0 |E|^2 - \mu_0 |H|^2) dV}{4U}$$

$$\Rightarrow \Delta f = -\frac{\pi \mu_0 f^2}{G_{\text{Sample}}(f)} \Delta \lambda_{\text{eff}}$$

- So far: single value measurement

- What is λ of an S-I-S' structure?

$$\lambda_{\text{eff}}(T) = \frac{1}{B_0} \int_0^\infty B(x, T) dx$$

- $B(x, T)$ from multilayer theory
[T. Kubo, SUST 30, 023001, 2017]

- Geometry: d_S, d_I
- Materials: $\lambda_i, T_{c,i}$

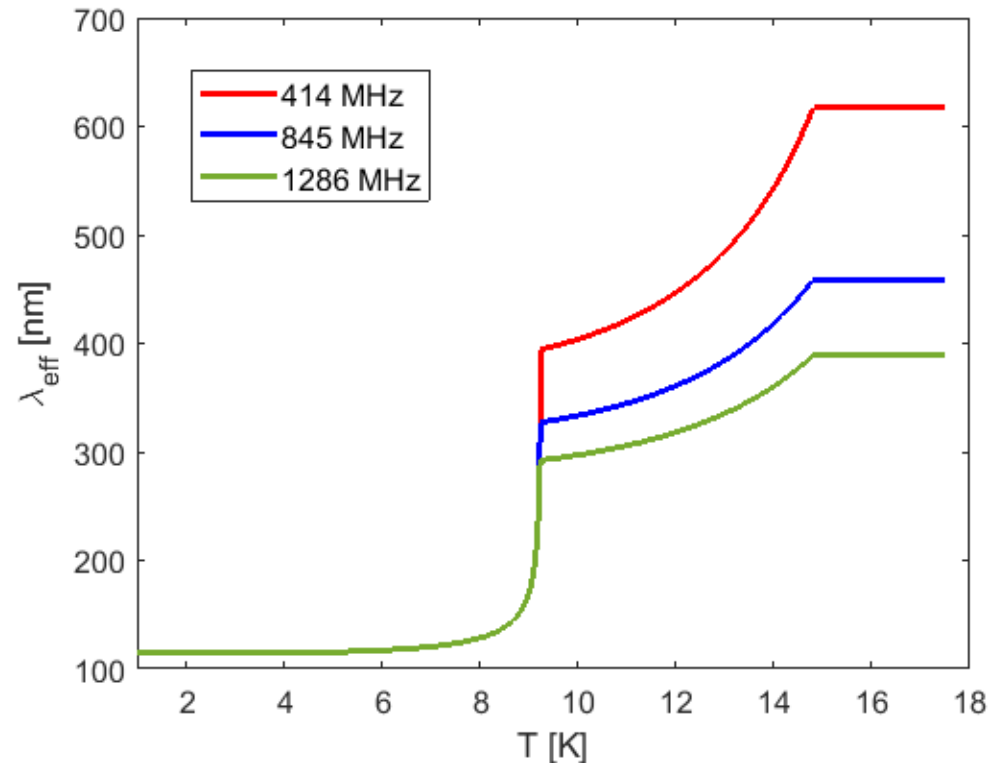

$$\lambda_{\text{eff}}(T) = \frac{1}{B_0} \int_0^\infty B(x, T) dx$$

$$\Delta f = -\frac{\pi \mu_0 f^2}{G_{\text{Sample}}(f)} \Delta \lambda_{\text{eff}}$$

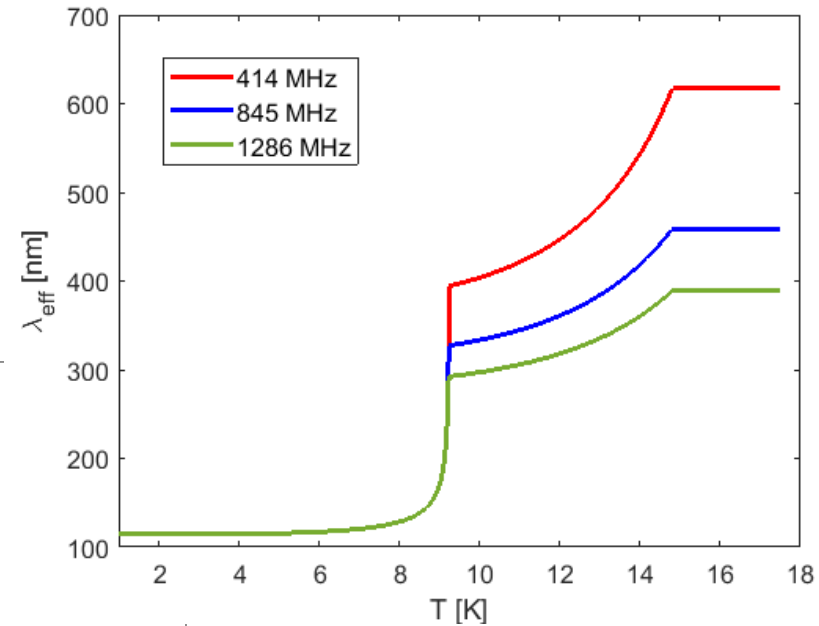
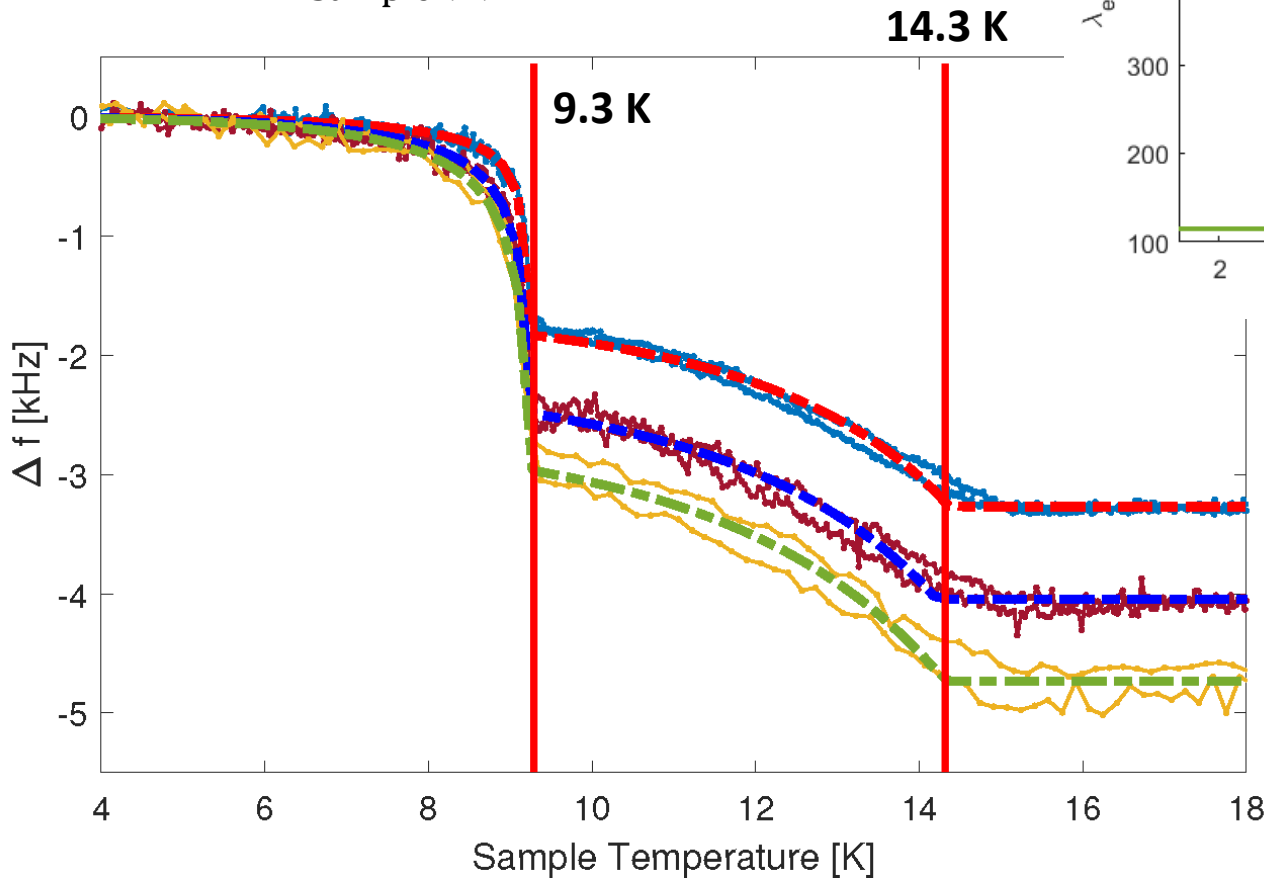

Dashed lines: Fits using **S-I-S'** multilayer theory

$$\lambda_0(l) = \lambda_L \sqrt{1 + \frac{\pi \xi_0}{2l}}$$

	Nb	NbTiN
T_c [K]	9.26	14.3 (Lit: 17.3)
λ_0 [nm]	47 ± 1	240 ... 250
RRR (sc)	17 ± 2	
RRR (nc)	320 ... 350	
ξ_0 [nm]	39	(5)
λ_L [nm]	32	(150 ... 200)
σ_{cryo} [S/m]	$(2.1 \dots 2.3) \cdot 10^9$	$2.86 \cdot 10^6$
σ_{RT} [S/m]	$6.58 \cdot 10^6$	

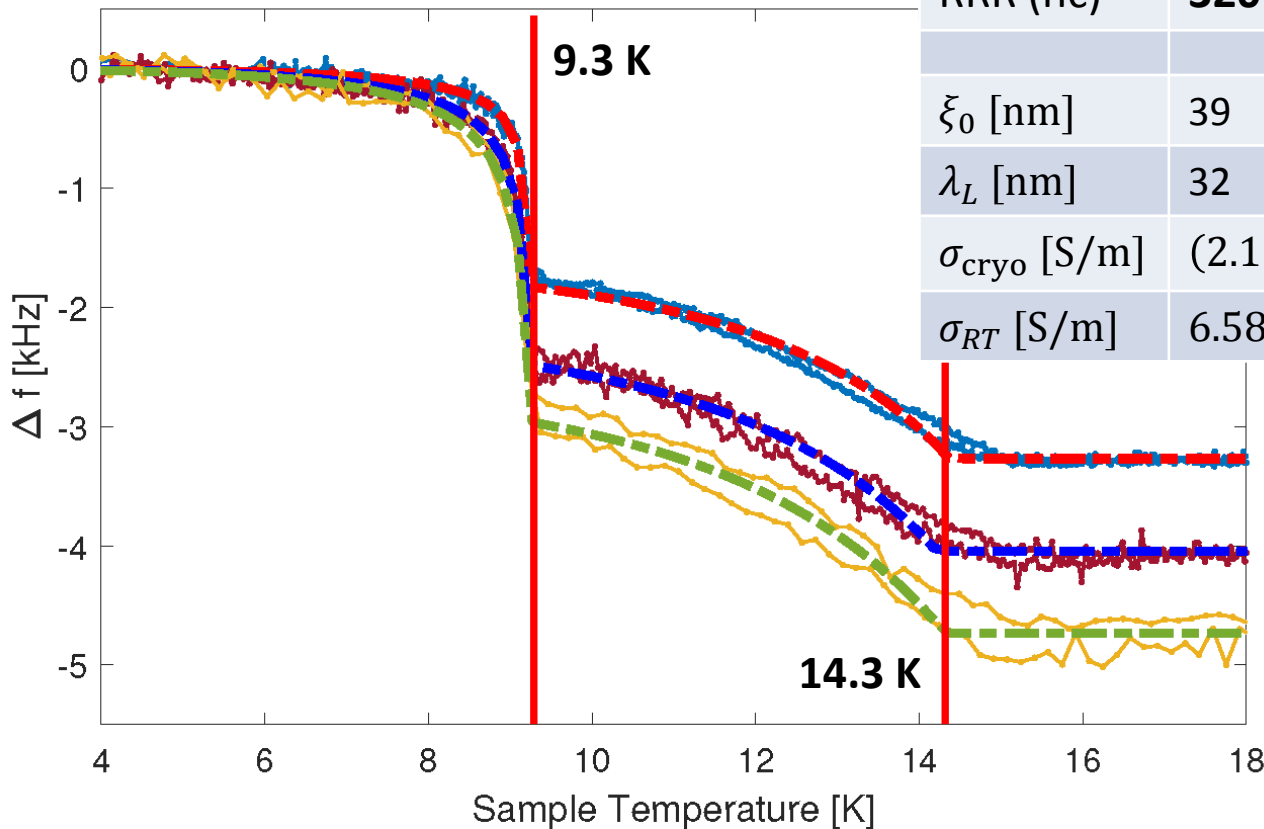

Dashed lines: Fits using S-I-S' multilayer theory

- Hard magnetic quench limit at 20-25 mT
- **Fit** according to S-I-S' multilayer theory

	Nb	NbTiN
T_c [K]	9.3	14.3 (Lit: 17.3)
B_{max} [mT]	220 ... 250	17 (Lit: ≥ 200)

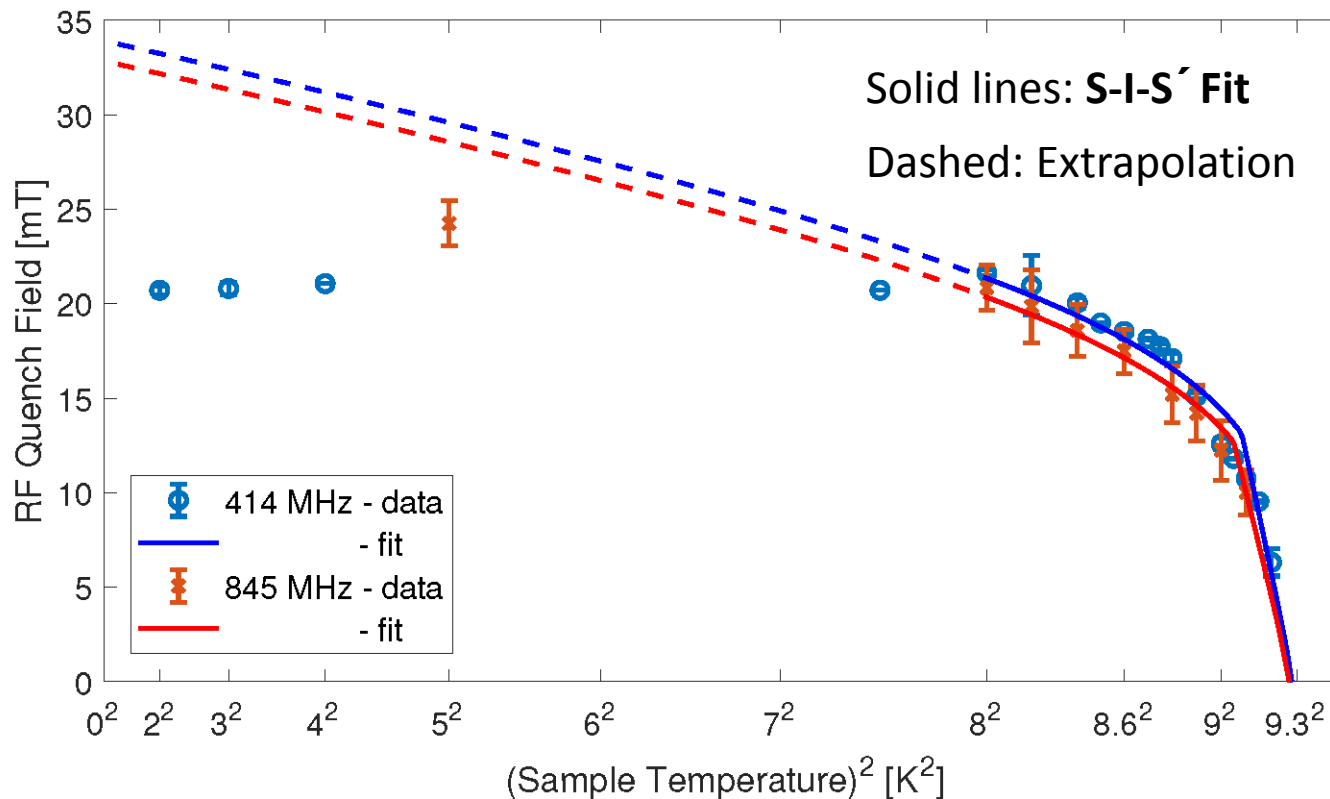

- Hard magnetic quench limit at 20-25 mT
- **Fit** according to S-I-S' multilayer theory

	Nb	NbTiN
T_c [K]	9.3	14.3 (Lit: 17.3)
B_{max} [mT]	220 ... 250	17 (Lit: ≥ 200)

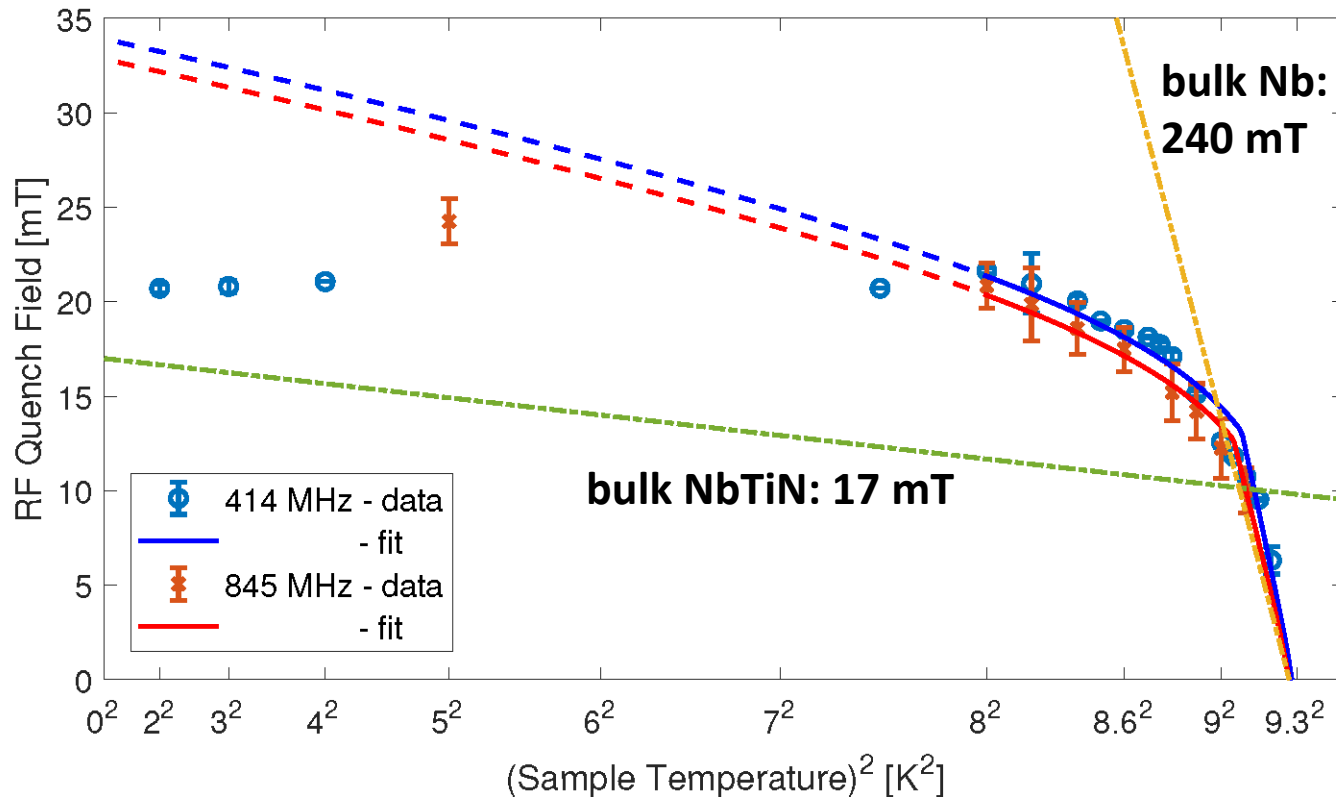

- $R_S(T)$ at constant B_{RF}
 - Q1, Q2: 10 mT
 - Q3: 8.8 mT

→ Non-monotonic $R_S(T)$

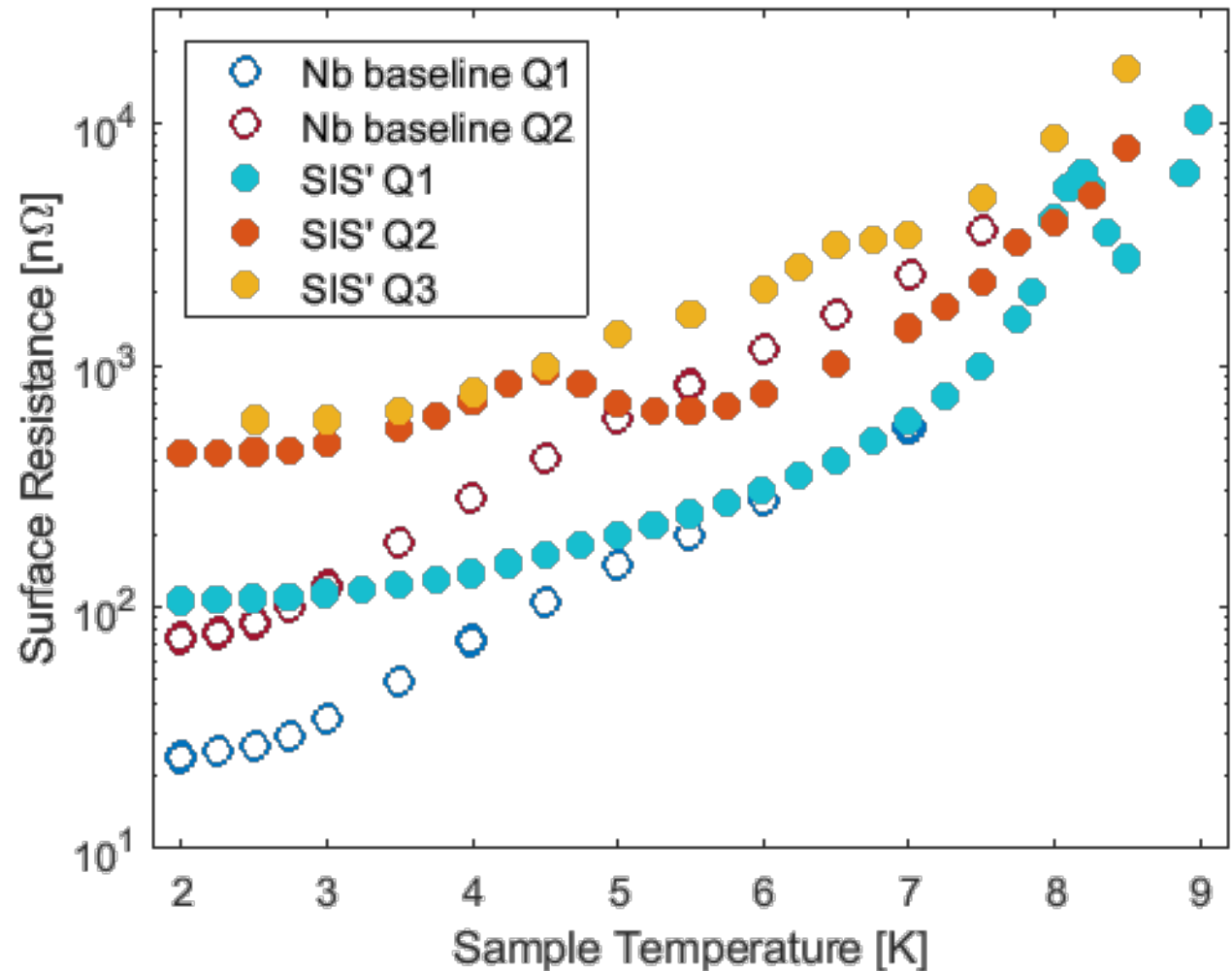

- $R_S(T)$ at constant B_{RF}
 - Q1, Q2: 10 mT
 - Q3: 8.8 mT

→ Non-monotonic $R_S(T)$

- Expectation:
Weighted sum of R_{BCS}

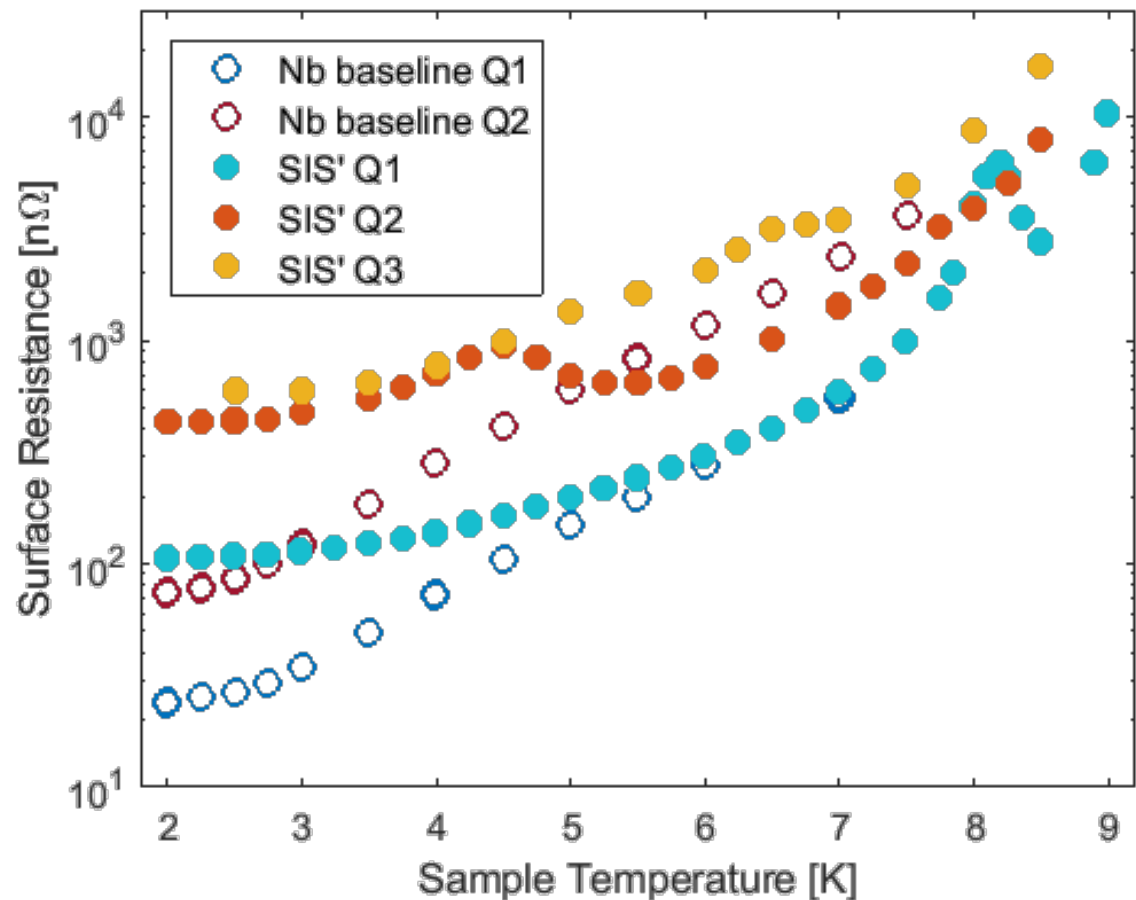
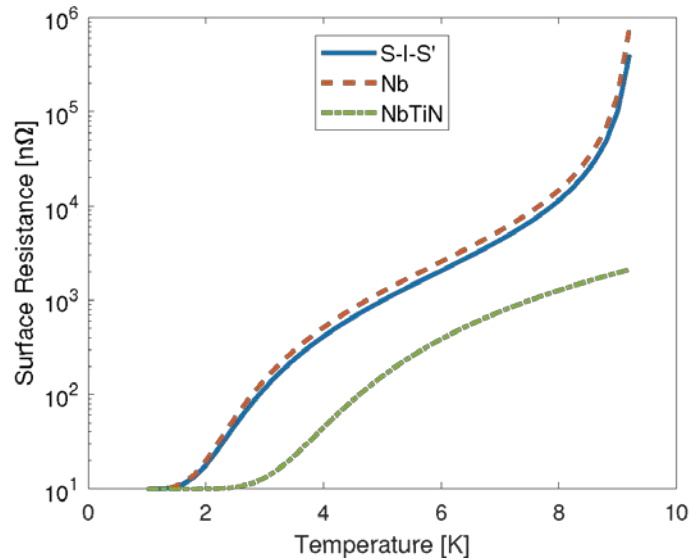

- $R_S(T, B_{RF})$ at Q2 (845 MHz)

→ Non-monotonic $R_S(T)$

→ $R_S(B)$ depends on temperature

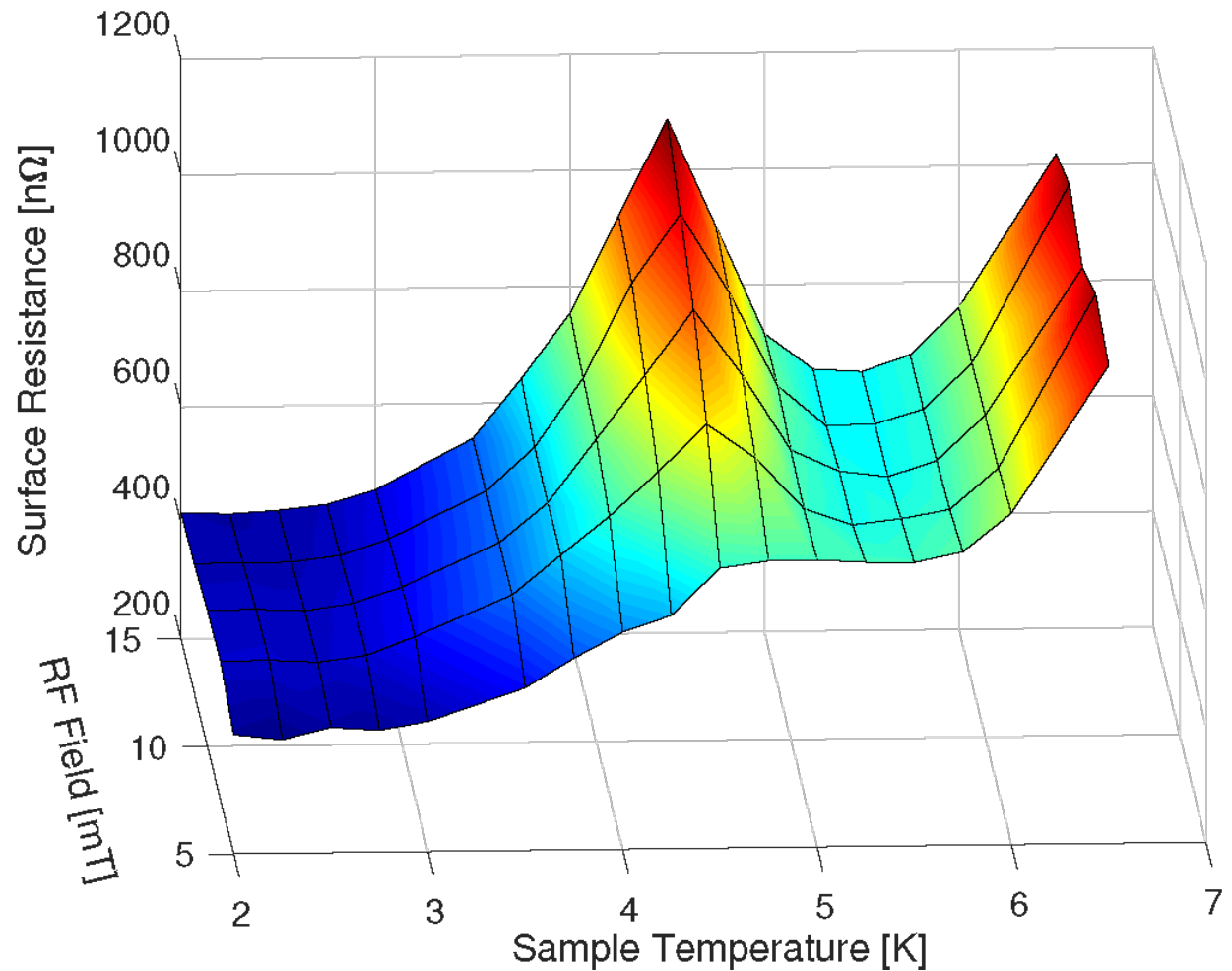

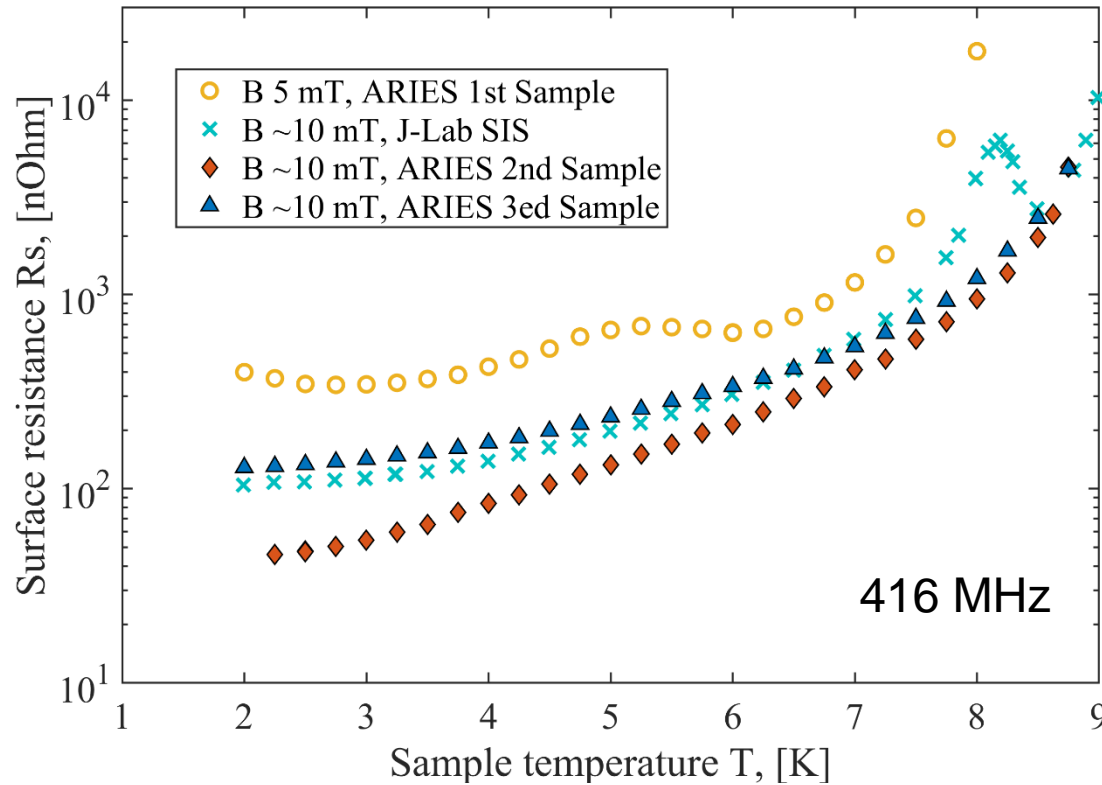

- So far: Not much emphasis on the insulator layer
- But: A thicker insulator layer leads to higher losses!

D. Tikhonov, SRF'21, SUPFDV006, <https://indico.frib.msu.edu/event/38/>

	SIS films tested	Method	Structure	Produced by
J-Lab SIS	NbTiN – AlN – Nb(bulk)	DC MS	75nm – 15 nm – bulk Nb	J-lab 2018
ARIES 1st SIS	NbN – AlN – Nb(film)/Cu	DC MS	197nm – 35 nm – 3 μm Nb	Siegen 2020
ARIES 2nd SIS	NbN – AlN – Nb(film)/Cu	HiPIMS	180nm – 8 nm – 4 μm Nb	Siegen 2021
ARIES 3rd SIS	NbN – AlN – Nb(film)/Cu	HiPIMS	180nm – 24 nm – 4 μm Nb	Siegen 2021

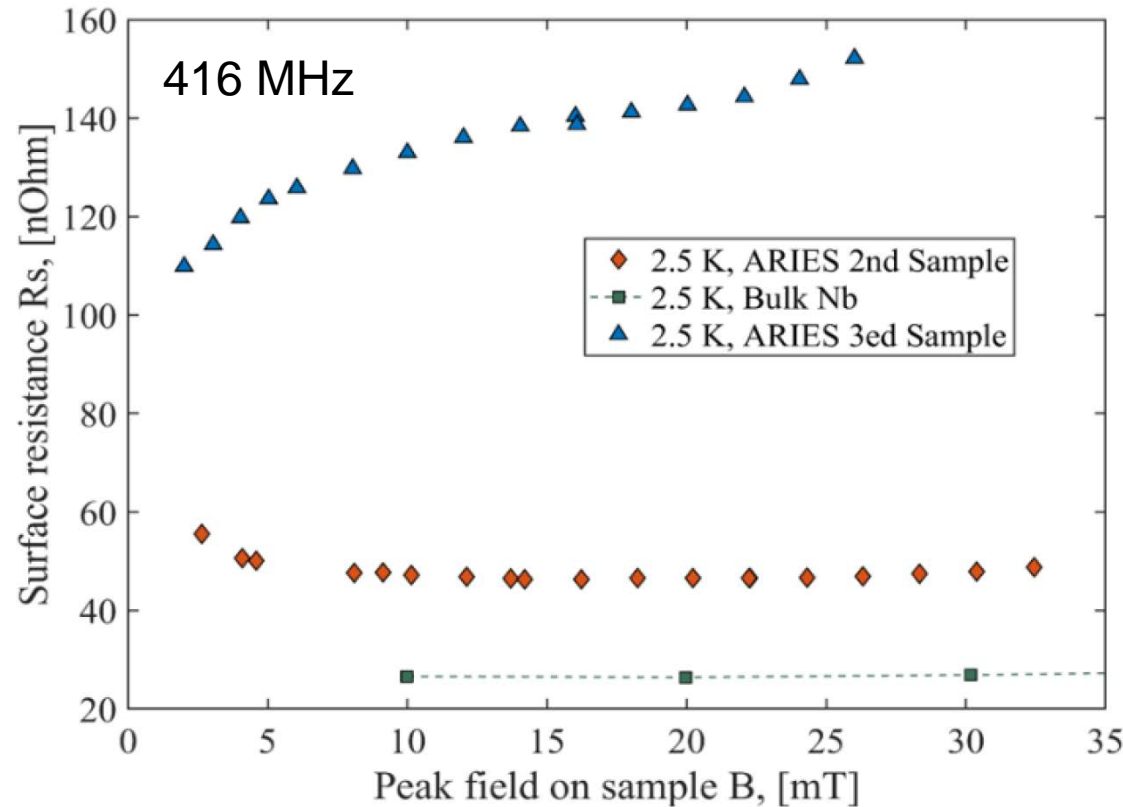

- Earlier samples showed strong Q-slope already at low fields
- Performance still limited by early quenches

D. Tikhonov, SRF'21, SUPFDV006, <https://indico.frib.msu.edu/event/38/>

	SIS films tested	Method	Structure	Produced by
ARIES 2nd SIS	NbN – AlN – Nb(film)/Cu	HiPIMS	180nm – 8 nm – 4 μm Nb	Siegen 2021
ARIES 3rd SIS	NbN – AlN – Nb(film)/Cu	HiPIMS	180nm – 24 nm – 4 μm Nb	Siegen 2021

SRF characterization of multilayers using a Quadrupole Resonator (QPR)

- Large parameter space available (f, T, B)
- Penetration depth measurement consistent with S-I-S' multilayer theory
 - Confirms RF current distribution
- RF critical field
 - Rather low quench limits so far
 - Non-quadratic behavior as expected
- Surface resistance
 - Non-monotonic $R_s(T)$ observed
 - R_s increases with insulator thickness

Thank you for your attention!

