



This project has received funding from the European Union's Horizon 2020 research and innovation programme under grant agreement No 951754.

FCC-EE & HH CRYOGENIC SYSTEM CONCEPTUAL DESIGN STATUS & PERSPECTIVES

L. Delprat, K. Brodzinski (CERN/TE-CRG)

Based on the work of L. Taviani (CERN/ATS-DO)

With all input data from FCC CDR published in January 2019



Table of content

Introduction

Presentation and context 3

Current status of the study

Civil engineering 4

FCC-ee conceptual design 5

FCC-hh conceptual design 12

Organization of the cryogenics work

FCC study phase II organization and
CERN cryogenics group involvement 17

Objectives for the 2nd study phase ('21-'25)

Main deliverables & overall timeline 18

Conclusion

Next steps 19

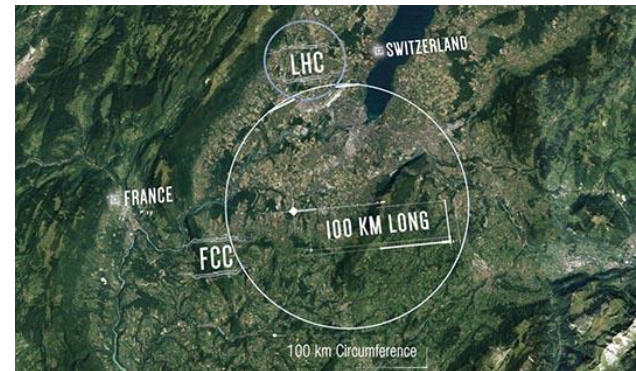
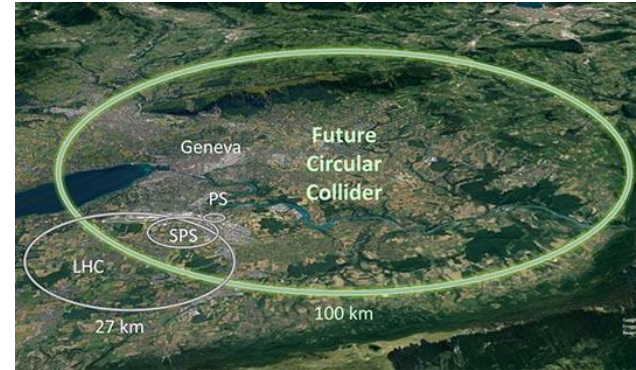

Introduction

Presentation and context

- 2013 update of ESPP officially launching the FCC study, with the mandate of delivering a Conceptual Design Report for HE-LHC, FCC-ee, FCC-hh
- L. Tavian (CERN/ATS-DO) as responsible for the cryogenic systems study
- Conceptual Design Report (CDR) published in January 2019, ending Study Phase I
- Now entering Study Phase II (2021-2025), involving the CERN Cryogenics Group (TE-CRG), with the aim of issuing a Feasibility Study Report by 2025

Current status of the study

Courtesy F. Valchkova

Civil engineering

- Quasi-circular tunnel, diameter 5.5 m, depth \approx 300 m, tilt $<$ 1%
- Arc segments & straight sections
- Circumference of **97.75 km**
- **12 new surface sites**

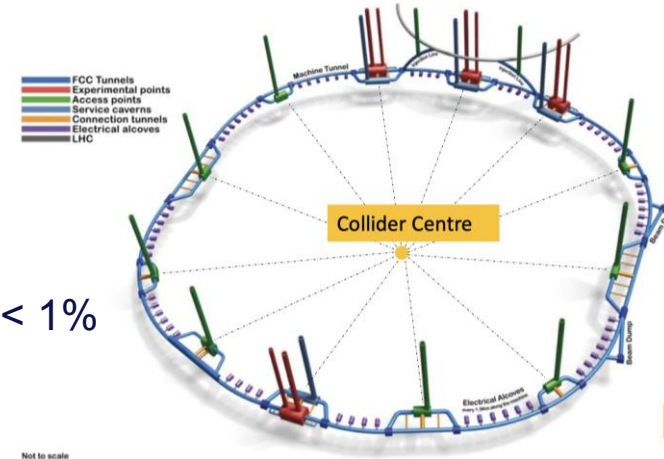

Not to scale

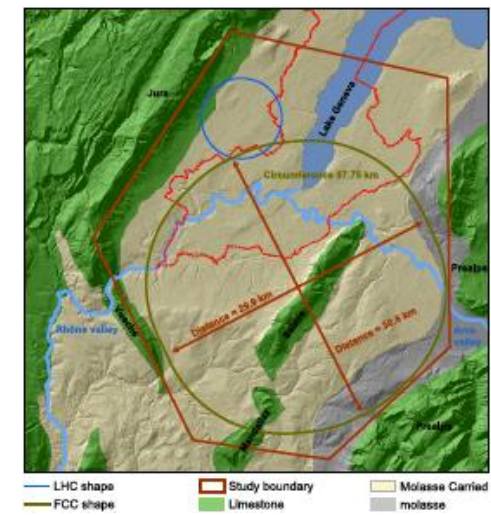
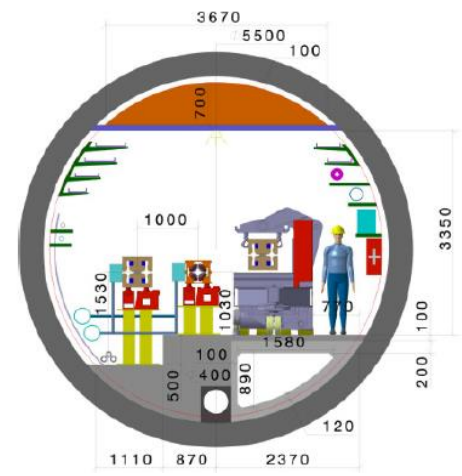

FCC-ee conceptual design

Main considerations

- FCC-ee is designed for 4 physics working points:
 - Z, W, H and ttbar1 & 2
- Staging of these 4 machines requires a gradual increase of the number of SRF modules (as well as the accelerating frequency), hence a staging of the cryogenic system
- 400 MHz SRF cavities to be operated in LHe_(sat) bath @ 1.3 bar / 4.5 K
- 800 MHz SRF cavities to be operated in LHe_(sat) bath @ 30 mbar / 2 K

FCC-ee conceptual design

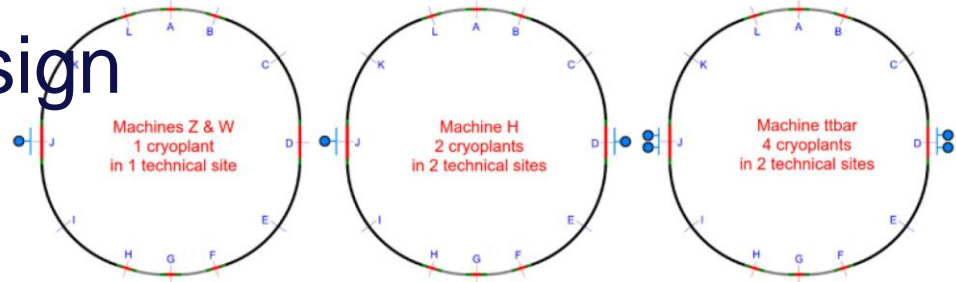

General layout of the cryogenic system

- Refrigeration plants wrt machine
 - Z, W: 1 cryoplant
 - H: 2 cryoplants
 - ttbar: 4 cryoplants
- Technical sites wrt machine
 - Z, W: 1 technical site
 - H, ttbar: 2 technical sites
- SRF straight sections in PD & PJ
 - Each of them **1.4 km long** i.e. cryogenic distribution on the equivalent length
 - “Staging” of the QRL (see next slide)

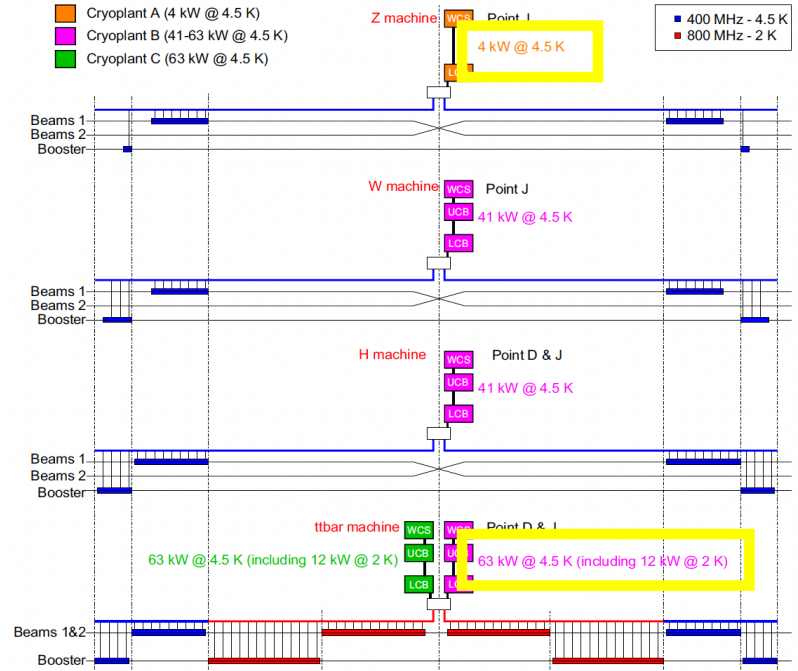

FCC-ee conceptual design

Cryogenic distribution line

- Machines Z, W, H
 - 4 internal lines (C, D, E, F)
 - DN650
- Machines ttbar
 - +2 internal lines for 30 mbar pumping of 800 MHz cavities = 6 internal lines in total
 - DN850

Component	Diameter (mm)
Line A	50
Line B	300
Line C	100
Line D	200
Line E	80
Line F	80
Vacuum jacket 400 MHz cryomodules	550*
Vacuum jacket 800 MHz cryomodules	750*

*+100 mm for bellows and flanges.

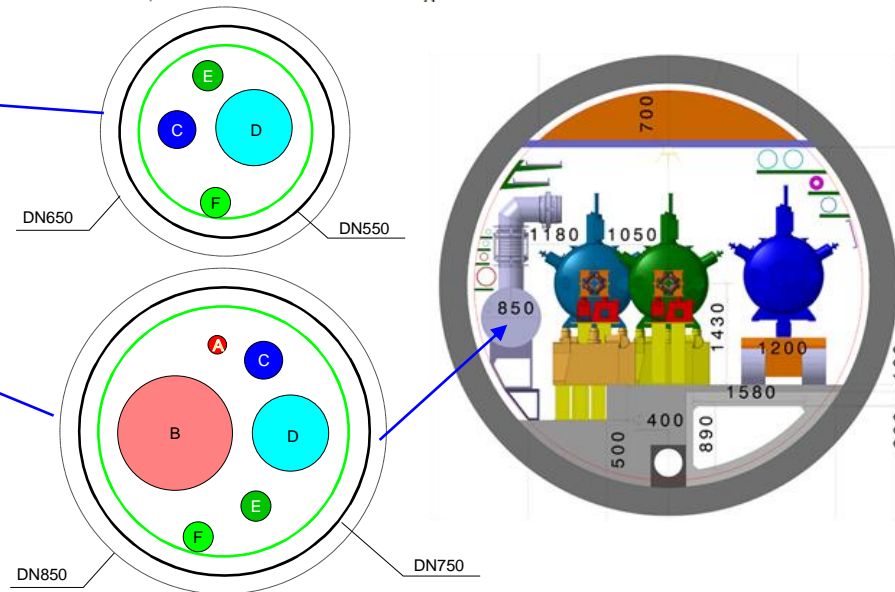

FCC-ee conceptual design

Temperature levels

- **50 – 75 K** for the thermal shield as major heat intercept
- **4.5 K** normal saturated helium for the cooling of 400 MHz SRF cavities
- **2 K** superfluid saturated helium for the cooling of 800 MHz SRF cavities

Steady-state heat loads in FCC-ee

	Z		WW		Machine ZH		tt1 (tt2)			
	Per beam	Boost.	Per beam	Boost.	Per beam	Boost.	2 beams	Boost.	2 beams	Boost.
Frequency	400 MHz									
Temperature	4.5 K								800 MHz	
# cells / cavity	1	4	4		4		4		5	
# cavities	52	12	52	52	136	136	272	136	296 (372)	400 (480)
# cryomodules	13	3	13	13	34	34	68	34	74 (93)	100 (120)
Dynamic losses / cav [W]	14	11	210	26	202	29	210	30	66	10
Static losses / cav [W]	8		8		8		8		8	

(nominal conditions)

Nominal cooling capacity per cryoplant

Working point	50–75 K (kW)	4.5 K (kW)	2 K (kW)	Cryoplant size (kWeq @ 4.5 K)	No. of cryoplants (-)
Z	5.5	3.7		4	1
WW	6.4	32		33	1
ZH	7.1	41		41	2
tt1	6.6	21	10	55	4
tt2	7.6	21	12	63	4

(incl. operational margin factor of 1.3)

FCC-ee conceptual design

Cryoplants staging scenario

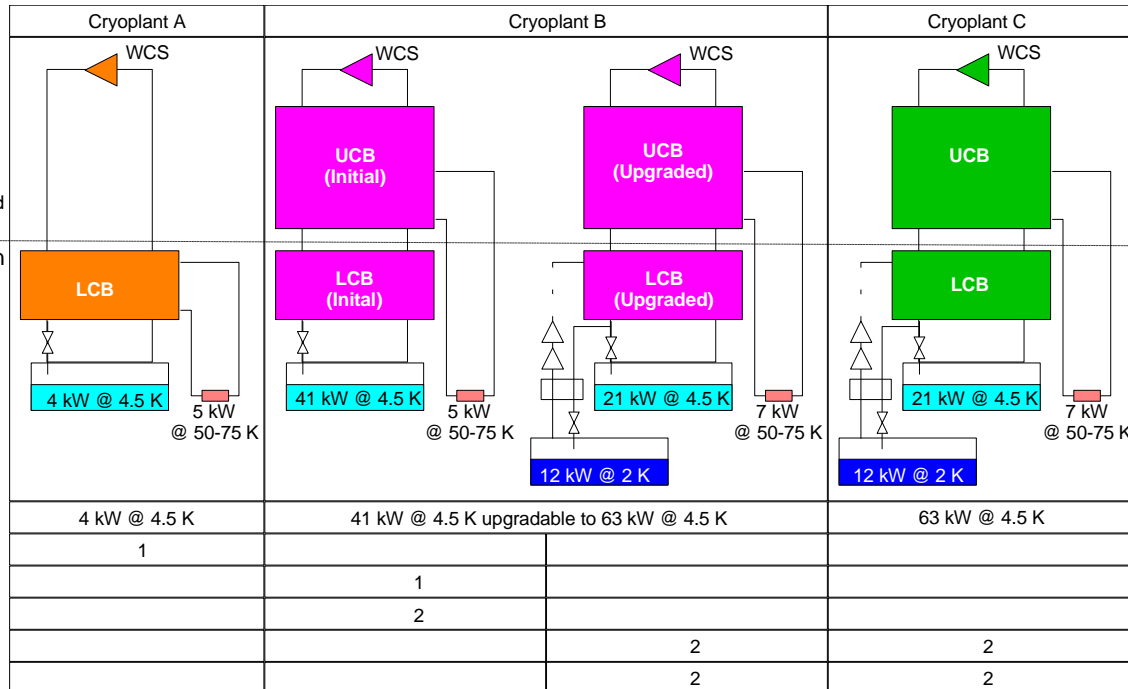

Staging scenario similar to LEP-LHC:

- started with two 6 kW plants
- then four 12-18 kW plants (LEP2 – LEP2+); upgraded with 2.4 kW @ 1.8 K units for LHC
- then four additional 18 kW including 1.8 K units for LHC

FCC-ee conceptual design

Cryogenic flow scheme of FCC-ee cryomodules

- 400 MHz cavities located at the far end of the straight sections
- 800 MHz cavities located close to the 2 K pumping units (machines ttbar)

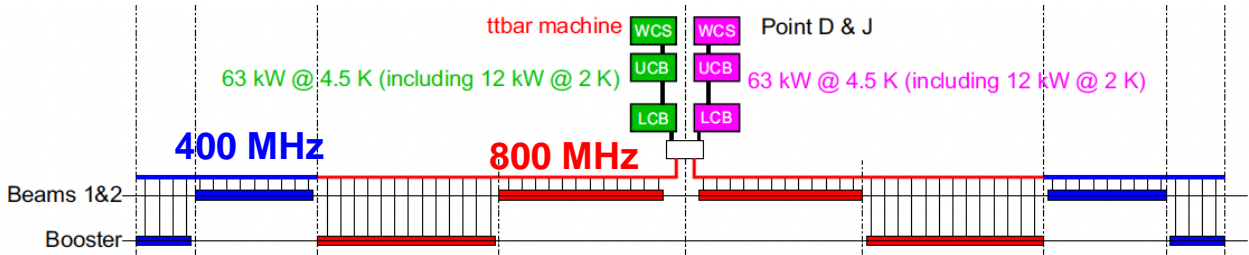
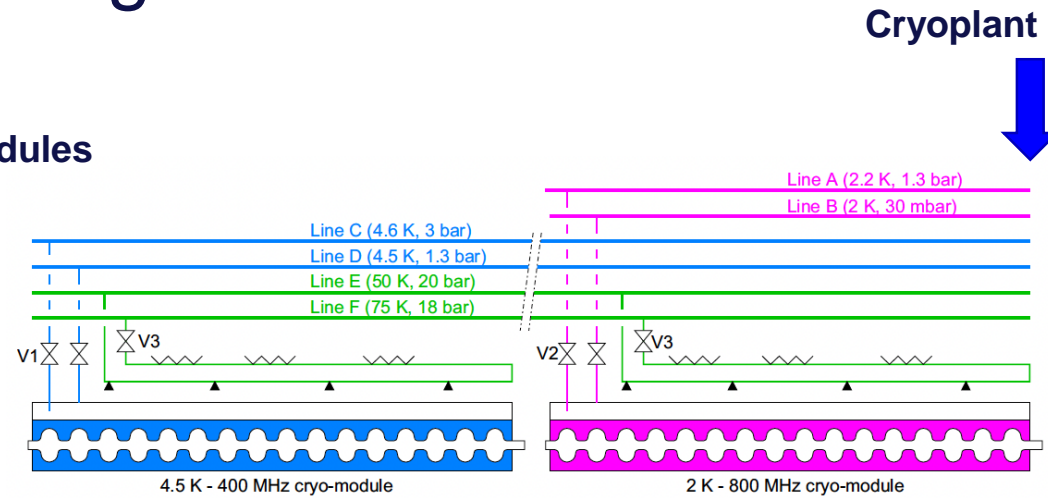

FCC-ee conceptual design

Helium inventory and electrical consumption

- **Total helium inventory of ≈ 26 t** for ttbar machines (40 kg of He per cryomodule)
- Required electrical power varies
 - from 1 MW for the Z machine
 - to **50 MW for ttbar2 machine**

Machine	Z	WW	ZH	tt1	tt2
Cryomodules (t)	1.2	1.6	4.1	11.0	12.6
Distribution (t)	3.9	3.9	7.9	8.9	8.9
Cryoplant (t)	1	1	2	4	4
Total (t)	6	7	14	26	26
Number of 250 m ³ MP storage tanks	8	8	18	30	32

Working point	Installed power (MW)			Nominal power (MW)		
	Per plant	Per site	Total	Per plant	Per site	Total
Z	0.9	0.9	0.9	0.8	0.8	0.8
WW	9.5	9.5	9.5	7.1	7.1	7.1
ZH	9.5	9.5	19	8.3	8.3	17
tt1	14	29	58	12	23	46
tt2	14	29	58	13	25	50

- 250 m³ medium-pressure (20 bar) storage tanks located in PD & PJ



FCC-hh conceptual design

Main project decisions

- Ultimate conditions:

- Beam energy 100 TeV c.m.
- Bunch current 1×10^{11} ppb

⇒ Operational margin for the cryogenic system given by either of the following conditions:

- ⇒ Beam energy ultimate with bunch population reduced by 25%
- ⇒ Beam energy -5% with bunch population -10%
- ⇒ Beam energy -7.5% with bunch population ultimate

FCC-hh conceptual design

General layout of the cryogenic system

- 10 refrigeration plants

- One helium refrigerator
- One 1.8 K refrigeration unit
- One neon-helium refrigerator

- 6 technical sites

- Short sectors (5 km)

- Long sectors (10 km)

- Cryogenic distribution line components larger than for FCC-ee

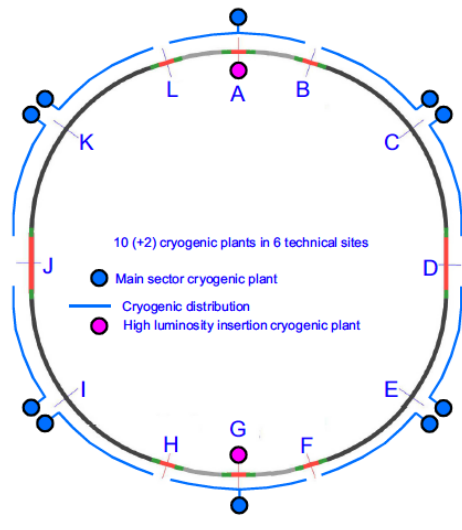
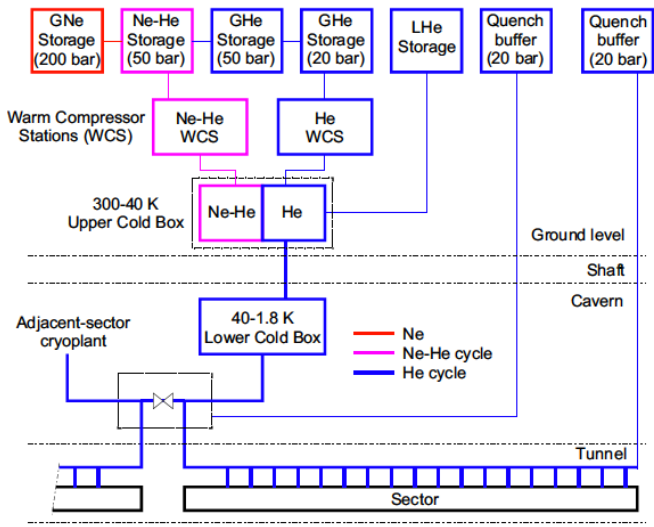

Component	Diameter (mm)
Line B	630
Line C	80
Line D	200
Line E	250
Line F	250
Vacuum jacket of pipe elements	1350
Flanges and bellows of pipe elements	1450
Vacuum jacket of service modules	1500

FCC-hh conceptual design

Temperature levels

- 40 – 60 K for the thermal shield as major heat intercept
- 40 – 60 K to cool the beam screens
- 1.9 K quasi isothermal to cool the magnet cold masses
- 4 K very low pressure (VLP) to transport helium to the 1.8 K units
- 4.5 K normal saturated helium for SRF cavities and lower sections of HTS current leads
- 40 – 300 K for the cooling of resistive upper sections of HTS current leads

Nominal main tunnel user heat loads

Temperature level	40–60 K (kW)	1.9 K (kW)	4 K VLP (kW)	4.5 K (kW)	40–290 K (g/s)
Cold mass steady state load, Q_{cm}		12			
Additional load for transient mode		3			
Beamscreen load, Q_{bs}	504				
Magnet thermal shield load, Q_{tsm}	44.5				
Distribution thermal shield load, Q_{tsd}	33.5				
Pumping line (line B) load, Q_b			2		
Current leads cooling, Q_{cl}					85
RF cavity modules (Point H left or right)				1.5	
Total	580	15	2	1.5	85

(per 10 km long sector)

Capacity of 1 sector cryogenic plant equivalent to ≈ 110 kW @ 4.5 K

FCC-hh conceptual design

Cooling scheme

- Half-cell = a string of one quadrupole and 6 cryo-dipoles / ≈ 107 m of length
- Repetitive scheme all along the sectors
- Sector cooling length of 8400 m
- 790 parallel cooling loops

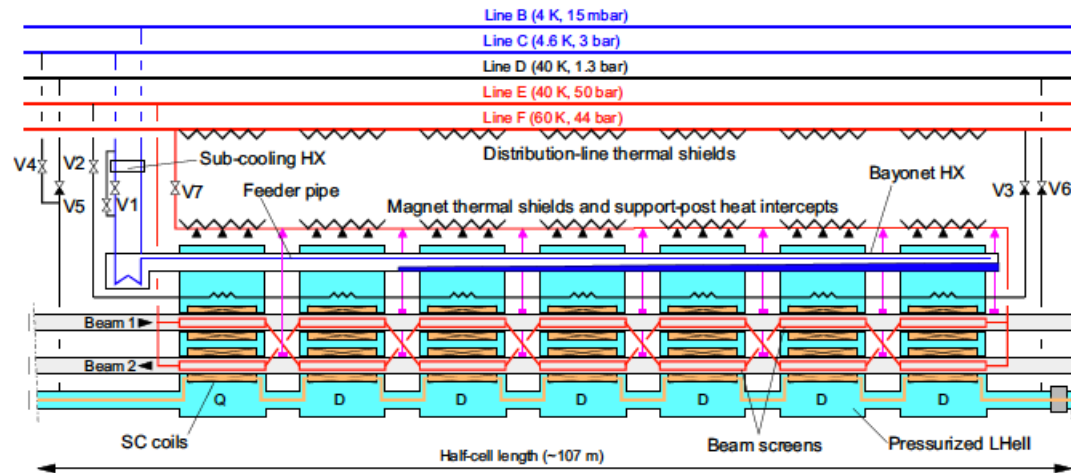

FCC-hh conceptual design

Helium inventory and electrical consumption

- **Total helium inventory of ≈ 880 t**, equally shared between cold mass & distribution
- **Neon inventory of 500 kg per cryoplant**
i.e. **5 t in total**
- **Required electrical power is 24 MW per main sector cryoplant** i.e. **240 MW in total**



- GHe storage - 60 (250 m³, 20 bar)
- Quench buffer - 156 (250 m³, 20 bar)
- GHe storage - 10 (250 m³, 50 bar)
- Ne-He storage - 10 (250 m³, 50 bar)
- GNe cylinders - 10 (10 m³, 200 bar)
- LHe storage - 50 (120 m³)
- LHe boil-off liquefier - 6 (150 to 300 l/h)
- LN2 storage - 6 (50 m³)

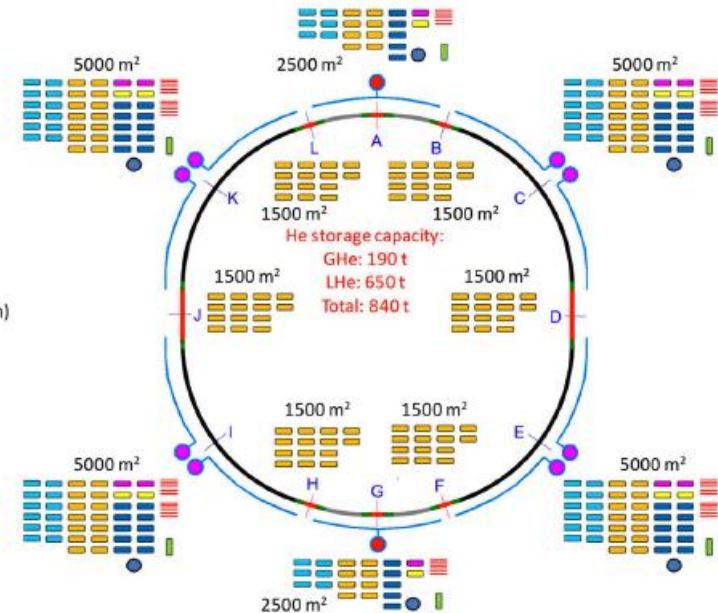

Organization of the cryogenics work

6 pillars



Study Coordination

Physics and experiments P. Janot NN	Accelerators ?? T. Raubenheimer (SLAC)?? F. Zimmermann (<mid 22) J. Wenninger (>mid22)	Techn. coordination techn. Infrastructure K. Hanke (from 7/21) V. Mertens (till 7/21)	Host State processes and civil engineering LD Opened	Organisation and financing models NN	Study support and coordination M. Benedikt
physics programme NN	ee & FEB design K. Oide (KEK) A. Chance (CEA)	electrical infrastructure JP. Burnet	administrative processes F. Eder (>9/21)	organisation model NN	study/collaboration secretariat J. Hadre
detector concepts NN	hh design M. Giovannozzi	cooling & ventilation G. Peon	placement studies V. Mertens (<12/21)	financing model F. Donnemann	study support unit NN
physics performance P. Azzi (INFN) E. Perez	technology R&D R. Losito	integration, transport, logistic C. Colloca	environmental evaluation NN	procurement strategy and rules NN	EU projects NN
software and computing G. Ganis C. Helsens (<10.21)	ee MDI M. Boscolo (INFN)	general safety, access radiation protection, T. Otto	tunnel, subsurface design J. Osborne	in-kind contributions NN	collaboration building E. Tsesselis
	ee injector P. Craievich (PSI)	Cryogenics, geodesy survey, computing infrastructure, operation and maintenance- reliability See WBS of K. Hanke	surface buildings design NN	operation model P. Collier	Communications P. Charitos J. Gillies (local comm)
			landplots and access NN		

Courtesy M. Benedikt

FCC Study Phase II Organization & Cryogenics Group involvement since March'21

- Technical Infrastructures:
 - L. Delprat
- Technology R&D:
 - Cavities:
 - K. Brodzinski, L. Delprat
 - Magnets:
 - R. Van Weelderen, P. Tavares
- Detectors concepts:
 - J. Bremer, C. Fabre

Objectives of the second study phase ('21-'25)

Main deliverables and overall timeline

	2021	2022	2023	2024	2025
Technical design work and R&D in all WPs					
Communication plan and implementation			X		
Placements studies, preferred implementation variant identification	X				
CDR design review and requirements update	X				
General design update for preferred implementation variant		X			
General coherence review across WPs			X		
Detailed design for Feasibility Study Report				X	
Environmental evaluation process and impact study with Host States					
High risks areas site investigations					X
Feasibility Study Report Completed					X

Courtesy M. Benedikt

Conclusion

- New cryogenic team progressing with integrating into the project & familiarization with CDR conclusions
- Next steps:
- Civil engineering: identification of the preferred implementation variant
- Participation with cryogenic contribution to FCC week on July 1st '21
- Technical Infrastructure Working Group
 - Work Package 6 “Cryogenic Systems” / Description to be edited
 - Cryogenic systems design update, based on preferred implementation variant
 - Main impact of the number of access points on the cryogenic layout

A large, thick, light blue sine wave graphic that spans across the center of the slide, partially overlapping the text.

Thank you
for your attention.



SPARES

FCC-ee collider parameters

Courtesy M. Benedikt, FCCIS kick-off meeting, November 9th 2020

parameter	Z	WW	H (ZH)	ttbar
beam energy [GeV]	45	80	120	182.5
beam current [mA]	1390	147	29	5.4
no. bunches/beam	16640	2000	393	48
bunch intensity [10^{11}]	1.7	1.5	1.5	2.3
SR energy loss / turn [GeV]	0.036	0.34	1.72	9.21
total RF voltage [GV]	0.1	0.44	2.0	10.9
long. damping time [turns]	1281	235	70	20
horizontal beta* [m]	0.15	0.2	0.3	1
vertical beta* [mm]	0.8	1	1	1.6
horiz. geometric emittance [nm]	0.27	0.28	0.63	1.46
vert. geom. emittance [pm]	1.0	1.7	1.3	2.9
bunch length with SR / BS [mm]	3.5 / 12.1	3.0 / 6.0	3.3 / 5.3	2.0 / 2.5
luminosity per IP [$10^{34} \text{ cm}^{-2}\text{s}^{-1}$]	230	28	8.5	1.55
beam lifetime rad Bhabha / BS [min]	68 / >200	49 / >1000	38 / 18	40 / 18

FCC-hh collider parameters

Courtesy M. Benedikt, FCCIS kick-off meeting, November 9th 2020

parameter	FCC-hh		HL-LHC	LHC
collision energy cms [TeV]	100		14	14
dipole field [T]	16		8.33	8.33
circumference [km]	97.75		26.7	26.7
beam current [A]	0.5		1.1	0.58
bunch intensity [10^{11}]	1	1	2.2	1.15
bunch spacing [ns]	25	25	25	25
synchr. rad. power / ring [kW]	2400		7.3	3.6
SR power / length [W/m/ap.]	28.4		0.33	0.17
long. emit. damping time [h]	0.54		12.9	12.9
beta* [m]	1.1	0.3	0.15 (min.)	0.55
normalized emittance [μm]	2.2		2.5	3.75
peak luminosity [$10^{34} \text{ cm}^{-2}\text{s}^{-1}$]	5	30	5 (lev.)	1
events/bunch crossing	170	1000	132	27
stored energy/beam [GJ]	8.4		0.7	0.36

FCC Roadmap

Feasibility study to be delivered end 2025 as input for ESPP Update expected for 2026/2027, to enable a project decision:

- *Feasibility study of the 100 km tunnel (infrastructure aspects, administrative aspects, local authorities, environment, energy, etc.)*
- *High-risk areas site investigations included, to confirm principle feasibility*
- *Host-state related processes, to allow start of construction early 2030ies.*
- *CDR+ for colliders and injectors, including key technology proofs.*
- *HFM program intermediate milestones, in line with long-term R&D plan.*
- *Physics and experiments CDR + for FCC integrated project.*
- *Financing concept & organization model for project and operation phases.*
- For all these activities the sequential nature of implementation of the colliders and the overall timeline needs to be taken into account!

FCC Timeline

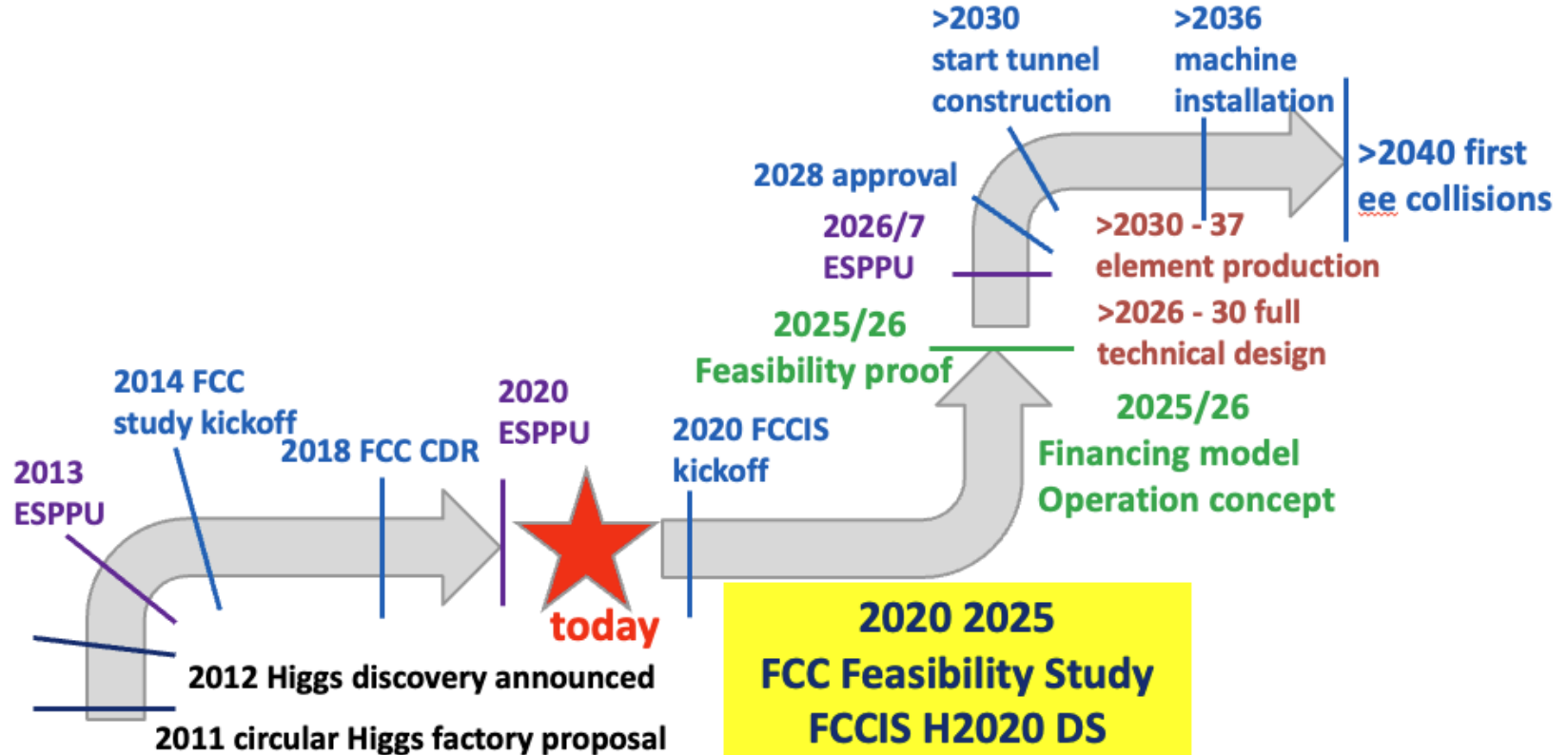

2040

2065

FCC Integrated Project Technical Schedule

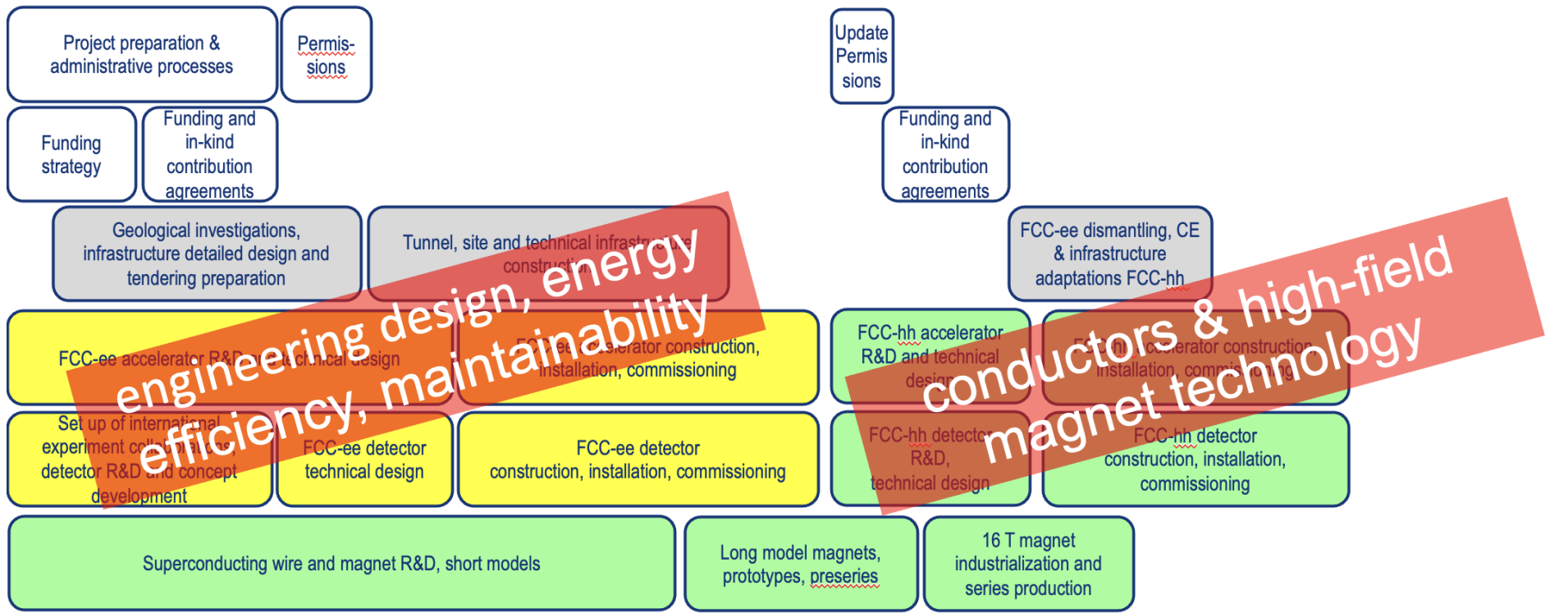

engineering design, energy efficiency, maintainability

conductors & high-field magnet technology

FCC Civil Engineering Preparatory Activities

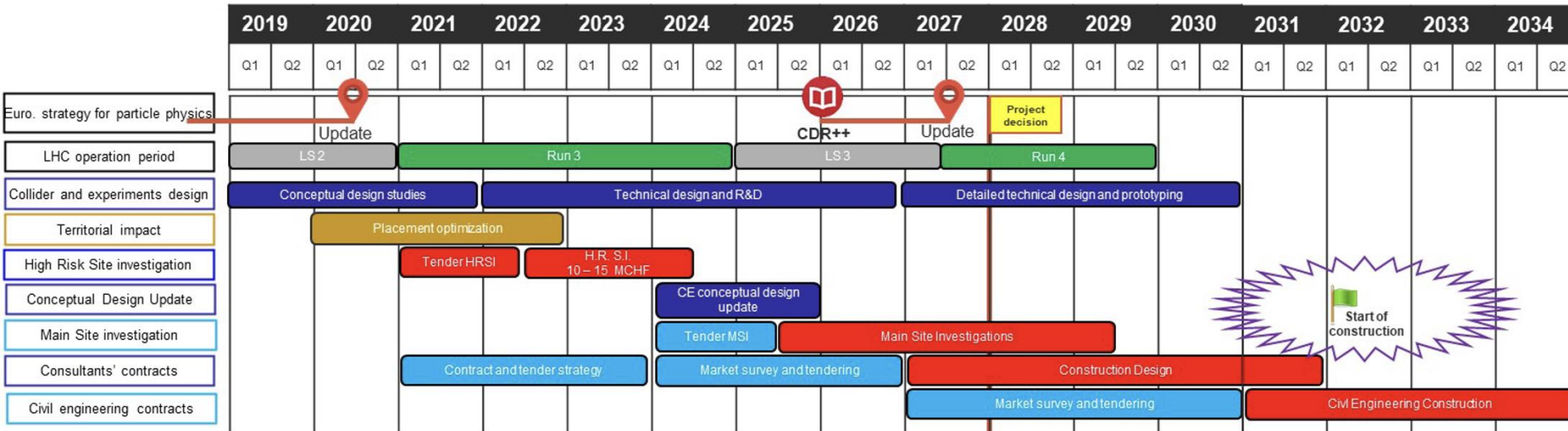

- **Technical schedule of main processes leading to start of construction begin 2030ies**
- **For proof of principle feasibility: High risk area site investigations, 2022 – 2024**
- **Followed by update of civil engineering conceptual design and CE cost estimate 2025**

FCC-ee physics operation model

working point	assumed typical luminosity/IP [$10^{34} \text{ cm}^{-2}\text{s}^{-1}$] = design value minus 15(10)%	total luminosity (2 IPs)/ yr; half of typical luminosity assumed in 1st two years (Z) and 1st year ($t\bar{t}$)	physics goal	run time [yr]
Z first 2 years	100	26 $\text{ab}^{-1}/\text{year}$	150 ab^{-1}	4
Z later	200	48 $\text{ab}^{-1}/\text{year}$		
W	25	6 $\text{ab}^{-1}/\text{year}$	10 ab^{-1}	1-2
H	7.0	1.7 $\text{ab}^{-1}/\text{year}$	5 ab^{-1}	3
machine modification for RF installation & rearrangement: 1 year				
top 1st year (350 GeV)	0.8	0.2 $\text{ab}^{-1}/\text{year}$	0.2 ab^{-1}	1
top later (365 GeV)	1.4	0.34 $\text{ab}^{-1}/\text{year}$	1.5 ab^{-1}	4
total program duration: 15 years – incl. machine modifications				
phase 1 (Z, W, H): 9 years, phase 2 (top): 6 years				

FCC-hh conceptual design, heat loads

Distributed steady-state heat loads, nominal conditions

Temperature level		40–60 K	1.9 K	4 K VLP
Static heat in-leaks (W/m)	Cold mass supporting system	2.4	0.13	
	Radiative insulation		0.13	
	Thermal shield	3.1		
	Feedthrough and vacuum barrier	0.2	0.1	
	Beamscreen Distribution	3.6	0.1	0.24
Total static		9.3	0.58	0.24
Dynamic heat loads (W/m)	Synchrotron radiation	57	0.08	
	Image current	3.4		
	Resistive heating in splices		0.3	
	Beam-gas scattering		0.45	
Total dynamic		60	0.83	
Total		70	1.4	0.24
Dynamic range		8	2.5	1

Main superfluid helium cooling loop parameters

Parameter	Unit	LHC	FCC-hh
Unit cooling length	m	106.9	107.1
Sector cooling length	m	2900	8400
Number of parallel cooling loops (total)	–	216	790
Average nominal heat load	W/m	0.40	1.4
Bayonet heat exchanger inner diameter	mm	53.4	83.1
Feeder pipe inner diameter	mm	10.0	15.0
Wall thickness of bayonet heat exchanger	mm	2.3	5.0
Joule-Thomson valve inlet temperature	K	2.18	2.18
Free longitudinal cross-section area	cm ²	60	156
ΔT max pressurised saturated HeII	mK	50	50
Cold mass operating pressure	bar	1.3	1.3
Pumping line (B) diameter	mm	270	630
Helium supply line (C) diameter	mm	100	80
Heat load on pumping line	W/m	0.11	0.24
Pumping pressure at cryogenic plant interface	mbar	15	15
Maximum cold mass helium temperature	K	1.9	1.9

Main beam screen cooling loop parameters

Parameter	Unit	LHC	FCC-hh
Unit cooling length	m	53.4	107.1
Sector cooling length	m	2900	8400
Number of parallel cooling loops (total)	–	432	790
Average beamscreen nominal heat load	W/m	1.6	60
Supply pressure	bar	3	50
Supply helium temperature	K	5	40
Max. allowed BS temperature	K	20	60
BS helium outlet temperature (nominal)	K	20	57
Minimum BS temperature (nominal)	K	5	43
BS pressure drop (nominal)	bar	0.5	4.3
ΔP control valve (nominal)	bar	0.8	1
ΔP supply and return line (nominal)	bar	0.4	0.5
Total cooling loop pressure drop	bar	1.7	5.8
Supply/return header (E/F) diameter	mm	100/150	250/250
Exergetic efficiency (distribution only)	%	76	86
Total exergetic efficiency (with cold circulator)	%	N/A	82
Total exergetic efficiency (with warm circulator)	%	N/A	71