

# Baseline & Cavity options for FCC-ee

Franck Peauger on behalf of the FCC SRF team  
SY/RF/SRF

29-June-2021



FCC Week 2021

28 June 2021 to 2 July 2021  
Europe/Zurich timezone

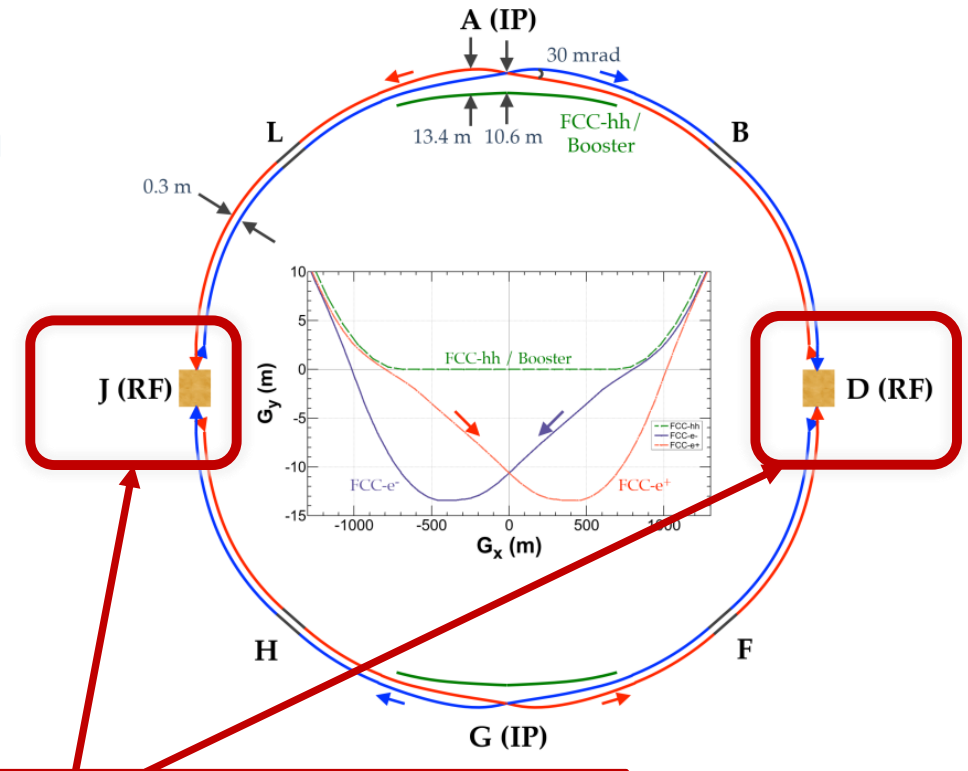

- Point J and point D are straight sections dedicated to SRF cavities (cryomodules) and klystrons
- Total length of straight section without kickers: 2.2 km

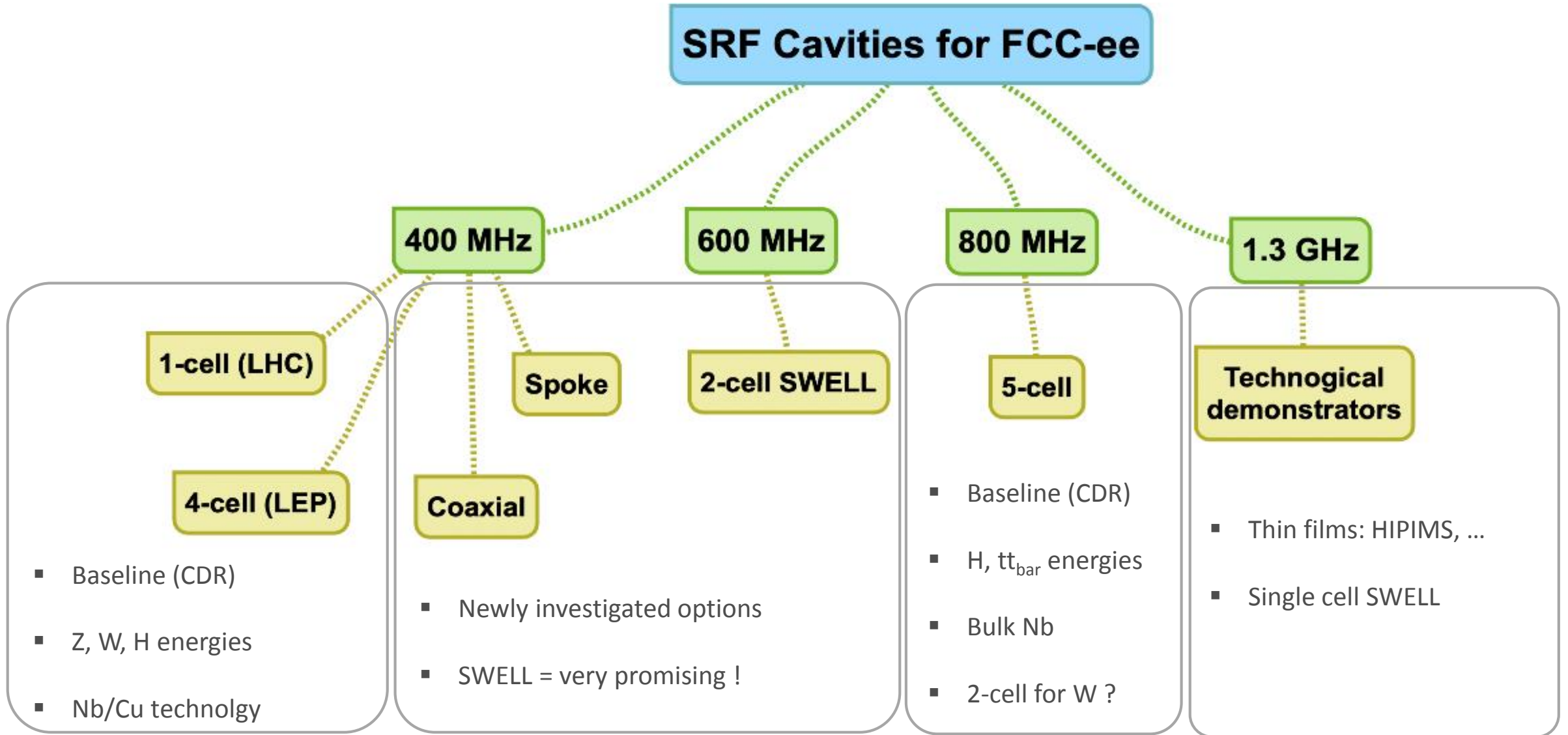

# FCCee RF system baseline

- Designed for fixed synchrotron radiation power of 50 MW per beam
- Elliptical shape

O. Brunner et al.

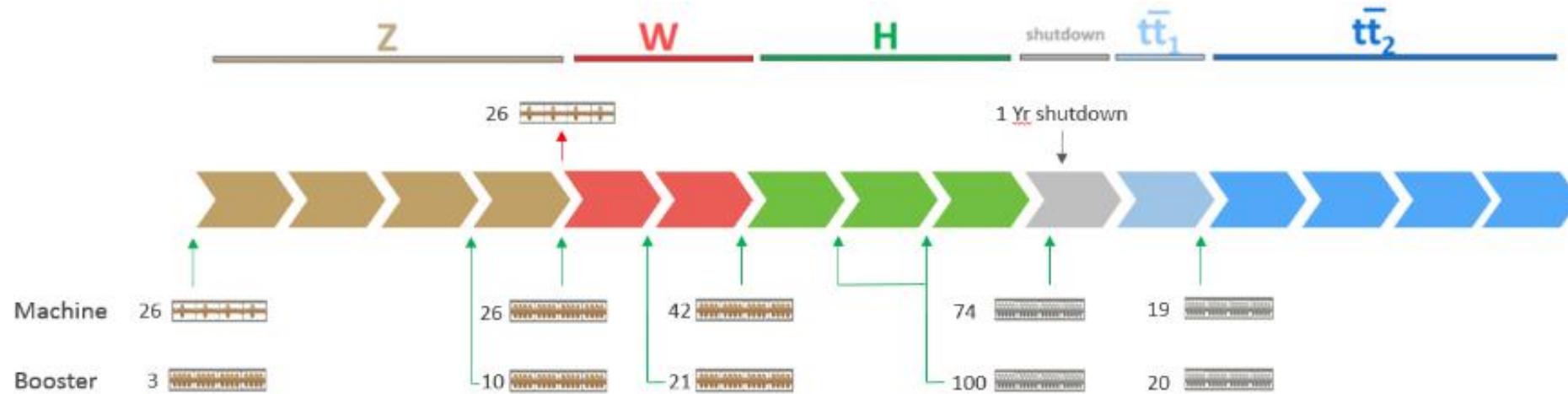

- 400 MHz 1-cell cavities
- Nb/Cu, 4.5 K
- 104 cavities
- Eacc=5 MV/m
- 1 MW /cav
- 4 cav./cryom.
- Re-used for FCC-hh



- 400 MHz 4-cell cavities
- Nb/Cu, 4.5 K
- 408 cavities
- Eacc=10 MV/m
- 1 MW to 200 kW per cav.
- 4 cav./cryom.

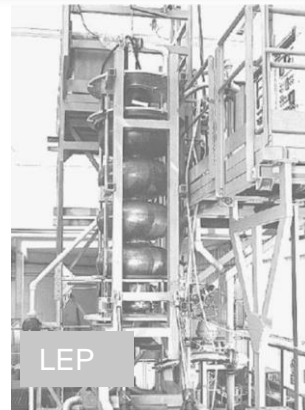

- 800 MHz 5-cell cavities
- bulk Nb, 2 K
- 852 cavities
- Eacc=20 MV/m
- 200 kW/cav.
- 4 cav./cryom.



# FCCee RF system baseline

CDR FCC-ee: The Lepton Collider, 2019

Table 3.12: Detailed RF configuration of each machine and booster ring.

	Z		WW		ZH		tt <sub>1</sub>		tt <sub>2</sub>	
	per beam	booster	per beam	booster	per beam	booster	2 beams	booster	2 beams	booster
Total RF voltage [MV]	100	140	750	750	2000	2000	9500	9500	10930	10930
<b>Frequency [MHz]</b>	<b>400</b>									
RF voltage [MV]	100	140	750	750	2000	2000	4000	2000	4000	2000
E <sub>acc</sub> [MV/m]	5.1	8	9.6	9.6	9.8	9.8	10	10	10	10
# cell / cav	1	4	4		4		4		4	
V <sub>cavity</sub> [MV]	1.92	12	14.4	14.4	14.7	14.7	15		15	
# cavities	52	12	52	52	136	136	272	136	272	136
# CM	13	3	13	13	34	34	68	34	68	34
T operation [K]	4.5		4.5		4.5		4.5		4.5	
Dyn losses/cav [W]	14	11	210	26	202	29	210	30	210	30
Stat losses/cav [W]	8		8		8		8		8	
Q <sub>ext</sub>	4.4 10 <sup>4</sup>		6.6 10 <sup>5</sup>		1.9 10 <sup>6</sup>		4 10 <sup>6</sup>		4.7 10 <sup>6</sup>	
P <sub>cav</sub> [kW]	962		962		368		175		149	
<b>Frequency [MHz]</b>	<b>800</b>									
RF voltage [MV]							5500	7500	6930	8930
E <sub>acc</sub> [MV/m]							19.8	20	19.8	19.8
# cell / cav							5		5	
V <sub>cavity</sub> [MV]							18.6	18.75	18.6	18.6
# cavities							296	400	372	480
# CM							74	100	93	120
T operation [K]							2		2	
Dyn losses/cav [W]							66	10	66	10
Stat losses/cav [W]							8		8	
Q <sub>ext</sub>							3.9 10 <sup>6</sup>		5.6 10 <sup>6</sup>	
P <sub>cav</sub> [kW]							176		155	

Required RF power per cavity as a function of loaded quality factor QL with optimal detuning for beam loading compensation

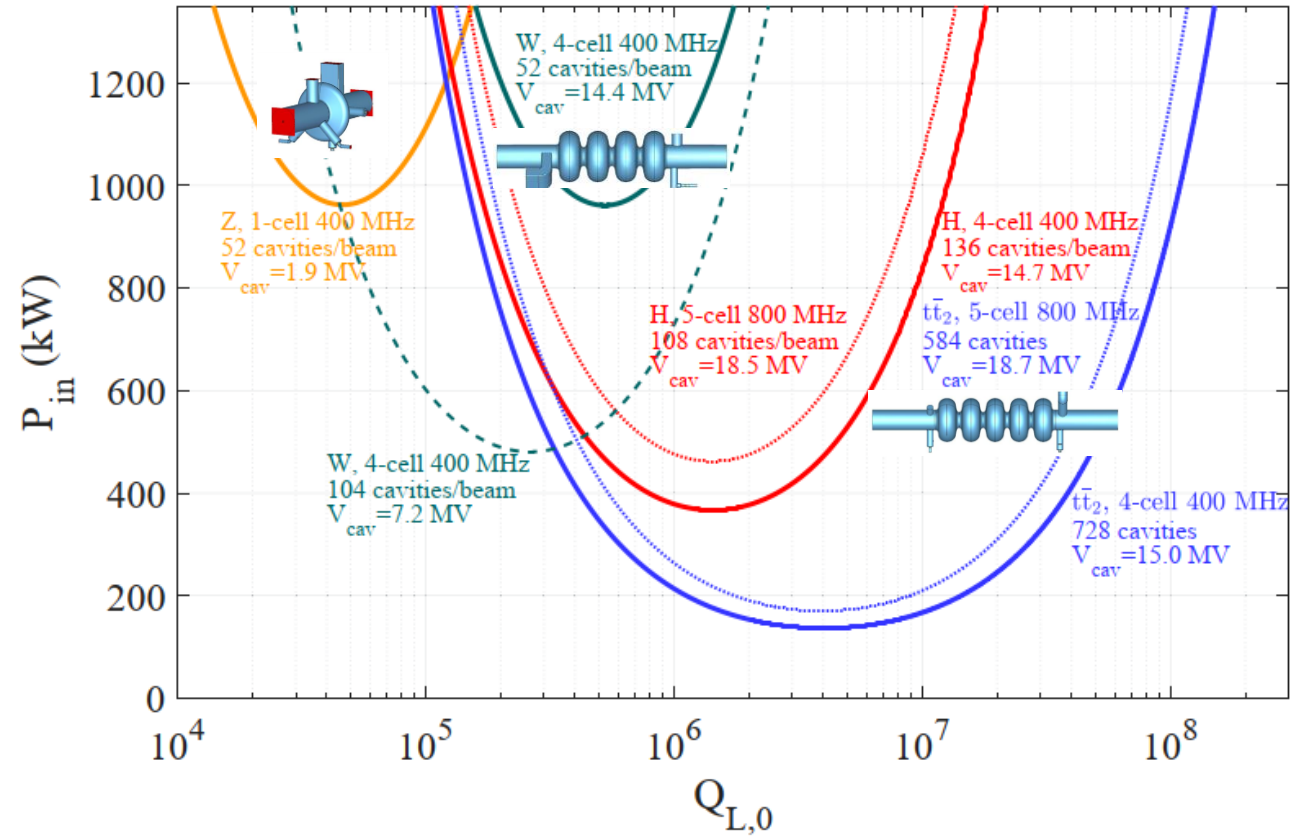

Thesis of **Shahnam Gorgi Zadeh**  
(Univ. of Rostock), supervised by Rama Calaga, 2020

# “LHC type cavity” design for the Z machine

- Single cell elliptical cavity (with a longitudinal trapped mode)

High order mode power loss evaluation in future circular electron-positron collider cavities, Ivan Karpov et al., PRAB 21, 2018

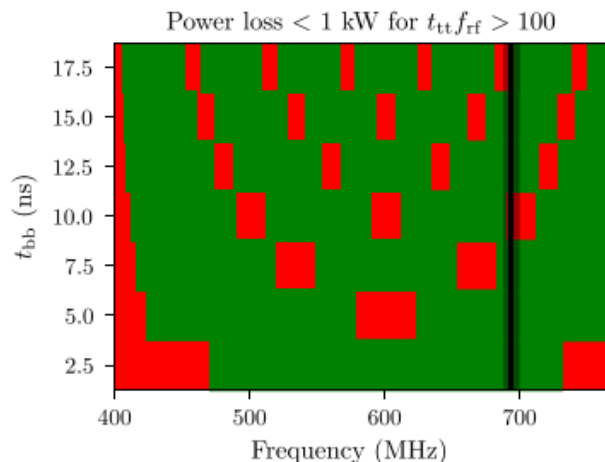
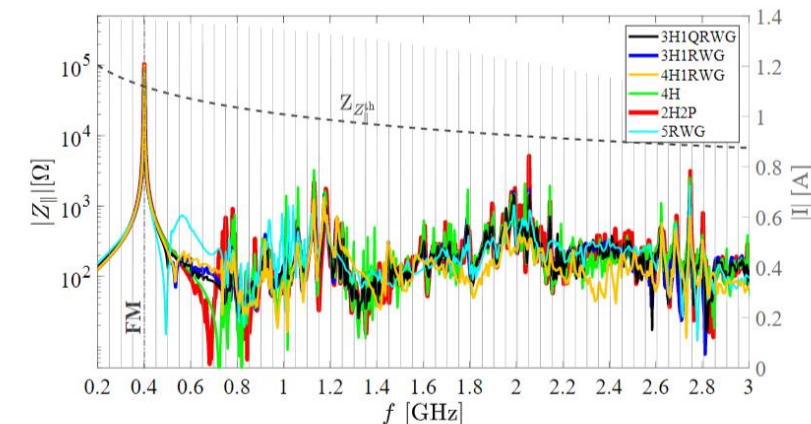
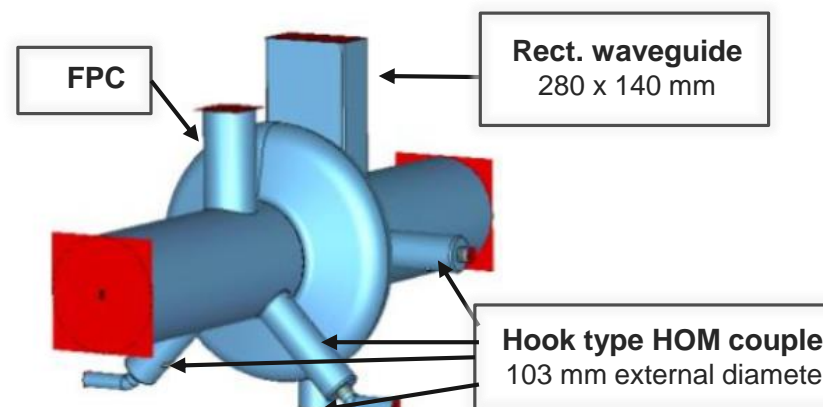

FIG. 21. Frequency ranges with acceptable power loss below 1 kW for different bunch spacings (green regions). Regions with power loss above 1 kW are shown with red color. The vertical black line corresponds to the position of HOM in the single-cell cavity with the maximum frequency shift of  $\pm 5$  MHz. The considered frequency range is limited by the frequency of the fundamental mode (400.79 MHz) and the cutoff frequency (765 MHz).

- Single cell elliptical cavity (no longitudinal trapped mode) with 1 FPC and 4 hooks type + 1 WG HOM couplers

- ✓  $F = 400.79$  MHz
- ✓  $E_{acc} = 5.1$  MV/m,  $V_{cav} = 1.9$  MV
- ✓  $P_{input} = 1$  MW (in CW)



(c) Longitudinal impedance of the four-cavity module with tapering

Thesis of **Shahnam Gorgi Zadeh** (Univ. of Rostock), supervised by Rama Calaga, 2020

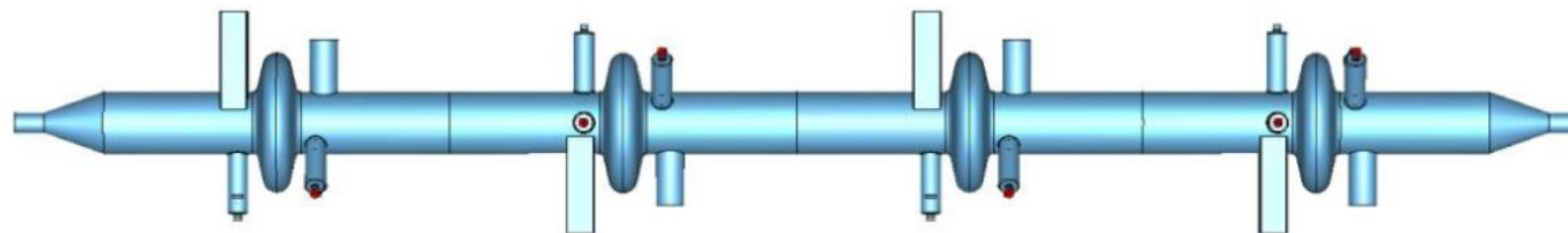

# “LEP type cavity” design for the W,H machine

## 4-cell elliptical cavity with 1 FPC and a combination of two DQW coaxial couplers and one waveguide coupler

Thesis of **Shahnam Gorgi Zadeh**  
(Univ. of Rostock), supervised by Rama Calaga, 2020

**Table 4.3:** RF parameters of the proposed four-cell (FCC<sub>UROS4</sub>) and five-cell (FCC<sub>UROS5</sub>) cavities. The cavities are compared with two five-cell cavities designed for operation in PERLE [78, p. 61].

Parameters	FCC <sub>UROS4</sub> *	FCC <sub>UROS5</sub> *	CERN <sub>2</sub>	JLab <sub>2</sub>
Frequency, $f_0$ [MHz]	400.79	801.58	801.58	801.58
Number of cells, $N_{\text{cell}}$	4	5	5	5
$R/Q_{\parallel,0}$ [ $\Omega$ ]	411.3	520.6	393	523.9
$G$ [ $\Omega$ ]	273.2	272.9	283	274.6
$G \cdot R/Q_{\parallel,0}$ [ $\Omega^2$ ]	112367	142072	111219	143862
$B_{\text{pk}}/E_{\text{acc}}$ (middle cell) [ $\frac{\text{mT}}{\text{MV/m}}$ ]	4.2	4.2	4.92	4.2
$E_{\text{pk}}/E_{\text{acc}}$ (middle cell)	2.0	2.0	2.4	2.26
Cavity active length, $L_{\text{active}}$ [mm]	1465.1	919.5	935	917.9
Radius of the middle cells, $R_i$ [mm]	120	60	80	65
Beam pipe radius, $R_{\text{bp}}$ [mm]	156	78	80	65
Wall angle of middle cell, $\alpha$ [ $^\circ$ ]	100	100	102.5	90
$k_{\text{cc}}$ of the middle cell [%]	2.25	2.25	5.75	3.21
$k_{\text{cc}}$ of the cavity [%]	1.92	2.04	5.19	2.93
Field flatness, $\eta_{\text{ff}}$ [%]	99	99	96	99
$k_{\parallel}$ ( $\sigma_z = 2$ mm) [V/pC]	2.27	3.37	2.63	2.74
$f_{\text{cut}}$ TE <sub>11</sub> for $R_{\text{bp}}$ [GHz]	0.563	1.126	1.10	1.35
$f_{\text{cut}}$ TM <sub>01</sub> for $R_{\text{bp}}$ [GHz]	0.7355	1.471	1.43	1.77
$N_{\text{cell}}^2/k_{\text{cc}}$	833	1225	481	853

\* The designed cells are adapted to a four-cell cavity at 400.79 MHz and a five-cell cavity at 801.58 MHz.

Middle cell

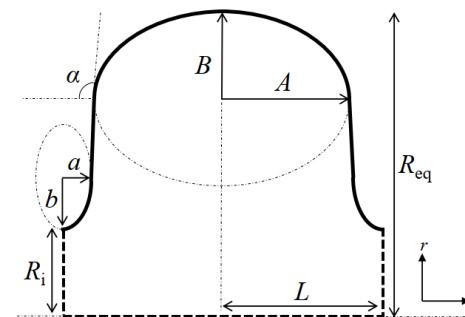

**Table 4.1:** A list of optimized middle cells with a different aperture radius,  $E_{\text{pk}}/E_{\text{acc}}$  and  $\alpha$ . The cavities are tuned to 400.79 MHz and the length of the half-cell is 187 mm for all cases.

A [mm]	B [mm]	a [mm]	b [mm]	$R_i$ [mm]	$R_{\text{eq}}$ [mm]	$\alpha$ [ $^\circ$ ]	$\frac{E_{\text{pk}}}{E_{\text{acc}}}$	$\frac{B_{\text{pk}}}{E_{\text{acc}}}$ [ $\frac{\text{mT}}{\text{MV/m}}$ ]	$R/Q_{\parallel,0}$ [ $\Omega$ ]	$G$ [ $\Omega$ ]	$k_{\text{cc}}$ [%]
141.60	113.74	31.51	48.76	100	326.754	100	2.0	3.84	127	275.6	1.36
138.89	114.07	37.16	50.53	110	320.64	100	2.0	4.01	118.2	274.2	1.78
135.44	114.90	43.50	71.19	120	333.182	100	2.0	4.20	109.5	272.3	2.25

End cell

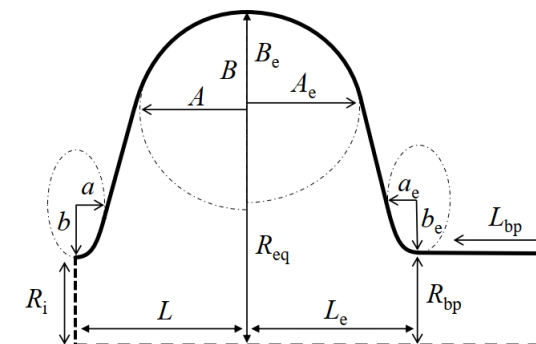

**Table 4.2:** End cell parameters.

$A_e$ [mm]	$B_e$ [mm]	$a_e$ [mm]	$b_e$ [mm]	$R_{\text{bp}}$ [mm]	$R_{\text{eq}}$ [mm]	$L_e$ [mm]	$\alpha_e$ [ $^\circ$ ]
133	102	34	46	156	333.182	171.532	96.9

# 800 MHz 5-cell cavity design for the ttb machine FUTURE CIRCULAR COLLIDER

- Scaled from the UROS4 geometry
- 1 FPC and a combination of two DQW coaxial couplers and one waveguide coupler

Thesis of **Shahnam Gorgi Zadeh**  
(Univ. of Rostock), supervised by Rama Calaga, 2020

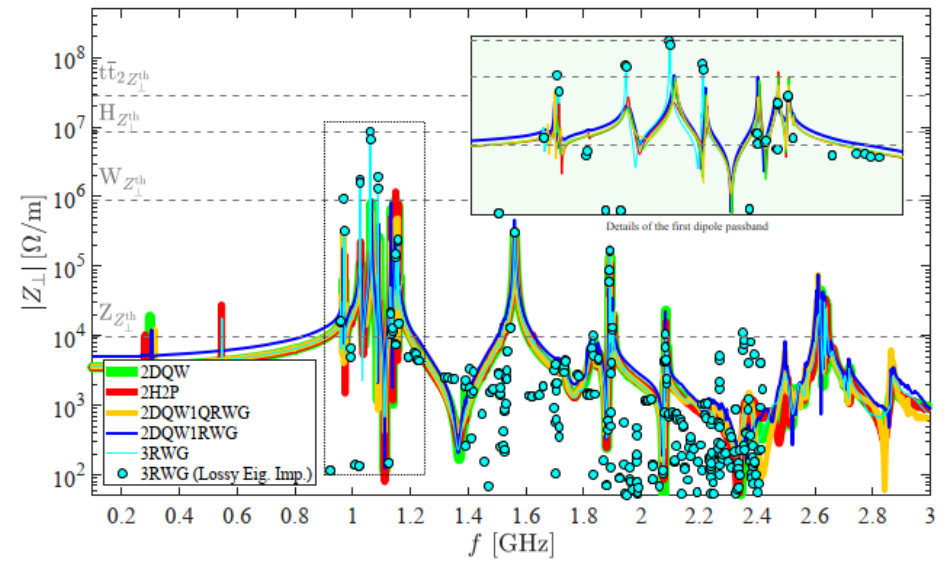

(b) Transversal impedance

**Figure 6.19:** Longitudinal impedance (a) and transversal impedance (b) of the single five-cell-cavity module. The wake impedances (solid lines) are calculated and extrapolated from the wake potentials with a wavelenght of 1000m. The markers correspond to the lossy eigenmodes calculated with the SSC method. The impedance thresholds are normalized to the number of cavities required for each energy option. The mode with high longitudinal impedance at 2.24 GHz is an octopole mode with  $Q_{ext} = 1.4 \times 10^8$  and  $R/Q_{||} = 3.6 \times 10^{-4}$ .

2DQW1RWG

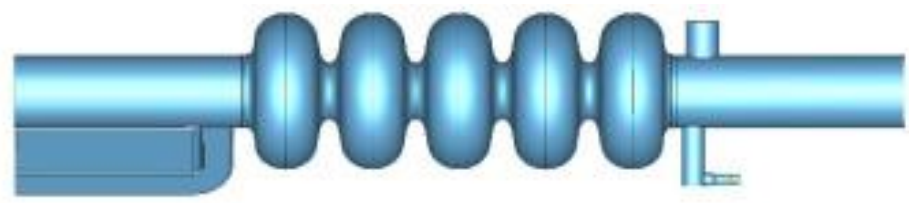

# Tentative design of alternative cavity shapes

Can we find a generic cavity able to cover all the FCCee machines ?

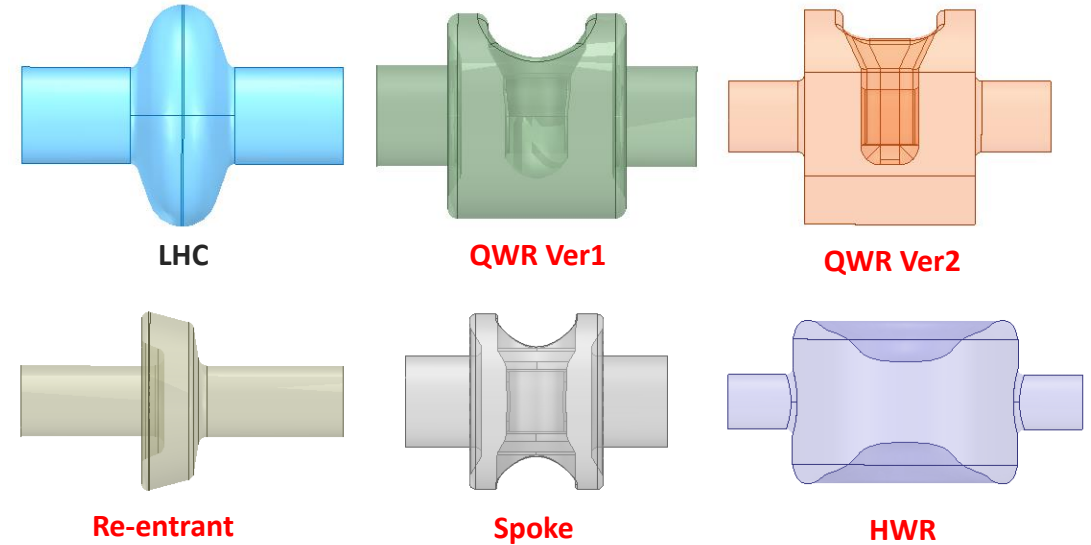

Parameters	LHC	HWR	Re-entrant	QWR Ver1	QWR Ver2	Spoke
Frequency [MHz]	400.79					
Operating temperature [K]	4.5					
Nominal Accelerating Voltage $V_{acc} = (E_{acc} \times L_{acc})$ [MV]	4					
Accelerating gradient $E_{acc}$ [MV/m]	10.6					
Circuit $r/Q$ [ $\Omega$ ] at $\beta=1$	42.7	41.9	44.33	46.69	44.8	63.25
$E_{pk}/E_{acc}$ at $\beta=1$	2.4	2.15	6.05	3.92	3.97	3.85
$B_{pk}/E_{acc}$ [mT/(MV/m)] at $\beta=1$	5.08	5.25	11.05	7.22	7.31	10
Max. surface electric field $E_{pk}$ [MV/m]	25.7	23	64.7	42	42.77	41.14
Max. surface magnetic field $B_{pk}$ [mT]	54.3	56.3	118.2	77.4	78.88	106.75
Stored energy [J] at nominal $E_{acc}$ and $\beta=1$	74	76	71.48	67.8	70.3	50.32
Aperture [mm]	300	170	220	313.5	220	283.7
Cavity envelope [mm]	688	790	556	637	665	543.8

- QWRs are excluded due to the difficulty to achieve at the same time the resonance at 400 MHz, the synchronization with  $\beta=1$  particle velocity and a large beam aperture
- Spoke cavities look promising but are very difficult to coat with Nb thin films
- A novel design of HWR with two poles is proposed and seems to be appropriate to the Nb sputtering technics. Also, very low surface fields is achieved with the help of spline type contours. However, the large cavity dimensions and the large number of HOM disqualify this geometry for FCCee
- The re-entrant cavity design looks also encouraging as it is very compact and has a clean HOM spectrum. Nevertheless, the operation at high accelerating gradient is limited due to high peak fields on the cavity surface

# Re-entrant cavity

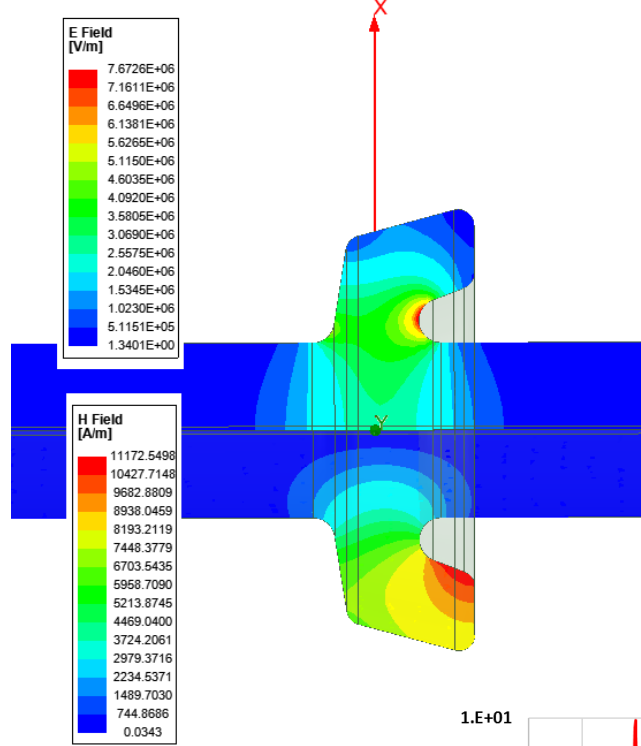

Inspired "200 MHz SC-RF system for the HL-LHC",  
 R. Calaga, R. Tomas  
 IPAC2016

Proceedings of IPAC2016, Buenos Aires, 2016

**A 200 MHz SC-RF SYSTEM FOR THE HL-LHC\***

R. Calaga, R. Tomas, CERN, Geneva, Switzerland

*Abstract*  
 A superconducting re-entrant cavity at 200 MHz is proposed for the HL-LHC as a component of the proposed 400 MHz RF system. The advantage of such a cavity would be to avoid the higher intensity and longer bunches with improved stability. Advantages related to minimizing electron cloud effects, transverse scattering, focusing and the possibility of beamstray heating with bunch length are described. Some considerations related to longitudinal beam stability, cavity optimization, beam loading and technological challenges are addressed.

**INTRODUCTION**  
 A sub-harmonic RF system at 200 MHz is proposed to replace the existing 400 MHz accelerating RF system in the LHC. The main goal is a lower frequency RF system.

*However, a new concept being a 1/3 resonator at frequencies of 200 MHz or below becomes attractive. A similar system was considered at 56.5 MHz for the MHC accelerator [2]. Figure 1 shows two such geometries at 200 MHz: (1) a part of the cavity optimization from the actual A/I resonator presented in Ref. [2] is related to version 1.*

Figure 1: Design evolution of a 200 MHz A/I resonator from the original proposal in Ref. [2].

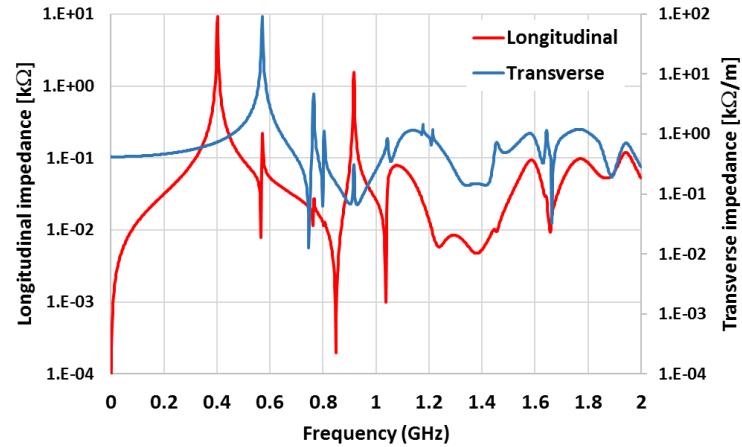

# Half Wave Resonator

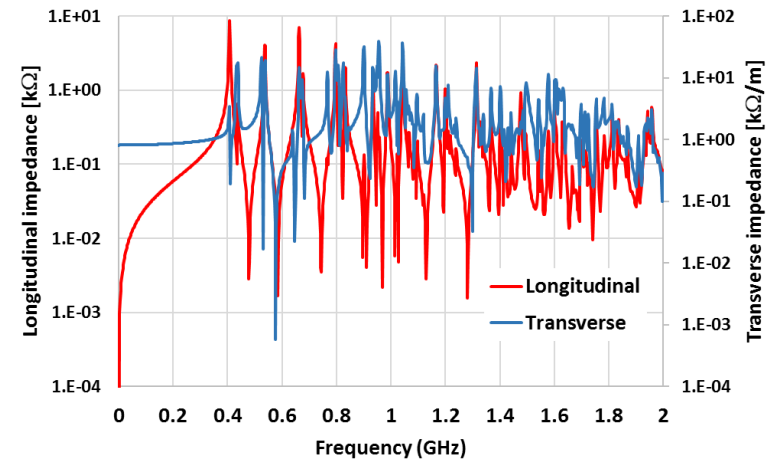
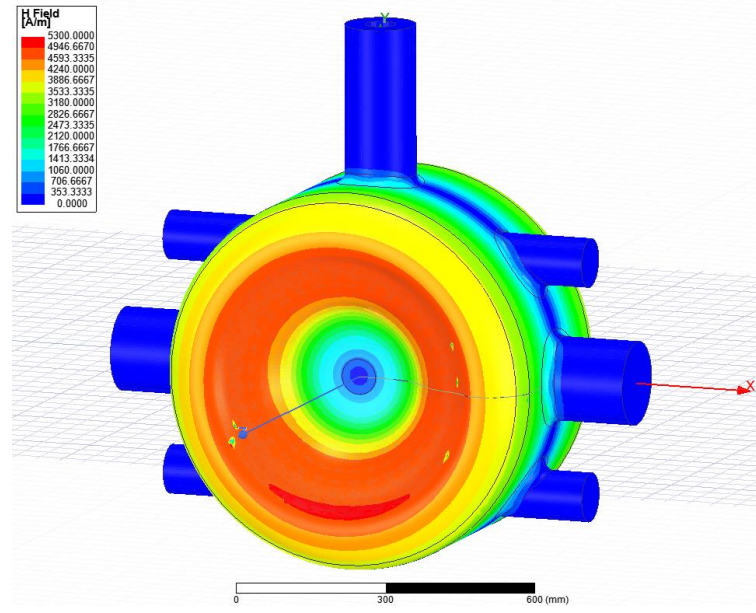

## 2 months of intense pre-study

- The approach of elliptical cavity equipped with radial slots crossing perpendicularly the cavity surface was evaluated
- This concept was already explored by Liu and Nassiri in 2010:

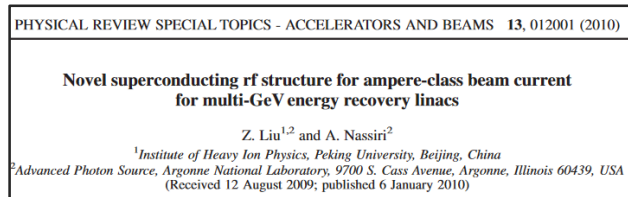

- Among the different cavity options described before, this **cavity alternative for FCCee type** was by far the most promising
- Fast and systematic RF simulations mixing eigenmode and wakefields calculations were performed
- The cavity performances were evaluated for different **number of cells** (from 1 to 4), different **number of slots** (from 4 to 8) and different operating **frequencies** (400, 600, 800 MHz)
- In particular, we checked that the longitudinal and transverse beam impedance of dangerous higher order modes are near the **threshold limits of multibunch instabilities**

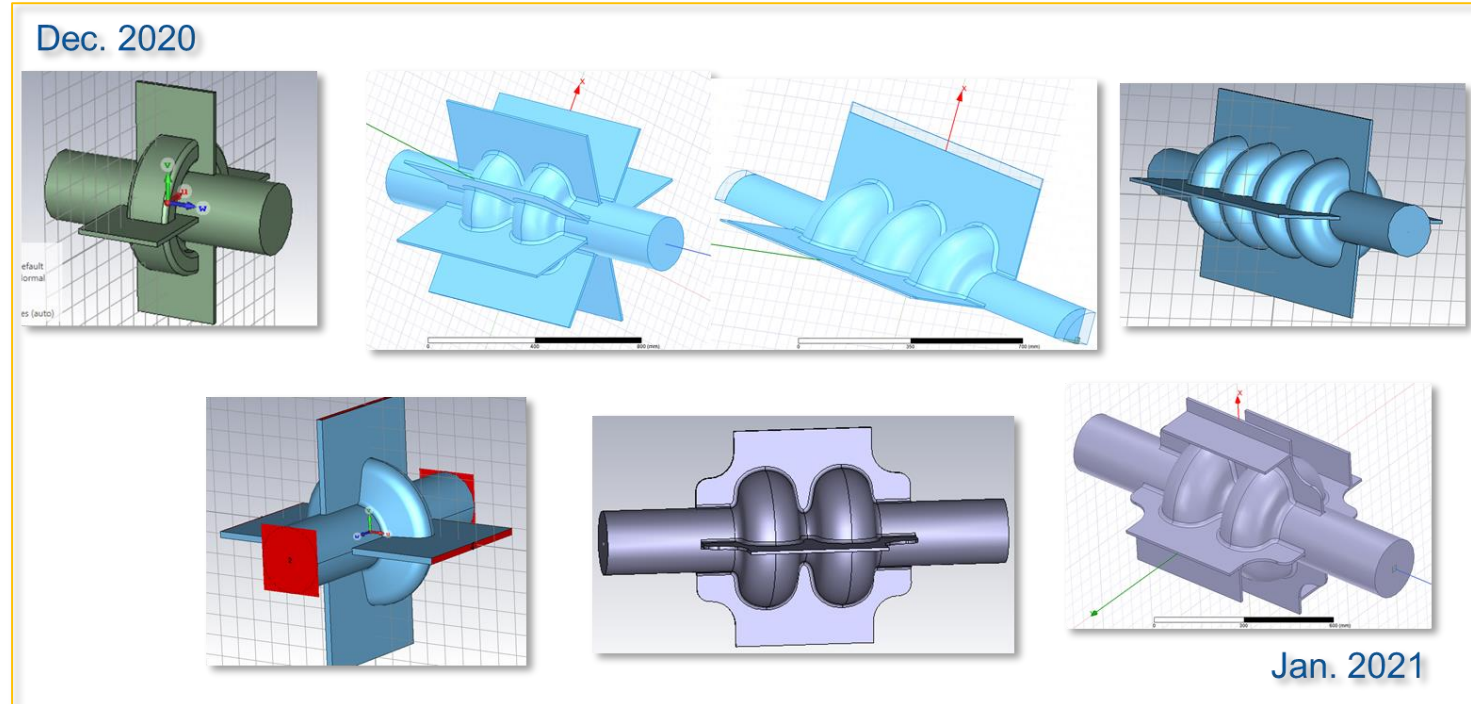

The SWELL superconducting cavity (at CERN) was born

# SWELL

- 2-cell, scaled from the UROS4 geometry
- 1 FPC
- 4 slots, 8 coaxial HOM extractors (for transverse modes)
- 2 HOM WGs (for longitudinal modes)

	Z	W	H	ttbar2
Frequency [MHz]			600	
r/Q [ $\Omega$ ] (circuit definition)			96.7	
Transit Time Factor			0.579	
G [ $\Omega$ ]			272.2	
Lacc [m]			0.5	
Epk/Eacc			2.86	
Bpk/Eacc [mT/(MV/m)]			5.72	
Accelerating voltage [MV]	1.2	3	8	10
Accelerating gradient Eacc [MV/m]	2.4	6	16	20
Max. surface electric field Epk [MV/m]	6.9	17.2	45.8	57.2
Max. surface magnetic field Bpk [mT]	13.7	34.3	91.5	114.4
Stored energy [J]	2	12.3	87.8	137.2

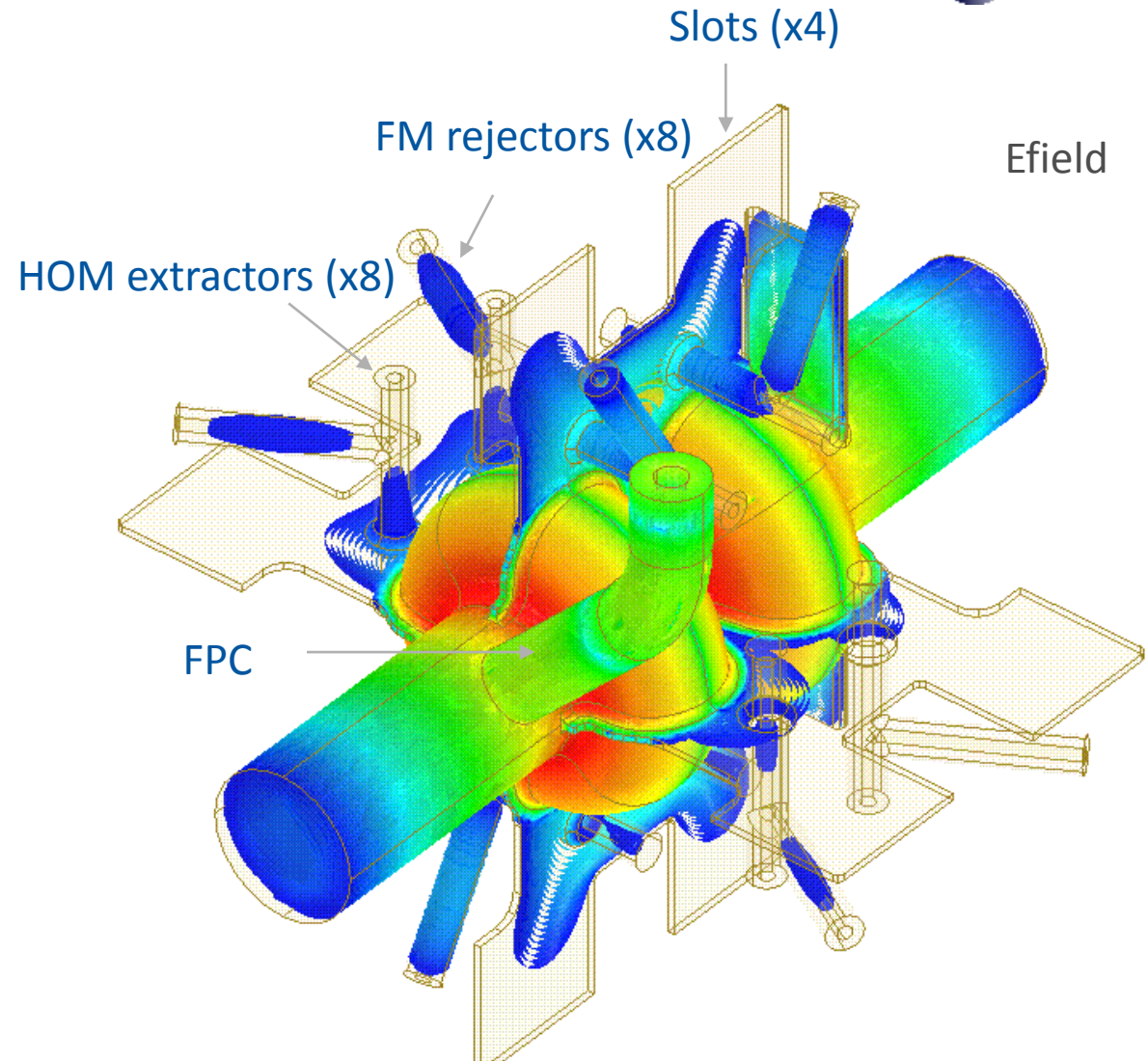

See talk "The SWELL cavity development", Igor Syratcev

A Superconducting Slotted Waveguide Elliptical Cavity for FCC-ee,  
**Y. Syratcev, F. Peauger, Y. Karpov, O. Brunner**, June 25, 2021  
<https://zenodo.org/record/5031953#.YNngQBHitPY>

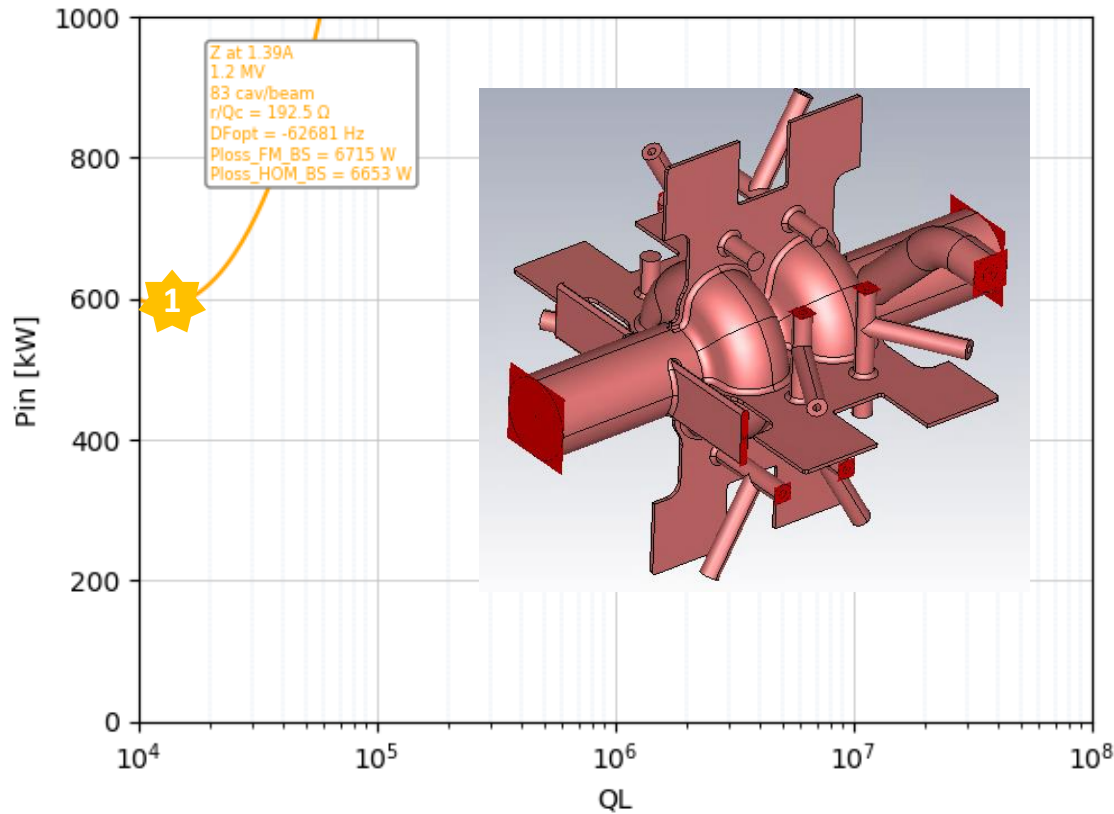

**1** Install 84 cavities per beam for the Z energy at nominal current of 1.39 A

- The RF power has an optimum loaded quality factor of  $QL=1.5 \times 10^4$ , and each cavity requires a minimum CW RF power of 600 kW
- The cavity operating voltage is  $V_{acc} = 1.2 \text{ MV}$ , corresponding to a gradient of  $E_{acc} = 2.4 \text{ MV/m}$
- The optimal detuning value is  $\Delta F = 62.6 \text{ kHz}$

$$\Delta f^* = \frac{-(R/Q_{||,0}) f_0 I_0 \sin \phi_s}{2V_{cav}}$$

- The HOM power per cavity is about 6.6 kW of at nominal beam current

$$P_{HOM} = k_{||,HOM} Q_b I_0$$

- Both, the HOM power and the detuning are challenging, but considered as achievable

84 klystrons / 84 cavities / 42 cryomodules per beam

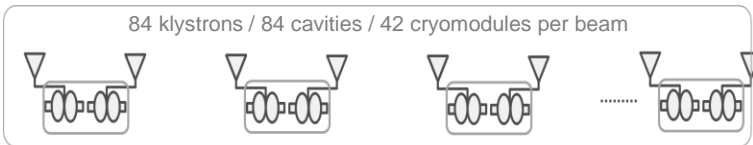

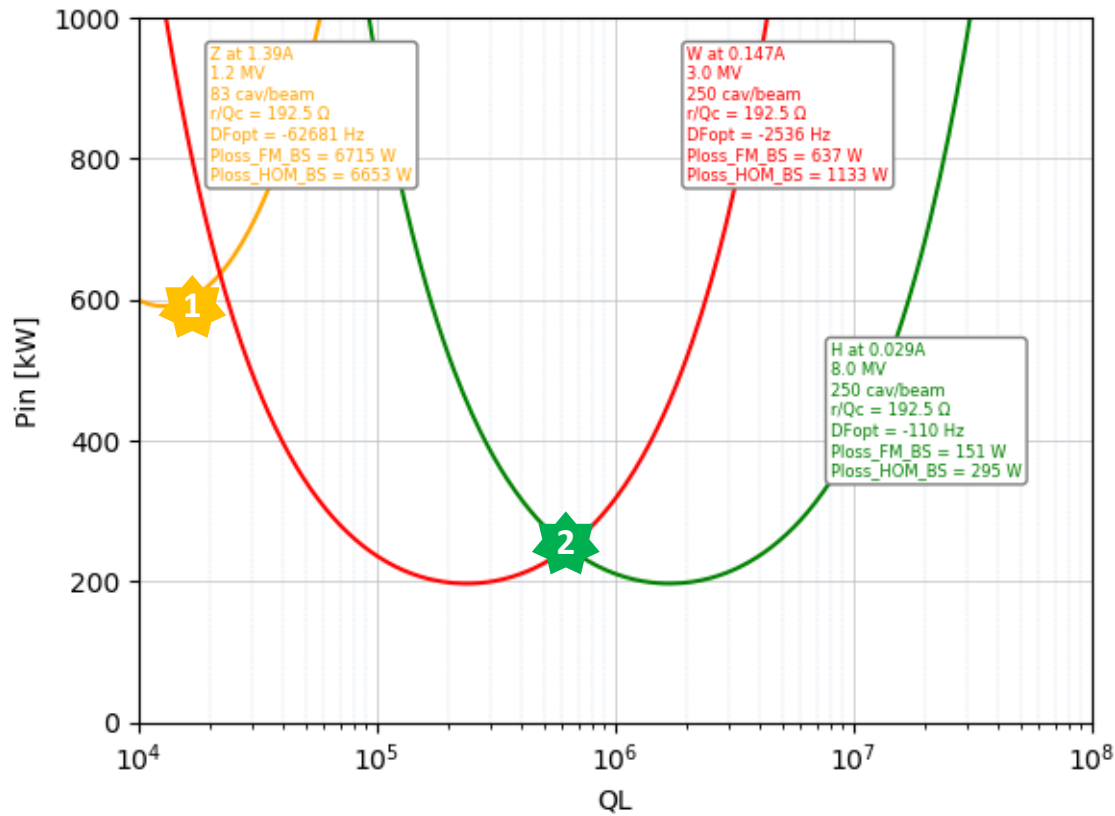

**2** Install 166 additional cavities per beam (total of 250 cavities per beam)

- for the W energy:  $V_{acc} = 3$  MV,  $E_{acc} = 6$  MV/m
- for the H energy:  $V_{acc} = 8$  MV,  $E_{acc} = 16$  MV/m
- A common loaded quality factor of  $QL = 6.4 \times 10^5$  is necessary, and the CW RF power levels is only about 300 kW per cavity
- Each existing 600 kW RF power sources can feed now two cavities

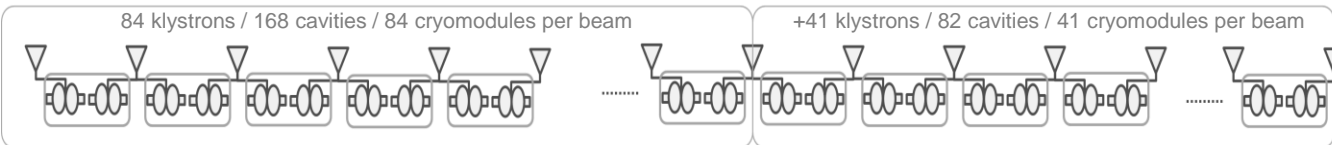
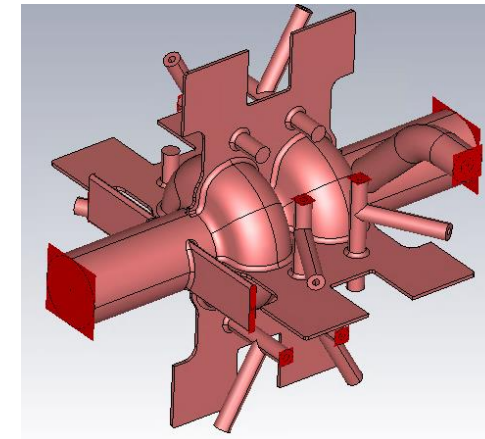

# Z operation with H machine

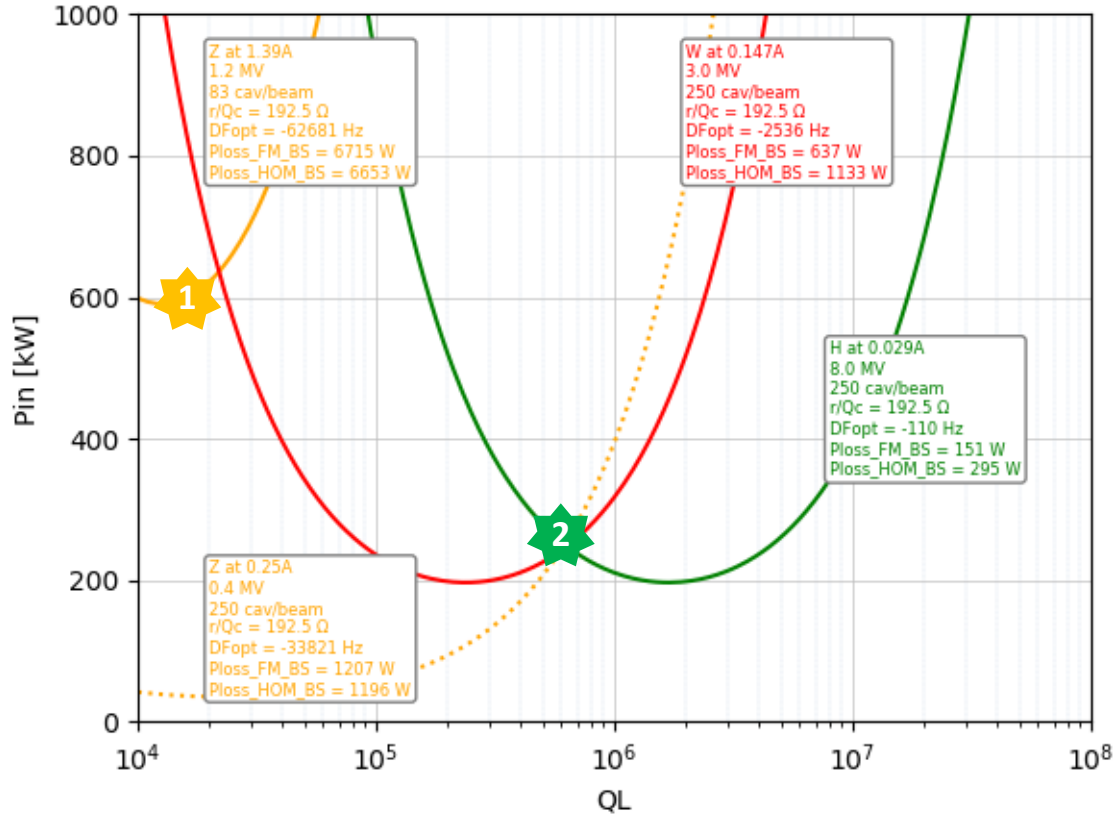

- Operating this RF system at the Z energy for **physics calibration** is possible, with a drastic reduction of beam current.
- The **250 mA** mentioned on this plot shall be considered as a high limit, since the detailed analysis of the cavity-beam interaction are not yet included
- The beam stability criteria will define the maximum beam current and most appropriate accelerating voltage, while keeping the RF power below 300 kW and the loaded Q factor as close to  $6.4 \times 10^5$

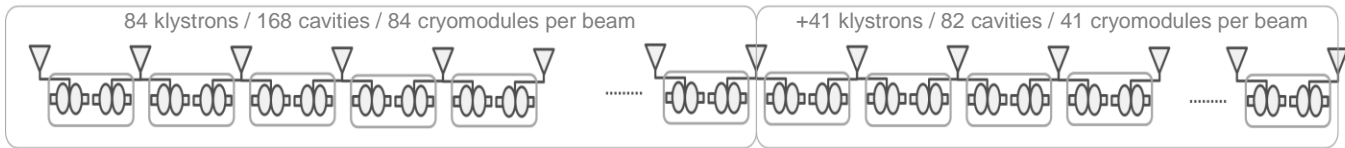

# SWELL cavity for ttb2 option

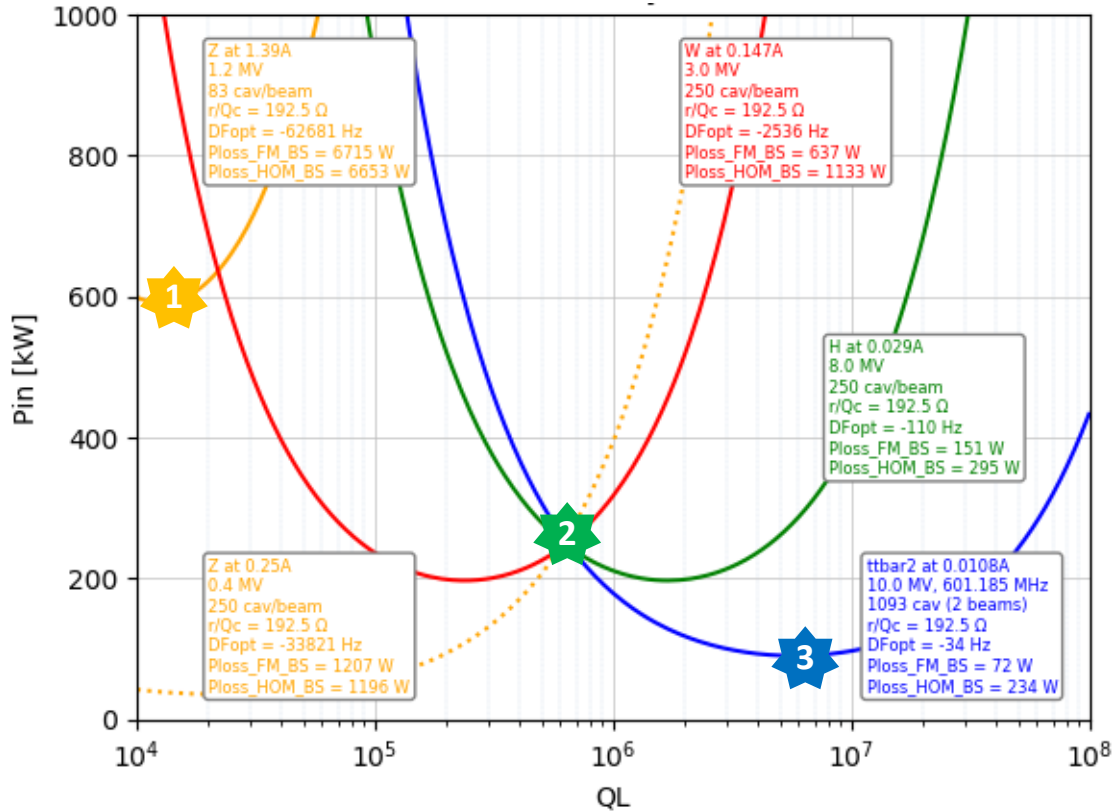

- 3 **Install 300 additional cavities per beam and re-align them for ttb energies**
  - $V_{acc} = 10$  MV,  $E_{acc} = 20$  MV/m
  - It corresponds to  $E_{pk} = 57.2$  MV/m,  $B_{pk} = 114.4$  mT  
 $\rightarrow$  ultimate working point for the SWELL cavity
  
- **The already installed 250 cavities per beam are compatible with ttb2 option**
  
- **“Standard” elliptical cavities (with 4 or 5 cells) and solid state amplifiers could certainly be considered**

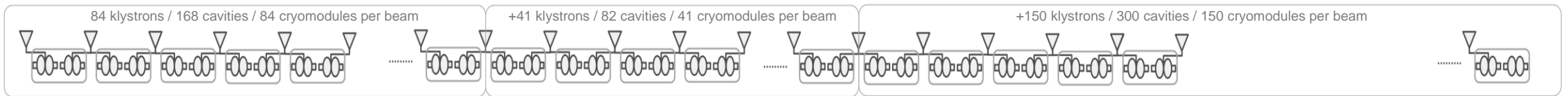

# 1.3 GHz single cell SWELL

- a SWELL version of the “standard” 1.3 GHz single cell SRF cavity has been designed
  - ✓ Derived from Tesla shape cavity
  - ✓ Simplified geometry (closed slots)
- RF Error studies and multipacting analysis are in progress

Parameters	Values
F (GHz)	1.301
R/Q linac ( $\Omega$ )	122.9
Lacc (mm)	115.3
Epk/Eacc	<b>2.01</b>
Bpk/Eacc	<b>4.61</b>
G ( $\Omega$ )	265.56

**F. Peauger,  
I. Syrathev**

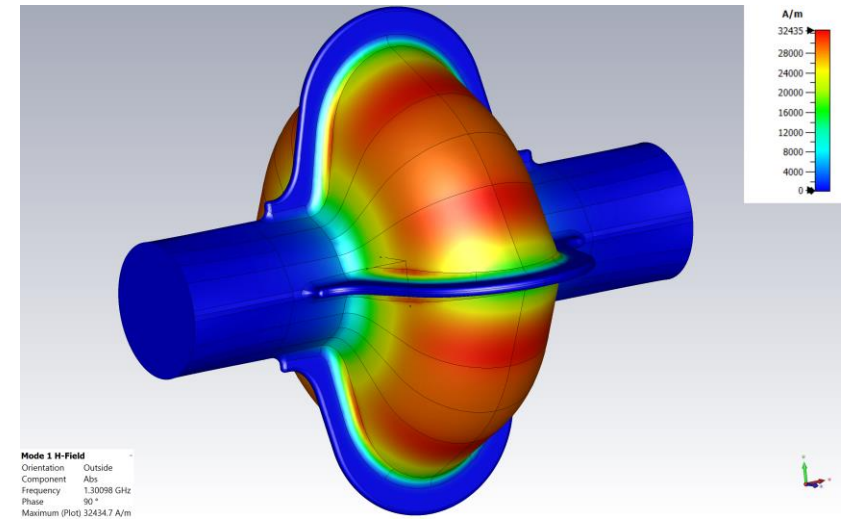
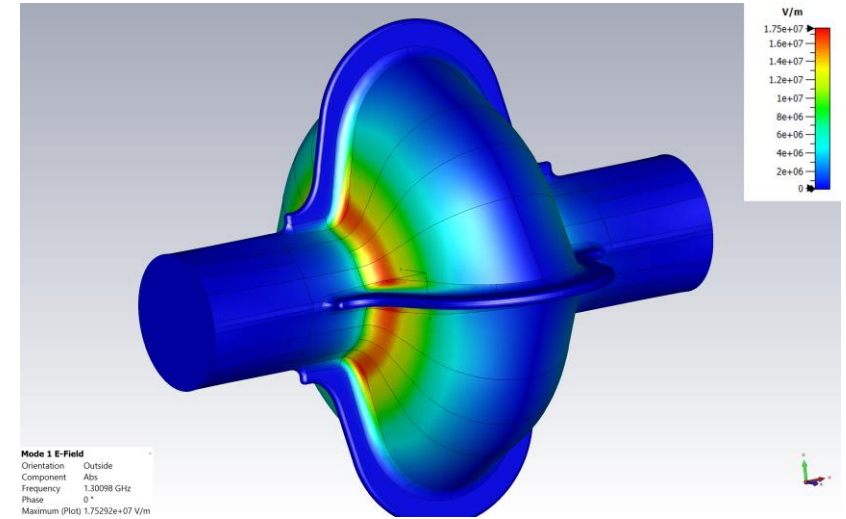

# 1.3 GHz single cell SWELL

- The cavity is made of 4 copper quadrants machined, niobium coated and assembled in clean room
- Thermal and mechanical design of the cavity are in progress
- RF Test at 4.5 K and 2 K are foreseen in SM18 at CERN

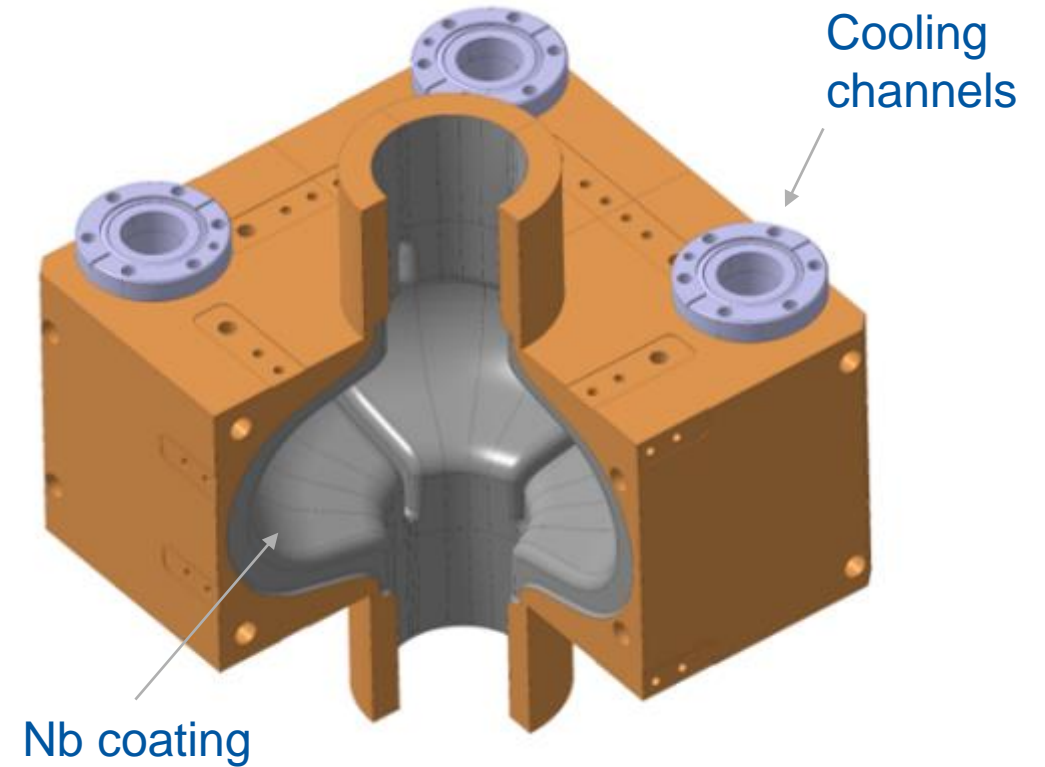

M. Timmins, O. Capatina, S. Atieh, G. Rosaz, M. Therasse, V. Parma

- A working solution has been confirmed for the RF system baseline design, with a traditional approach
- This baseline has been challenged by various alternative - and innovative - cavity design
  - HWR
  - QWR
  - Re-entrant
  - Spoke
  - Slotted elliptical
- The SWELL cavity has been identified by far as the most promising alternative option which offers an opportunity to operate with a **single cavity type** for (almost) all the FCCee energy options
  - SWELL technology is compatible with Nb/Cu coating technology
  - SWELL technology is “seamless” by its nature (no assembly joints on high electromagnetic field regions)
- A staged cryomodules and klystrons installation scheme has been proposed, optimizing the overall RF configuration and minimizing the installation shutdowns
- The frequency choice of 600 MHz is mainly driven by the SWELL cavity, which is not (yet) a proven technology. The study of a back-up solution is envisaged in collaboration with JLAB and the EIC project
- A “demo SWELL cavity” at 1.3 GHz will be built and tested at cryogenic temperature

**Thank you for your attention**