



Heavy Flavour Experiment Lecture 1

Johannes Albrecht
(TU Dortmund)

30. & 31. August 2013

- I have taken inspiration from many recent results and conference talks
- Many thanks to those who (un)knowingly helped me
 - Vava Gligorov & Barbara Storaci (discussion leaders)
 - T. Gershon, V. Gibson, S. Hansmann-Menzemer, U. Uwer, F. Teubert, T. Nakada, A. Shires, S. Wandernoth ...
- This is a school talk, not an overview of the field
 - **the topics presented are a subjective choice, covering fewer topics in more detail**
 - For **complete overviews**, look at recent conferences, e.g.
 - EPS13: <https://indico.cern.ch/getFile.py/access?contribId=864&sessionId=28&resId=1&materialId=slides&confId=218030>
 - LHCC: <http://indico.cern.ch/categoryDisplay.py?categId=3427>
 - FPCP: <http://fpcp2013.if.ufrj.br/fpcp-2013/>

- Lecture 1:
 - Introduction to “heavy flavour physics”
 - The Experiments:
Flavour physics at e^+e^- and at hadron colliders
 - Precision measurements of the quark mixing matrix
- Lecture 2:
 - “Golden modes for New physics searches” – loop zoology

- High **energy**:
“real” new particles can be produced and discovered via their decays
- High **precision**:
“virtual” new particles can be discovered in loop processes

**Direct and indirect searches are both needed,
both equally important,
and complement each other**

Contribution of New Physics as correction to the Standard Model

Standard Model

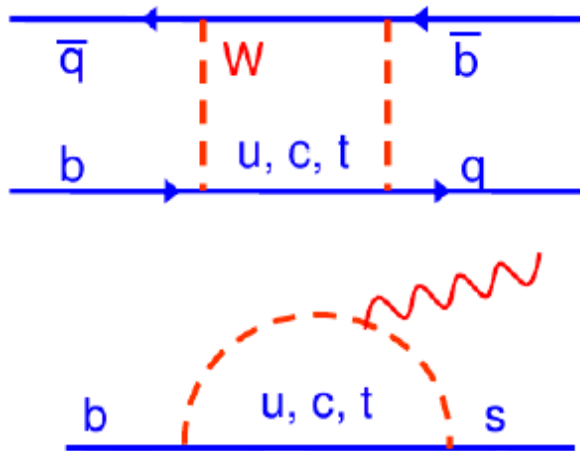

Contribution of New Physics as correction to the Standard Model

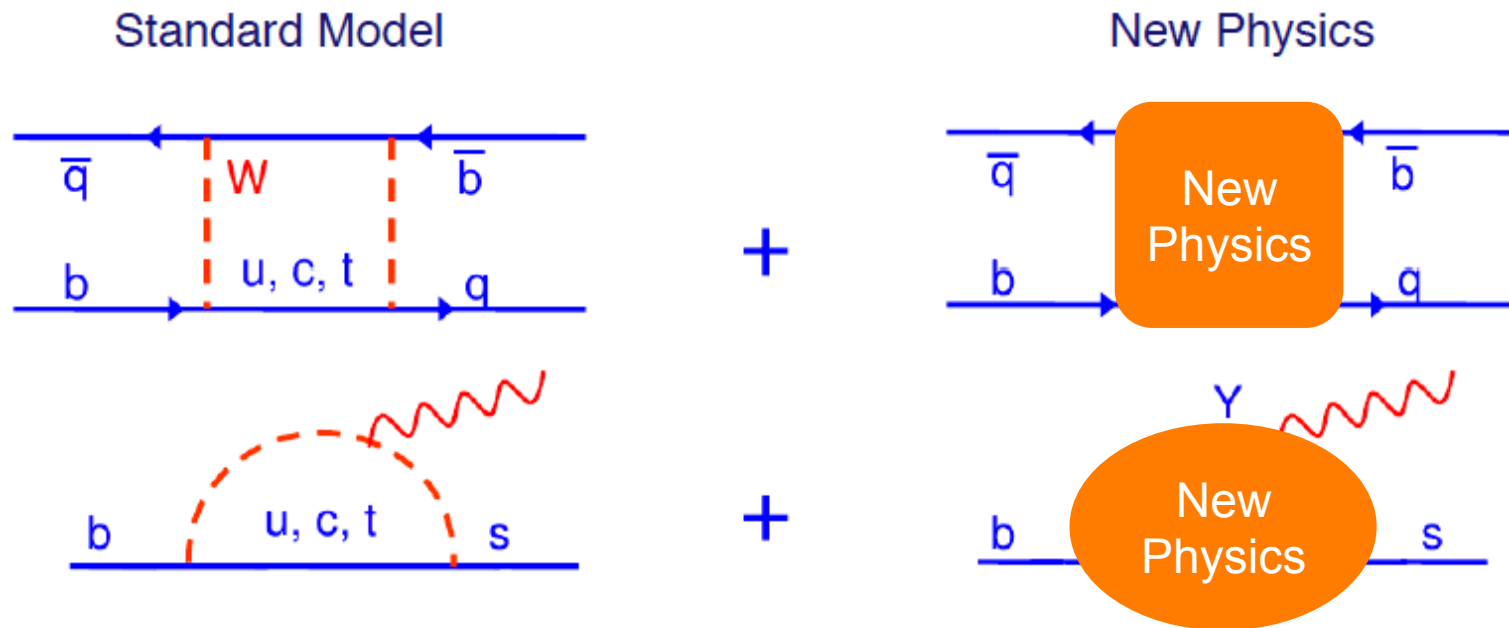

$$\mathcal{A}_{BSM} = \mathcal{A}_0 \left(\frac{C_{SM}}{m_W^2} + \frac{C_{NP}}{\Lambda^2} \right)$$

What is the scale of Λ_{NP} ? What is its coupling C_{NP} ?

GIM Mechanism

Observed branching ratio $K^0 \rightarrow \mu\mu$

$$\frac{BR(K_L \rightarrow \mu^+ \mu^-)}{BR(K_L \rightarrow \text{all})} = (7.2 \pm 0.5) \cdot 10^{-9}$$

In contradiction with theoretical expectation in the 3-Quark Model

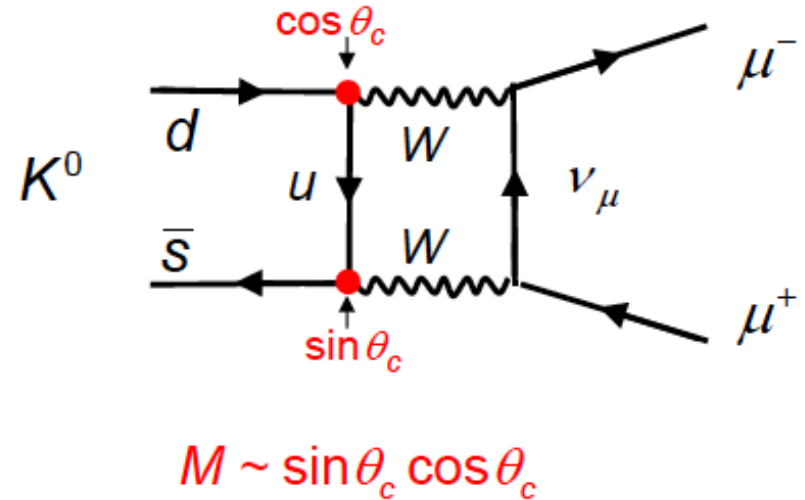

GIM Mechanism

Observed branching ratio $K^0 \rightarrow \mu\mu$

$$\frac{BR(K_L \rightarrow \mu^+ \mu^-)}{BR(K_L \rightarrow \text{all})} = (7.2 \pm 0.5) \cdot 10^{-9}$$

In contradiction with theoretical expectation in the 3-Quark Model



Glashow, Iliopolus, Maiani (1970):

Prediction of a 2nd up-type quark, additional Feynman graph cancels the “u box graph”.

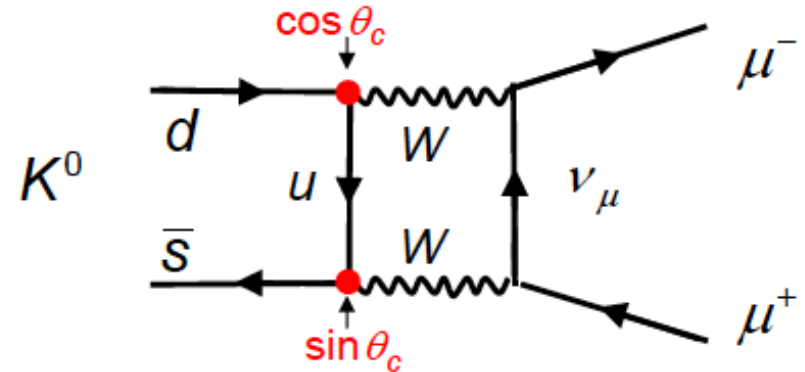

$$M \sim \sin \theta_c \cos \theta_c$$

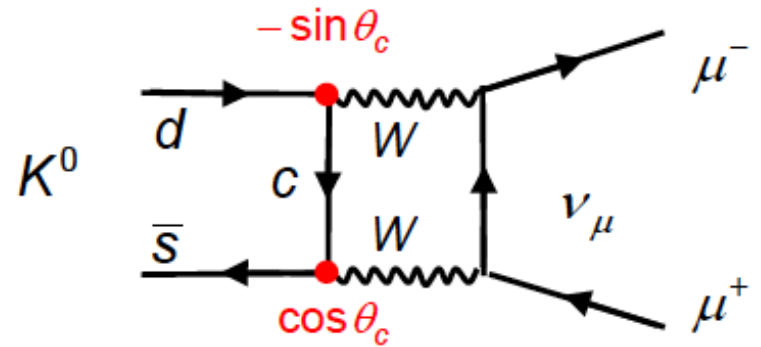

$$M \sim -\sin \theta_c \cos \theta_c$$

ARGUS Experiment, 1987:

Observation of B^0 - \bar{B}^0 Oscillation



$m_t > 50 \text{ GeV}$

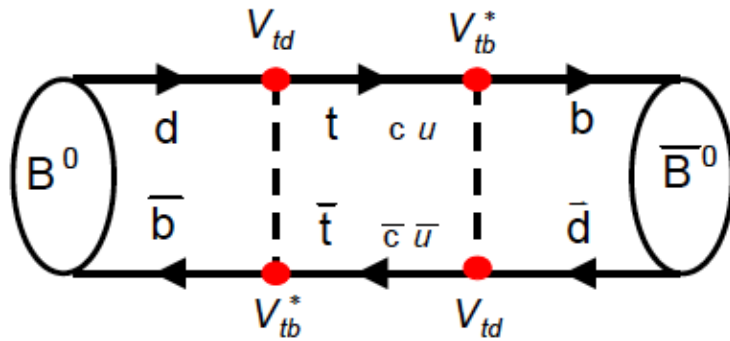

ARGUS Experiment, 1987:

Observation of B^0 - \bar{B}^0 Oscillation

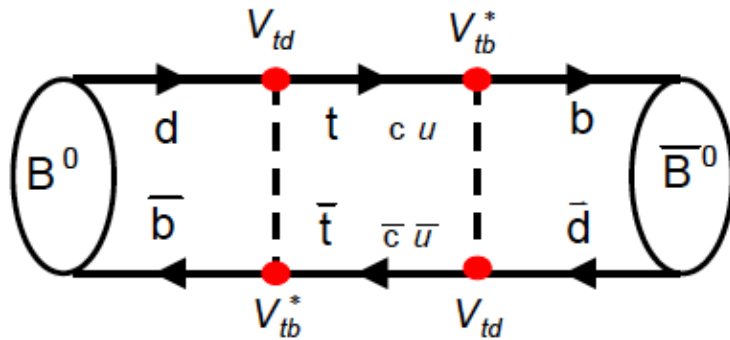

$m_t > 50$ GeV

Precision electro-weak Physics at the Z

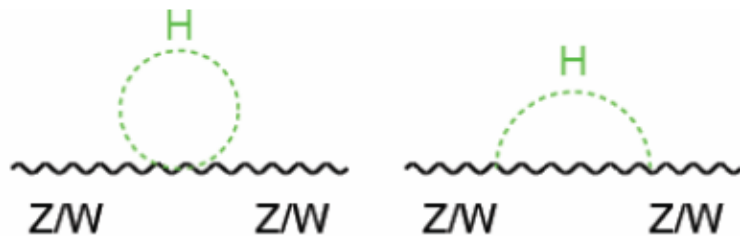

LEWWG March 2007

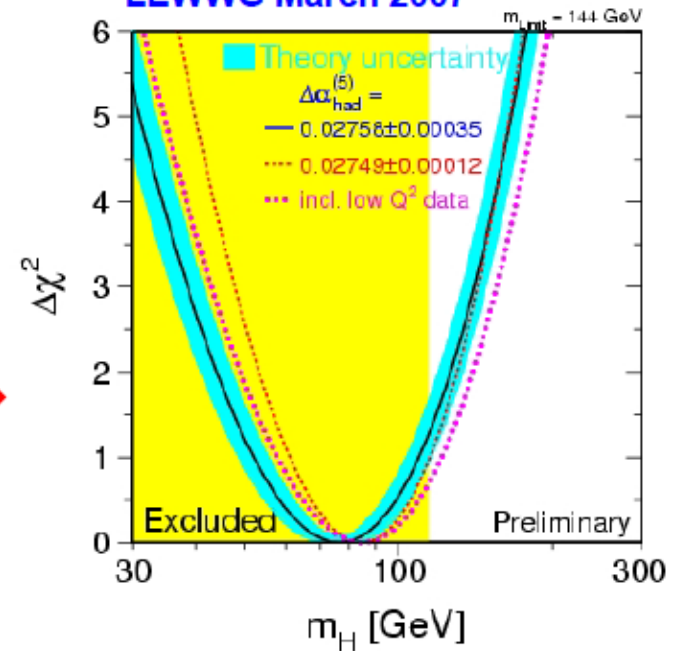

$m_{\text{H}} < 144$ GeV (95% C.L.)

- Before the LHC, $\lambda_{\text{NP}} \sim 1\text{TeV}$ was expected
 - Fine tuning at EW scale reduced
 - But: NP effects expected in flavour physics → NP flavour problem
 - Ad-hoc solution: introduce Minimal Flavour Violation to avoid fine tuning in the flavour sector
 - After Higgs discovery: scale of New Physics fully unclear

- Before the LHC, $\lambda_{NP} \sim 1\text{TeV}$ was expected
 - Fine tuning at EW scale reduced
 - But: NP effects expected in flavour physics → NP flavour problem
 - Ad-hoc solution: introduce Minimal Flavour Violation to avoid fine tuning in the flavour sector
 - After Higgs discovery: scale of New Physics fully unclear

- So far: no significant sign of New Physics
 - The scale for NP get pushed higher
 - NP flavour problem reduced
 - chances to see NP in the flavour sector have increased (hypotheses like MFV look less likely)

arXiv:1205.7091, arXiv:1205.2671

Importance of Flavour

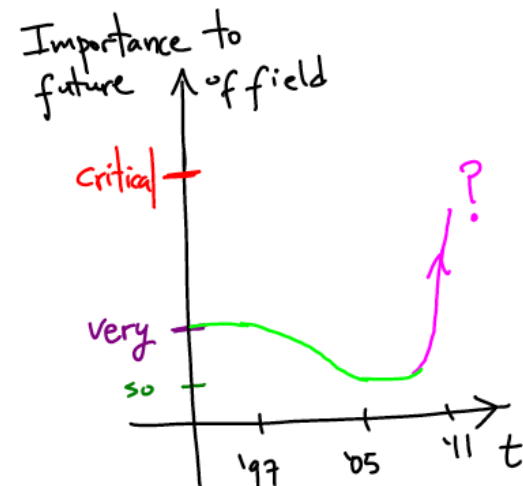

N. Arkani-Hamed

Intensity frontier workshop

- Focus in these lectures will be on
 - Flavour changing interactions of **charm** and **beauty quarks**
- But quarks feel the strong interaction and hadronize
 - Various different beauty hadrons
 - Many, many possible decays to different final states
 - Hadronization introduces great complications,
 - BUT also increases the observability of CP violation effects
- Many aspects of flavour physics left out in this lecture
 - Neutrino physics: have own phenomenology
 - Light quark flavour physics
 - Charged lepton physics
 - Top-flavour physics: different, as the top does not hadronize

- The beauty quark ...
 - Is the heaviest quark that forms hadronic bound states
→ high mass: many accessible final states
 - Must decay outside the 3rd family
 - All decays are CKM suppressed
 - Long lifetime ($\sim 1.6\text{ps}$)
- Beauty-decays:
 - Dominant decay process: “tree”
 $b \rightarrow c$ transition
 - Very suppressed “tree” $b \rightarrow u$ transition
 - FCNC “penguin” $b \rightarrow s$ and $b \rightarrow d$ transitions
 - Flavour oscillations ($b \rightarrow t$ “box” diagrams)
 - CP violation – expect large CP asymmetries in some B decays

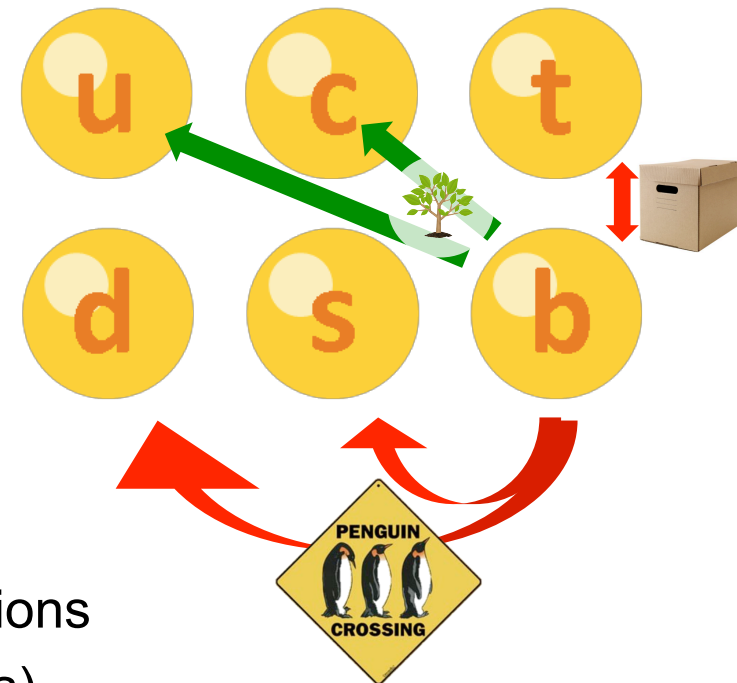



BABAR
1999-2008



2001-2009



2008





BELLE
1999 - 2010

Asymmetric e^+e^- - collider experiments
 pp and $p\bar{p}$ collider experiments

B-factories (BaBar & Belle)

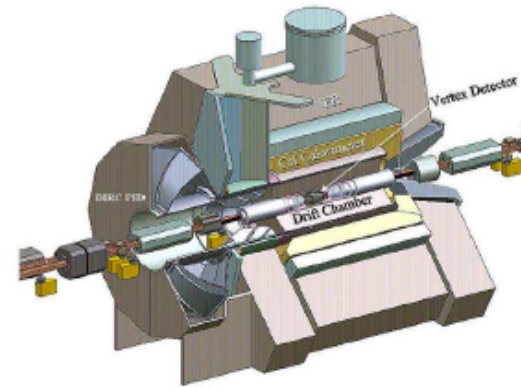
- e^+e^- experiment at SLAC / KEK
- Dedicated B-physics experiment



General purpose detectors (ATLAS, CMS, CDF, D0)

- Proton colliders @ CERN / Tevatron
- 4π multi purpose detectors

CDF II Detector

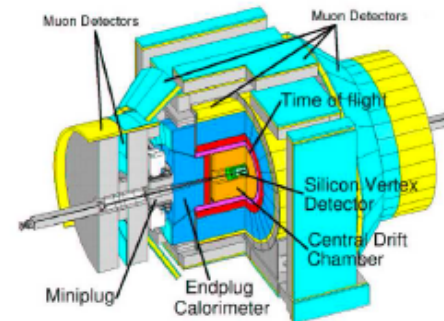

LHCb

- Proton colliders @ CERN
- Dedicated B-physics experiment

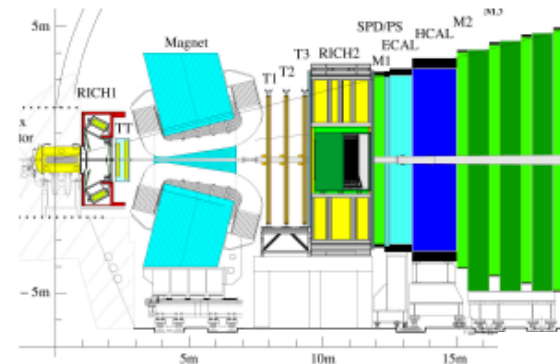

Experimental environment: e^+e^-

Lepton collider
(collision of pointlike objects)



Hadron collider
(collision of extended objects)



[Karl Jakobs]

PEP-II at SLAC
 9.0 GeV e^- on 3.1 GeV e^+

KEKB at KEK
 8.0 GeV e^- on 3.5 GeV e^+

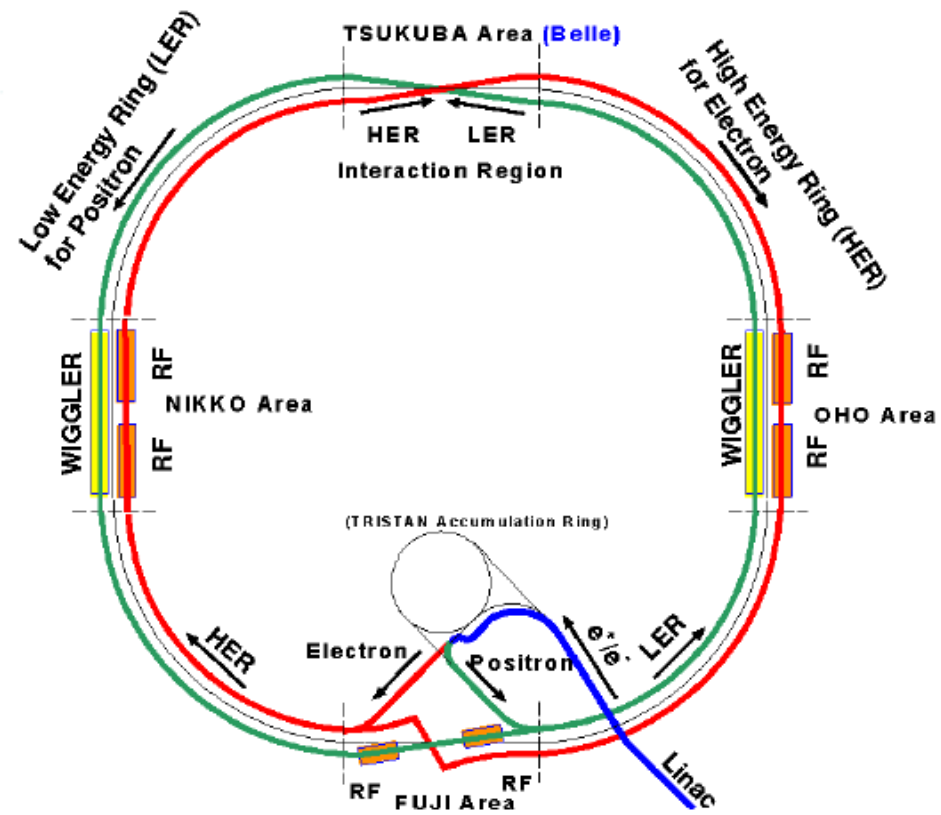
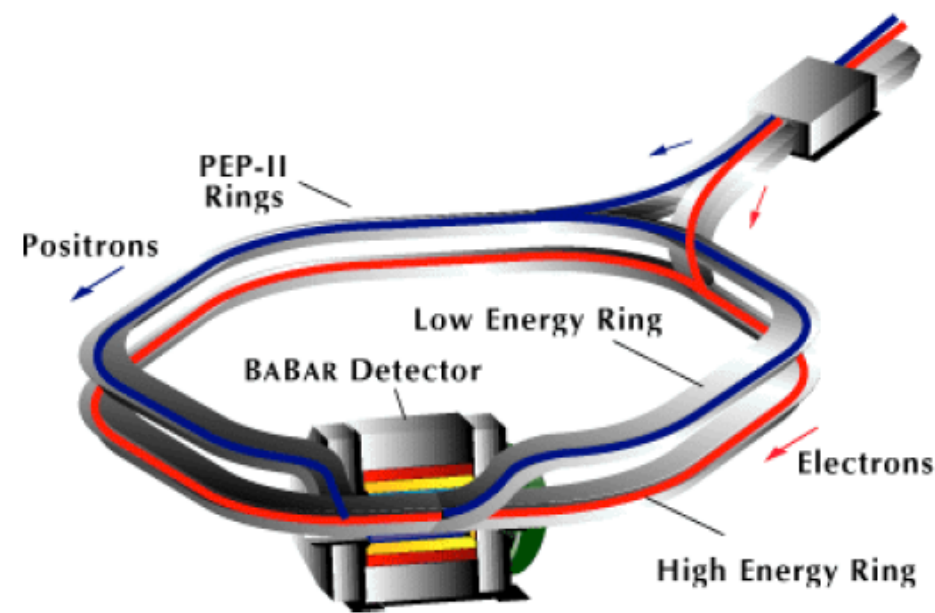

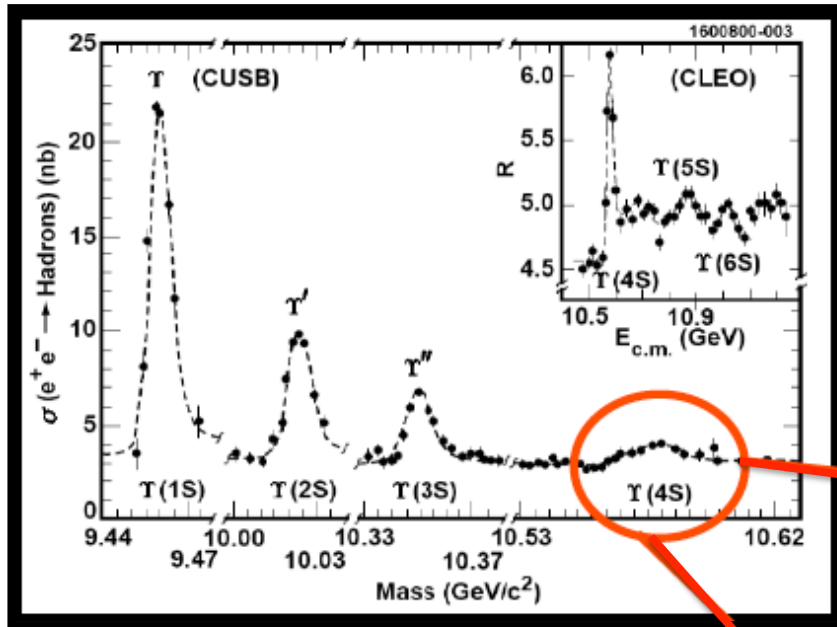

Cleanest way to produce B mesons:
 e^+e^- collisions at

$$\sqrt{s} = 10.58 \text{ GeV}$$

$\sim 1.1 \text{ M BB pairs per fb}^{-1}$

$$\sigma_{bb} / \sigma_{\text{continuum}} \sim 1/3$$

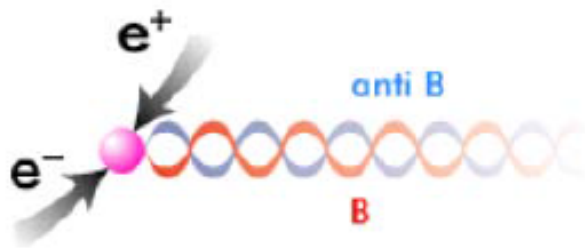

BB pair is produced in a coherent state
 \rightarrow two B mesons evolve until one decays

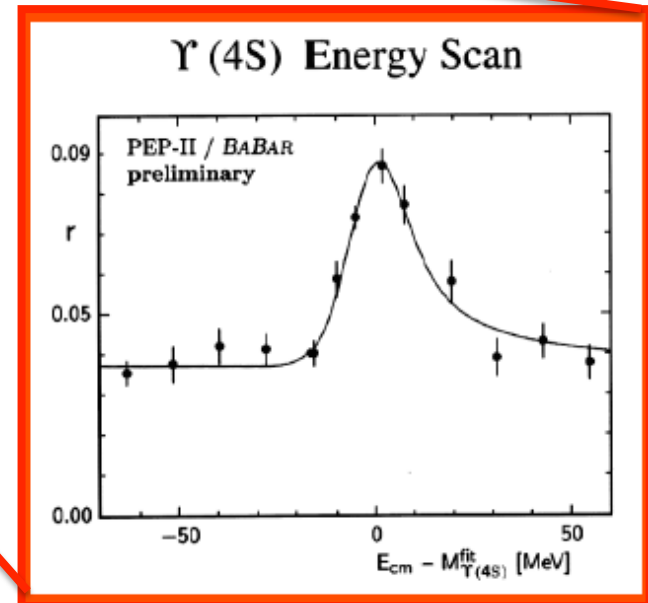

- Symmetric collider: B-mesons produced \sim at rest
 - Short lifetime make flight distance unmeasurably small

- Asymmetric collider (KEKB, PEP-II):
with boost $\beta\gamma \sim 0.6$

$$\Delta t \approx \frac{\Delta z}{\langle \beta\gamma \rangle c}$$

$$\langle |\Delta z| \rangle \approx 200 \mu\text{m}$$

- Beam energy precisely known \rightarrow constrain B kinematics

$$\Delta E \equiv E_B^* - E_{beam}^*$$

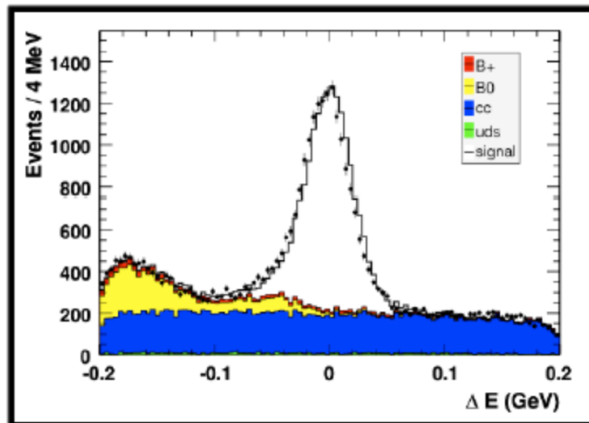

$$m_{ES} \equiv \sqrt{E_{beam}^{*2} - p_B^{*2}}$$

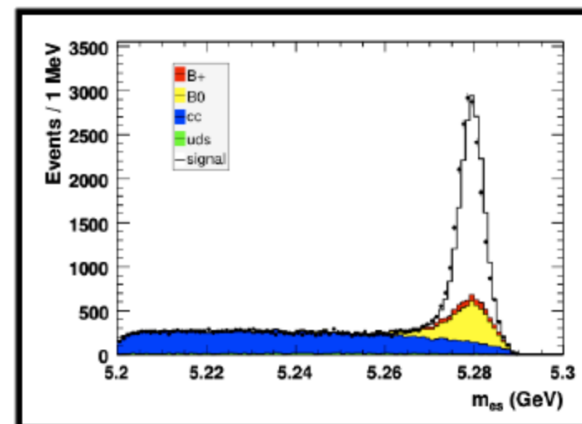

Experimental environment: pp (or $p\bar{p}$)

Lepton collider
(collision of pointlike objects)



Hadron collider
(collision of extended objects)



[Karl Jakobs]

- Protons are complicated objects
 - Valence & sea quarks, gluons
- Available energy of “proton” collision depends on partons

$$s' = x_1 \cdot x_2 \cdot s$$

x_i = Bjorken x
(fractional momentum)
of parton

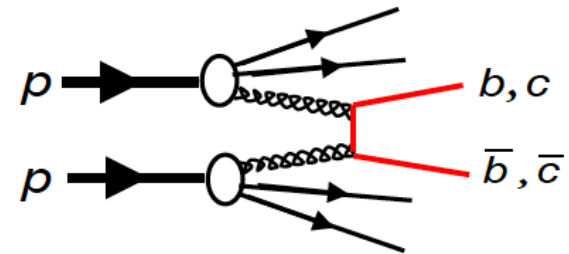
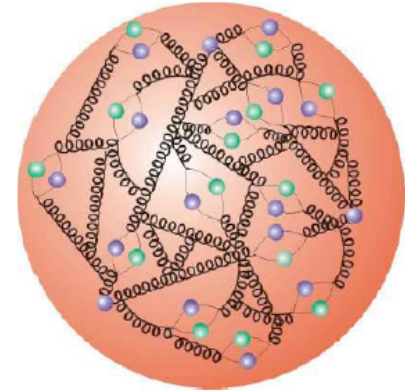

- Energy of particular collision unknown, but distributions known
 - hadron colliders “scan” a wide energy range
 - Average $s' \sim 0.1 s$
 - Dominant process @ LHC: gluon fusion

- B hadron mass $\sim 5 \text{ GeV}$
 - asymmetric x-values
 - strongly boosted ($\beta\gamma \sim 100$)
 - average flight length $\sim 7 \text{ mm}$
- Boost allows time dependent analyses of fast B_s mixing
- B hadron admixture:
 - 40% B^0
 - 40% B^+
 - 10% B_s
 - 10% Λ_b
 - $<1\%$ others (B_c, B^*, B^{**}, \dots)

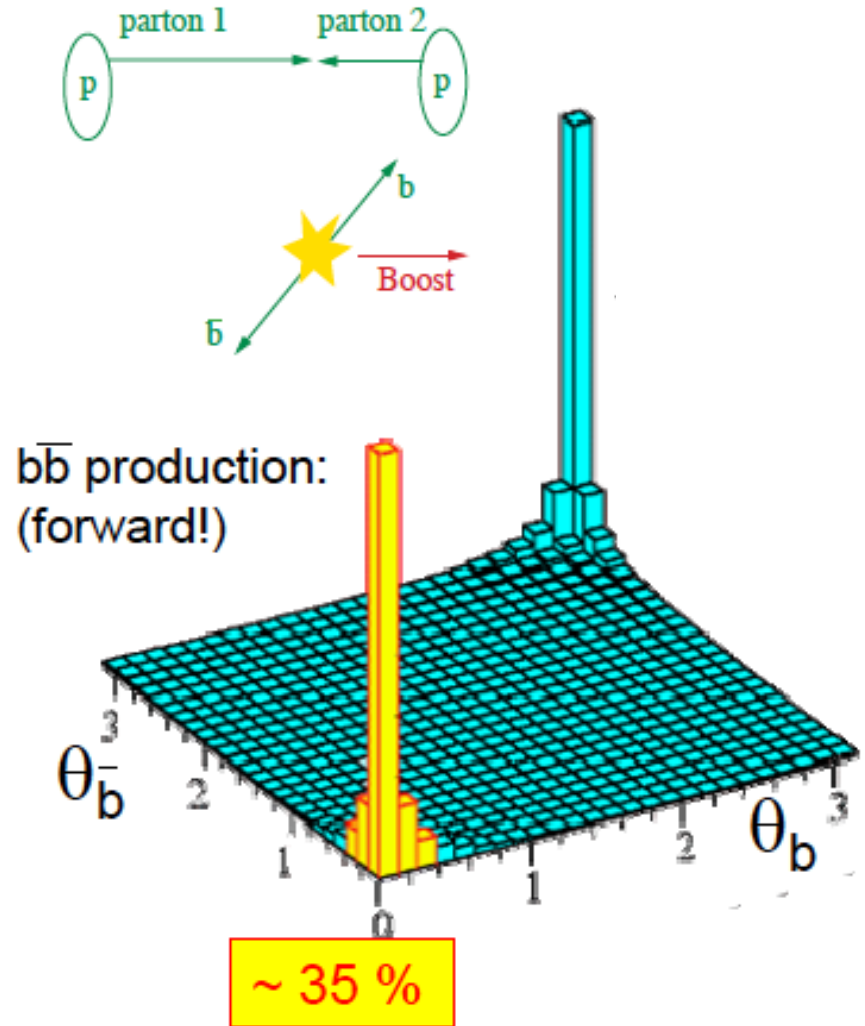

ATLAS / CMS

- Central detectors, $|\eta| < 2.5$
- **High Luminosity ($> 10^{34} \text{cm}^{-2} \text{s}^{-1}$)**
→ **high pileup ~ 20**
- Trigger
 - Relatively low rate ($\sim 200\text{-}400 \text{Hz}$)
 - High PT muon triggers
- Analysis
 - Mostly modes with dimuons
 - Limited flavour tagging
- Particle identification
 - Excellent muon ID
 - Limited K / π separation

LHCb

- Forward spectrometer, $1.9 < \eta < 5$
- **Lower Luminosity ($4 \times 10^{32} \text{cm}^{-2} \text{s}^{-1}$)**
→ pileup ~ 1.5
- Trigger
 - **High trigger rate ($\sim 5 \text{kHz}$)**
 - **Muon & hadron** triggers, softer thresholds
 - **Large bandwidth for charm**
- Analysis
 - Hadronic and low M modes accessible
 - Excellent flavour tagging & σ_t
- Particle identification
 - Excellent muon ID
 - Dedicated RICH PID (K / π)

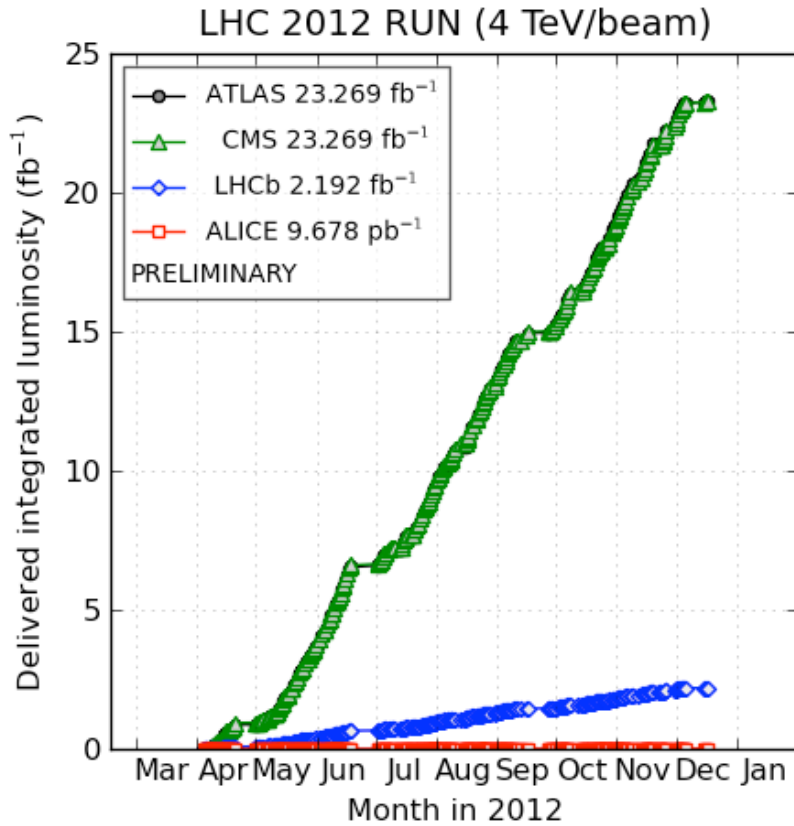

(generated 2013-01-29 18:28 including fill 3453)

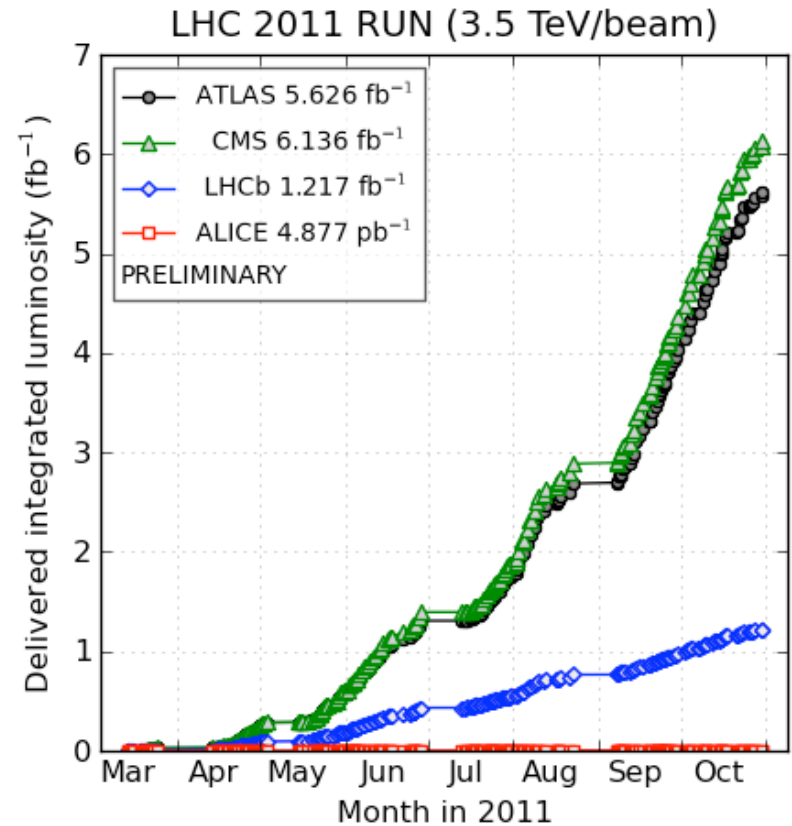

(generated 2012-06-21 00:39 including fill 2267)

Full dataset: ATLAS = CMS = 10 * LHCb

$\Upsilon(1S), \Upsilon(2S), \Upsilon(3S)$

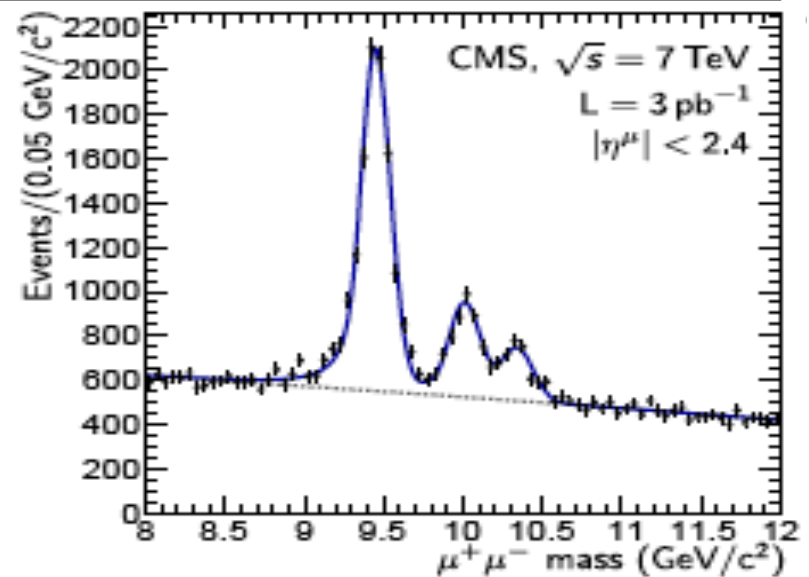
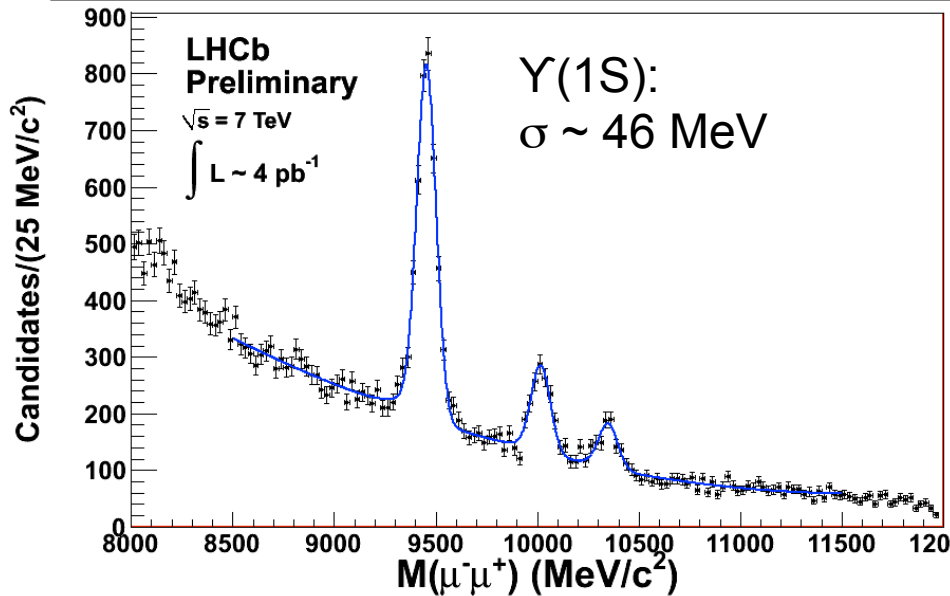

	momentum resolution	mass resolution $J/\psi \rightarrow \mu\mu$
LHCb	$\delta p/p = 0.4\text{-}0.6 \%$	13 MeV
CMS	$\delta p_t/p_t = 1\text{-}3 \%$	40 MeV
ATLAS	$\delta p_t/p_t = 5\text{-}6 \%$	71 MeV

Primary vertex resolutions (25 tracks):

	LHCb [μm]	ATLAS [μm]	CMS [μm]
$\sigma(x)$	15.8	60	20-40
$\sigma(y)$	15.2	60	20-40
$\sigma(z)$	76	100	40-60

Impact parameter (IP):

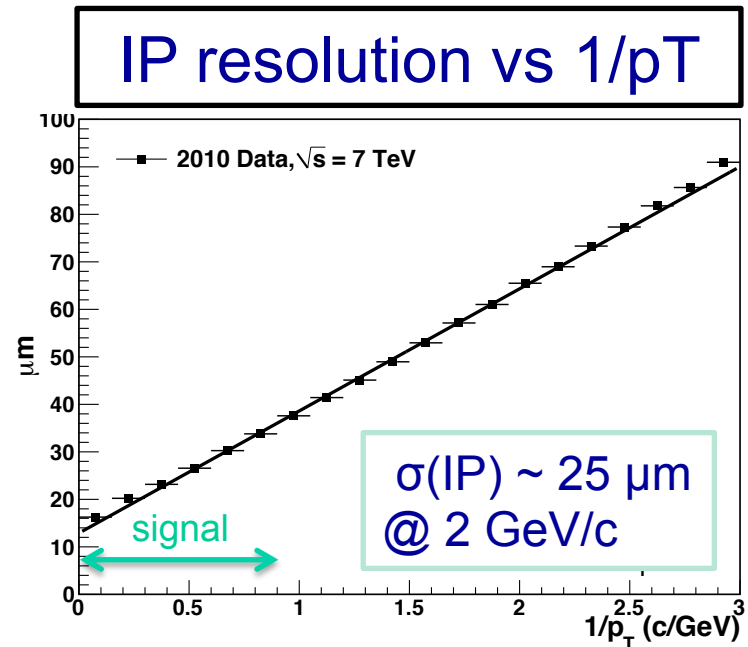
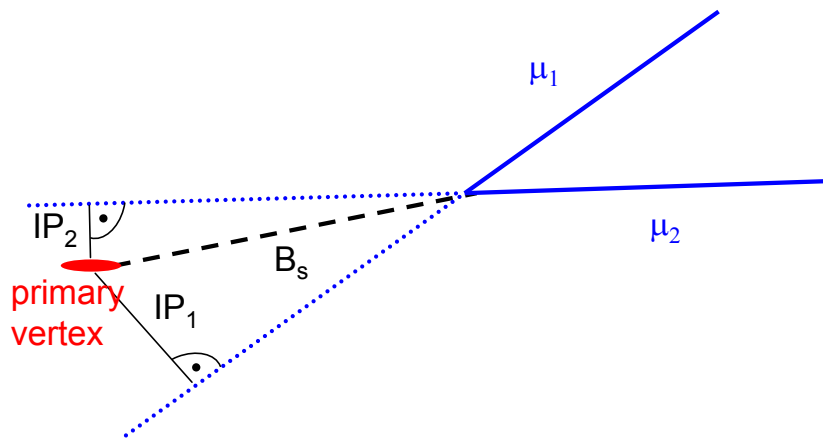

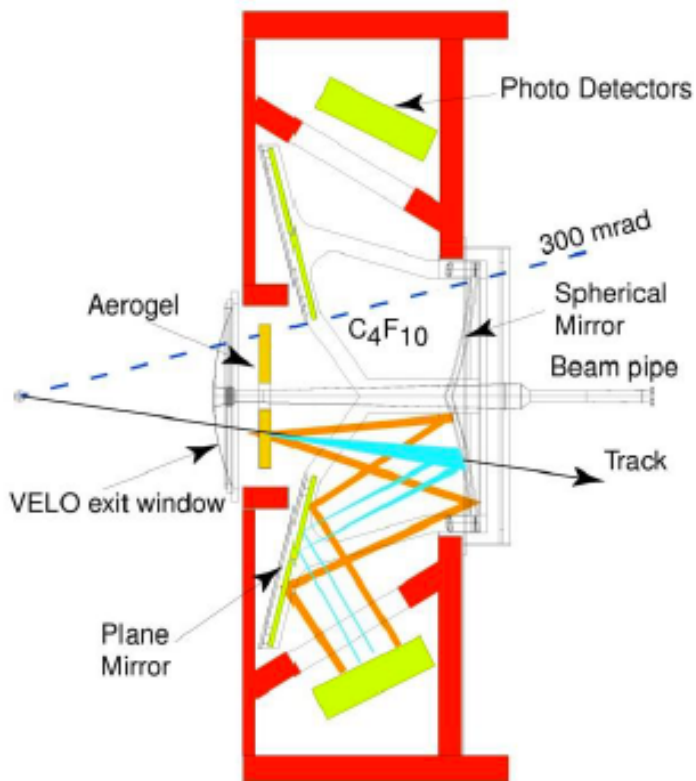

$$\cos \theta_c = \frac{1}{\beta n}$$

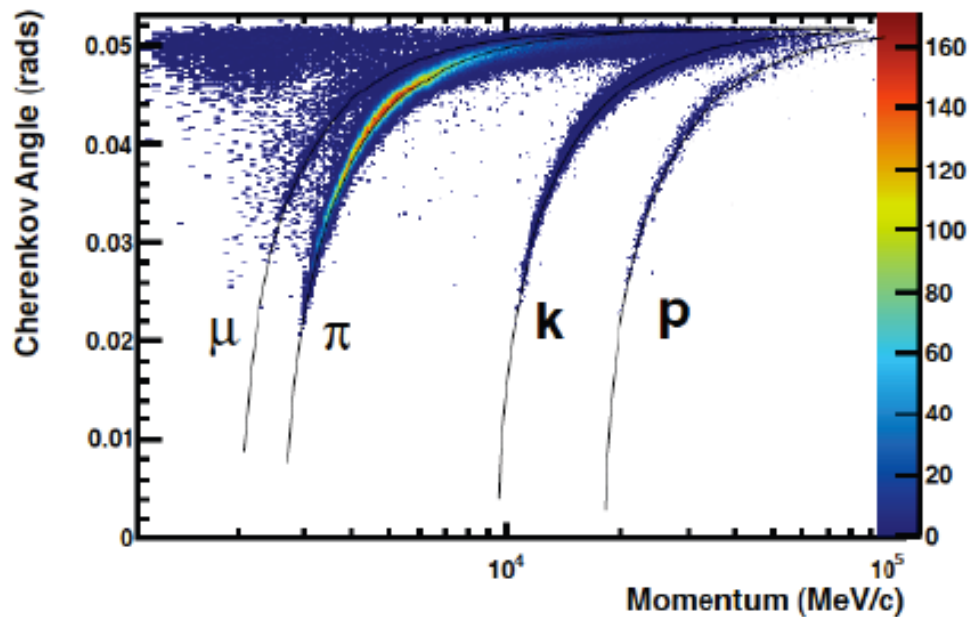

- The LHCb experiment is equipped with two Cherenkov detectors

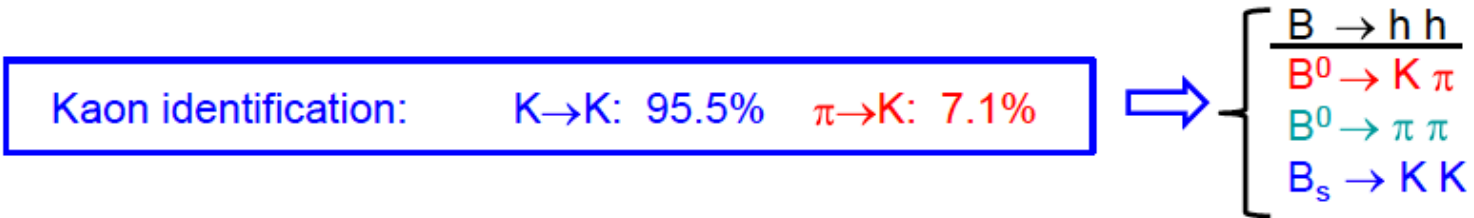

$B \rightarrow h^+ h^-$ without and with RICH Particle ID

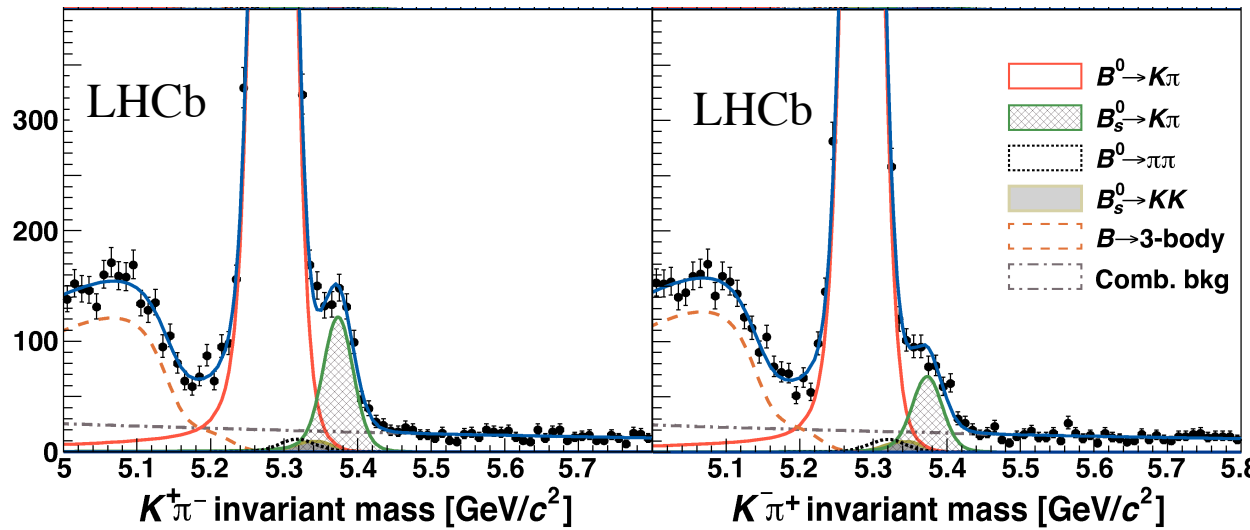
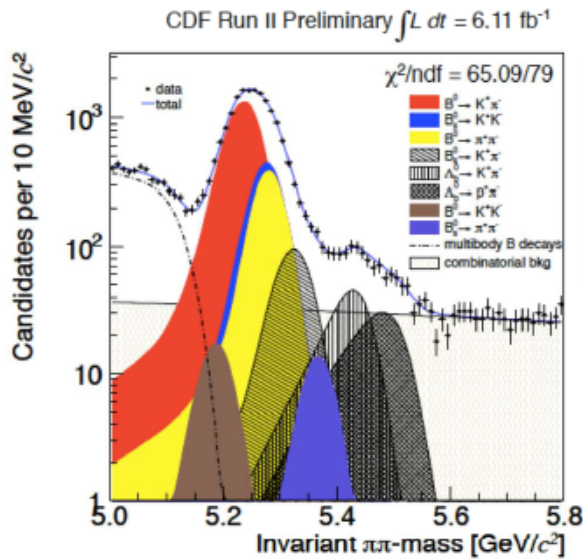

	BaBar / Belle (ee)	CDF / D0 (pp)	ATLAS / CMS (pp)	LHCb (pp)
\sqrt{s} [GeV]	10.58 (Y(4S))	1980	7000 / 8000	7000 / 8000
BB production	coherent BB state	Incoherent BB state		
σ_{bb} [μb] in acceptance	0.0011	6.3	75	94
L [fb^{-1}]	550 / ~ 1000	~ 10	~ 30	3
bb pairs in acceptance [10^{11}]	0.01	0.6	22	3

What does $1/\text{ab}$ mean?
 $N(\text{bb}) = \text{Lumi} * \text{x-section}$

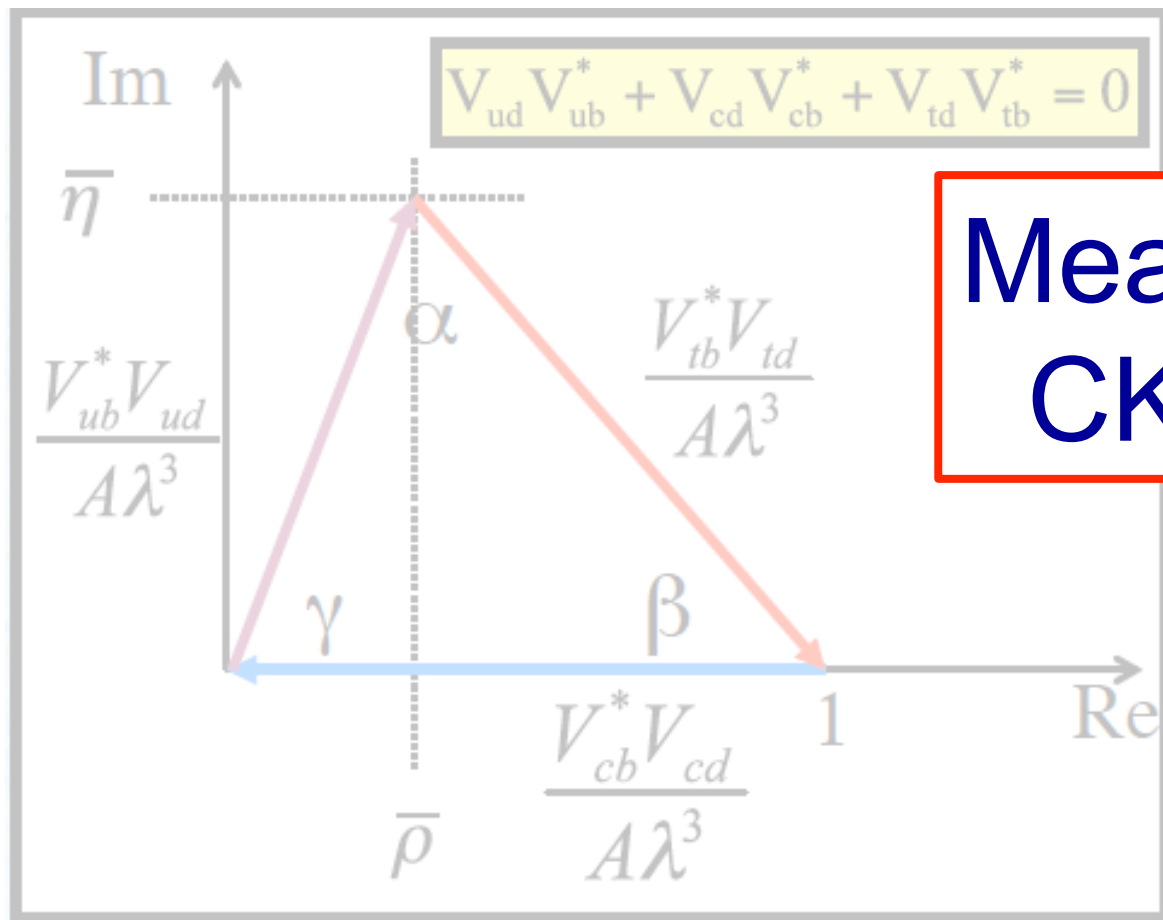

Measuring the CKM Matrix

Pick 3 measurements/quantities:

- CKM angle $\sin 2\beta$
- CKM angle γ
- B_s mixing frequency: Δm_s

[repetition from detailed discussion from David Straub yesterday]

V_{CKM} describes the rotation between weak (d' , s' , b') and mass eigenstates (d , s , b)

Quarks

$$\begin{pmatrix} d' \\ s' \\ b' \end{pmatrix} = \begin{pmatrix} V_{ud} & V_{us} & V_{ub} \\ V_{cd} & V_{cs} & V_{cb} \\ V_{td} & V_{ts} & V_{tb} \end{pmatrix} \begin{pmatrix} d \\ s \\ b \end{pmatrix}$$

Antiquarks

$$\begin{pmatrix} \bar{d}' \\ \bar{s}' \\ \bar{b}' \end{pmatrix} = \begin{pmatrix} V_{ud}^* & V_{us}^* & V_{ub}^* \\ V_{cd}^* & V_{cs}^* & V_{cb}^* \\ V_{td}^* & V_{ts}^* & V_{tb}^* \end{pmatrix} \begin{pmatrix} \bar{d} \\ \bar{s} \\ \bar{b} \end{pmatrix}$$

transition amplitude $\sim V_{ij}$

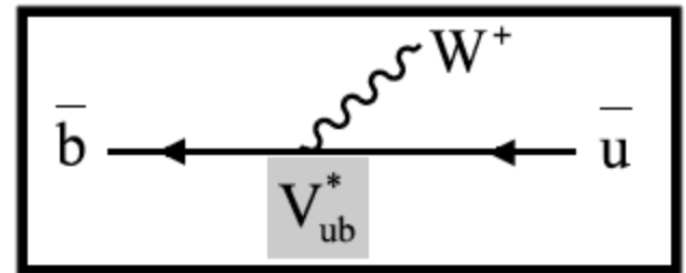
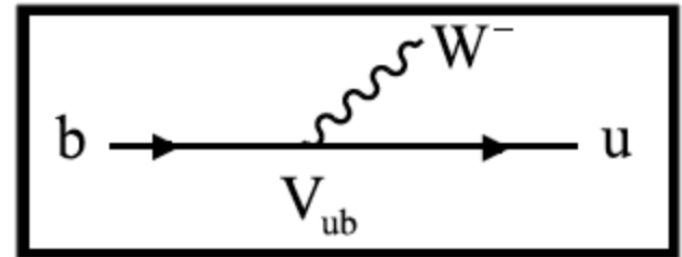

[repetition from detailed discussion from David Straub yesterday]

- CKM matrix is complex and unitary
- Four independent parameters
 - Fundamental constants of nature that must be measured
- Reflects hierarchy of quark transitions

$$\hat{V}_{\text{CKM}}^+ \hat{V}_{\text{CKM}} = 1$$

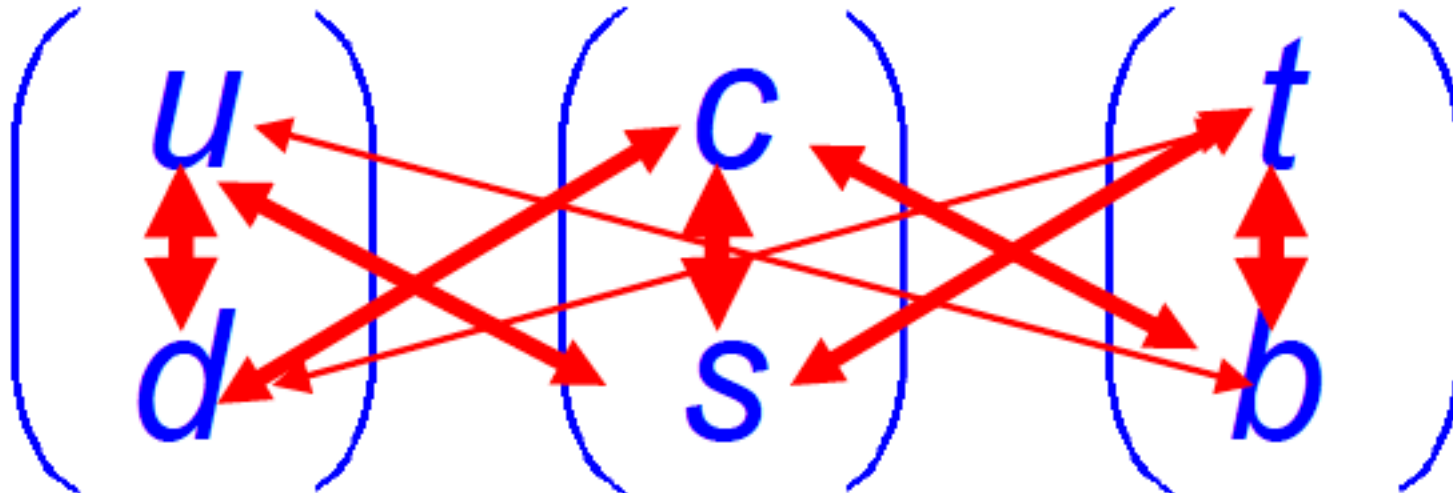

Unitarity triangles

[repetition from detailed discussion from David Straub yesterday]

CKM matrix is unitary:

$$V_{ud}V_{ub}^* + V_{cd}V_{cb}^* + V_{td}V_{tb}^* = 0 \quad (\text{db})$$

$$V_{us}V_{ub}^* + V_{cs}V_{cb}^* + V_{ts}V_{tb}^* = 0 \quad (\text{sb})$$

$$V_{ud}V_{us}^* + V_{cd}V_{cs}^* + V_{td}V_{ts}^* = 0 \quad (\text{ds})$$

$$V_{ud}V_{td}^* + V_{us}V_{ts}^* + V_{ub}V_{tb}^* = 0 \quad (\text{ut})$$

$$V_{cd}V_{td}^* + V_{cs}V_{ts}^* + V_{cb}V_{tb}^* = 0 \quad (\text{ct})$$

$$V_{ud}V_{cd}^* + V_{us}V_{cs}^* + V_{ub}V_{cb}^* = 0 \quad (\text{uc})$$

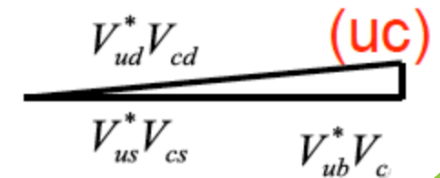
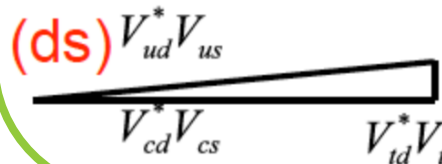
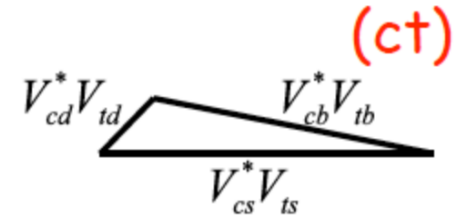
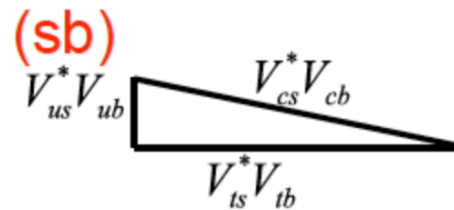
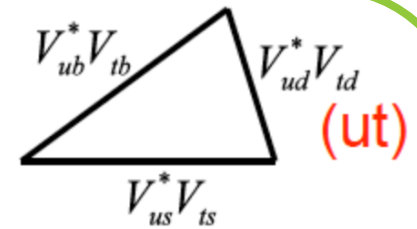
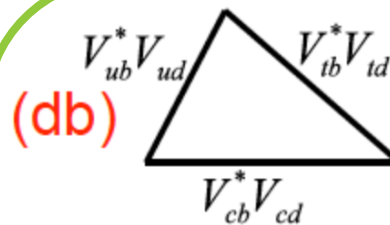

All 6 triangles have the same area, a measure of CPV in the SM

“The” CKM Unitarity Triangle

$$V_{ub}^* V_{ud} + V_{cb}^* V_{cd} + V_{tb}^* V_{td} = 0$$

- Pick a quark phase convention such that $V_{cb}^* V_{cd}$ is real
- Normalize all sides by $-V_{cb}^* V_{cd}$

$$\alpha = \arg \left(-\frac{V_{tb}^* V_{td}}{V_{ub}^* V_{ud}} \right)$$

$$\gamma = \arg \left(-\frac{V_{ub}^* V_{ud}}{V_{cb}^* V_{cd}} \right)$$

$$\beta = \arg \left(-\frac{V_{cb}^* V_{cd}}{V_{tb}^* V_{td}} \right)$$

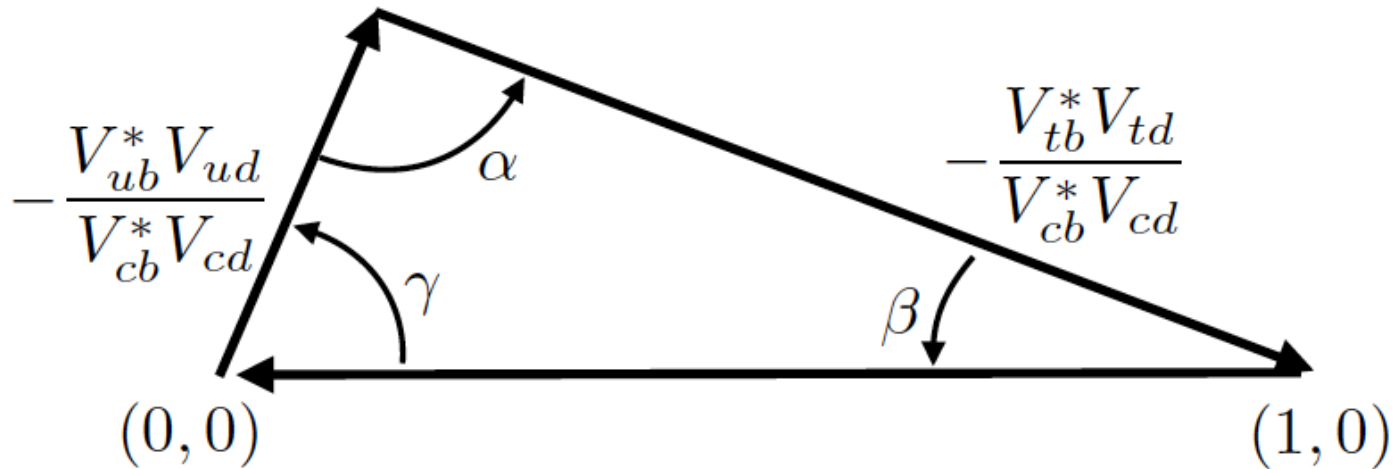

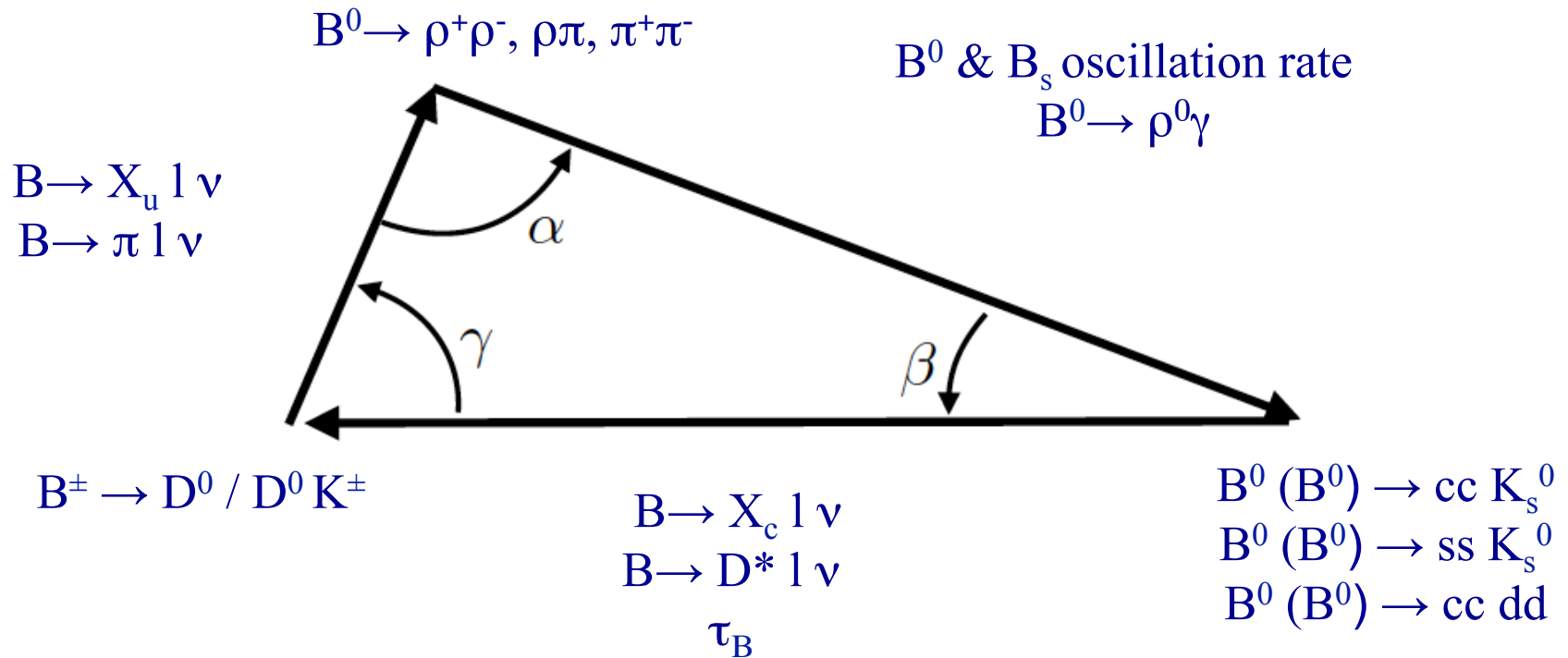

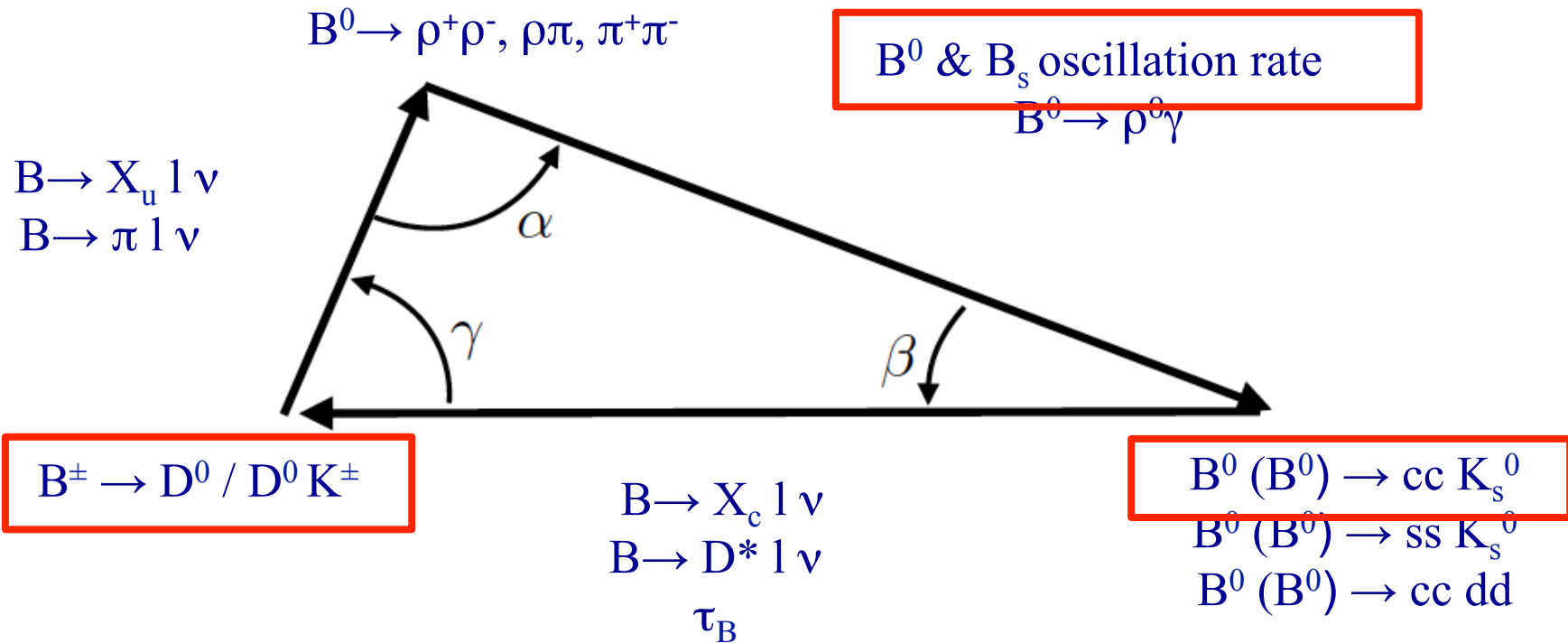

1st CKM measurement: $\sin 2\beta$

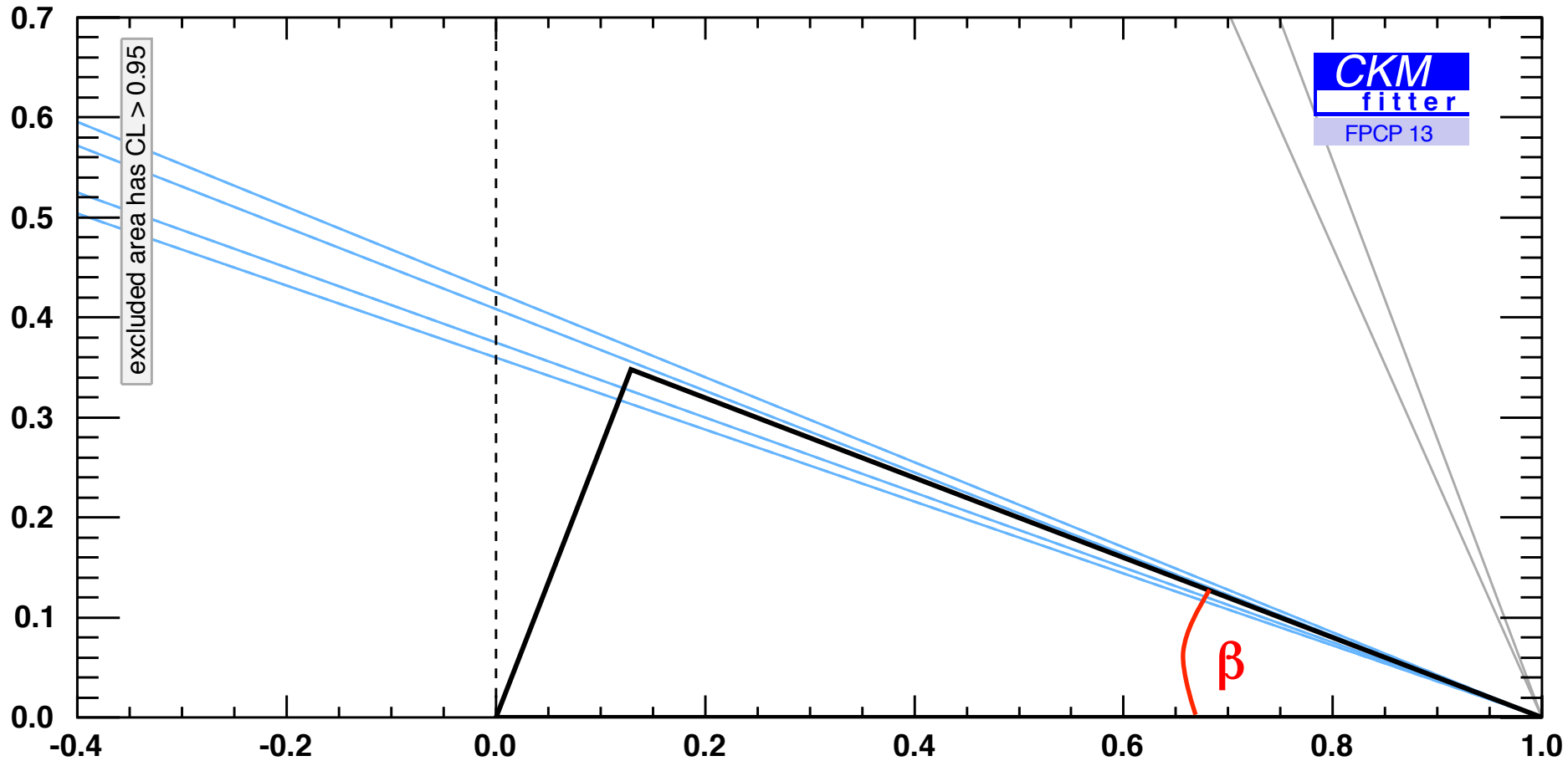

sin 2β: Golden decay $B^0 \rightarrow J/\psi K_s$

$$B^0 \rightarrow J/\psi K_s$$

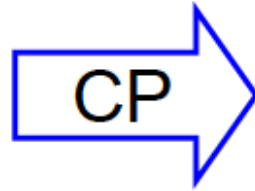

$$\bar{B}^0 \rightarrow J/\psi K_s$$

$$\eta_{CP} = -1$$

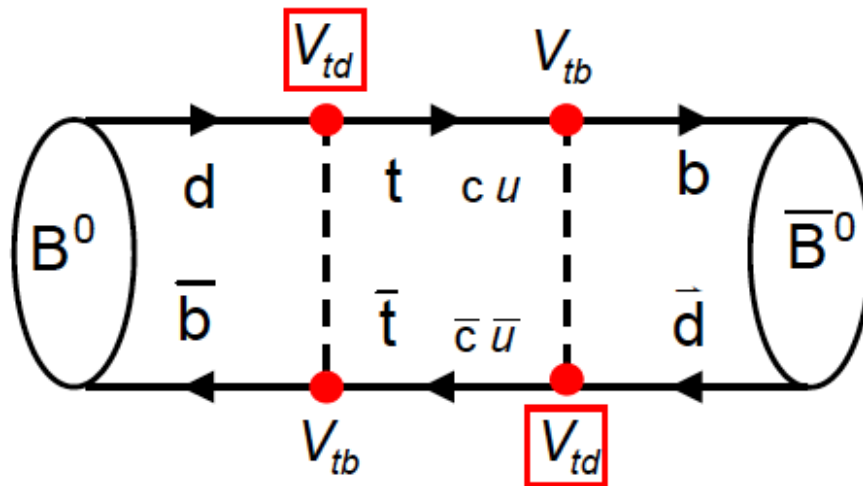
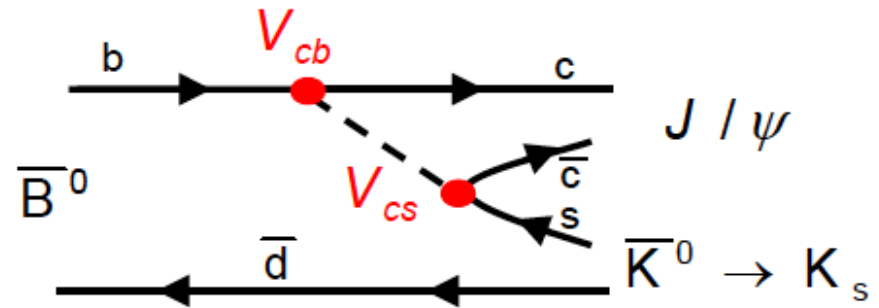
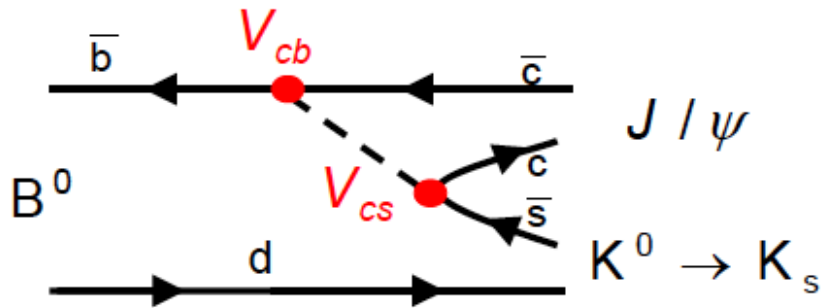

Mixing Phase:

$$e^{i\phi_d} = e^{i2\beta}$$

sin 2β: Golden decay $B^0 \rightarrow J/\psi K_S$

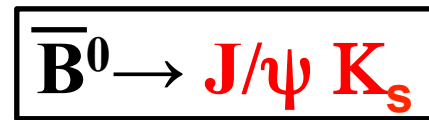
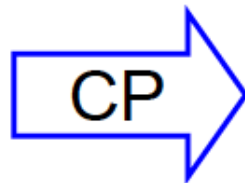
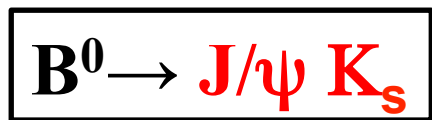

$$\eta_{CP} = -1$$

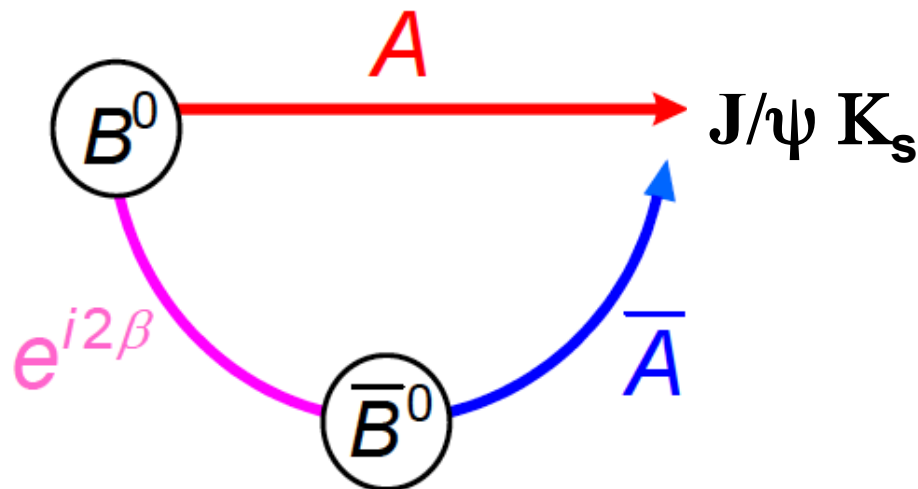

$$\Gamma(B^0 \rightarrow J/\psi K_S)(t) \neq \Gamma(\bar{B}^0 \rightarrow J/\psi K_S)(t)$$

$$\mathcal{A}_{CP} = \frac{\Gamma(\bar{B}^0 \rightarrow J/\psi K_S) - \Gamma(B^0 \rightarrow J/\psi K_S)}{\Gamma(\bar{B}^0 \rightarrow J/\psi K_S) + \Gamma(B^0 \rightarrow J/\psi K_S)} = \sin(2\beta) \sin(\Delta m t)$$

→ Requires knowledge of production flavour of the B

- Time evolution of $\Upsilon(4s)$ decay

- $t=0$: Decay of $\Upsilon(4s)$ into 2 B mesons

Neither B is in a specific eigenstate, but $B_1 B_2$ system evolves coherently, i.e. flavor anti-correlation preserved during evolution

- $t=t_{\text{tag}}$ One of the two mesons (B_1) decays.

If it decays into a flavor eigenstate, flavor conservation in the coherent $B_1 B_2$ system requires that also B_2 goes into a flavor eigenstate, even though it has not decayed yet!

- $t=t_{\text{CP}}$ The other B meson decays

mixing took place between t_{CP} and t_{tag} .

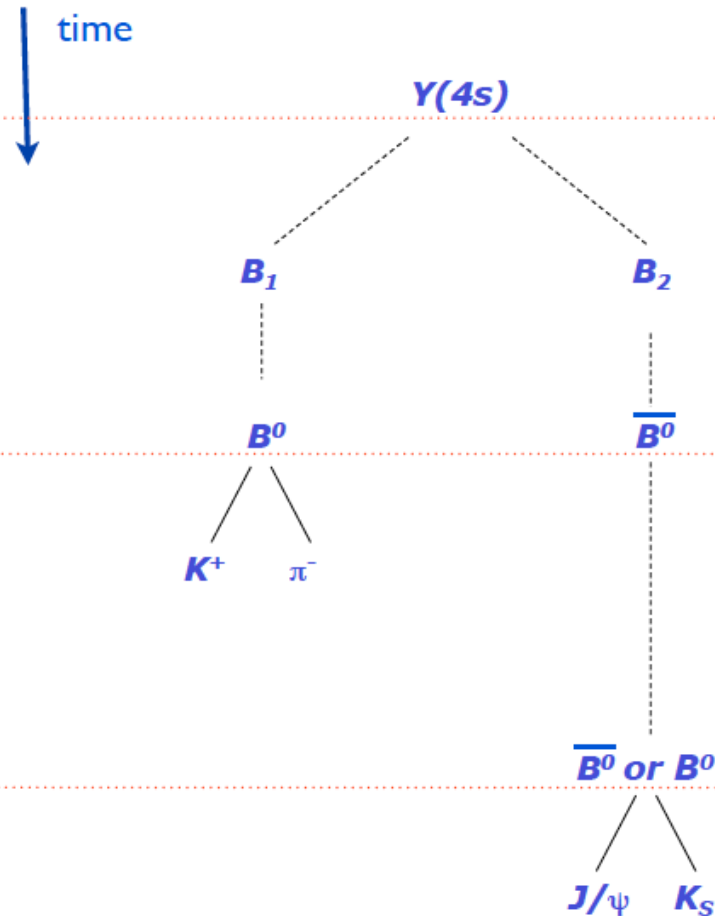

Tagging efficiency	Mistag probability	Dilution
$\varepsilon = \frac{\# \text{ tagged candidates}}{\# \text{ all candidates}}$	$\omega = \frac{\# \text{ tagged wrong}}{\# \text{ tagged}}$	$D = (1 - 2\omega)$

- Time evolution of $\Upsilon(4s)$ decay

- $t=0$: Decay of $\Upsilon(4s)$ into 2 B mesons

Neither B is in a specific eigenstate, but $B_1 B_2$ system evolves *coherently*, i.e. flavor *anti*-correlation preserved during evolution

- $t=t_{\text{tag}}$ One of the two mesons (B_1) decays

If it decays into a flavor eigenstate, flavor conservation in the coherent $B_1 B_2$ system requires that also B_2 goes into a flavor eigenstate, even though it has not decayed yet!

- $t=t_{\text{CP}}$ The other B meson decays

mixing took place between t_{CP} and t_{tag} .

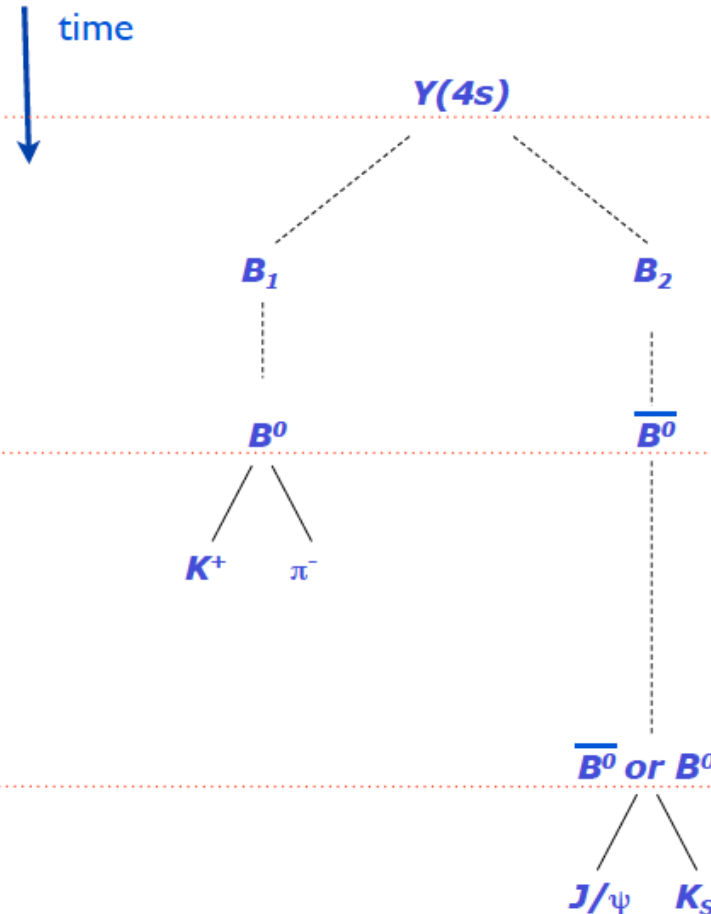

Effective tagging power: $\epsilon D^2 \sim 30\%$ (at B-factories)



How to extract $\sin 2\beta$

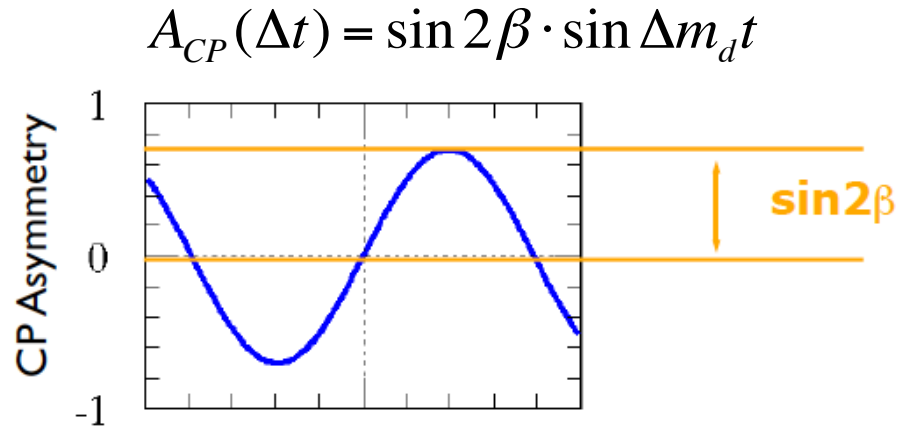
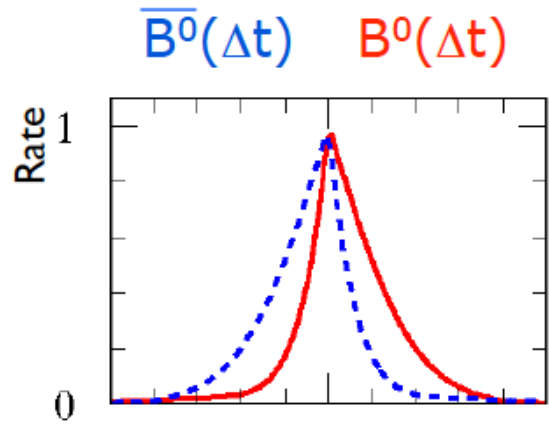

How to extract $\sin 2\beta$

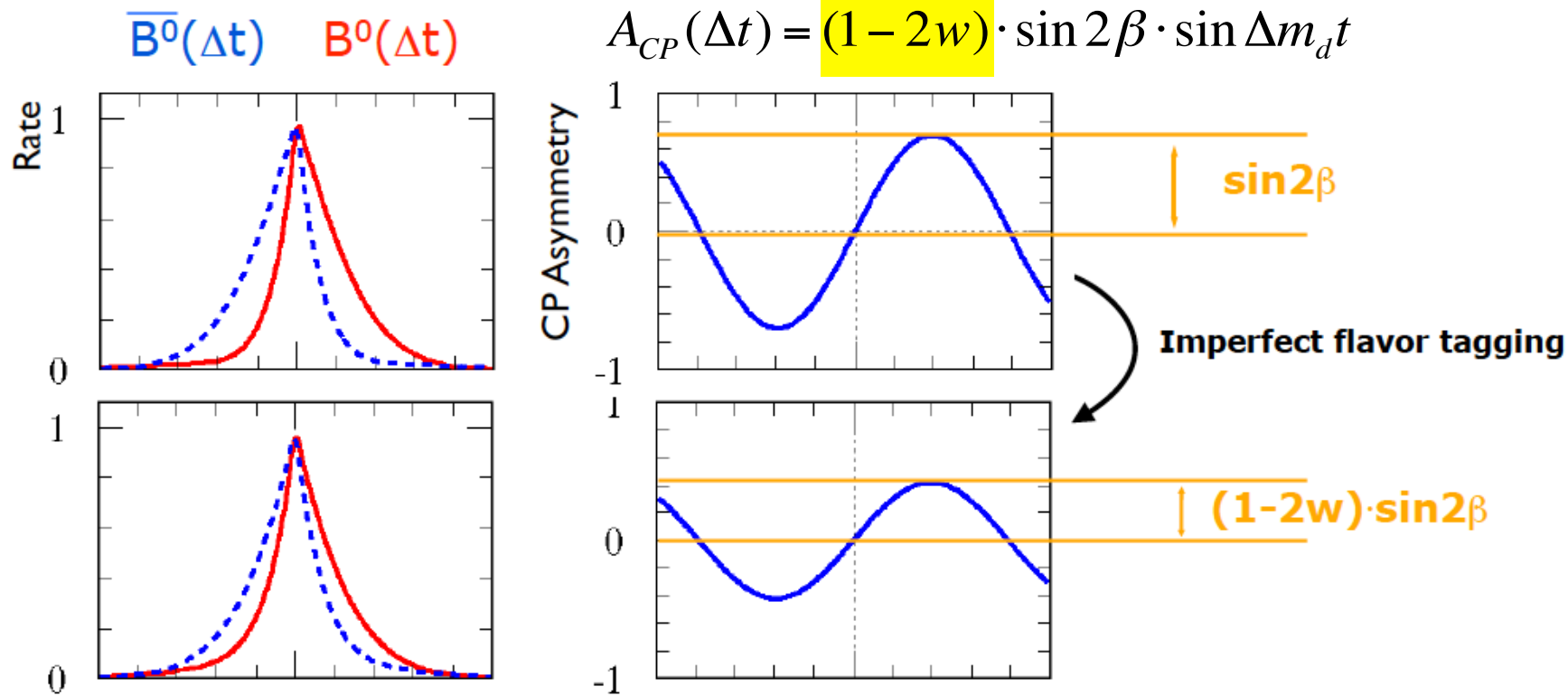

How to extract $\sin 2\beta$

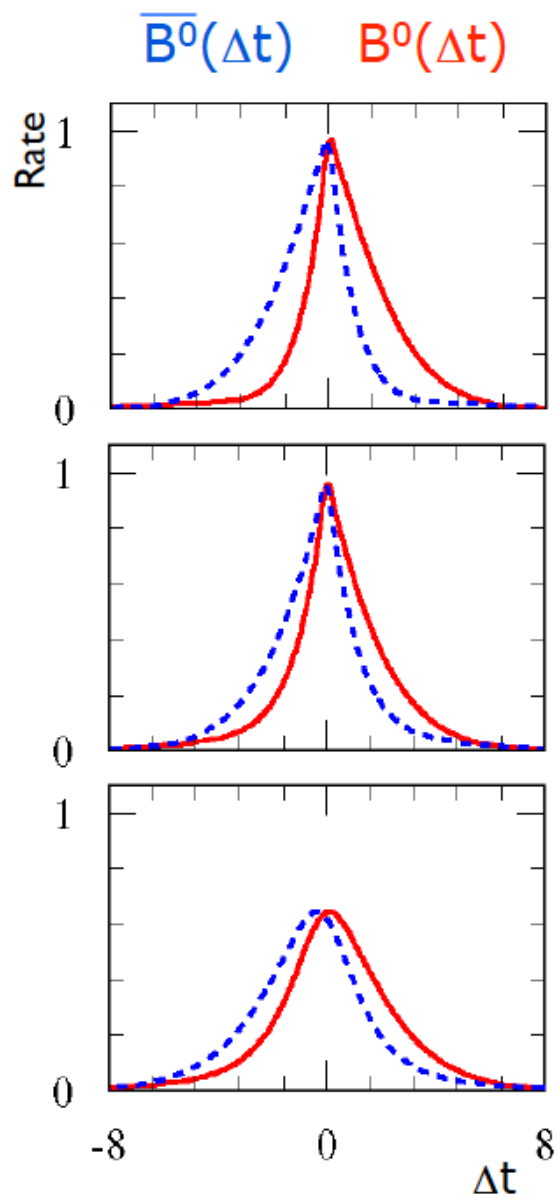

$$A_{CP}(\Delta t) = (1 - 2w) \cdot \sin 2\beta \cdot \sin \Delta m_d t$$

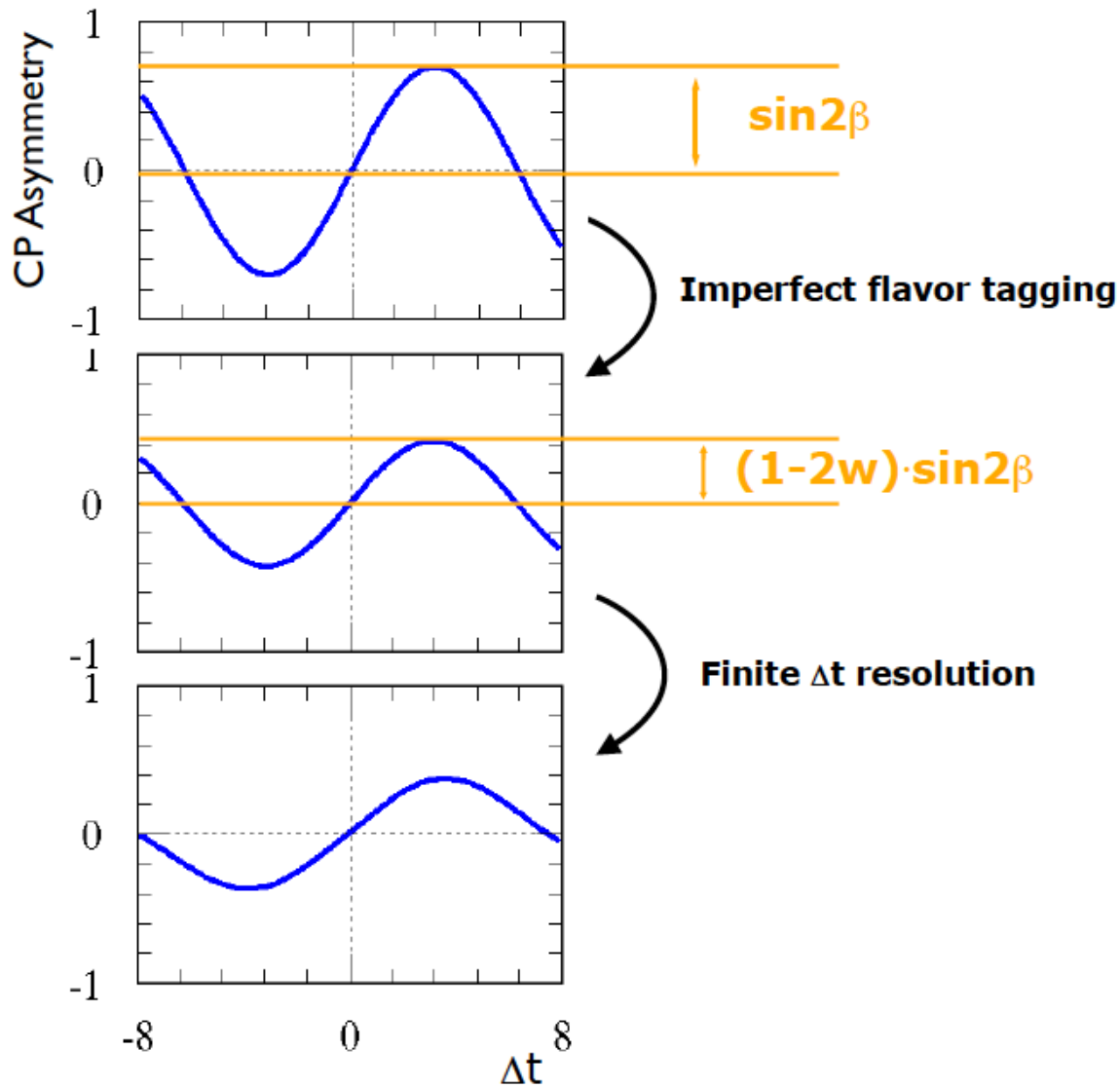

$$e^+e^- \rightarrow \Upsilon(4S) \rightarrow B_{\text{rec}}B_{\text{tag}} \quad \begin{array}{l} B_{\text{rec}} \rightarrow J/\psi K_S \\ B_{\text{tag}} \rightarrow \ell^\pm X, K^\pm X, \pi_{\text{soft}}^\mp, \pi_{\text{fast}}^\pm X, \dots \end{array}$$

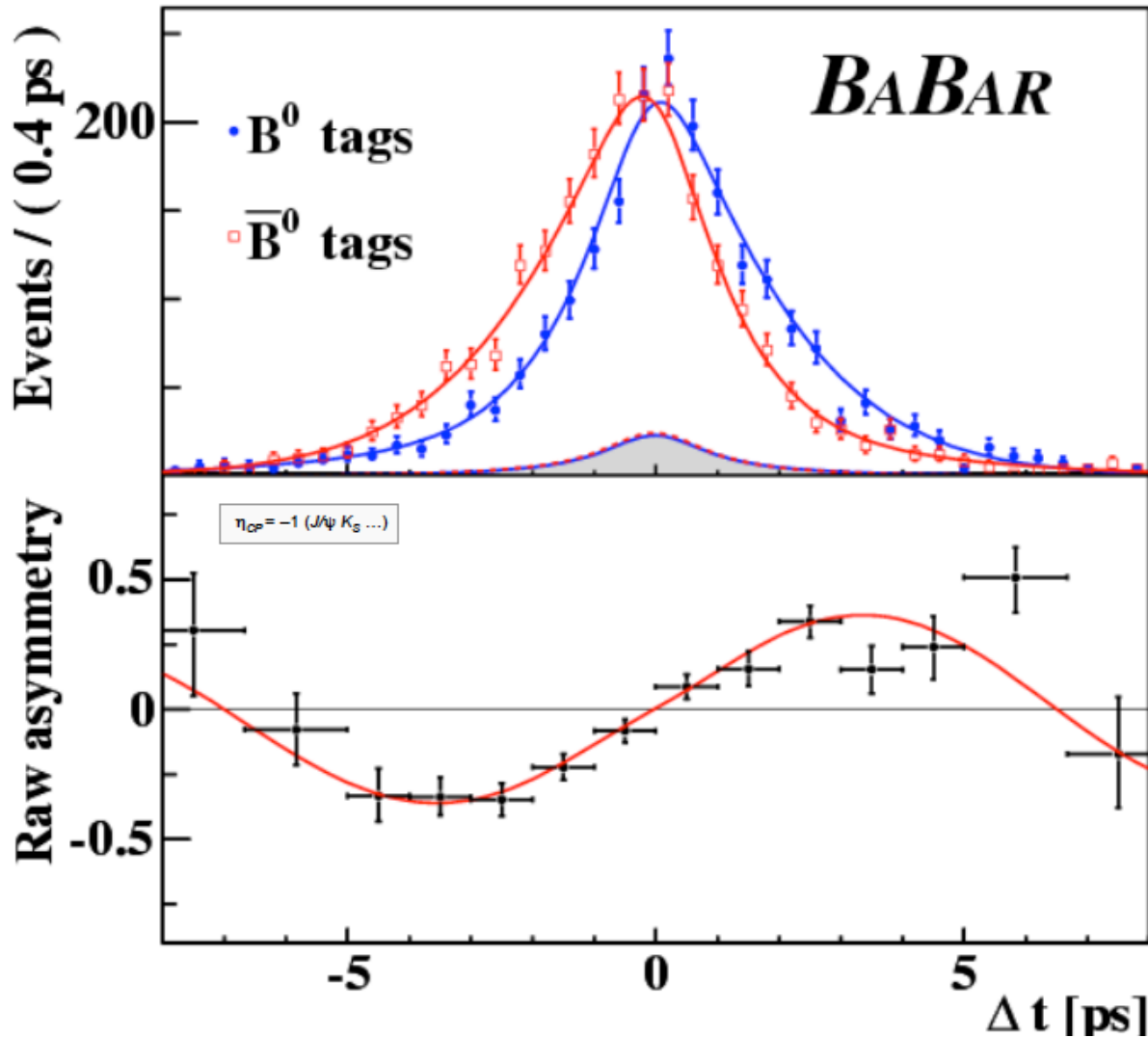

$\sin(2\beta) \equiv \sin(2\phi_1)$ **HFAG**
CKM 2012
PRELIMINARY

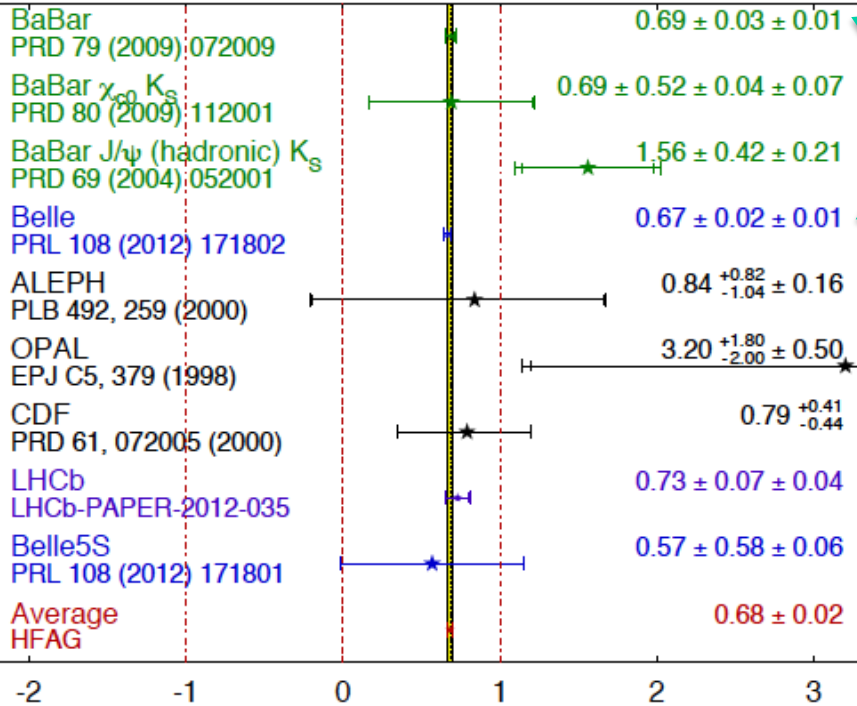

$B^0 \rightarrow cc K^{(*)0}$

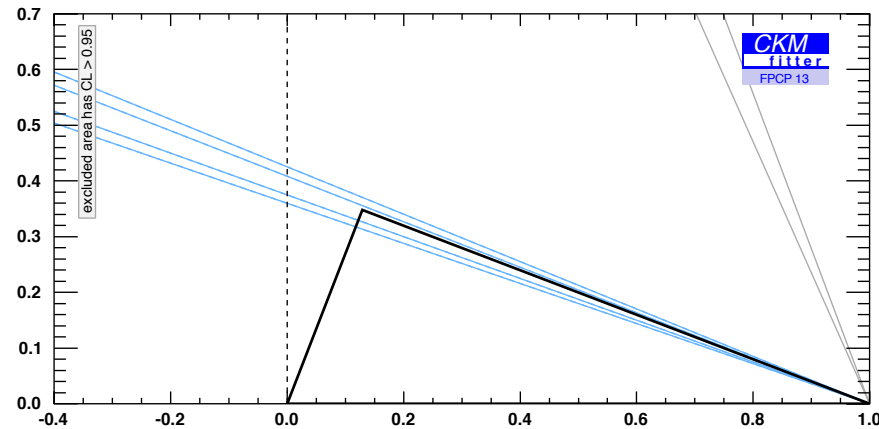
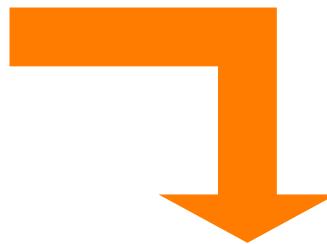

2nd CKM measurement: γ

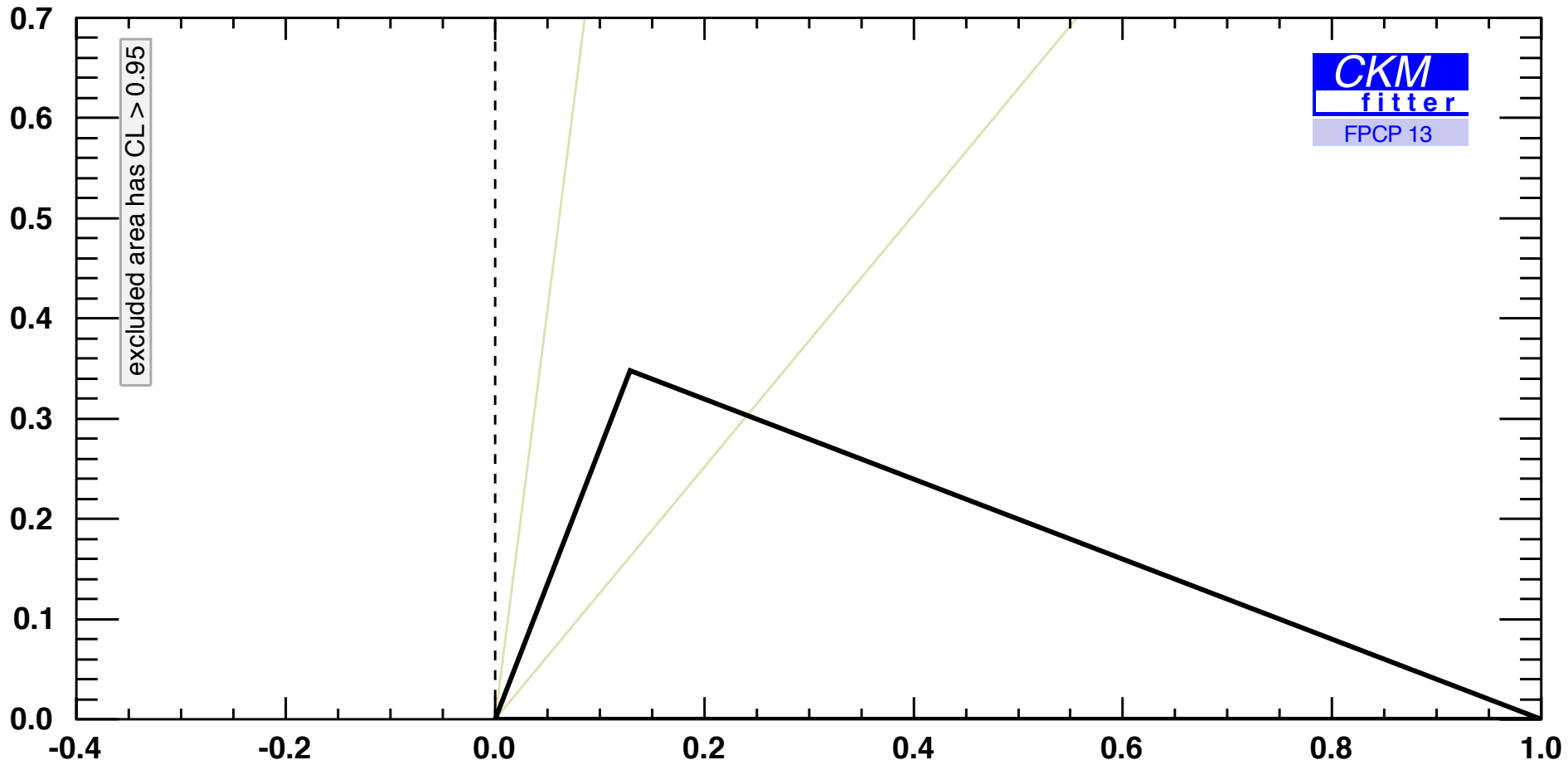

- The CKM angle γ plays a unique role in flavour physics
 - CP violating parameter that can be measured through tree decays
- A benchmark Standard Model reference point
 - Doubly important in case NP is observed

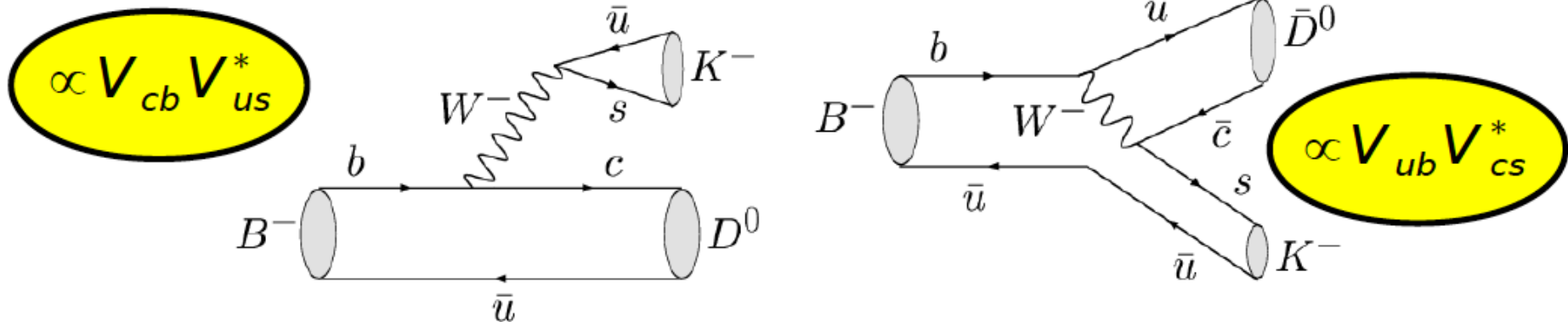

Variants use different B or D decays
 → require final state common to D^0 and \bar{D}^0

$$\propto V_{cb} V_{us}^*$$

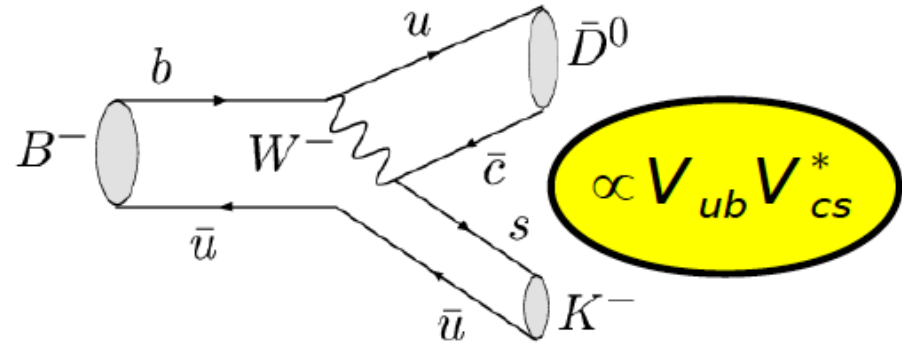
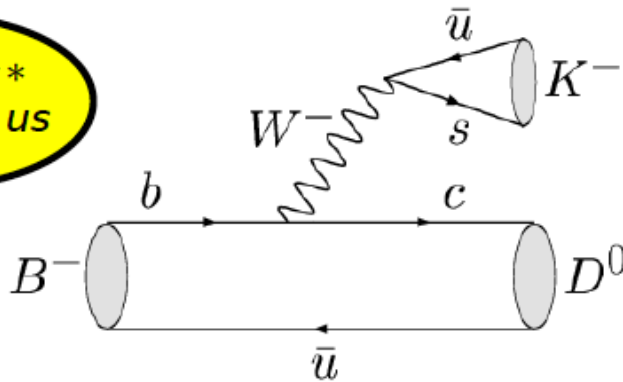

$$\propto V_{ub} V_{cs}^*$$

- Theoretical side:
 - Dominant, single tree diagram (suppression of loops)
 - All parameters can be determined from data

- Experimental side:
 - Many different final states \rightarrow different observables
 - All parameters can be determined from data
 - CKM angle γ
 - δ_B : weak & strong phase differences
 - r_B : ratio of amplitudes



Latest Measurements on $B \rightarrow D K$

PLB 712 (2012) 203

Evidence for direct CP violation ($\gamma \neq 0$)

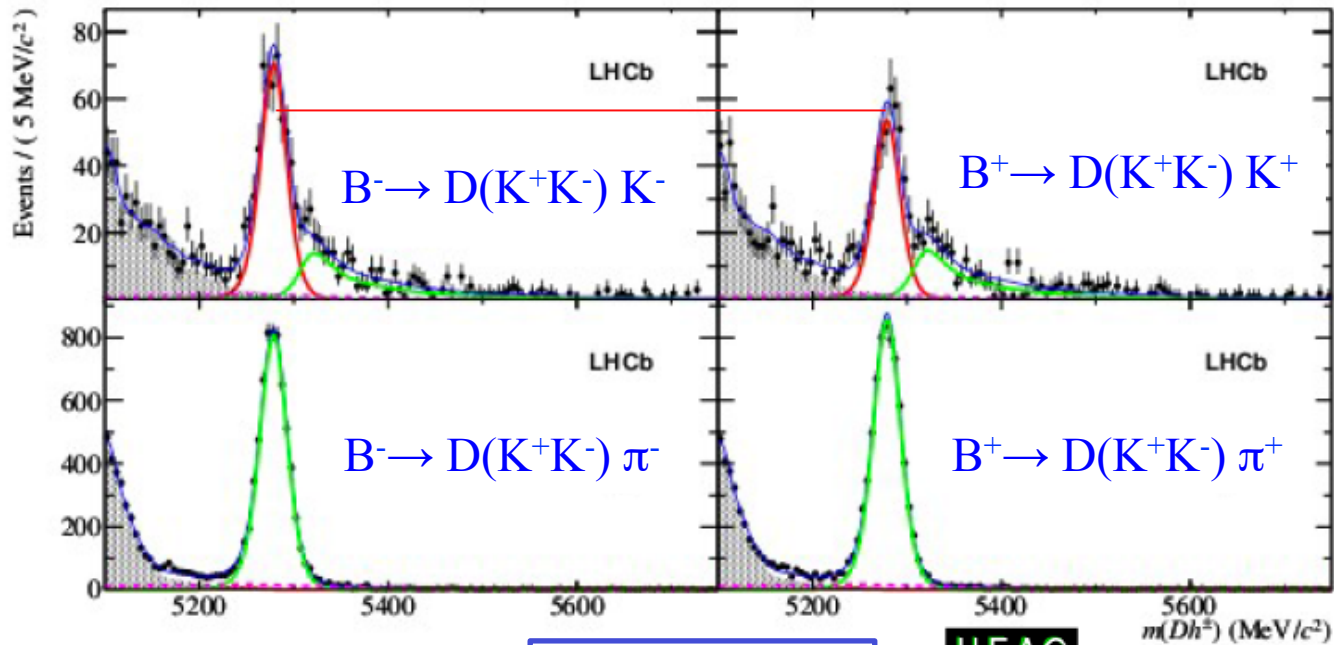

average

HFAG
Moriond 2012
PRELIMINARY

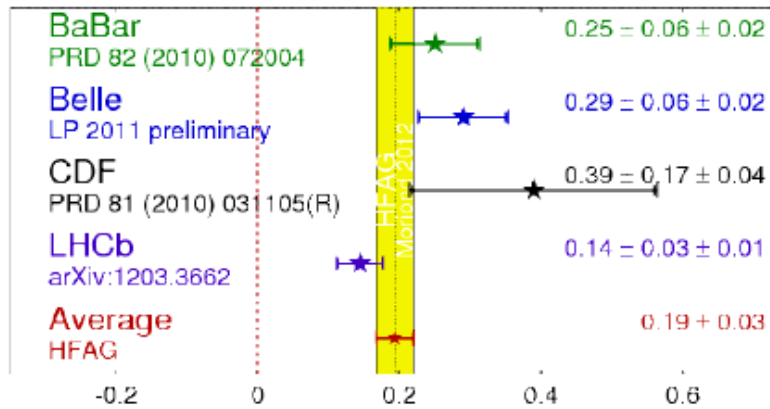

- Several different modes with each limited sensitivity on γ

Analysis	N_{obs}	Parameters
$B^+ \rightarrow Dh^+, D \rightarrow hh, \text{GLW/ADS}$	13	$\gamma, r_B, \delta_B, r_B^\pi, \delta_B^\pi, R_{K/\pi}, r_{K\pi}, \delta_{K\pi}, A_{CP}^{D \rightarrow KK}, A_{CP}^{D \rightarrow \pi\pi}$
$B^+ \rightarrow DK^+, D \rightarrow K_s^0 h^+ h^-, \text{GGSZ}$	4	γ, r_B, δ_B
$B^+ \rightarrow Dh^+, D \rightarrow K\pi\pi\pi, \text{ADS}$	7	$\gamma, r_B, \delta_B, r_B^\pi, \delta_B^\pi, R_{K/\pi}, r_{K3\pi}, \delta_{K3\pi}, \kappa_{K3\pi}$
CLEO $D^0 \rightarrow K\pi, D^0 \rightarrow K\pi\pi\pi$	9	$x_D, y_D, \delta_{K\pi}, \delta_{K3\pi}, \kappa_{K3\pi}, r_{K\pi}, r_{K3\pi}, \mathcal{B}(K\pi), \mathcal{B}(K\pi\pi\pi)$
CP violation in the charm system	2	$A_{CP}^{D \rightarrow KK}, A_{CP}^{D \rightarrow \pi\pi}$
charm mixing	3	$x_D, y_D, \delta_{K\pi}, r_{K\pi}$

LHCb measurements sensitive to γ

External inputs

- Combine them using a frequentist approach

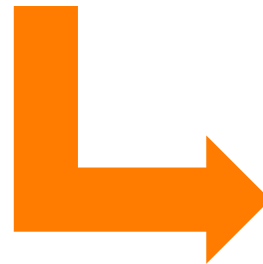

γ from $B \rightarrow DK$ ADS(1 fb⁻¹)/GLW(1 fb⁻¹)/GGSZ(3 fb⁻¹) combined:
 $\gamma = (67 \pm 12)^\circ$

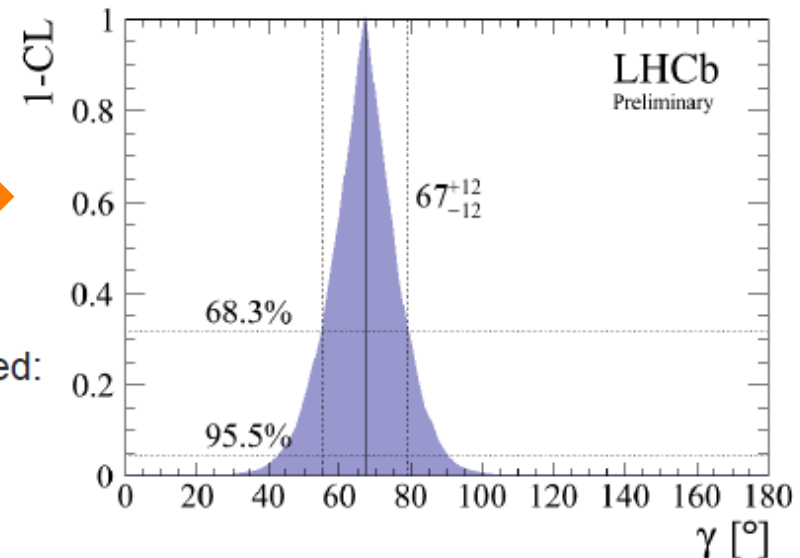

- Sensitivity: BaBar & Belle each $\sim 16^\circ$; latest LHCb $\sim 12^\circ$

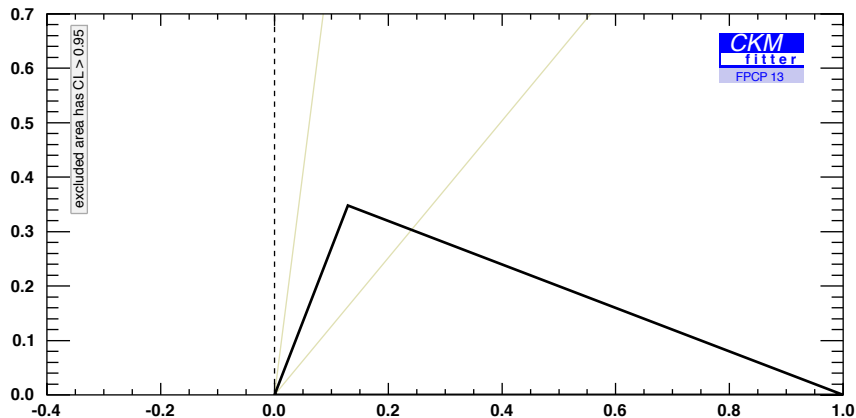
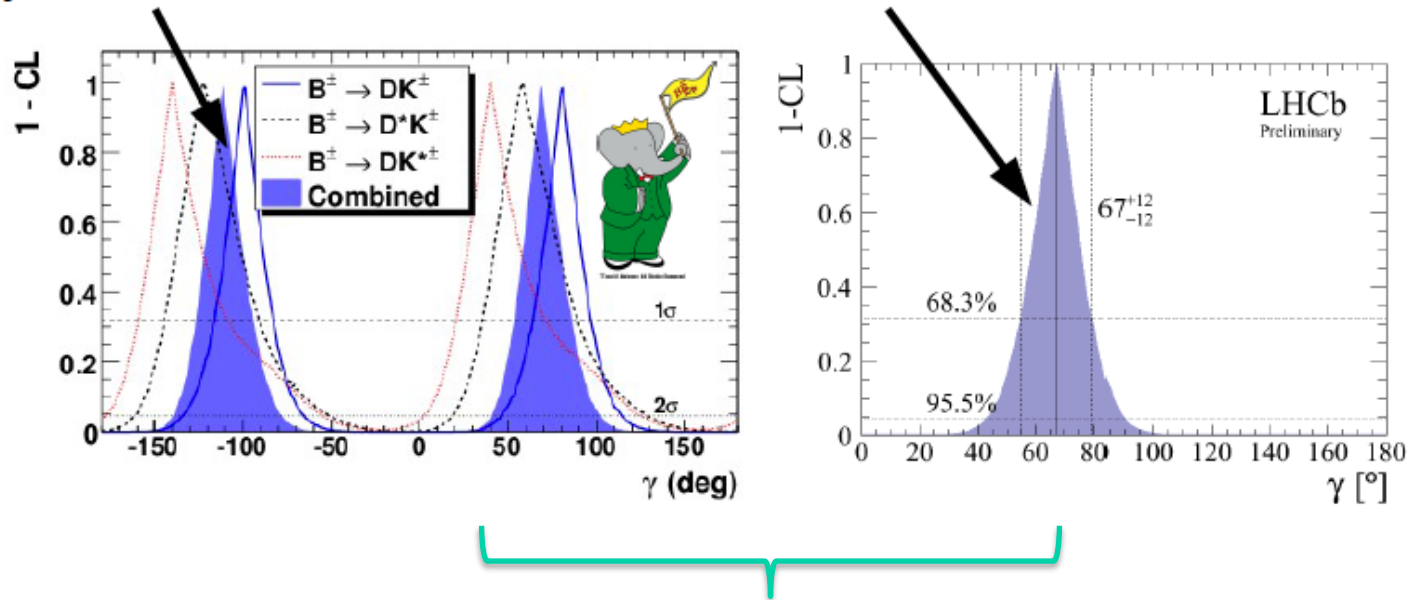

$\sin 2\beta$

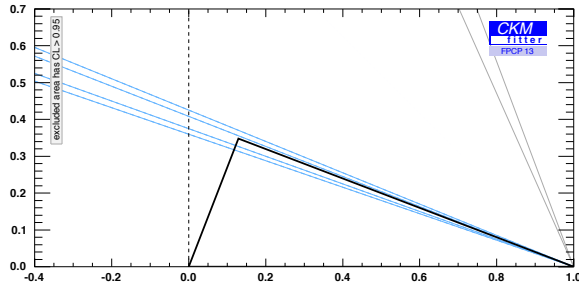

γ

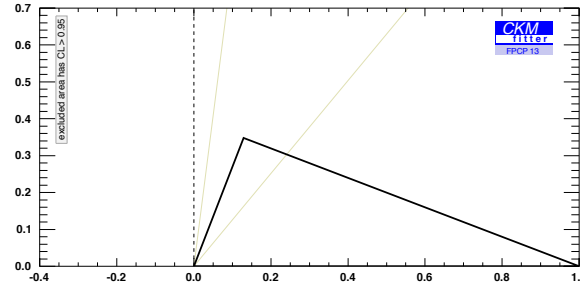

Bs and Bd mixing

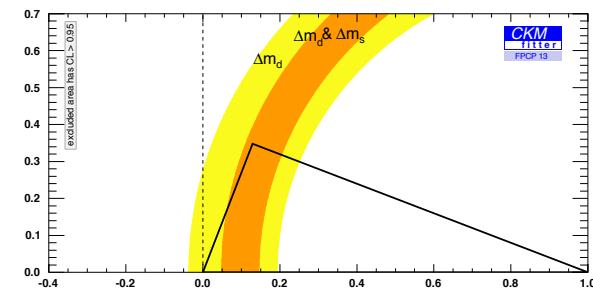

Adding many
complimentary
measurements

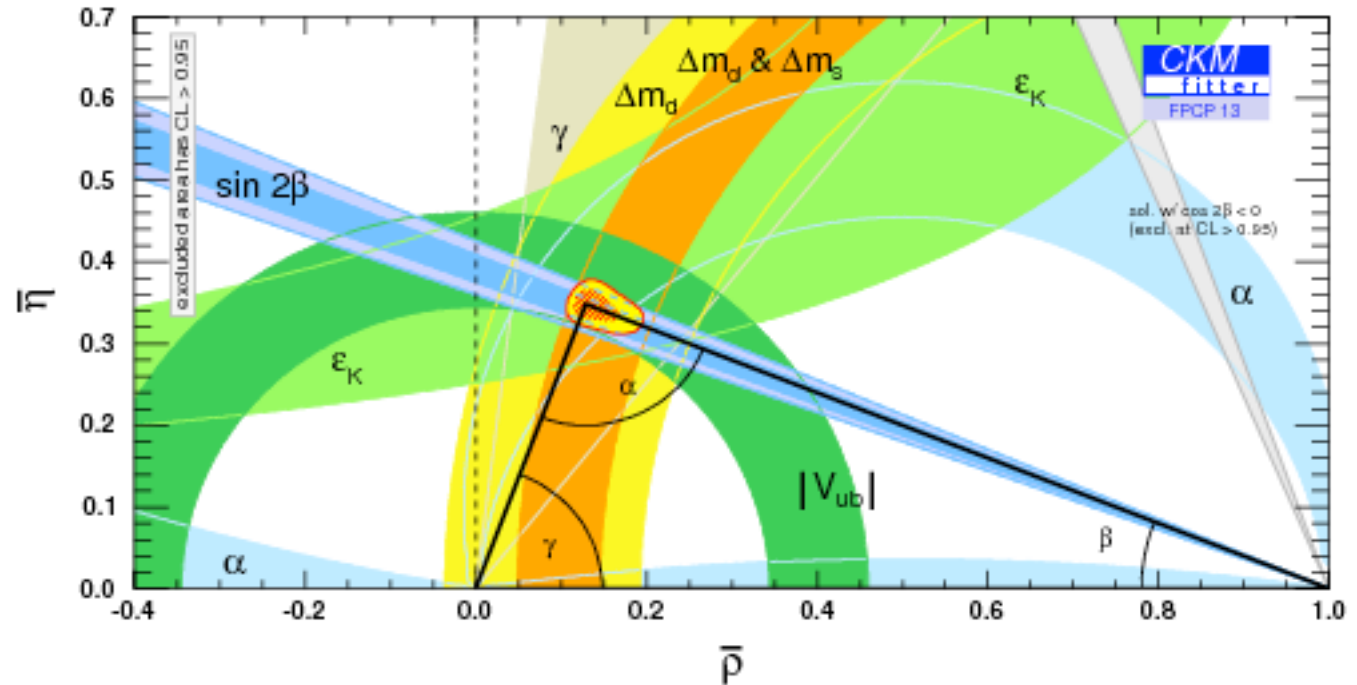

- Tree Processes only

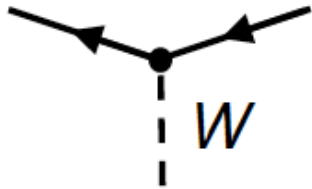

SM dominant
 → no new effects
 expected

- Loop processes only

New Physics is
 expected to appear
 in loops

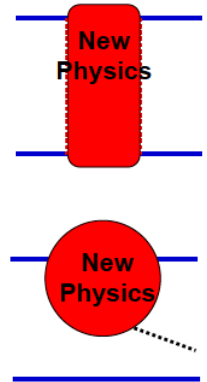

- Tree Processes only

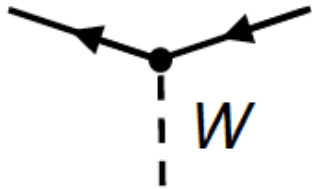

SM dominant
 → no new effects
 expected

$$|V_{ub}/V_{cb}|, B \rightarrow \tau\nu, \gamma, \pi - \alpha - \beta$$

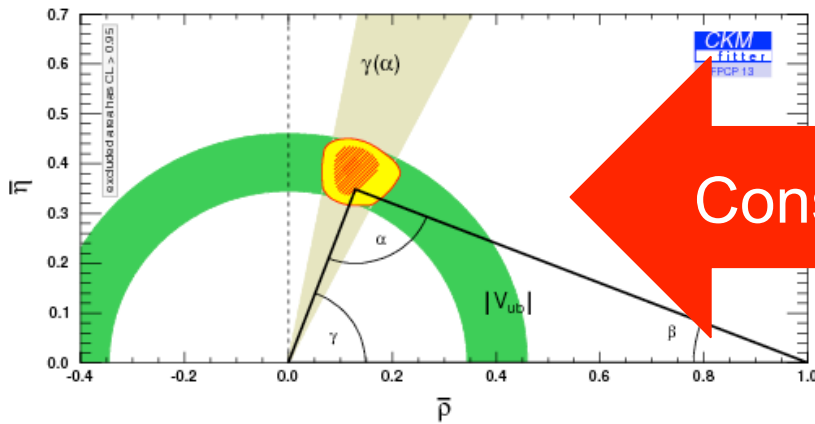

- Loop processes only

New Physics is
 expected to appear
 in loops

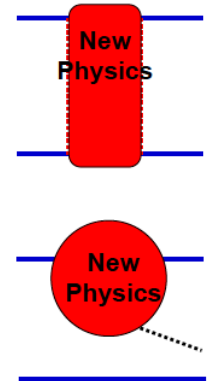

$$|\epsilon_K|, \sin 2\beta, \Delta m_d, \Delta m_s$$

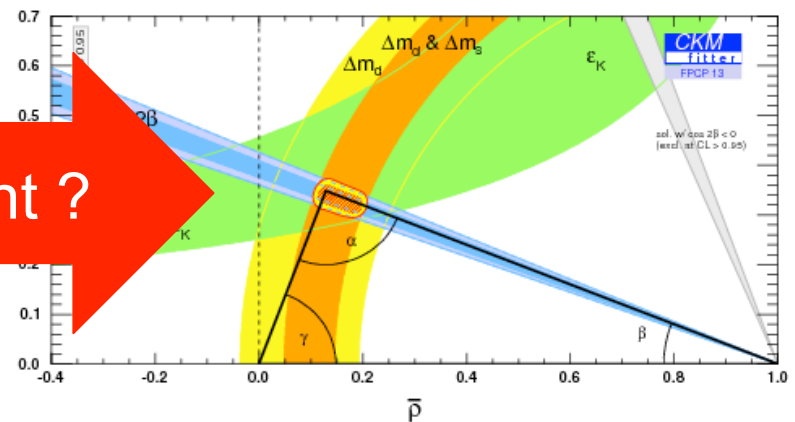

Consistent ?

Apex known with 10-20%, aim at <1%



3rd CKM measurement: $B_{s,d}$ mixing frequency

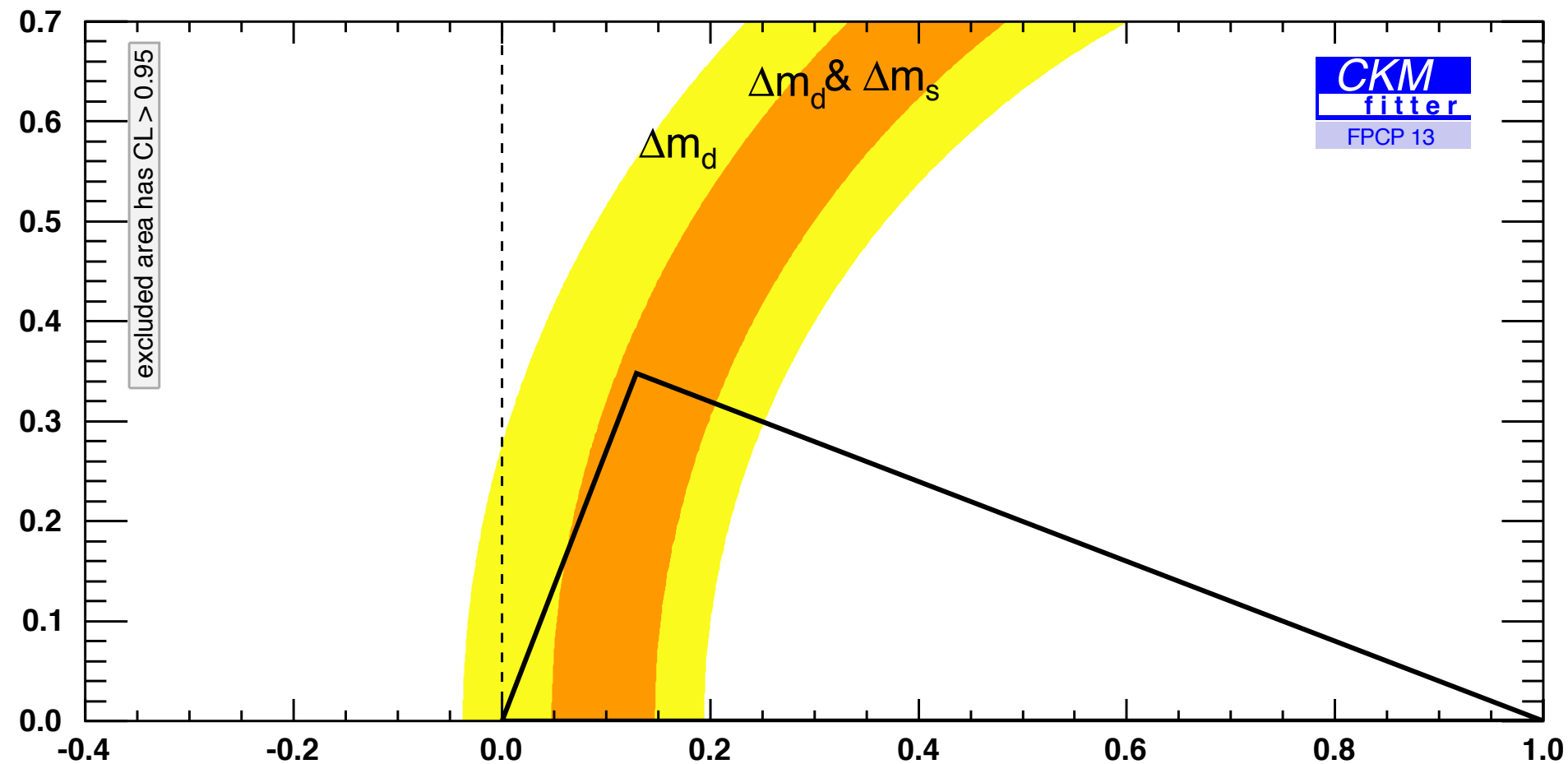

Phenomenological Schroedinger equation describing oscillation and decay

$$i \frac{d}{dt} \begin{pmatrix} B_s^0 \\ \bar{B}_s^0 \end{pmatrix} = \left(M - \frac{i}{2} \Gamma \right) \begin{pmatrix} B_s^0 \\ \bar{B}_s^0 \end{pmatrix} \quad M = \begin{pmatrix} M_{11} & M_{12} \\ M_{12}^* & M_{22} \end{pmatrix}; \Gamma = \begin{pmatrix} \Gamma_{11} & \Gamma_{12} \\ \Gamma_{12}^* & \Gamma_{22} \end{pmatrix}$$

Mass eigenstates \neq flavour eigenstates \rightarrow mass difference \propto osc. frequency

$$|B_L\rangle = p|B_s^0\rangle + q|\bar{B}_s^0\rangle$$

$$|B_H\rangle = p|B_s^0\rangle - q|\bar{B}_s^0\rangle$$

$$\Delta m_s = m_H - m_L = 2|M_{12}|$$

$$\Delta\Gamma_s = \Gamma_L - \Gamma_H$$

$$\phi_M = \arg(M_{12})$$

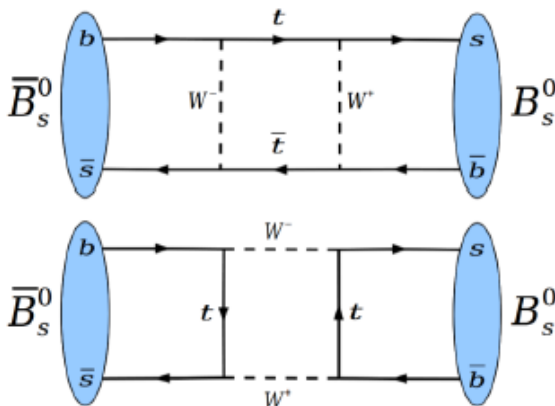

Dominant Feynman diagrams
(Standard Model)

Δm_s from $B_s \rightarrow D_s \pi^+$

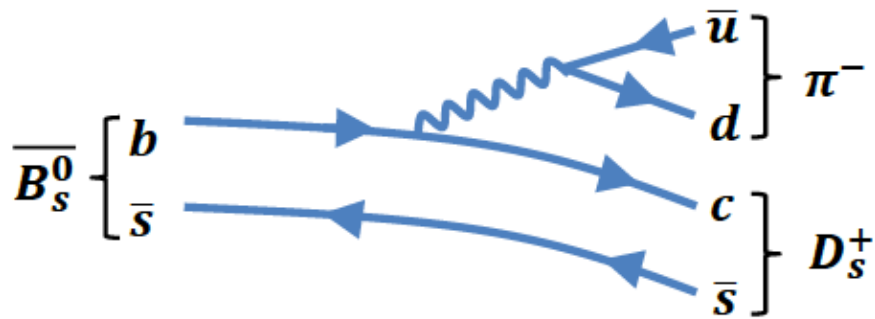

New J. Phys. 15 (2013) 053021

- Very high statistics
- Low background level
- Can resolve B_s mixing frequency due to high boost

Use flavour tagging to determine flavour at production, pion charge for flavour at decay

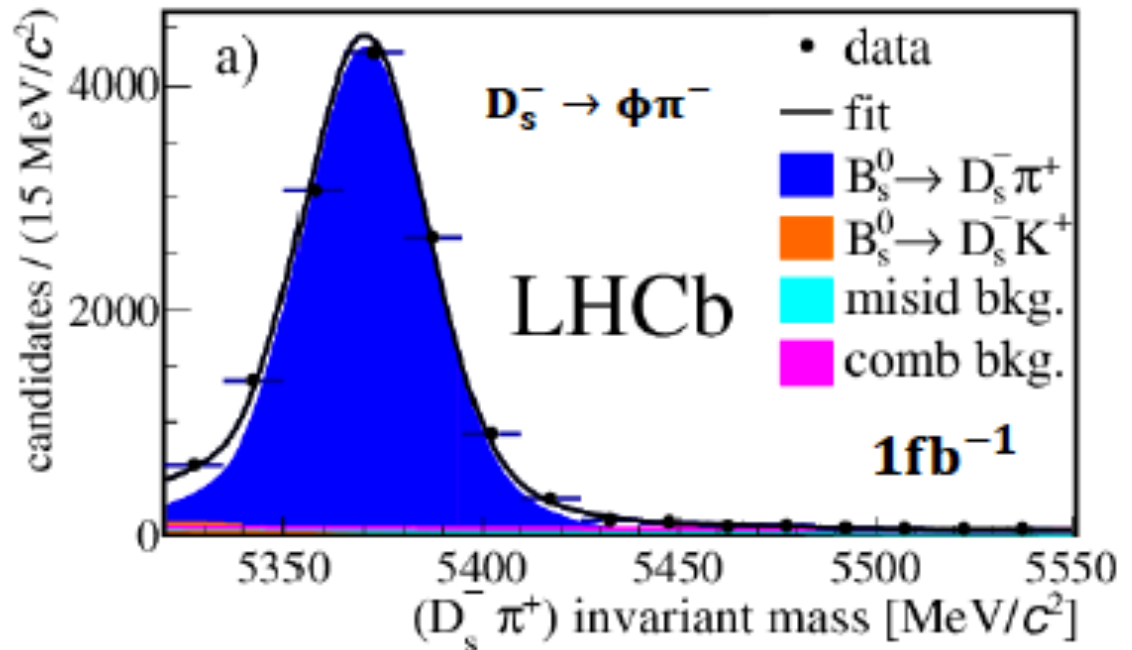

Tagging efficiency

$$\varepsilon = \frac{\# \text{ tagged candidates}}{\# \text{ all candidates}}$$

Mistag probability

$$\omega = \frac{\# \text{ tagged wrong}}{\# \text{ tagged}}$$

Dilution

$$D = (1 - 2\omega)$$

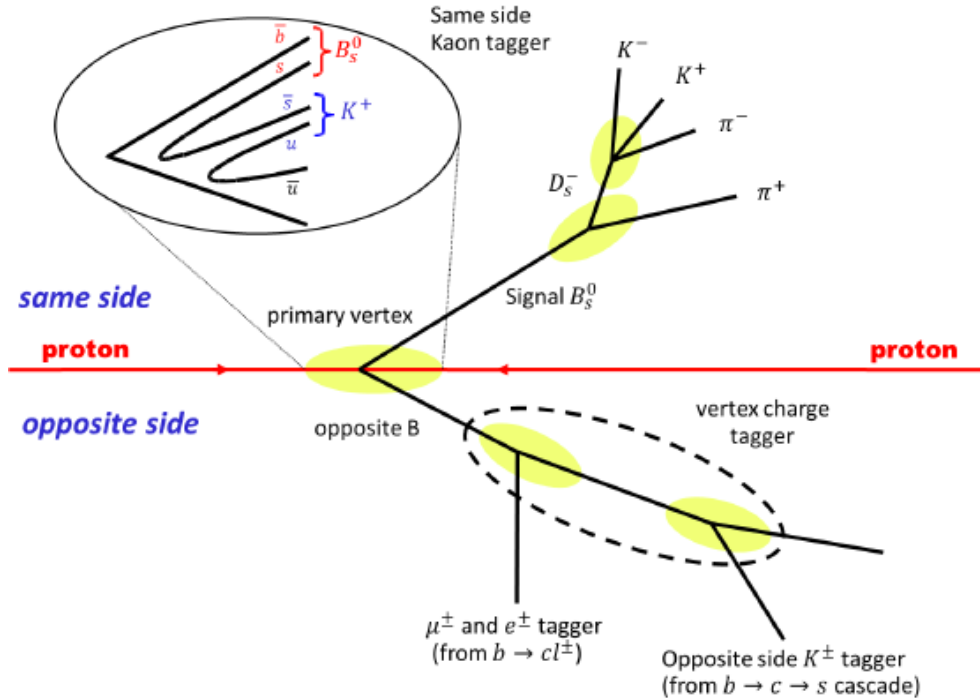

- Opposite side taggers
 - exploits $b\bar{b}$ pair production by partially reconstructing the second B-hadron in the event
- Same side kaon tagger
 - exploits hadronization of signal B_S -meson
- Combined tagging power (in $B_S^0 \rightarrow D_S^- \pi^+$)
 - $\varepsilon D^2 = 3.5 \pm 0.5\%$

Tagging efficiency

$$\varepsilon = \frac{\# \text{ tagged candidates}}{\# \text{ all candidates}}$$

Mistag probability

$$\omega = \frac{\# \text{ tagged wrong}}{\# \text{ tagged}}$$

Dilution

$$D = (1 - 2\omega)$$

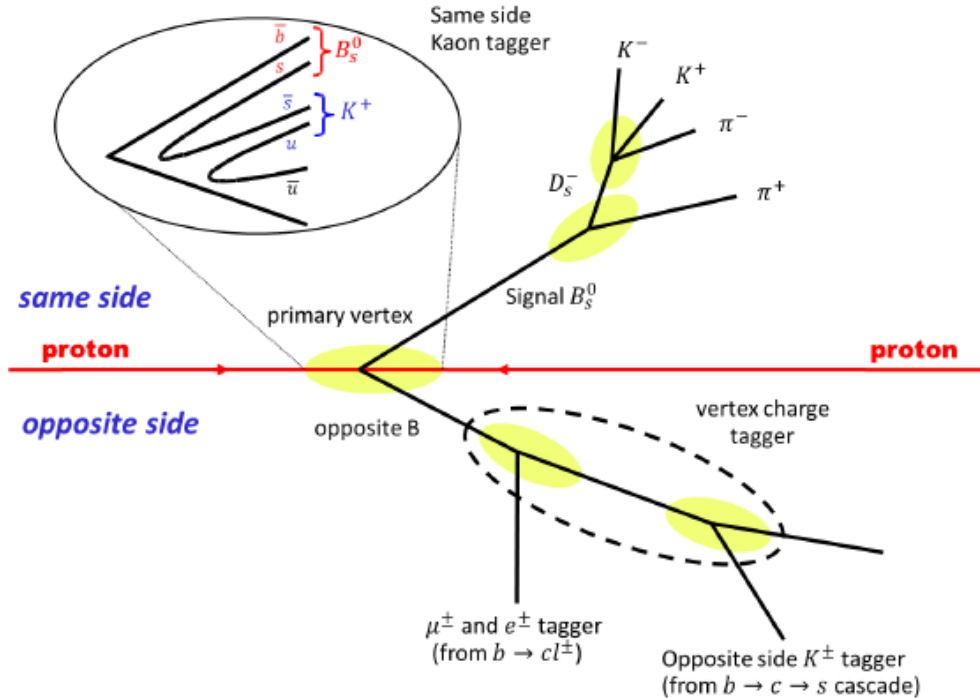

- Opposite side taggers
 - exploits $b\bar{b}$ pair production by partially reconstructing the second B-hadron in the event
- Same side kaon tagger
 - exploits hadronization of signal B_s -meson
- Combined tagging power (in $B_s^0 \rightarrow D_s^- \pi^+$)
 - $\varepsilon D^2 = 3.5 \pm 0.5\%$

Compare this to e^+e^- colliders:
 $\varepsilon D^2 \sim 30\%$

Δm_s from $B_s \rightarrow D_s \pi^+$

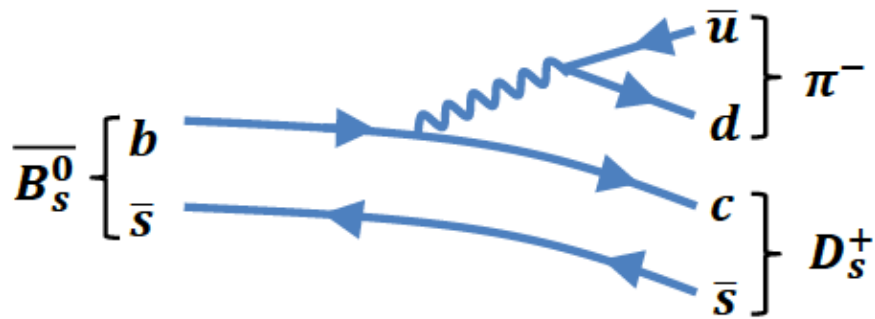

New J. Phys. 15 (2013) 053021

- Very high statistics
- Low background level
- Can resolve B_s mixing frequency due to high boost

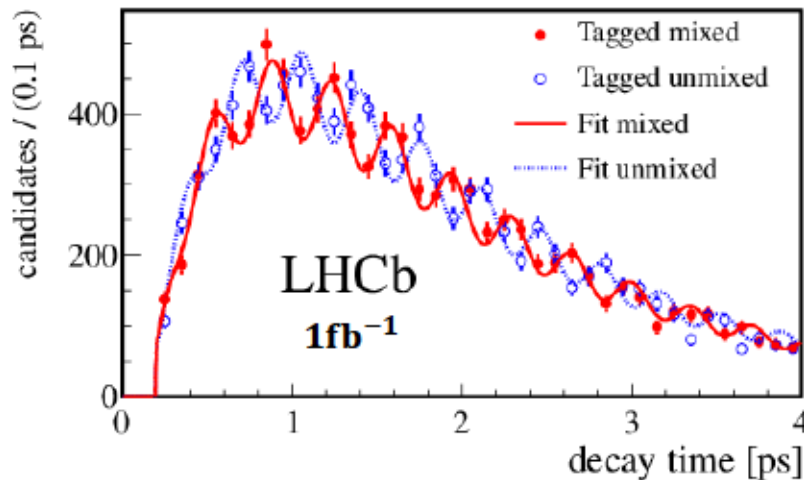

Uses flavour tagging:
 opposite side (*Eur.Phys.J. C72(2012) 2022*)
 same side (LHCb-CONF-2012-033)

$$\Delta m_s = 17.768 \pm 0.023(stat) \pm 0.006(syst) ps^{-1}$$

Slide shown by D. Straub, flavour theory lecture I

Our final result reads

$$A(B^0 \rightarrow \bar{B}^0) = \frac{G_F^2}{6\pi^2} m_W^2 m_B (V_{tb}^* V_{td})^2 S_0(x_t) \hat{\eta}_B f_B^2 \hat{B}$$

and we needed

- ▶ CKM elements,
- ▶ short-distance contributions (box diagram!),
- ▶ QCD corrections, and
- ▶ input from the lattice.